



---

# ***Operators and Safety Manual***

**Model**  
**1932E2**  
**2032E2**  
**2632E2**  
**2646E2**  
**3246E2**

**3120854**

June 25, 2004

***ANSI***





## **FOREWORD**

This manual is a very important tool! Keep it with the machine at all times.

The purpose of this manual is to provide owners, users, operators, lessors, and lessees with the precautions and operating procedures essential for the safe and proper machine operation for its intended purpose.

Due to continuous product improvements, JLG Industries, Inc. reserves the right to make specification changes without prior notification. Contact JLG Industries, Inc. for updated information.

## **SAFETY ALERT SYMBOLS AND SAFETY SIGNAL WORDS**



This is the Safety Alert Symbol. It is used to alert you to the potential personal injury hazards. Obey all safety messages that follow this symbol to avoid possible injury or death

### **⚠ DANGER**

INDICATES AN IMMINENTLY HAZARDOUS SITUATION WHICH, IF NOT AVOIDED, WILL RESULT IN SERIOUS INJURY OR DEATH. ON THE MACHINE THIS WILL HAVE A RED BACKGROUND.

### **⚠ WARNING**

INDICATES A POTENTIALITY HAZARDOUS SITUATION WHICH, IF NOT AVOIDED, COULD RESULT IN SERIOUS INJURY OR DEATH. ON THE MACHINE THIS WILL HAVE AN ORANGE BACKGROUND.

### **⚠ CAUTION**

INDICATES A POTENTIALITY HAZARDOUS SITUATION WHICH IF NOT AVOIDED, MAY RESULT IN MINOR OR MODERATE INJURY. IT MAY ALSO BE USED TO ALERT AGAINST UNSAFE PRACTICES. ON THE MACHINE THIS WILL HAVE A YELLOW BACKGROUND.

### **IMPORTANT**

INDICATES PROCEDURES ESSENTIAL FOR SAFE OPERATION AND WHICH, IF NOT FOLLOWED, MAY RESULT IN A MACHINE MALFUNCTIONED DAMAGE. ON THE MACHINE THIS WILL HAVE A GREEN BACKGROUND.

**⚠ WARNING**

THIS PRODUCT MUST COMPLY WITH ALL SAFETY RELATED BULLETINS. CONTACT JLG INDUSTRIES, INC. OR THE LOCAL AUTHORIZED JLG REPRESENTATIVE FOR INFORMATION REGARDING SAFETY-RELATED BULLETINS WHICH MAY HAVE BEEN ISSUED FOR THIS PRODUCT.

MODIFICATION OR ALTERATION OF AN AERIAL WORK PLATFORM SHALL BE MADE ONLY WITH WRITTEN PERMISSION FROM THE MANUFACTURER

**IMPORTANT**

JLG INDUSTRIES, INC. SENDS SAFETY RELATED BULLETINS TO THE OWNER OF RECORD OF THIS MACHINE. CONTACT JLG INDUSTRIES, INC. TO ENSURE THAT THE CURRENT OWNER RECORDS ARE UPDATED AND ACCURATE.

**IMPORTANT**

JLG INDUSTRIES, INC. MUST BE NOTIFIED IMMEDIATELY IN ALL INSTANCES WHERE JLG PRODUCTS HAVE BEEN INVOLVED IN AN ACCIDENT INVOLVING BODILY INJURY OR DEATH OF PERSONNEL OR WHEN SUBSTANTIAL DAMAGE HAS OCCURRED TO PERSONAL

**FOR :**

- Accident Reporting
- Product Safety Publications
- Current Owner Updates
- Questions Regarding Product Safety
- Standards and Regulations Compliance Information
- Questions Regarding Special Product Applications
- Questions Regarding Product Modifications

**CONTACT :**

Product Safety and Reliability Department  
JLG Industries, Inc.  
1 JLG Drive  
McConnellsburg, PA 17233

In USA:

Toll Free: 877-JLG-SAFE  
877-554-7233

Outside USA:

717-485-5161

E-mail: ProductSafety@JLG.com

## **REVISION LOG**

Original Issue	- February, 1998
Revised	- May, 1998
Revised	- February, 1999
Revised	- November 2, 1999
Revised	- July 21, 2000
Revised	- November 16, 2001
Revised	- January 15, 2002
Revised	- June 16, 2003
Revised	- June 25, 2004

**TABLE OF CONTENTS**

<b>SUBJECT - SECTION, PARAGRAPH</b>	<b>PAGE NO.</b>
<b>SECTION - FOREWORD</b>	
<b>SECTION 1 - SAFETY PRECAUTIONS</b>	
1.1 General . . . . .	1-1
1.2 Pre-operation . . . . .	1-1
1.3 Operation . . . . .	1-2
1.4 Towing, Lifting, and Hauling . . . . .	1-4
1.5 Additional Hazards / Safety . . . . .	1-4
<b>SECTION 2 - USER RESPONSIBILITIES, MACHINE PREPARATION, AND INSPECTION</b>	
2.1 Personnel Training . . . . .	2-1
2.2 Preparation, Inspection, and Maintenance . . . . .	2-2
<b>SECTION 3 - USER RESPONSIBILITIES AND MACHINE CONTROL</b>	
3.1 General . . . . .	3-1
3.2 Personnel Training . . . . .	3-1
3.3 Operating Characteristics and Limitations . . . . .	3-1
3.4 Controls and Indicators for Non Proportional Control . . . . .	3-2
3.5 Controls and Indicators for Proportional Control . . . . .	3-5
<b>SECTION 4 - MACHINE OPERATION</b>	
4.1 Description . . . . .	4-1
4.2 General . . . . .	4-2
4.3 Motor Operation . . . . .	4-2
4.4 Raising and Lowering (Lifting) . . . . .	4-2
4.5 Platform Extension . . . . .	4-3
4.6 Steering . . . . .	4-3
4.7 Traveling (Driving) . . . . .	4-3
4.8 Parking and Stowing . . . . .	4-4
4.9 Platform Loading . . . . .	4-5
4.10 Safety Prop . . . . .	4-5
4.11 Tie Down and Lifting . . . . .	4-5
<b>SECTION 5 - EMERGENCY PROCEDURES</b>	
5.1 General . . . . .	5-1
5.2 Emergency Towing Procedures . . . . .	5-1
5.3 Emergency Controls and Their Locations . . . . .	5-1
5.4 Emergency Operation . . . . .	5-2
5.5 Incident Notification . . . . .	5-2
<b>SECTION 6 - INSPECTION AND REPAIR LOG</b>	

**LIST OF FIGURES**

<b>FIGURE NO.</b>	<b>TITLE</b>	<b>PAGE NO.</b>
2-1.	Daily Walk-Around Inspection - 2032E2/2632E2/2646E2/3246E2 (Sheet 1 of 2).....	2-4
2-1.	Daily Walk-Around Inspection - 2032E2/2632E2/2646E2/3246E2 (Sheet 2 of 2).....	2-5
2-2.	Daily Walk-Around Inspection - 1932E2 (Sheet 1 of 2).....	2-6
2-2.	Daily Walk-Around Inspection - 1932E2 (Sheet 2 of 2).....	2-7
3-1.	Ground Control Station.....	3-2
3-2.	Platform Control Station - Non Proportional Control.....	3-4
3-3.	Platform Control Station - Proportional Control.....	3-5
3-4.	Decal Location (1932E2).....	3-8
3-5.	Decal Location - 2032E2/2632E2/2646E2.....	3-11
3-6.	Decal Location - 3246E2.....	3-14
4-1.	Grade and Sideslope.....	4-3
4-2.	Lift and Tie Down.....	4-5
4-3.	Lifting Chart.....	4-6

**LIST OF TABLES**

<b>TABLE NO.</b>	<b>TITLE</b>	<b>PAGE NO.</b>
1-1	Minimum Safe Approach Distances (M.S.A.D.).....	1-3
2-1	Inspection and Maintenance Table.....	2-2
2-2	Maximum Cutout Height.....	2-3
3-1	Tilt.....	3-4
3-2	Decal Location Legend - 1932E2.....	3-9
3-3	Decal Location Legend - 1932E2 (Continued).....	3-10
3-4	Decal Location Legend - 2032E2/2632E2/2646E2.....	3-12
3-5	Decal Location Legend - 2032E2/2632E2/2646E2 (Continued).....	3-13
3-6	Decal Location Legend - 3246E2.....	3-15
3-7	Decal Location Legend - 3246E2 (Continued).....	3-16
4-1	Operating Specifications (CE and Australian).....	4-1
4-2	High Drive Cutout.....	4-3
4-3	Platform Capacity.....	4-5
6-1	Inspection and Repair Log.....	6-1

## SECTION 1. SAFETY PRECAUTIONS

### 1.1 GENERAL

This section outlines the necessary precautions for proper and safe machine usage and maintenance. In order to promote proper machine usage, it is mandatory that a daily routine is established based on the content of this manual. A maintenance program, using the information provided in this manual and the Service and Maintenance Manual, must also be established by a qualified person and must be followed to ensure that the machine is safe to operate.

The owner/user/operator/lessor/lessee of the machine should not accept operating responsibility until this manual has been read, training is accomplished, and operation of the machine has been completed under the supervision of an experienced and qualified operator.

These sections contain the responsibilities of the owner, user, operator, lessor, and lessee concerning safety, training, inspection, maintenance, application, and operation. If there are any questions with regard to safety, training, inspection, maintenance, application, and operation, please contact JLG Industries, Inc. ("JLG").

#### **⚠ WARNING**

**FAILURE TO COMPLY WITH THE SAFETY PRECAUTIONS LISTED IN THIS MANUAL COULD RESULT IN MACHINE DAMAGE, PROPERTY DAMAGE, PERSONAL INJURY OR DEATH.**

### 1.2 PRE-OPERATION

#### **Operator Training and Knowledge**

- The Operators and Safety Manual must be read in its entirety before operating the machine. For clarification, questions, or additional information regarding any portions of this manual, contact JLG Industries, Inc.

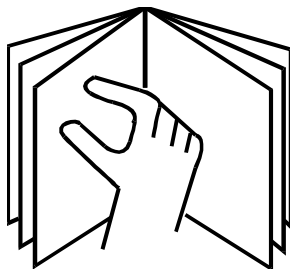

- An operator must not accept operating responsibilities until adequate training has been given by competent and authorized persons.

- Allow only those authorized and qualified personnel to operate the machine who have demonstrated that they understand the safe and proper operation and maintenance of the unit.
- Read, understand, and obey all DANGERS, WARNINGS, CAUTIONS, and operating instructions on the machine and in this manual.
- Ensure that the machine is to be used in a manner which is within the scope of its intended application as determined by JLG.
- All operating personnel must be familiar with the emergency controls and emergency operation of the machine as specified in this manual.
- Read, understand, and obey all applicable employer, local, and governmental regulations as they pertain to your utilization and application of the machine.

#### **Workplace Inspection**

- Precautions to avoid all hazards in the work area must be taken by the user before operation of the machine.
- Do not operate or raise the platform from a position on trucks, trailers, railway cars, floating vessels, scaffolds or other equipment unless the application is approved in writing by JLG.
- Before operation, check work area for overhead hazards such as electric lines, bridge cranes, and other potential overhead obstructions.
- Check floor surfaces for holes, bumps, drop-offs, obstructions, debris, concealed holes, and other potential hazards.
- Check the work area for hazardous locations. Do not operate the machine in hazardous environments unless approved for that purpose by JLG.
- Ensure that the ground conditions are adequate to support the maximum tire load indicated on the tire load decals located on the chassis adjacent to each wheel.
- Do not operate the machine when wind conditions exceed 28 mph (12.5 m/s).
- This machine can be operated in nominal ambient temperatures of 0° F to 104° F (-20° C to 40° C). Consult JLG to optimize operation outside of this temperature range.

#### **Machine Inspection**

- Do not operate this machine until the inspections and functional checks have been performed as specified in Section 2 of this manual.

## SECTION 1 - SAFETY PRECAUTIONS

- Do not operate this machine until it has been serviced and maintained according to the maintenance and inspection requirements as specified in the machine's Service and Maintenance Manual.
- Ensure all safety devices are operating properly. Modification of these devices is a safety violation.

### **⚠ WARNING**

#### **MODIFICATION OR ALTERATION OF AN AERIAL WORK PLATFORM SHALL BE MADE ONLY WITH PRIOR WRITTEN PERMISSION FROM THE MANUFACTURER**

- Do not operate any machine on which the safety or instruction placards or decals are missing or illegible.
- Check the machine for modifications to original components. Ensure that any modifications have been approved by JLG.
- Avoid accumulation of debris on platform deck. Keep mud, oil, grease, and other slippery substances from footwear and platform deck.

## 1.3 OPERATION

### General

- Do not use the machine for any purpose other than positioning personnel, their tools, and equipment.
  - Before operation, the user must be familiar with the machine capabilities and operating characteristics of all functions.
  - Never operate a malfunctioning machine. If a malfunction occurs, shut down the machine. Remove the unit from service and notify the proper authorities.
  - Do not remove, modify, or disable any safety devices.
  - Never slam a control switch or lever through neutral to an opposite direction. Always return switch to neutral and stop before moving the switch to the next function. Operate controls with slow and even pressure.
  - Hydraulic cylinders should never be left at end of travel (fully extended or fully retracted) before shutdown or for long periods of time. Always "bump" control in opposite direction slightly when function reaches end of travel. This applies both to machines in operation or in the stowed position.
  - Do not allow personnel to tamper with or operate the machine from the ground with personnel in the platform, except in an emergency.
  - Do not carry materials directly on platform railing unless approved by JLG.
- When two or more persons are in the platform, the operator shall be responsible for all machine operations.
  - Always ensure that power tools are properly stowed and never left hanging by their cord from the platform work area.
  - Do not assist a stuck or disabled machine by pushing or pulling except by pulling at the chassis tie-down lugs.
  - Stow scissor arm assembly and shut off all power before leaving machine.

### Trip and Fall Hazards

- JLG Industries, Inc. recommends that all persons in the platform wear a full body harness with a lanyard attached to an authorized lanyard anchorage point while operating this machine. For further information regarding fall protection requirements on JLG products, contact JLG Industries, Inc.

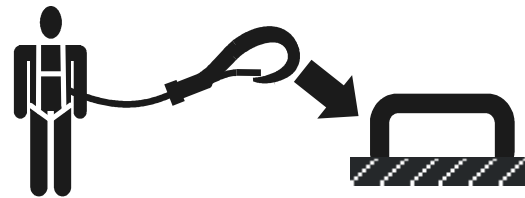

- Prior to operation, ensure all gates are fastened and secured in their proper position. Identify the designated lanyard anchorage point(s) at the platform and securely attach the lanyard. Attach only one (1) lanyard per lanyard anchorage point.

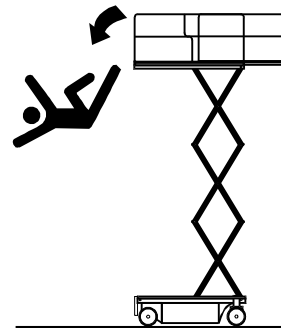

- Keep both feet firmly positioned on the platform floor at all times. Never position ladders, boxes, steps, planks, or similar items on unit to provide additional reach for any purpose.
- Never use the scissor arm assembly to gain access to or leave the platform.

- Use extreme caution when entering or leaving platform. Ensure that the scissor arm assembly is fully lowered. Face the machine when entering or leaving the platform. Always maintain “three point contact” with the machine, using two hands and one foot or two feet and one hand at all times during entry and exit.
- Platform-to-structure transfers at elevated positions are discouraged. Where transfer is necessary, enter/exit through the gate only with the platform within 1 foot (0.3m) of a safe and secure structure. 100% tie-off is also required in this situation utilizing two lanyards. One lanyard must be attached to the platform with the second lanyard attached to the structure. The lanyard connected to the platform must not be disconnected until such time the transfer to the structure is safe and complete.
- Keep oil, mud, and slippery substances cleaned from footwear and the platform floor.

**Electrocution Hazards**

- This machine is not insulated and does not provide protection from contact with an electrically charged conductor.

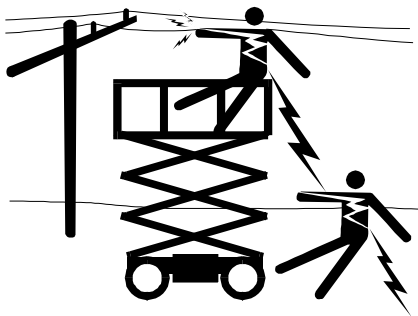
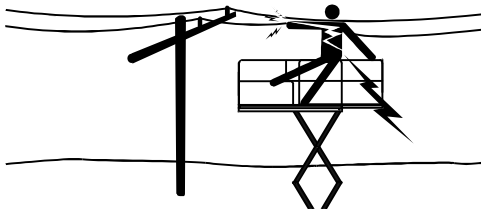

- Maintain safe clearance from electrical lines, apparatus, or any energized (exposed or insulated) parts in accordance with the Minimum Safe Approach Distance (MSAD) as specified in Table 1-1. Allow for machine movement and electrical line swaying.

**Table 1-1. Minimum Safe Approach Distances (M.S.A.D.)**

Voltage Range (Phase to Phase)	MINIMUM SAFE APPROACH DISTANCE in Feet (Meters)
0 to 300V	AVOID CONTACT
Over 300V to 50 KV	10 (3)
Over 50KV to 200 KV	15 (5)
Over 200 KV to 350 KV	20 (6)
Over 350 KV to 500 KV	25 (8)
Over 500 KV to 750 KV	35 (11)
Over 750 KV to 1000 KV	45 (14)

**NOTE: This requirement shall apply except where employer, local or governmental regulations are more stringent.**

- Maintain a clearance of at least 10 ft. (3m) between any part of the machine and its occupants, their tools, and their equipment from any electrical line or apparatus carrying up to 50,000 volts. One foot additional clearance is required for every additional 30,000 volts or less.

**⚠ DANGER**

**DO NOT MANEUVER MACHINE OR PERSONNEL INSIDE PROHIBITED ZONE (MSAD). ASSUME ALL ELECTRICAL PARTS AND WIRING ARE ENERGIZED UNLESS KNOWN OTHERWISE.**

**Tipping Hazards**

- Ensure that the ground conditions are adequate to support the maximum tire load indicated on the tire load decals located on the chassis adjacent to each wheel. Do not travel on unsupported surfaces.
- The user should be familiar with the driving surface before driving. Do not exceed the allowable sideslope and grade while driving.

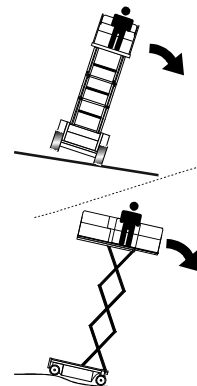

Do not elevate platform or drive with platform elevated while on or near a sloping, uneven, or soft surface. Ensure machine is positioned on a firm, level and uniformly supported surface before elevating platform or driving with the platform in the elevated position.

## SECTION 1 - SAFETY PRECAUTIONS

---

- Before driving on floors, bridges, trucks, and other surfaces, check allowable capacity of the surfaces.
- Never exceed the maximum work load as specified on the platform. Distribute loads evenly on platform floor. Keep all loads within the confines of the platform, unless authorized by JLG.
- Keep the chassis of the machine a minimum of 2 ft. (0.6m) from holes, bumps, drop-offs, obstructions, debris, concealed holes, and other potential hazards at the ground level.
- Never attempt to use the machine as a crane. Do not tie-off machine to any adjacent structure. Never attach wire, cable, or any similar items to platform.
- Do not operate the machine when wind conditions exceed 28 mph (12.5 m/s). Unless otherwise specified on machine or accessory.
- Do not cover the platform sides or carry large surface-area items in the platform when operating outdoors. The addition of such items increases the exposed wind area of the machine.
- Do not increase the platform size with unauthorized deck extensions or attachments.
- If scissor arm assembly or platform is caught so that one or more wheels are off the ground, all persons must be removed before attempting to free the machine. Use cranes, forklift trucks, or other appropriate equipment to stabilize machine and remove personnel.

### Crushing and Collision Hazards

---

- Approved head gear must be worn by all operating and ground personnel.
- Keep hands and limbs out of the scissor arm assembly during operation.
- Watch for obstructions around machine and overhead when driving. Check clearances above, on sides, and bottom of platform when lifting or lowering platform..

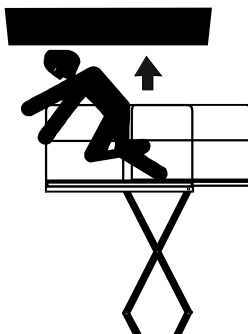

- During operation, keep all body parts inside platform railing.
- Always post a lookout when driving in areas where vision is obstructed.

- Keep non-operating personnel at least 6 ft. (1.8m) away from machine during all driving operations.
- Under all travel conditions, the operator must limit travel speed according to conditions of ground surface, congestion, visibility, slope, location of personnel, and other factors causing hazards of collision or injury to personnel.
- Be aware of stopping distances in all drive speeds. When driving in high speed, switch to low speed before stopping. Travel grades in low speed only.
- Do not use high speed drive in restricted or close quarters or when driving in reverse.
- Exercise extreme caution at all times to prevent obstacles from striking or interfering with operating controls and persons in the platform.
- Ensure that operators of other overhead and floor level machines are aware of the aerial work platform's presence. Disconnect power to overhead cranes. Barricade floor area if necessary.
- Avoid operating over ground personnel. Warn personnel not to work, stand, or walk under a raised platform. Position barricades on floor as necessary.

---

### 1.4 TOWING, LIFTING, AND HAULING

- Never allow personnel in platform while towing, lifting, or hauling.
- This machine should not be towed, except in the event of emergency, malfunction, power failure, or loading/unloading. Refer to Section 6 for emergency towing procedures.
- Ensure platform is fully retracted and completely empty of tools prior to towing, lifting or hauling.
- When lifting machine with a forklift, position forks only at designated areas of the machine. Lift with a forklift of adequate capacity.
- Refer to Section 4 for lifting information.

---

### 1.5 ADDITIONAL HAZARDS / SAFETY

- Do not use machine as a ground for welding.
- When performing welding or metal cutting operations, precautions must be taken to protect the chassis from direct exposure to weld and metal cutting spatter.
- Do not refuel the machine with the engine running (where applicable).
- Battery fluid is highly corrosive. Avoid contact with skin and clothing at all times.

Charge batteries only in a well ventilated area.

## **SECTION 2. USER RESPONSIBILITIES, MACHINE PREPARATION, AND INSPECTION**

---

### **2.1 PERSONNEL TRAINING**

The aerial platform is a personnel handling device; so it is necessary that it be operated and maintained only by trained personnel.

Persons under the influence of drugs or alcohol or who are subject to seizures, dizziness or loss of physical control must not operate this machine.

#### **Operator Training**

---

Operator training must cover:

1. Use and limitations of the controls in the platform and at the ground, emergency controls and safety systems.
2. Control labels, instructions, and warnings on the machine.
3. Rules of the employer and government regulations.
4. Use of approved fall protection device.
5. Enough knowledge of the mechanical operation of the machine to recognize a malfunction or potential malfunction.

6. The safest means to operate the machine where overhead obstructions, other moving equipment, and obstacles, depressions, holes, drop-offs.
7. Means to avoid the hazards of unprotected electrical conductors.
8. Specific job requirements or machine application.

#### **Training Supervision**

---

Training must be done under the supervision of a qualified person in an open area free of obstructions until the trainee has developed the ability to safely control and operate the machine.

#### **Operator Responsibility**

---

The operator must be instructed that he/she has the responsibility and authority to shut down the machine in case of a malfunction or other unsafe condition of either the machine or the job site.

**NOTE:** *The Manufacturer or Distributor will provide qualified people for training assistance with the first unit(s) delivered and from that time forward as requested by the user or his/her personnel.*

## SECTION 2 - USER RESPONSIBILITIES, MACHINE PREPARATION, AND INSPECTION

### 2.2 PREPARATION, INSPECTION, AND MAINTENANCE

The following table covers the periodic machine inspections and maintenance recommended by JLG Industries, Inc. Consult local regulations for further requirements for aerial work platforms. The frequency of inspections and

maintenance must be increased as necessary when the machine is used in a harsh or hostile environment, if the machine is used with increased frequency, or if the machine is used in a severe manner.

**Table 2-1. Inspection and Maintenance Table**

Type	Frequency	Primary Responsibility	Service Qualification	Reference
Pre-Start Inspection	Before using each day; or whenever there's an Operator change.	User or Operator	User or Operator	Operator and Safety Manual
Pre-Delivery Inspection (See Note)	Before each sale, lease, or rental delivery.	Owner, Dealer, or User	Qualified JLG Mechanic	Service and Maintenance Manual and applicable JLG inspection form
Frequent Inspection	In service for 3 months or 150 hours, whichever comes first; or Out of service for a period of more than 3 months; or Purchased used.	Owner, Dealer, or User	Qualified JLG Mechanic	Service and Maintenance Manual and applicable JLG inspection form
Annual Machine Inspection	Annually, no later than 13 months from the date of prior inspection.	Owner, Dealer, or User	Factory-Certified Service Technician*	Service and Maintenance Manual and applicable JLG inspection form
Preventative Maintenance	At intervals as specified in the Service and Maintenance Manual.	Owner, Dealer, or User	Qualified JLG Mechanic	Service and Maintenance Manual
<b>NOTE:</b> Inspection forms are available from JLG. Use the Service and Maintenance Manual to perform inspections.				
* JLG Industries, Inc. recognizes a Factory-Certified Service Technician as a person who has successfully completed the JLG Service Training School for the specific JLG product model.				

**Pre-Start Inspection**

The Pre-Start Inspection should include each of the following:

1. **Cleanliness** – Check all surfaces for leakage (oil, fuel, or battery fluid) or foreign objects. Report any leakage to the proper maintenance personnel.
2. **Decals and Placards** – Check all for cleanliness and legibility. Make sure none of the decals and placards are missing. Make sure all illegible decals and placards are cleaned or replaced.
3. **Operators and Safety Manuals** – Make sure a copy of the Operator and Safety Manual, EMI Safety Manual (Domestic only), and ANSI Manual of Responsibilities (Domestic only) is enclosed in the weather resistant storage container.
4. **“Walk-Around” Inspection** – Refer to Figures 1 and 2.
5. **Battery** – Charge as required.
6. **Fuel** (Combustion Engine Powered Machines) – Add the proper fuel as necessary.
7. **Hydraulic Oil** – Check the hydraulic oil level. Ensure hydraulic oil is added as required.
8. **Function Check** – Once the “Walk-Around” Inspection is complete, perform a functional check of all systems in an area free of overhead and ground level obstructions. Refer to Section 4 for more specific instructions.

**⚠ WARNING**

**IF THE MACHINE DOES NOT OPERATE PROPERLY, TURN OFF THE MACHINE IMMEDIATELY! REPORT THE PROBLEM TO THE PROPER MAINTENANCE PERSONNEL. DO NOT OPERATE THE MACHINE UNTIL IT IS DECLARED SAFE FOR OPERATION.**

**Function Check**

Perform the Function Check as follows:

1. From the ground control panel with no load in the platform:
  - a. Check that all guards protecting the switches or locks are in place;
  - b. Operate all functions and check all limiting and cut-out switches; See Table 2-2, Maximum Cut-out Height
  - c. Check auxiliary power (or manual descent);
  - d. Ensure that all machine functions are disabled when the Emergency Stop Button is activated.

**Table 2-2. Maximum Cutout Height**

Model	High Drive Cutout (Maximum Height)	Drive Cutout
1932E2	2.6 m	N/A
2032E2	2.1 m	N/A
2632E2 (Australian Only)	2.9 m	N/A
2632E2/2646E2	2.6 m	N/A
3246E2	2.8 m	N/A

2. From the platform control console:
  - a. Ensure that the control console is firmly secured in the proper location;
  - b. Check that all guards protecting the switches or locks are in place;
  - c. Operate all functions and check all limiting and cut-out switches;
  - d. Ensure that all machine functions are disabled when the Emergency Stop Button is pushed in.
3. With the platform in the transport (stowed) position:
  - a. Drive the machine on a grade, not to exceed the rated gradeability, and stop to ensure the brakes hold;

Check the tilt sensor alarm to ensure proper operation.

**SECTION 2 - USER RESPONSIBILITIES, MACHINE PREPARATION, AND INSPECTION**

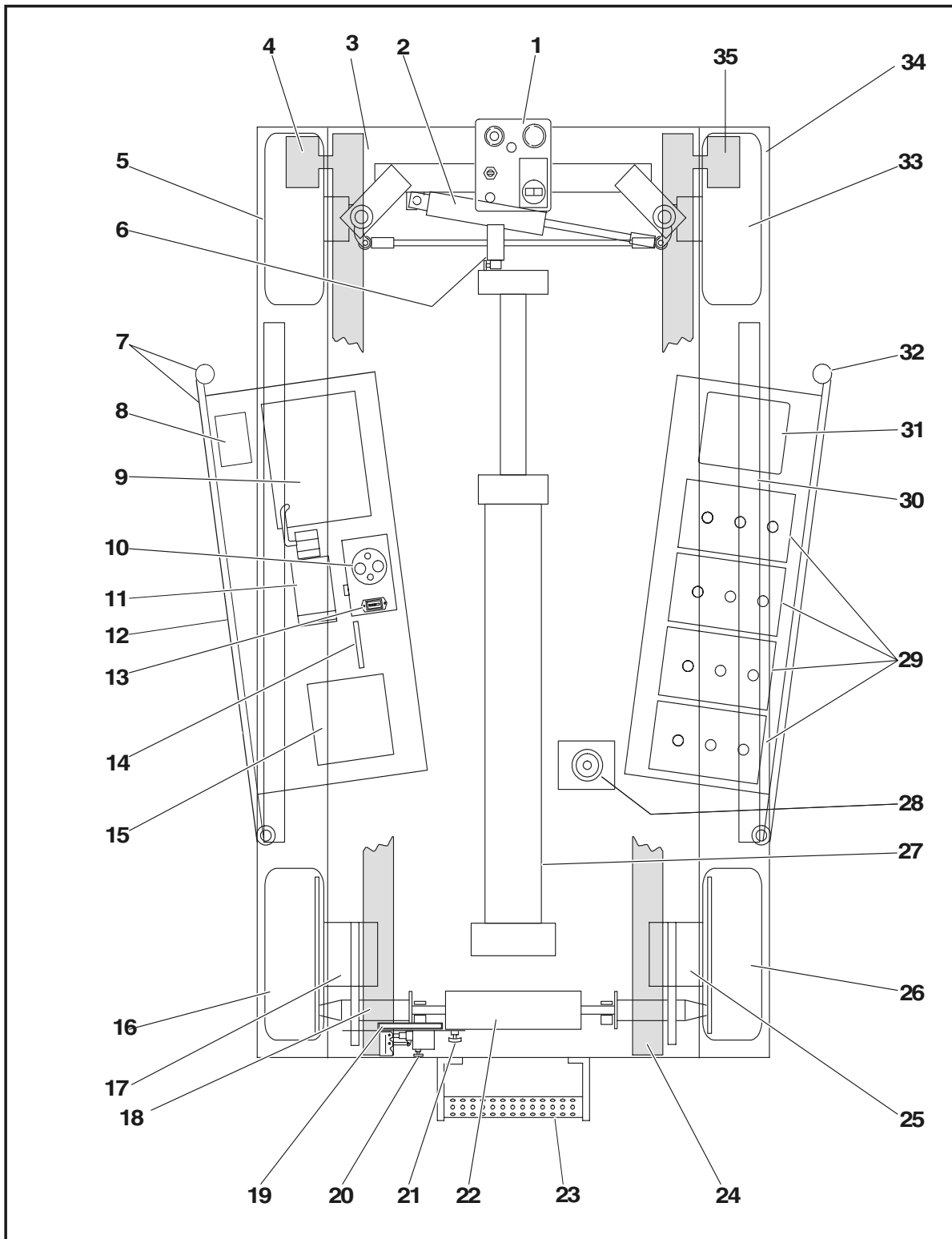

**Figure 2-1. Daily Walk-Around Inspection - 2032E2/2632E2/2646E2/3246E2 (Sheet 1 of 2).**

## SECTION 2 - USER RESPONSIBILITIES, MACHINE PREPARATION, AND INSPECTION

### GENERAL

Begin the "Walk-Around Inspection" at Item 1, as noted on the diagram. Continue Left (counterclockwise viewed from top) checking each item in sequence for the conditions listed in the following checklist.

#### **⚠ WARNING**

**TO AVOID POSSIBLE INJURY, BE SURE MACHINE POWER IS "OFF" DURING "WALK-AROUND INSPECTION".**

#### **⚠ IMPORTANT**

**DO NOT OVERLOOK VISUAL INSPECTION OF CHASSIS UNDERSIDE. CHECKING THIS AREA OFTEN RESULTS IN DISCOVERY OF CONDITIONS WHICH COULD CAUSE EXTENSIVE MACHINE DAMAGE.**

**NOTE:** *On each item, make sure there are no loose or missing parts, that they are securely fastened, and that no visible damage exists in addition to any other criteria mentioned.*

1. Platform Control Console - Placard secure and legible, control lever and switches return to neutral, control lever lock and emergency stop switch function properly, manual in storage box.
2. Spindle, Tie Rod and Steer Linkage (left front) - See Note
3. Safety Prop - See Note
4. Sizzor Arms and Sliding Wear Pads - See Note
5. Wheel and Tire Assembly, Left Front - See Note
6. Drive Cutout Switch - See Note
7. Compartment Cover and Latches - See Note
8. Ground Controls - Placard secure and legible, control switches return to neutral position, emergency stop switch functions properly. Control markings legible.
9. Hydraulic Reservoir - Recommended hydraulic fluid level on level indicator on tank. Breather cap secure and working.
10. Hydraulic Filter - See Note
11. Hydraulic Pump/Motor - See Note
12. Pothole Protection System - See Note
13. Hourmeter - See Note
14. Wire Installation - See Note
15. Control Valve Installation - No unsupported wires or hoses; no damaged or broken wires.
16. Wheel and Tire Assembly, Left Rear - See Note
17. Drive Motor, Left Rear - See Note
18. Sizzor Arms and Sliding Wear Pads - See Note
19. Handle for Manual Descent (2646E2/3246E2) - See Note
20. Manual Descent Pump (2632E2/2646E2/3246E2) - See Note
21. Manual Descent (2032E2) - See Note
22. Brake Cylinder - See Note
23. Ladder - See Note
24. Sizzor Arms and Sliding Wear Pads - See Note
25. Drive Motor, Right Rear - See Note
26. Wheel and Tire Assembly, Right Rear - See Note
27. Lift Cylinder - See Note
28. Tilt Switch - See Note
29. Battery Compartment - Proper electrolyte level.
30. Pothole Protection System - See Note
31. Battery Charger - See Note
32. Compartment Cover and Latches - See Note
33. Wheel and Tire Assembly, Right Front - See Note
34. Platform/Handrail Installation (Not Shown) - See Note
35. Sizzor Arms and Sliding Wear Pads - See Note

Figure 2-1. Daily Walk-Around Inspection - 2032E2/2632E2/2646E2/3246E2 (Sheet 2 of 2).

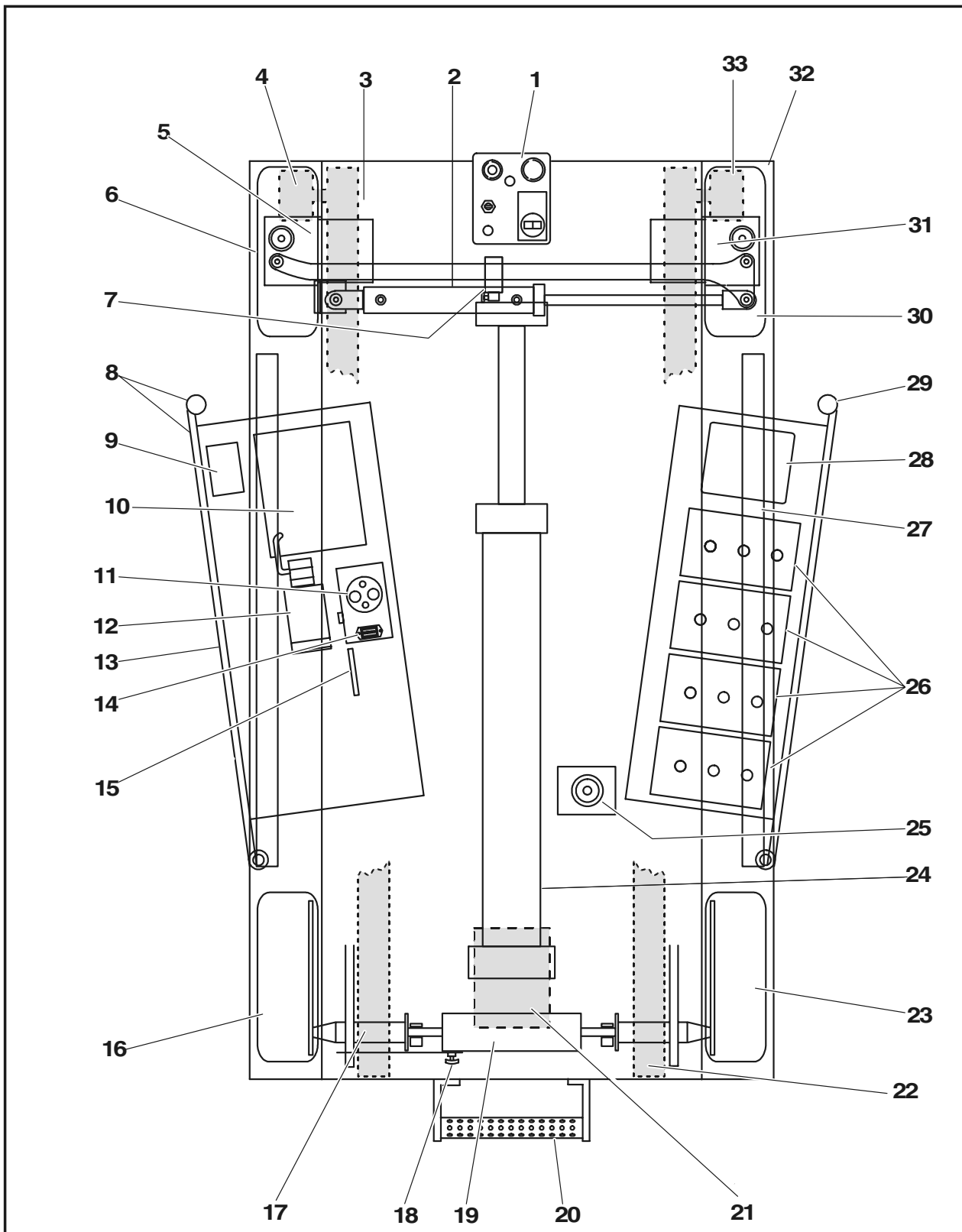

**Figure 2-2. Daily Walk-Around Inspection - 1932E2 (Sheet 1 of 2).**

**GENERAL**

Begin the "Walk-Around Inspection" at Item 1, as noted on the diagram. Continue Left (counterclockwise viewed from top) checking each item in sequence for the conditions listed in the following checklist.

**⚠ WARNING**

**TO AVOID POSSIBLE INJURY, BE SURE MACHINE POWER IS "OFF" DURING "WALK-AROUND INSPECTION".**

**⚠ IMPORTANT**

**DO NOT OVERLOOK VISUAL INSPECTION OF CHASSIS UNDERSIDE. CHECKING THIS AREA OFTEN RESULTS IN DISCOVERY OF CONDITIONS WHICH COULD CAUSE EXTENSIVE MACHINE DAMAGE.**

**NOTE:** *On each item, make sure there are no loose or missing parts, that they are securely fastened, and that no visible damage exists in addition to any other criteria mentioned.*

1. Platform Control Console - Placard secure and legible, control lever and switches return to neutral, control lever lock and emergency stop switch function properly, manual in storage box.
2. Spindle, Tie Rod and Steer Linkage (left front) - See Note
3. Safety Prop - See Note
4. Sizzor Arms and Sliding Wear Pads - See Note
5. Drive Motor, Left Front - See Note
6. Wheel and Tire Assembly, Left Front - See Note
7. Drive Cutout Switch - See Note
8. Compartment Cover and Latches - See Note
9. Ground Controls - Placard secure and legible, control switches return to neutral position, emergency stop switch functions properly. Control markings legible.
10. Hydraulic Reservoir - Recommended hydraulic fluid level on level indicator on tank. Breather cap secure and working.
11. Hydraulic Filter - See Note
12. Hydraulic Pump/Motor - See Note
13. Pothole Protection System - See Note
14. Hourmeter - See Note
15. Wire Installation - See Note
16. Wheel and Tire Assembly, Left Rear - See Note
17. Sizzor Arms and Sliding Wear Pads - See Note
18. Manual Descent - See Note
19. Brake Cylinder - See Note
20. Ladder - See Note
21. Control Valve Installation - No unsupported wires or hoses; no damaged or broken wires.
22. Sizzor Arms and Sliding Wear Pads - See Note
23. Wheel and Tire Assembly, Right Rear - See Note
24. Lift Cylinder - See Note
25. Tilt Switch - See Note
26. Battery Compartment - Proper electrolyte level
27. Pothole Protection System - See Note
28. Battery Charger - See Note
29. Compartment Cover and Latches - See Note
30. Wheel and Tire Assembly, Right Front - See Note
31. Drive Motor, Right Rear - See Note
32. Platform/Handrail Installation (Not Shown) - See Note
33. Sizzor Arms and Sliding Wear Pads - See Note

**Figure 2-2. Daily Walk-Around Inspection - 1932E2 (Sheet 2 of 2).**

**This page left blank intentionally.**

## SECTION 3. USER RESPONSIBILITIES AND MACHINE CONTROL

### 3.1 GENERAL

#### **⚠ IMPORTANT**

**SINCE THE MANUFACTURER HAS NO DIRECT CONTROL OVER MACHINE APPLICATION AND OPERATION, CONFORMANCE WITH GOOD SAFETY PRACTICES IN THESE AREAS IS THE RESPONSIBILITY OF THE USER AND HIS OPERATING PERSONNEL.**

This section provides the necessary information needed to understand control functions. Included in this section are the operating characteristics and limitations, and functions and purposes of controls and indicators. It is important that the user read and understand the proper procedures before operating the machine. These procedures will aid in obtaining optimum service life and safe operation.

### 3.2 PERSONNEL TRAINING

The scissor lift is a personnel handling device; therefore, it is essential that it be operated and maintained only by authorized and qualified personnel who have demonstrated that they understand the proper use and maintenance of the machine. It is important that all personnel who are assigned to and responsible for the operation and maintenance of the machine undergo a thorough training program and check out period in order to become familiar with the characteristics prior to operating the machine.

Persons under the influence of drugs or alcohol or who are subject to seizures, dizziness or loss of physical control must not be permitted to operate the machine.

#### **Operator Training**

**Operator training must include instruction in the following:**

1. Use and limitations of the platform controls, ground controls, emergency controls and safety systems.
2. Knowledge and understanding of this manual and of the control markings, instructions and warnings on the machine itself.
3. Knowledge and understanding of all safety work rules of the employer and of Federal, State and Local Statutes, including training in the recognition and avoidance of potential hazards in the work place; with particular attention to the work to be performed.
4. Proper use of all required personnel safety equipment.

5. Sufficient knowledge of the mechanical operation of the machine to recognize a malfunction or potential malfunction.
6. The safest means to operate near overhead obstructions, other moving equipment, obstacles, depressions, holes, dropoffs, etc. on the supporting surface.
7. Means to avoid the hazards of unprotected electrical conductors.
8. Any other requirements of a specific job or machine application.

#### **Training Supervision**

Training must be done under the supervision of a qualified operator or supervisor in an open area free of obstructions until the trainee has developed the ability to safely control a scissor lift in congested work locations.

#### **Operator Responsibility**

The operator must be instructed that he has the responsibility and authority to shut down the machine in case of a malfunction or other unsafe condition of either the machine or the job site and to request further information from his supervisor or JLG Distributor before proceeding.

**NOTE:** *Manufacturer or Distributor will provide qualified persons for training assistance with first unit(s) delivered and thereafter as requested by user or his personnel.*

### 3.3 OPERATING CHARACTERISTICS AND LIMITATIONS

#### **General**

A thorough knowledge of the operating characteristics and limitations of the machine is always the first requirement for any user, regardless of user's experience with similar types of equipment.

#### **Placards**

Important points to remember during operation are provided at the control stations by DANGER, WARNING, CAUTION, IMPORTANT and INSTRUCTION placards. This information is placed at various locations for the express purpose of alerting personnel of potential hazards constituted by the operating characteristics and load limitations of the machine. See foreword for definitions of the above placards.

## SECTION 3 - USER RESPONSIBILITIES AND MACHINE CONTROL

### Capacities

Raising platform with or without any load in platform, is based on the following criteria:

1. Machine is positioned on a smooth, firm and level surface.
2. Load is within manufacturer's rated capacity.
3. All machine systems are functioning properly.

### Stability

This machine, as originally manufactured by JLG and operated within its rated capacity on a smooth, firm and level supporting surface, provides a stable aerial platform for all platform positions.

## 3.4 CONTROLS AND INDICATORS FOR NON PROPORTIONAL CONTROL

### Battery Charger

**NOTE:** If batteries are run down to under 6 volts, the supplied battery charger will not pick up the charge.

The battery charger is located in the right side battery door. The charger is a 20 Amp, SCR-style charger equipped with a manual switch that allows the operator to select 110-125 Volt input or 220-250 Volt input. A rocker switch circuit breaker is included to reset the charger in the event of a loss of power. LED's on the front panel of the charger indicate the status of charger operation (Charge Complete, 80% Charge, Incomplete Charge, Charger On, Abnormal Cycle)

### Ground Control Station

#### **⚠ WARNING**

DO NOT OPERATE FROM GROUND CONTROL STATION WITH PERSONNEL IN THE PLATFORM EXCEPT IN AN EMERGENCY.

#### **⚠ WARNING**

PERFORM AS MANY PRE-OPERATIONAL CHECKS AND INSPECTIONS FROM THE GROUND CONTROL STATION AS POSSIBLE. REFER TO SECTION 2 FOR PRE-OPERATIONAL CHECKS AND INSPECTIONS.

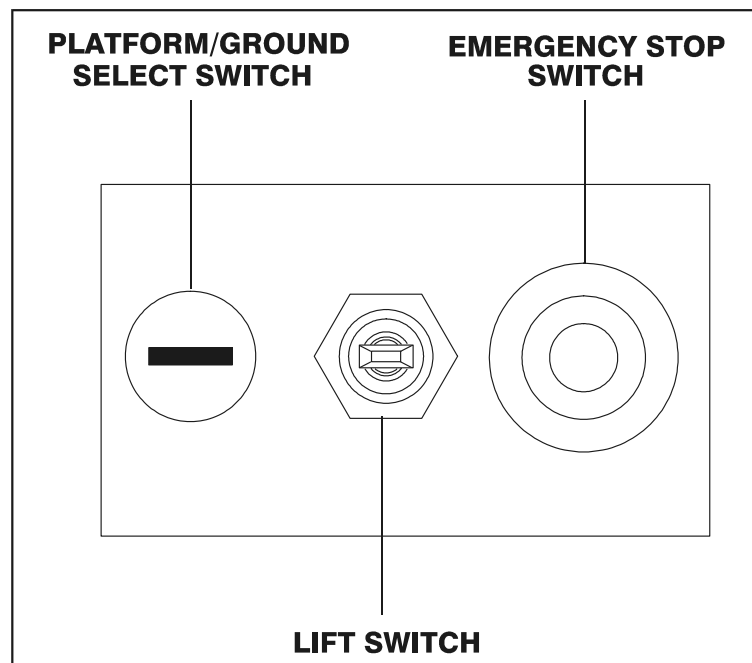

Figure 3-1. Ground Control Station

1. Power Selector Switch  
A three position, key-operated power selector switch supplies operating power to the platform or ground controls, as selected. When positioned to platform, the switch provides power to the emergency stop switch at the platform controls. When positioned to ground, the switch provides power to the emergency stop switch at the ground controls. With the power selector switch in the center off position, power is shut off to both platform and ground controls.

**NOTE:** *With the power selector switch in the off position, the key can be removed in order to avoid unauthorized use of the machine.*

*Low speed is the default speed for all functions when the platform is fully lowered. When the platform is elevated, all functions operate in creep speed only.*

2. Emergency Stop Switch  
A two-position, red, mushroom-shaped emergency stop switch, when positioned to on (pulled out) with the power selector switch positioned to ground, furnishes operating power to the ground control station. In addition, the switch can be used to turn off power to the function controls in the event of an emergency. Power is turned on by pulling the switch out (on), and is turned off by pushing the switch in (off).
3. Lift Switch  
A three-position, momentary-contact switch provides raising and lowering of the platform when positioned to up or down.
4. Circuit Breaker  
A push button reset 15 Amp circuit breaker, located behind the pump/motor in the left side door, returns interrupted power to the machine functions when depressed.
5. Hourmeter  
The machine may be equipped with an hourmeter to indicate the number of hours the machine has been operated. The hourmeter operates when a machine function is operating or when key switch and emergency stop switch are on.

### Platform Control Station

---

1. Emergency Stop Switch  
A two-position, red, mushroom-shaped emergency stop switch functions to provide power to the platform control station and also to turn off power to the platform function controls in the event of an emergency. With the power selector switch positioned to platform, power is turned on by pulling the switch out (on), and is turned off by pushing the switch in (off).

2. Enable Switch  
The enable switch is located on the left side of the platform control box. This switch must be depressed and held before and during actuation of the lift function and for the duration of lift. The enable switch works in conjunction with the lift switch.
3. Drive  
The joystick is used to drive the machine forward and reverse. To drive, the red trigger on the front of the joystick must be depressed and held. Then the joystick must be pushed forward for forward travel or pulled backward for reverse travel. The adjustment between low and high speed is determined by the joystick travel. When motor is first activated you are in low speed, high speed is achieved by moving the joystick to the complete forward position.

**NOTE:** *When the machine is raised, and a door is opened, the machine will not drive.*

*The drive system may make an occasional cavitation noise when driving with steer wheels turned all the way in one direction or while going down hill. This noise is a byproduct of the drive system.*

4. Lift  
The lift switch, when used in conjunction with the enable switch, will raise or lower the machine. Lift is activated by pressing and holding the enable and moving the lift switch forward (lift up) or backward (lift down).

### CAUTION

**DO NOT "LIFT DOWN" WITHOUT COMPLETELY RETRACTING THE PLATFORM EXTENSION.**

5. Steer Switch  
The thumb-operated steer switch, located on top of the joystick controller, activates the steer wheels in the direction the switch is moved (left or right).

### CAUTION

**DO NOT USE HIGH DRIVE SPEED WHEN DRIVING IN CLOSE QUARTERS OR WHEN DRIVING IN REVERSE.**

6. Drive Speed Select Switch  
The speed select switch is a toggle switch which allows you to select high or low speed.

**NOTE:** *The High Drive Speed switch will cut-out when the platform is raised above the stowed position, returning drive speed to low until the platform is lowered completely.*

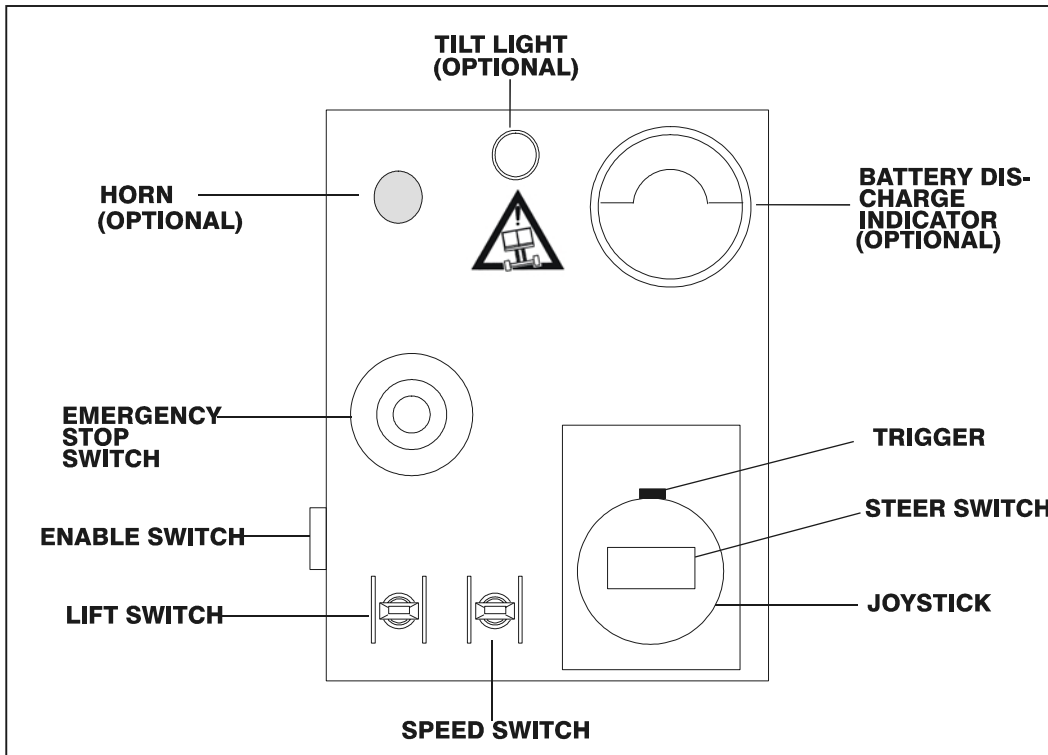

Figure 3-2. Platform Control Station - Non Proportional Control

**CAUTION**

DO NOT OPERATE MACHINE IF HIGH DRIVE SPEED OPERATES WHEN PLATFORM IS RAISED ABOVE THE STOWED POSITION.

**NOTE:** The machine is equipped with a Pothole Protection System which lowers automatically when the platform is raised. The Pothole Protection System will also lower when either of the doors are opened, but only on the side of the opened door and this will not provide tip over protection. If the Pothole Protection System does not fully lower, the DRIVE function is cut out until the platform is completely lowered.

- 7. Tilt Alarm Warning Horn. (If Equipped)  
The Tilt Alarm Warning is activated by the Tilt Alarm Switch when the chassis is on a slope. See Figure 3-1, Tilt, for degree of tilt per model.

**WARNING**

IF TILT ALARM IS ON WHEN PLATFORM IS RAISED, LOWER PLATFORM COMPLETELY, THEN REPOSITION MACHINE SO THAT IT IS LEVEL BEFORE RAISING PLATFORM.

- 8. Tilt Alarm Warning Light. (If Equipped)  
A red warning light on the control box panel will illuminate when the chassis is on a slope. See Figure 3-1, Tilt, for degree of tilt per model
- 9. Horn. (If Equipped)  
This push button switch, when activated, permits the operator to warn jobsite personnel when the machine is operating in the area.
- 10. Battery Discharge Indicator  
The battery discharge indicator is a gauge that provides a visual indication of the condition of the batteries.

Table 3-1. Tilt

1932E2/2032E2	2632E2/2646E2/3246E2
1.5 Degrees	2 Degrees

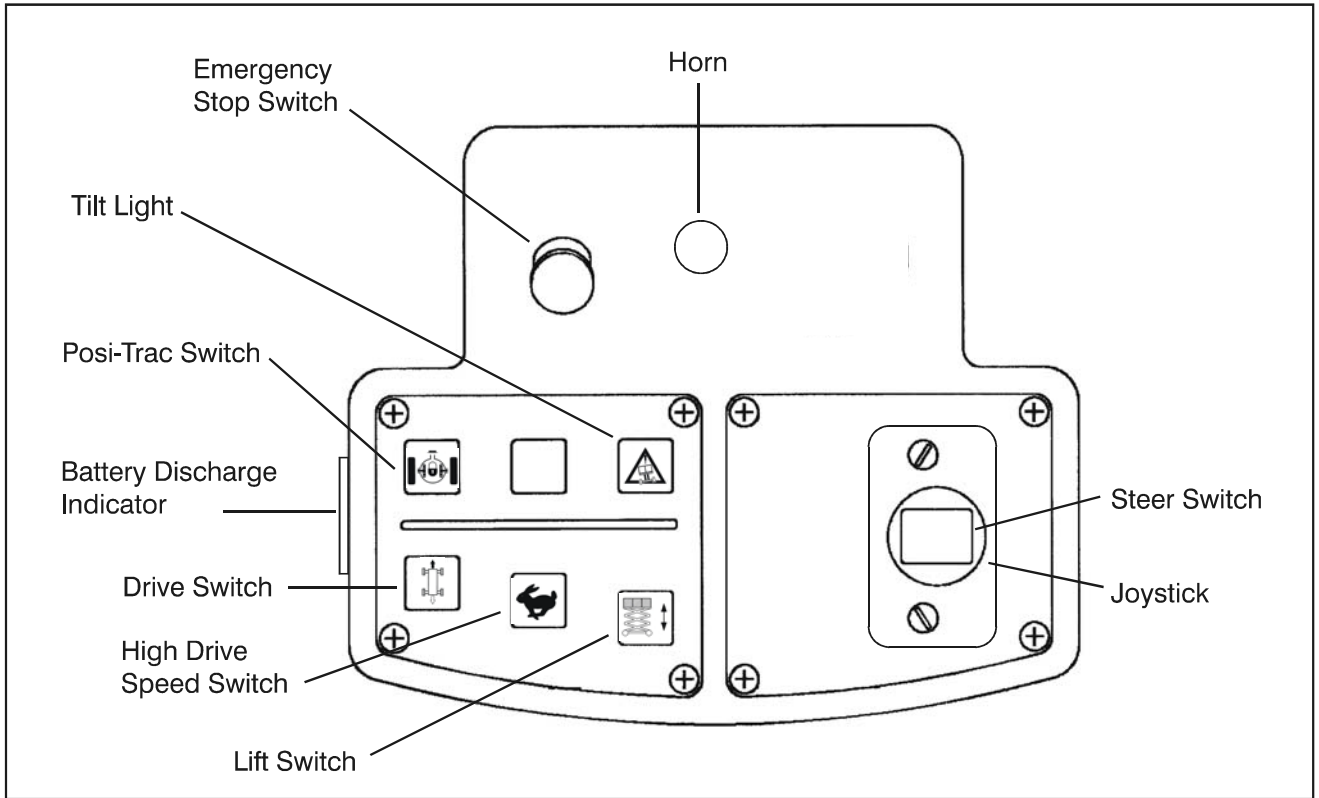

Figure 3-3. Platform Control Station - Proportional Control

### 3.5 CONTROLS AND INDICATORS FOR PROPORTIONAL CONTROL

The machine is equipped with control panels that use symbols instead of words to indicate control functions. Refer to Symbols figure for these symbols and their corresponding functions.

#### JLG SMART™ System

The machine is controlled by the JLG SMART™ System, a 24 volt, multiplex motor controller which works in conjunction with a joystick and several switches to operate all machine functions.

Special operating characteristics of the JLG SMART™ System are noted where applicable. Special attention should be paid to these operating characteristics, as they may be somewhat different from those on previous JLG machines.

#### **⚠ IMPORTANT**

IT IS A GOOD PRACTICE TO AVOID PRESSURE-WASHING ELECTRICAL/ELECTRONIC COMPONENTS. SHOULD PRESSURE-WASHING BE UTILIZED TO WASH AREAS CONTAINING ELECTRICAL/ELECTRONIC COMPONENTS, JLG INDUSTRIES, INC. RECOMMENDS A MAXIMUM PRESSURE OF 750 PSI (52 BAR) AT A MINIMUM DISTANCE OF 12 INCHES (30.5 CM) AWAY FROM THESE COMPONENTS. IF ELECTRICAL/ELECTRONIC COMPONENTS ARE SPRAYED, SPRAYING MUST NOT BE DIRECT AND BE FOR BRIEF TIME PERIODS TO AVOID HEAVY SATURATION.

#### Ground Control Station

**NOTE:** Refer to the Ground Control Station for Non Proportional Control machines.

### Platform Control Station

---

1. **Emergency Stop Switch** - A two-position, red, mushroom-shaped emergency stop switch functions to provide power to the platform control station and also to turn off power to the platform function controls in the event of an emergency. With the power selector switch positioned to platform, power is turned on by pulling the switch out (on), and is turned off by pushing the switch in (off). Turning the emergency stop switch off and then on again will reset the smart system if a system fault has occurred and the machine has shut down.
2. **Membrane Switch Panel** - The function switches at the platform control station are an integral part of a membrane switch panel, which contains switches for drive, high drive, lift, powered deck extension (if equipped), and posi-trac, plus a red tilt indicator light (if equipped). The drive, lift and powered deck extension function switches have a small green light indicator beside them which is illuminated when that function is active. The function switch light indicators will flash once or twice, then go out, when the platform emergency stop switch is turned on. If the light indicators fail to flash or if they fail to stop flashing, re-cycle the emergency stop switch. To activate the drive, lift, and powered deck functions, press the applicable function switch, then activate the joystick within three seconds to operate the function. If the joystick is not activated within three seconds, power is turned off to the function switch and the switch must be pressed again. The posi-trac and high drive functions are used in conjunction with the drive function. Do not try to operate the drive, lift, and powered deck extension functions simultaneously. If the drive, lift, and powered deck extension functions are selected simultaneously, no function will operate. If this occurs, pause, then press only one of the function switches to activate the function. Refer to the following paragraphs for more information about the function switches.
3. **Controller (Joystick)** - The joystick controls three functions: speed, direction, and powered deck extension (if equipped). The joystick is used in conjunction with the trigger switch and controls the drive, high drive, lift, and powered deck extension switches to control speed and direction for the selected function. The drive, high drive and posi-trac functions may be operated simultaneously, but the drive, lift, and powered deck extension functions must be operated independently of each other. If the drive, lift, and powered deck extension functions are selected simultaneously, no function will operate. If this occurs, pause, then press only one of the function switches to activate the function. To operate the joystick, squeeze the red trigger switch, then position the joystick to forward or reverse, as desired.
5. **Steer Switch** - The thumb-operated steer switch, located on top of the joystick, works in conjunction with the trigger switch and activates the steer wheels in the direction the switch is moved (left or right).
6. **Drive Switch** - The drive switch, when used in conjunction with the joystick, provides for driving the machine in forward or reverse. Drive is activated by pressing the drive switch, in conjunction with the trigger switch, and moving the joystick forward (forward) or backward (reverse). Drive speed is determined by the distance the joystick is moved forward or backward. Increased drive speed is possible when the high drive speed switch is pressed either simultaneously with the drive switch or while operating the drive function. The drive switch is part of the enable circuit, which provides power to the joystick and the drive function for 3 seconds when the drive switch is pressed. If the joystick is not activated within 3 seconds, the drive switch must be pressed again before activating the joystick. When the joystick is returned to the center off position, the operator has 3 seconds to re-activate the joystick or select another function before power is removed by the enable circuit. In addition, the posi-trac switch can be engaged while operating the drive function to give a more evenly distributed oil flow to each drive motor. Do not try to operate the drive, lift, and powered deck extension functions simultaneously. If the drive, lift, and powered deck extension functions are selected simultaneously, no function will operate. If this occurs, pause, then press only one of the function switches to activate the function.

**NOTE:** *The machine is equipped with a Pothole Protection System which lowers automatically when the platform is raised. If the Pothole Protection System does not fully lower, the DRIVE function is cut out until the platform is completely lowered.*

7. **High Drive Speed Switch** - The high drive speed switch, when used in conjunction with the joystick being operated in the drive mode, provides additional oil flow to the drive circuit for increased travel speed. To operate high drive, depress the high drive speed switch either simultaneously with the drive switch or while operating the drive function.

### **⚠ CAUTION**

DO NOT USE HIGH DRIVE SPEED WHEN DRIVING IN CLOSE QUARTERS OR WHEN DRIVING IN REVERSE.

### **⚠ CAUTION**

IF HIGH DRIVE IS SELECTED WHEN OIL TEMPERATURE IS VERY COLD (BELOW 4°C 40° F.) HIGH DRIVE WILL NOT ENGAGE IMMEDIATELY. AS OIL WARMS (ABOVE 4°C 40° F.) IF HIGH DRIVE IS SELECTED, IT WILL ENGAGE AUTOMATICALLY WHILE DRIVING.

**NOTE:** *The High Drive Speed switch will cut-out when the platform is raised above the stowed position, returning drive speed to low until the platform is lowered completely.*

### **⚠ CAUTION**

DO NOT OPERATE MACHINE IF HIGH DRIVE SPEED OPERATES WHEN PLATFORM IS RAISED ABOVE THE STOWED POSITION.

8. **Lift Switch** - The lift switch, when used in conjunction with the joystick, provides for raising and lowering the platform. Lift is activated by pressing the lift switch and moving the joystick forward (lift up) or backward (lift down). Lift up speed is determined by the distance the joystick is moved forward. Lift down speed is non-adjustable, and lift down is attained by moving the joystick fully backward. The lift switch is part of the enable circuit, which provides power to the joystick and the lift function for 3 seconds when the lift switch is pressed. If the joystick is not activated within 3 seconds, the lift switch must be pressed again before activating the joystick. When the joystick is returned to the center off position, the operator has 3 seconds to re-activate the joystick or select another function before power is removed by the enable circuit. Do not try to operate the drive, lift, and powered deck extension functions simultaneously. If the drive, lift, and powered deck extension functions are selected simultaneously, no function will operate. If this occurs, pause, then press only one of the function switches to activate the function.

### **⚠ CAUTION**

DO NOT LIFT DOWN WITHOUT COMPLETELY RETRACTING THE PLATFORM EXTENSION.

### **⚠ IMPORTANT**

DO NOT ATTEMPT TO OPERATE THE LIFT AND DRIVE FUNCTIONS AT THE SAME TIME; NO FUNCTION WILL OPERATE AND IT WILL BE NECESSARY TO RE-SELECT A SINGLE FUNCTION. WHEN OPERATING LIFT DOWN MOVE THE JOYSTICK TO THE FULL DOWN (FULLY BACKWARD) POSITION.

9. **Positive Traction (Posi-Trac) Switch** - This switch, when pressed, activates a solenoid on the main control valve, forcing oil through a flow divider in the drive circuit, maintaining hydraulic oil flow to both drive motors for improved traction. The positive traction (Posi-trac) switch activates the positive traction solenoid for a preset time when the positive traction (Posi-trac) switch is pressed. Positive traction is automatically de-activated after the preset time is out. This function will only operate when the drive function is activated.
10. **Tilt Alarm Warning Horn (If Equipped)** - The Tilt Alarm Warning Horn is activated by the Tilt Alarm Switch when the chassis is on a slope. (See Figure 3-1, Tilt for the appropriate degree of tilt). When the machine is equipped with a powered deck extension, the horn is activated when the deck extension is being extended or retracted.

### **⚠ CAUTION**

IF TILT ALARM IS ON WHEN PLATFORM IS RAISED, LOWER PLATFORM COMPLETELY, THEN REPOSITION MACHINE SO THAT IT IS LEVEL BEFORE RAISING PLATFORM.

11. **Tilt Alarm Warning Light (Red) (If Equipped)** - A warning light on the membrane switch panel that illuminates when the chassis is on a severe slope (See Figure 3-1, Tilt for the appropriate degree of tilt).
12. **Horn (If Equipped)** - This push-button switch, when activated, permits the operator to warn jobsite personnel when the machine is operating in the area.
13. **Battery Discharge Indicator (If Equipped)** - The battery discharge indicator is a gauge that provides a visual indication of the condition of the batteries.

**SECTION 3 - USER RESPONSIBILITIES AND MACHINE CONTROL**

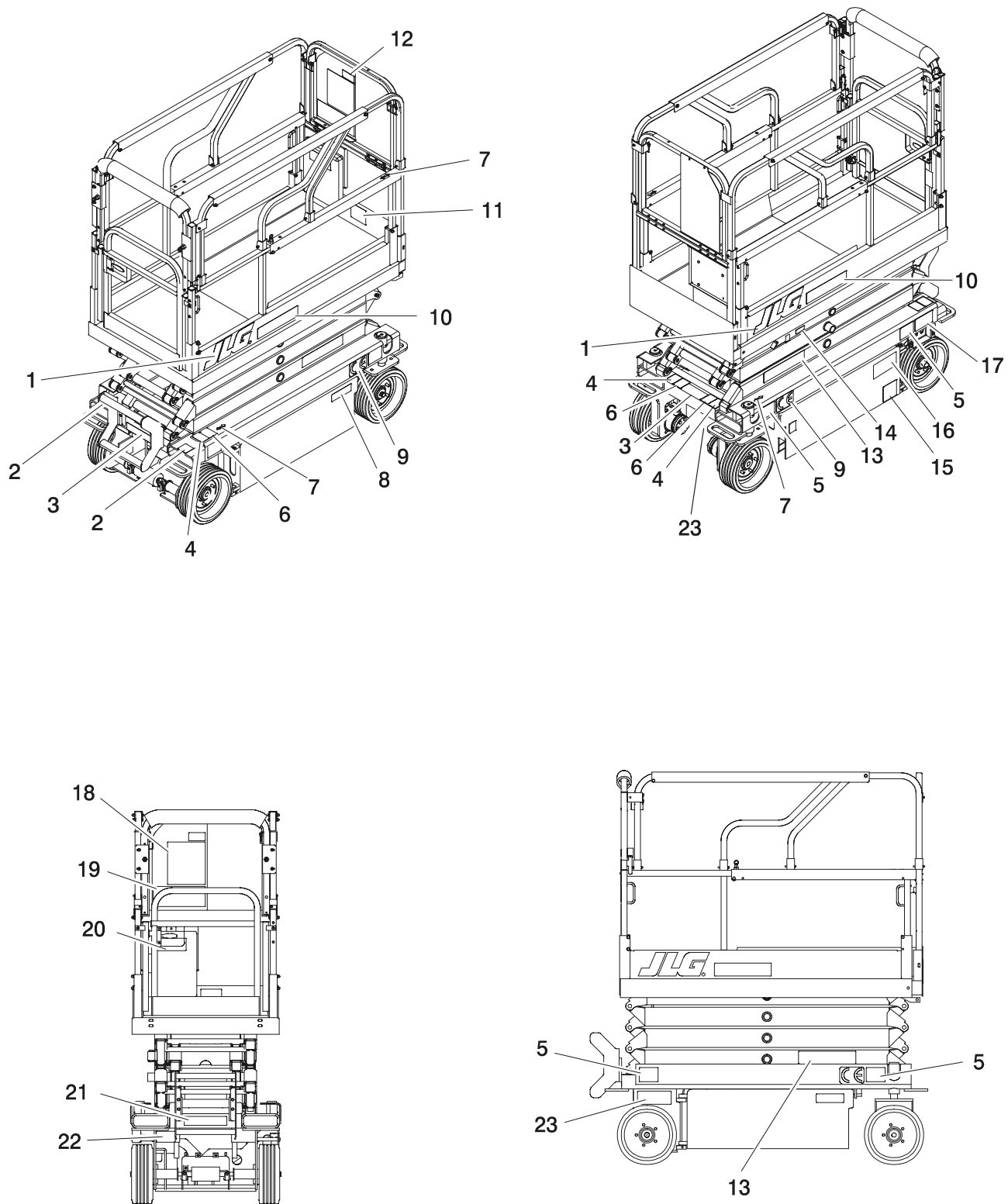

**Figure 3-4. Decal Location (1932E2)**

## SECTION 3 - USER RESPONSIBILITIES AND MACHINE CONTROL

**Table 3-2. Decal Location Legend - 1932E2**

Item # 1532E2/ 1932E2	Ansi	Australian	China/ English	Dutch	French	French/ English	German	Italian	Japan
1	1702773	1702773	1702773	1702773	1702773	1702773	1702773	1702773	1702773
2	1703817	1703817	1703817	1703817	1703817	1703817	1703817	1703817	1703817
3	1703823	1703823	1704609	1703895	1703866	1703866	1703883	1703888	1703850
4	1703811	1703811	1703811	1703811	1703811	1703811	1703811	1703811	1703811
5	1704399	1704399	1704399	1704399	1704399	1704399	1704399	1704399	1704399
6	1703814	1703814	1703814	1703814	1703814	1703814	1703814	1703814	1703814
7	1703819	1703819	1703819	1703819	1703819	1703819	1703819	1703819	1703819
8	1703813	1703813	1704613	1703893	1703864	1703864	1703881	1703886	1703848
9	N/A	N/A	N/A	1702928	1702928	N/A	1702928	1702928	N/A
10	3252747 (1532E2) 3252598 (1932E2)	N/A (1532E2) 3252598 (1932E2)	3252747 (1532E2) 3252598 (1932E2)	N/A (1532E2) 3252598 (1932E2)	3252747 (1532E2) 3252598 (1932E2)	3252747 (1532E2) 3252598 (1932E2)	N/A (1532E2) 3252598 (1932E2)	N/A (1532E2) 3252598 (1932E2)	3252747 (1532E2) 3252598 (1932E2)
11	3251813	N/A	N/A	3251813	N/A	3251813	N/A	N/A	N/A
12	N/A	1703969	N/A	1703973	1703970	1703868	1703971	1703972	N/A
13	1703818	1703818	1704611	1703894	1703865	1703865	1703882	1703887	1704282
14	1703869	1703869	1703869	1703869	1703869	1703869	1703869	1703869	1703869
15	1702153	1704123	1704607	N/A	N/A	1703074	N/A	N/A	1701621
16	1703868	N/A	1703868	N/A	N/A	1703868	N/A	1703886	1703868
17	1703706	1703706	1703706	1703706	1703706	1703706	1703706	1703706	1703706
18	1703816	3252616	1704616	1704173	1704173	1703867	1704173	1704173	1704278 (1532E2) 1703868 (1932E2)
19	N/A	1703877	N/A	1703896	1703878	N/A	1703884	1703889	1704807
20	1701509	1701509	1701509	1701509	1701509	1701509	1701509	1701509	1701509
21	1704017	1704017	1704608	1704149	1704146	1704146	1704147	1704148	1704144
22	1703822	1703822	1703822	1703822	1703822	1703822	1703822	1703822	1703822
23	3252645	3252534	3252699	3252533	3252645 (1532E2) 3252533 (1932E2)	3252645	3252533	3252533	3252644 (1532E2) 3252749 (1932E2)

## SECTION 3 - USER RESPONSIBILITIES AND MACHINE CONTROL

**Table 3-3. Decal Location Legend - 1932E2 (continued)**

Item # 1532E2/ 1932E2	Korean	Brazil	Spanish	Latin	CE/English
1	1702773	1702773	1702773	1702773	1702773
2	1703817	1703817	1703817	1703817	1703817
3	1703858	1703834	1703842	1703842	1703823
4	1703811	1703811	1703811	1703811	1703811
5	1704399	1704399	1704399	1704399	1704399
6	1703814	1703814	1703814	1703814	1703814
7	1703819	1703819	1703819	1703819	1703819
8	1703856	1703832	1703840	1703840	1703813
9	N/A	N/A	1702928	N/A	1702928
10	3252747 (1532E2) 3252598 (1932E2)	3252747 (1532E2) 3252598 (1932E2)	N/A (1532E2) 3252598 (1932E2)	3252747 (1532E2) 3252598 (1932E2)	3252747 (1532E2) 3252598 (1932E2)
11	N/A	3251813	N/A	3251813	N/A
12	N/A	1703829	1703974	1703837	1703969
13	1703857	1703865	1703841	1703841	1703818
14	1703869	1703869	1703869	1703869	1703869
15	1703962	1703961	N/A	1702552	N/A
16	1703868	1703868	N/A	1703868	N/A
17	1703706	1703706	1703706	1703706	1703706
18	1703859	1703835	1704173	1703843	1704173
19	1703868	1703868	1703897	1703868	1703877
20	1701509	1701509	1701509	1701509	1701509
21	1704145	1704142	1704143	1704143	1704017
22	1703822	1703822	1703822	1703822	1703822
23	3252645	3252645	3252533	3252645	3252533

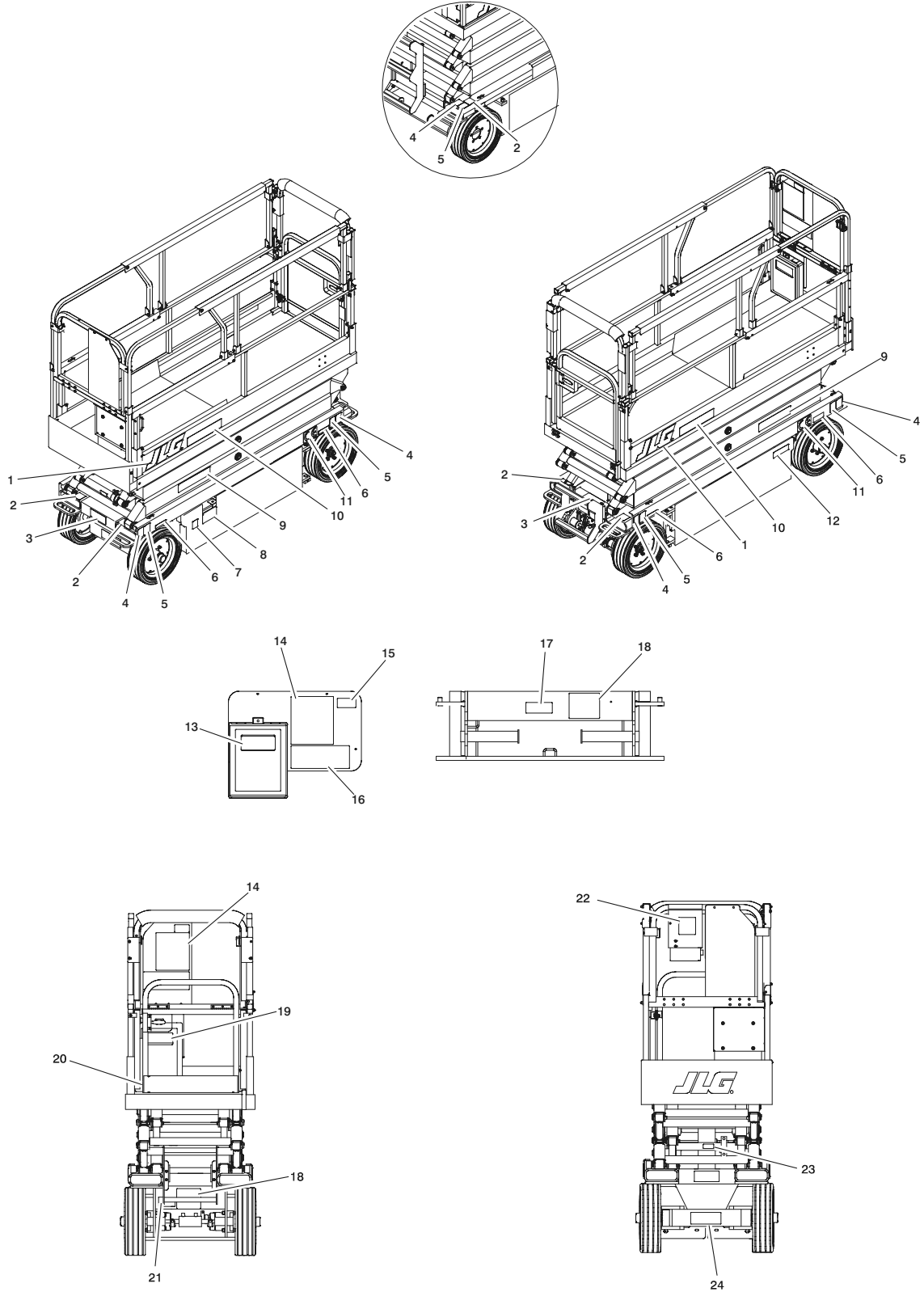

Figure 3-5. Decal Location - 2032E2/2632E2/2646E2

## SECTION 3 - USER RESPONSIBILITIES AND MACHINE CONTROL

Table 3-4. Decal Location Legend - 2032E2/2632E2/2646E2

Item # 2032E2 2632E2 2646E2	Ansi	Australian	China/ English	Dutch	CSA/French	Spanish	German	Italian	Japan
1	1702773	1702773	1702773	1702773	1702773	1702773	1702773	1702773	1702773
2	1703817	1703817	1703817	1703817	1703817	1703817	1703817	1703817	1703817
3	1703823	1703823	1704069	1703895	1703866	1703842	1703883	1703888	1703850
4	1703811	1703811	1703811	1703811	1703811	1703811	1703811	1703811	1703811
5	1703814	1703814	1703814	1703814	1703814	1703814	1703814	1703814	1703814
6	1704400 (2032E2) 1704137 (2632E2) 1704402 (2646E2)	1704400 (2032E2) 1704137 (2632E2) 1704402 (2646E2)	1704400 (2032E2) N/A (2632E2) 1704402 (2646E2)	1704400 (2032E2) N/A (2632E2) 1704402 (2646E2)	1704400 (2032E2) 1704137 (2632E2) 1704402 (2646E2)	1704400 (2032E2) N/A (2632E2) 1704402 (2646E2)	1704400 (2032E2) N/A (2632E2) 1704402 (2646E2)	1704400 (2032E2) N/A (2632E2) 1704402 (2646E2)	1704400 (2032E2) 1704137 (2632E2) 1704402 (2646E2)
7	1703812	1703812	1703812	1703812	1703812	1703812	1703812	1703812	1703812
8	1703706	1703706	1703706	1703706	1703706	1703706	1703706	1703706	1703706
9	1703818	1703818	1704611	1703894	1703865	1703841	1703882	1703887	1704282
10	3252567 (2032E2) 1705013 (2632E2) 3252568 (2646E2)	3252567 (2032E2) 1705013 (2632E2) 3252568 (2646E2)	3252567 (2032E2) N/A (2632E2) 3252568 (2646E2)	3252567 (2032E2) N/A (2632E2) 3252568 (2646E2)	3252567 (2032E2) 1705013 (2632E2) 3252568 (2646E2)	3252567 (2032E2) N/A (2632E2) 3252568 (2646E2)	3252567 (2032E2) N/A (2632E2) 3252568 (2646E2)	3252567 (2032E2) N/A (2632E2) 3252568 (2646E2)	3252567 (2032E2) 1705013 (2632E2) 3252568 (2646E2)
11	N/A	N/A	N/A	1702928	N/A	1702928	1702928	1702928	N/A
12	1703813	1703813	1704613	1703893	1703864	1703840	1703881	1703886	1703848
13	1701509	1701509	1701509	1701509	1701509	1701509	1701509	1701509	1701509
14	1703816	1704115	1704616	1703898	1703867	1703898	1703898	1703898	1704807
15	1703821	1703969	1704610	1703973	1703861	1703874	1703971	1703972	1703845
16	1703694	1703877	1703694	1703896	1703694	1703897	1703884	1703889	1704283 (2032E2/ 2646E2) 1703868 (2632E2)
17	1704420 (2632E2 only)	1704420 (2632E2 only)	1704420 (2632E2 only)	1704420 (2632E2 only)	1704420 (2632E2 only)	1704420 (2632E2 only)	1704420 (2632E2 only)	1704420 (2632E2 only)	1704420 (2632E2 only)
18	1703698	1703698	1703614	1703892	N/A	1703839	1703880	1703885	1704281
19	1703822 (2032E2 only)	1703822 (2032E2 only)	1703822 (2032E2 only)	1703822 (2032E2 only)	1703822 (2032E2 only)	1703822 (2032E2 only)	1703822 (2032E2 only)	1703822 (2032E2 only)	1703822 (2032E2 only)
20	1703621	1703621	1703621	1703621	1703621	1703621	1703621	1703621	1703621
21	1703697	1703697	1703697	1703697	1703697	1703697	1703697	1703697	1703697
22	3252645	3252534	3252699	3252565	3252564	3252565	3252565	3252565	3252749
23	N/A	1704123	1703694	N/A	1703694	N/A	N/A	N/A	1704283
24	N/A	1702153	1704607	N/A	1703074	N/A	N/A	N/A	1701621

## SECTION 3 - USER RESPONSIBILITIES AND MACHINE CONTROL

**Table 3-5. Decal Location Legend - 2032E2/2632E2/2646E2 (continued)**

Item # 2032E2 2632E2 2646E2	Latin	CE/English	CE/French	Brazil	Korean
1	1702773	1702773	1702773	1702773	1702773
2	1703817	1703817	1703817	1703817	1703817
3	1703842	170383	1703866	1703834	1703858
4	1703811	1703811	1703811	1703811	1703811
5	1703814	1703814	1703814	1703814	1703814
6	1704400 (2032E2) 1704137 (2632E2) 1704402 (2646E2)	1704400 (2032E2) N/A (2632E2) 1704402 (2646E2)	1704400 (2032E2) N/A (2632E2) 1704402 (2646E2)	1704400 (2032E2) 1704137 (2632E2) 1704402 (2646E2)	1704400 (2032E2) 1704137 (2632E2) 1704402 (2646E2)
7	1703812	1703812	1703812	1703812	1703812
8	1703706	1703706	1703706	1703706	1703706
9	1703841	1703818	1703865	1703833	1703857
10	3252567 (2032E2) 1705013 (2632E2) 3252568 (2646E2)	3252567 (2032E2) N/A (2632E2) 3252568 (2646E2)	3252567 (2032E2) N/A (2632E2) 3252568 (2646E2)	3252567 (2032E2) 1705013 (2632E2) 3252568 (2646E2)	3252567 (2032E2) 1705013 (2632E2) 3252568 (2646E2)
11	N/A	1702928	1702928	1702928	N/A
12	1703840	1703813	1703864	1703832	1703856
13	1701509	1701509	1701509	1701509	1701509
14	1703843	1703898	1703898	1703835	1703859
15	1703837	1703969	1703970	1703829	1703853
16	1703694	1703877	1703868	1703694	1703694
17	1704420 (2632E2 only)	1704420 (2632E2 only)	1704420 (2632E2 only)	1704420 (2632E2 only)	1704420 (2632E2 only)
18	1703839	1703698	1703822	1703831	1703855
19	1703822 (2032E2 only)	1703822 (2032E2 only)	1703822 (2032E2 only)	1703822 (2032E2 only)	1703822 (2032E2 only)
20	1702631	1702631	1702631	1703621	1703621
21	1703697	1703697	1703697	1703697	1703697
22	3252645	3252565	3252565	3252645	3252645
23	1703694	N/A	N/A	1703694	1703694
24	1702552	N/A	N/A	1703691	1703962

## SECTION 3 - USER RESPONSIBILITIES AND MACHINE CONTROL

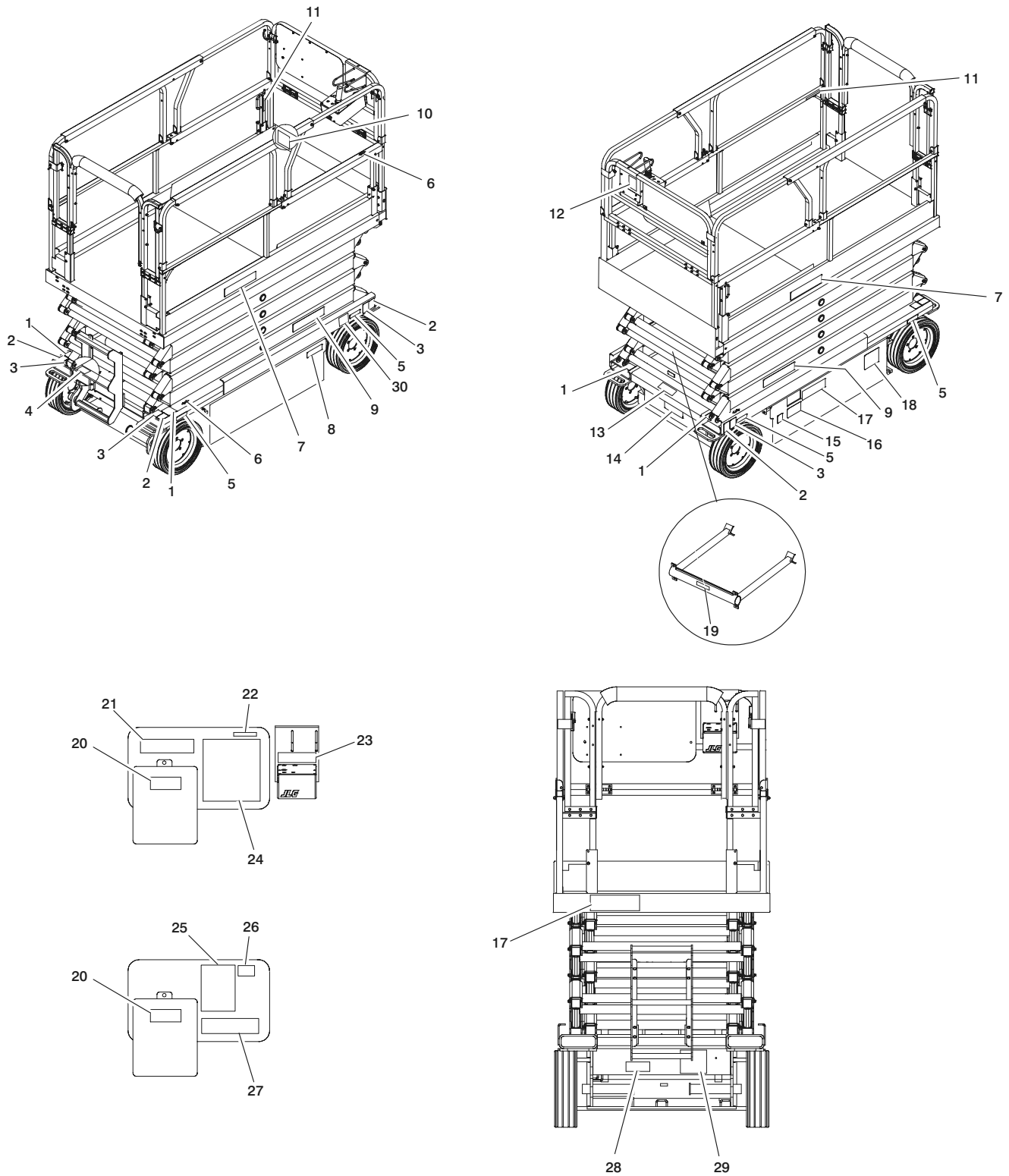

Figure 3-6. Decal Location - 3246E2

## SECTION 3 - USER RESPONSIBILITIES AND MACHINE CONTROL

**Table 3-6. Decal Location Legend - 3246E2**

Item # 3246E2	Ansi	Latin	Japan	CSA/French	CE/Spanish	CE/English	CE/French	German	Italian
1	1703817	1703817	1703817	1703817	1703817	1703817	1703817	1703817	1703817
2	1703811	1703811	1703811	1703811	1703811	1703811	1703811	1703811	1703811
3	1703814	1703814	1703814	1703814	1703814	1703814	1703814	1703814	1703814
4	1703823	1703842	1703850	1703866	1703842	1703823	1703866	1703883	1703888
5	1704403	1704403	1704403	1704403	1704403	1704403	1704403	1704403	1704403
6	1703819	1703819	1703819	1703819	1703819	1703819	1703819	1703819	1703819
7	3252619	3252619	3252619	3252619	3252619	3252619	3252619	3252619	3252619
8	1703813	1703840	1703848	1703864	1703840	1703813	1703864	1703881	1703886
9	1703818	1703841	1704282	1703865	1703841	1703818	1703865	1703882	1703887
10	3251813	3251813	N/A	3251813	N/A	N/A	N/A	N/A	N/A
11	1704277	1704277	1704277	1704277	1704277	1704277	1704277	1704277	1704277
12	1702631	1702631	1702631	1702631	1702631	1702631	1702631	1702631	1702631
13	1703823	1703842	1703850	1703866	1703842	1703823	1703866	1703883	1703888
14	3252645	3252645	3252749	3252645	3252565	3252565	3252565	3252565	3252565
15	1703812	1703812	1703812	1703812	1703812	1703812	1703812	1703812	1703812
16	1703706	1703706	1703706	1703706	1703706	1703706	1703706	1703706	1703706
17	1704201	1704201	1704282	1704201	N/A	N/A	N/A	N/A	N/A
18	1702153	1702552	1701621	1703064	N/A	N/A	N/A	N/A	N/A
19	1703697	1703697	1703697	1703697	1703697	1703697	1703697	1703697	1703697
20	1701509	1701509	1701509	1701509	1701509	1701509	1701509	1701509	1701509
21	1704201	1704201	1704201	1704201	N/A	N/A	N/A	N/A	N/A
22	1703821	1703837	1703845	1703861	N/A	N/A	N/A	N/A	N/A
23	1703695	1703838	1704280	1703862	N/A	N/A	N/A	N/A	N/A
24	1703816	1703843	1704807	1703867	N/A	N/A	N/A	N/A	N/A
25	N/A	N/A	N/A	N/A	1704202	1704202	1704202	1704202	1704202
26	N/A	N/A	N/A	N/A	1703974	1703969	1703970	1703971	1703972
27	N/A	N/A	N/A	N/A	1703897	1703877	1703878	1703884	1703889
28	1704420	1704420	1704420	1704420	1704420	1704420	1704420	1704420	1704420
29	1703698	1703839	1704281	1703863	1703839	1703698	1703863	1703880	1703885
30	N/A	N/A	N/A	N/A	1702928	N/A	1702928	N/A	N/A

## SECTION 3 - USER RESPONSIBILITIES AND MACHINE CONTROL

Table 3-7. Decal Location Legend - 3246E2 (continued)

Item # 3246E2	Australian	Brazil	Korean	China	Dutch
1	1703817	1703817	1703817	1703817	1703817
2	1703811	1703811	1703811	1703811	1703811
3	1703814	1703814	1703814	1703814	1703814
4	1703823	1703834	1703858	1704609	1703895
5	1704403	1704403	1704403	1704403	1704403
6	1703819	1703819	1703819	1703819	1703819
7	3252619	3252619	3252619	3252619	3252619
8	1703813	1703832	1703856	1704613	1703893
9	1703818	1703833	1703857	1704611	1703894
10	N/A	3251813	N/A	3251813	N/A
11	1704277	1704277	1704277	1704277	1704277
12	1702631	1702631	1702631	1702631	1702631
13	1703823	1703834	1703858	1704609	1703895
14	3252534	3252645	3252645	3252699	3252565
15	1703812	1703812	1703812	1703812	1703812
16	1703706	1703706	1703706	1703706	1703706
17	1704133	1704201	1704201	1704201	N/A
18	1702153	1703961	1703962	1704607	N/A
19	1703697	1703697	1703697	1703697	1703697
20	1701509	1701509	1701509	1701509	1701509
21	N/A	1704201	1704201	1704201	N/A
22	N/A	1703820	1703853	1704610	N/A
23	N/A	1703830	1703854	1704615	N/A
24	N/A	1703835	1703859	1704616	N/A
25	1704203	N/A	N/A	N/A	1704202
26	1703969	N/A	N/A	N/A	1703973
27	1703877	N/A	N/A	N/A	1703896
28	1704420	1704420	1704420	1704420	1704420
29	1703698	1703831	1703855	1704614	1703892
30	N/A	N/A	N/A	N/A	1702928

## SECTION 4. MACHINE OPERATION

### 4.1 DESCRIPTION

This machine is a self-propelled hydraulic lift equipped with a work platform on an elevating scissor mechanism. Vibrations emitted by these machines are not hazardous to an operator in the work platform. The equivalent continuous A-Weighted sound pressure level at the work platform is less than 70 dB(A).

The primary operator control station is in the platform. From this control station, the operator can drive and steer the machine in both forward and reverse directions. The machine has a Ground Control Station which will override the Platform Control Station. Ground Controls operate lift and lower and are to be used in an emergency to lower the platform to the ground should the operator in the platform be unable to do so. Ground Control is also to be used in Pre-Start Inspection.

**Table 4-1. Operating Specifications (CE and Australian)**

MODEL	1932E2	2032E2	2632E2 (Aust Only)	2646E2	3246E2
Maximum Work Load (Capacity) Extension Only:	230 kg 120 kg	340 kg 120 kg	230 kg 120 kg	340 kg 120 kg	320 kg 120 kg
Maximum Occupants	2 persons + 70 kg	2 persons + 180 kg	2 persons + 70 kg	2 persons + 180 kg	2 persons + 155 kg
Extension Only	1 person + 40kg	1 person + 40kg	1 person + 40kg	1 person + 40kg	1 person + 40kg
Maximum Travel Grade (Gradeability)	20% / 11.3°	25% / 14°	20% / 11.3°	25% / 14°	25% / 14°
Maximum Travel Grade (Sideslope)	1.5°	1.5°	2°	2°	2°
Maximum Platform Height	5.8 m	6.1 m	7.9 m	7.9 m	9.75 m
Maximum Tire Load	Reference Decal on Machine				
Maximum Travel Speed	4.0 kmh	4.2 kmh	3.6 kmh	3.6 kmh	3.6 kmh
Maximum Allowable Wind Speed (CE)	12.5 m/s	12.5 m/s	N/A	12.5 m/s	12.5 m/s
Maximum Allowable Wind Speed (Aust)	8 m/s	8 m/s	8 m/s	8 m/s	8 m/s
Maximum Manual Force	450 N	500 N	450N	500 N	465 N
Inside Turning Radius	0.5 m	1.0 m	1.0 m	1.0 m	1.1 m
Maximum Hydraulic System Pressure	207 Bar				
Electrical System Voltage	24 Volt				
Gross Machine Weight (Platform Empty)	1360 kg	2091 kg	2415 kg	2086 kg	2804kg

### 4.2 GENERAL

This section provides the necessary information needed to operate the machine. Included in this section are the procedures for starting, stopping, traveling, steering, parking, platform loading and transporting the machine. It is important that the user read and understand the proper procedures before operating the machine.

### 4.3 MOTOR OPERATION

#### Power Selector Switch

The power selector switch functions to direct battery power to the desired control station. With the switch in the ground position, battery power is supplied to the emergency stop switch at the ground control station. When the switch is in the platform position, battery power is supplied to the emergency stop switch at the platform control station. The power selector switch should be in the off position when recharging the batteries and/or parking the machine overnight.

#### Emergency Stop Switch

This switch, when in the on (out) position, provides battery power to the ground controls or platform controls, as applicable. In addition, the switch can be used to turn off power (push the switch in) to the function controls in the event of an emergency.

#### Motor Activation

With the power selector switch in the appropriate position (platform or ground) and the applicable emergency stop switch in the on position and a function switch or controller is operated and held, the motor becomes activated and operates the desired function. When operating from the ground controls, the power selector switch must be held in the ground position while the function is being operated. When operating the platform controls, the lift switch must be used in conjunction with the enable switch, to drive the lever must be depressed in conjunction with the joystick travel.

#### **⚠ IMPORTANT**

**IF A MOTOR MALFUNCTION NECESSITATES UNSCHEDULED SHUTDOWN, DETERMINE AND CORRECT CAUSE BEFORE RESUMING ANY OPERATION.**

#### **⚠ IMPORTANT**

**ALWAYS POSITION POWER SELECTOR AND EMERGENCY STOP SWITCHES TO THE 'OFF' POSITION WHEN MACHINE IS NOT IN USE.**

### 4.4 RAISING AND LOWERING (LIFTING)

#### **⚠ WARNING**

**DO NOT RAISE PLATFORM EXCEPT ON A HARD, LEVEL SURFACE FREE OF OBSTRUCTIONS AND HOLES.**

**NOTE:** *The lift switch will not operate if the red trigger switch on the joystick is depressed.*

#### Raising

1. If the machine is shut down, place the power selector switch to the desired position (platform or ground).
2. Position the applicable emergency stop switch to the on position.
3. If operating from the ground controls, position the lift switch to up and hold until desired elevation is achieved. If operating from the platform controls, press and hold the enable switch, move the lift switch forward (up) and hold until desired elevation is reached. The lift switch works in conjunction with the enable switch.

#### Lowering

#### **⚠ WARNING**

**ENSURE SCISSOR ARM AREA IS FREE OF PERSONNEL PRIOR TO LOWERING PLATFORM.**

If operating from the ground controls, position the lift switch to down and hold until desired elevation is achieved or until platform is fully lowered. If operating from the platform controls, press the enable switch and push the lift switch backward (down) and hold until desired elevation is reached or until platform is fully lowered. The lift switch works in conjunction with the enable switch.

#### **⚠ WARNING**

**DO NOT 'LIFT DOWN' WITHOUT COMPLETELY RETRACTING THE PLATFORM EXTENSION.**

**4.5 PLATFORM EXTENSION**

**Manual Platform Extension**

The machine is equipped with a mechanically extendible deck, which adds 0.9 m (3 ft.) to the front of the platform, giving the operator better access to worksites. To extend the deck, pull pins, attached to lanyards, located at both sides at the front of the platform extension, extend platform extension and replace pins in holes. Do not drive machine unless platform extension is properly pinned. To retract the deck, remove pins pull platform extension back in and install pins back into holes. Do not drive machine unless platform extension is properly pinned. Maximum capacity of the deck extension is 120 kg (250 lb) - 1 person.

**4.6 STEERING**

To steer the machine, the thumb operated steer control switch on the joystick is positioned to the right for traveling right, or to the left for traveling left. When released, the switch will return to the center-off position and the wheels will remain in the previously selected position. To return the wheels to the straightened position, the switch must be activated in the opposite direction until the wheels are centered.

**4.7 TRAVELING (DRIVING)**

**NOTE:** High drive is cut out when the platform is raised above the preset heights listed in Figure 4-2, High Drive Cutout:

Table 4-2. High Drive Cutout

Model	High Drive Cutout (Maximum Height)
1932E2	104 in (2.6 m)
2032E2	84 in (2.1 m)
2632E2 (Australian Only)	114 in (2.9 m)
2632E2/2646E2	102 in (2.6 m)
3246E2	112 in (2.8 m)

**⚠ WARNING**

**DO NOT DRIVE WITH PLATFORM RAISED EXCEPT ON A SMOOTH, FIRM AND LEVEL SURFACE FREE OF OBSTRUCTIONS AND HOLES.**

**⚠ WARNING**

**TO AVOID LOSS OF TRAVEL CONTROL OR UPSET ON GRADES AND SIDESLOPES, DO NOT DRIVE MACHINE ON GRADES OR SIDESLOPES EXCEEDING THOSE SPECIFIED FOR THE MACHINE.**

**⚠ WARNING**

**TRAVEL GRADES IN "LOW" DRIVE SPEED ONLY. USE EXTREME CAUTION WHEN DRIVING IN REVERSE AND AT ALL TIMES WHEN DRIVING WITH PLATFORM ELEVATED AND ESPECIALLY WHEN DRIVING WITH ANY PART OF MACHINE WITHIN 1.8 METERS (6 FT) OF AN OBSTRUCTION. TO GO BACK DOWN THE GRADE, IF TRAVELING FORWARD UP THE GRADE, BUMP THE CONTROL HANDLE FORWARD SLIGHTLY TO ENSURE THE BRAKES ARE RELEASED BEFORE DESCENDING THE GRADE.**

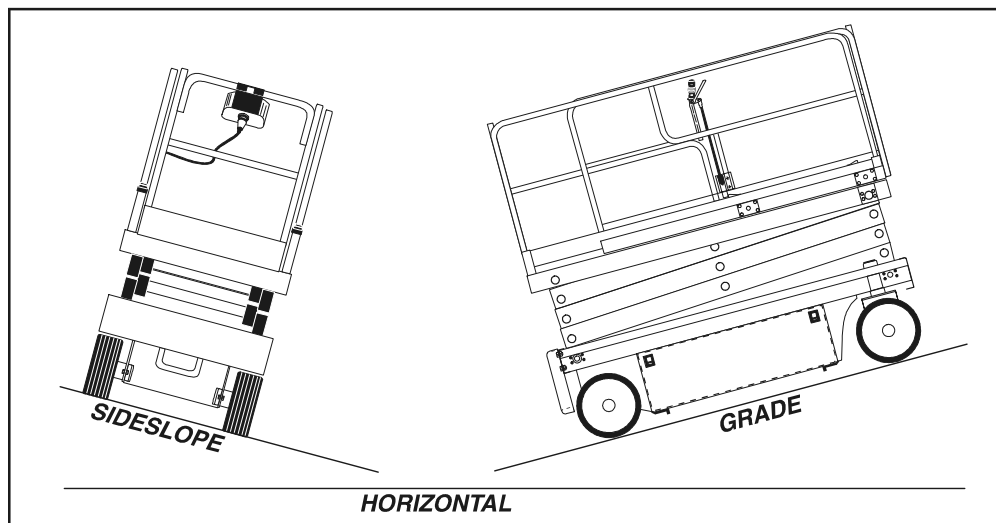

Figure 4-1. Grade and Sideslope

## SECTION 4 - MACHINE OPERATION

---

### WARNING

**MAKE SURE DECK EXTENSION IS LOCKED IN PLACE BEFORE DRIVING MACHINE.**

**NOTE:** *The machine is equipped with a Pothole Protection System which lowers automatically when the platform is raised or a door is opened. If the pothole protection does not fully lower, the drive function is cut out until the platform is completely lowered.*

**NOTE:** *When the machine is raised, and a door is opened, the machine will not drive.*

### Traveling Forward

---

1. Place power selector switch at ground control station to platform.
2. Position emergency stop switch at platform control station to on position.
3. Using the speed select switch, select low or high speed.
4. Squeeze controller (joystick), depressing red trigger on front of joystick, and move joystick forward for duration of travel. For additional drive speed, push the joystick completely forward, this will run the machine in high drive.

### IMPORTANT

**WHEN TRAVELING A GRADE, MAXIMUM TRACTION IS OBTAINED BY TRAVELING IN REVERSE ON 1932E2. REVERSE TRAVEL SHOULD BE USED WHEN LOADING ON A TRUCK OR WHEN ADEQUATE TRACTION IS NOT ACHIEVED BY TRAVELING FORWARD.**

### Traveling in Reverse

---

5. Position power selector switch at ground control station to platform.
6. Position emergency stop switch at platform control station to on position.
7. Squeeze joystick, depressing red trigger on front of joystick, and move joystick backward (reverse) for duration of travel. For additional drive speed pull joystick completely back, this will run the machine in high drive. When driving in reverse only use low speed.

### WARNING

**MAKE SURE DECK EXTENSION IS PINNED IN PLACE BEFORE DRIVING MACHINE.**

## 4.8 PARKING AND STOWING

---

**NOTE:** *When parking battery-powered units overnight, batteries should be charged in accordance with instructions in Section 2 to ensure readiness for the following workday.*

### Park and stow machine as follows:

1. Drive machine to a reasonably well-protected and well-ventilated area.
2. Ensure platform is fully lowered.
3. Position emergency stop switch to off position.
4. If necessary, cover the instruction placards, caution and warning decals so that they will be protected from hostile environment.
5. Chock at least two wheels when parking machine for an extended period of time.
6. Turn switch to off and remove key to disable machine from unauthorized use.

**4.9 PLATFORM LOADING**

The platform maximum rated load capacity is shown on a placard located on the platform and the manufactures nameplate located at the front of the machine and is based upon the following criteria.

1. Machine is positioned on a smooth, firm and level surface.
2. All braking devices are engaged.
3. Maximum platform capacity for each model in its standard configuration is as follows:

**Table 4-3. Platform Capacity**

Model	Capacity
1932E2	230 kg
2032E2	340 kg
2632E2	230 kg
2646E2 (Australian Only)	340 kg
3246E2	320 kg

4. Maximum capacity of the manual platform extension is 120 kg - 1 person.

**NOTE:** The weight in the platform should be uniformly distributed in the platform. The total combined weight of personal, tools and supplies must not exceed the above figures.

**4.10 SAFETY PROP**

**⚠ WARNING**

THE SAFETY PROP MUST BE USED WHENEVER MAINTENANCE PERFORMED ON THE MACHINE REQUIRES THE SCISSOR ARMS TO BE RAISED.

To engage the safety prop, raise the platform, then remove the prop from the prop bracket until it hangs vertically. Lower the platform until the safety prop rests on the point provided on the arm. Maintenance can now begin.

To store the safety prop, raise the platform so that the prop can be rotated counterclockwise until it rests on the bracket provided on the scissor arms.

**4.11 TIE DOWN AND LIFTING**

When transporting the machine, the platform extension must be fully retracted and the platform fully lowered in the stowed mode with the machine securely tied down to the truck or trailer deck. There are tie down eyes located at all four corners of the machine for shipping. Refer to Figure 4-2., Lift and Tie Down for specific tie down instructions.

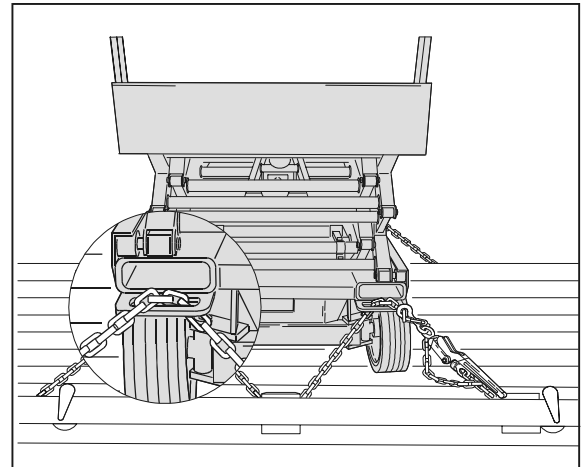

**Figure 4-2. Lift and Tie Down**  
(Front and Rear Typical)

## SECTION 4 - MACHINE OPERATION

### Lifting

If it becomes necessary to lift the machine, it is possible to lift the machine with a forklift. On 2032E2/2632E2/2646E2 and 3246E2 forklift pockets are provided at the front and rear of the machine. The 1932E2 can only be lifted from the rear forklift pockets. It is very important that the forklift operator use only the designated lifting areas to lift the machine.

**NOTE:** Do not lift the machine from the sides.

Forklifts, cranes, or other lifting devices must be capable of handling the following weights:

Model	GVW CE Specifications (Approximate)
1932E2	1360 kg
2032E2	2091 kg
2632E2 (Australian Only)	2415 kg
2646E2	2086 kg
3246E2	2804 kg

### TOWING

It is not recommended that this machine be towed, except in the event of an emergency such as a machine malfunction or a total machine power failure. Refer to Section 6 for emergency towing procedures.

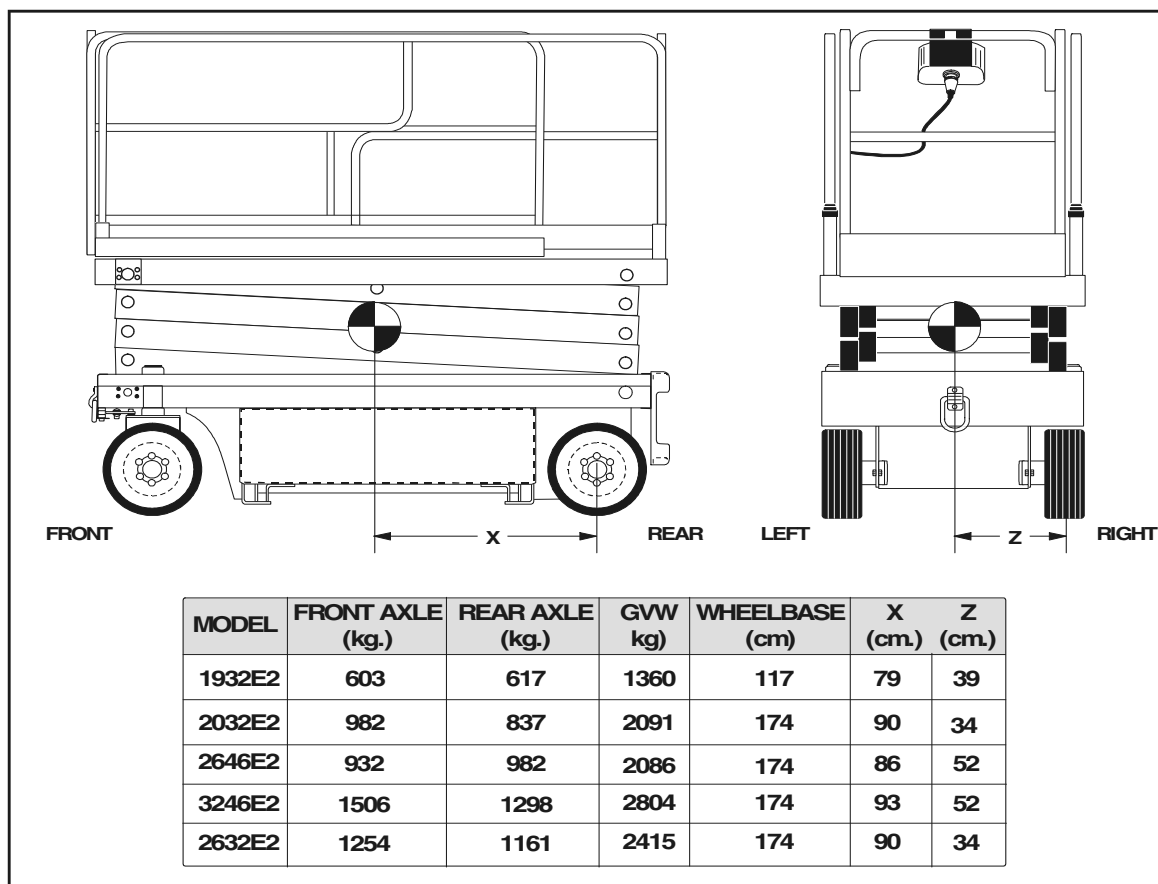

Figure 4-3. Lifting Chart

## SECTION 5. EMERGENCY PROCEDURES

### 5.1 GENERAL

This section provides information on the procedures to be followed and on the systems and controls to be used in the event an emergency situation is encountered during machine operation. Prior to operation of the machine and periodically thereafter, the entire operating manual, including this section, should be reviewed by all personnel whose responsibilities include any work or contact with the machine.

### 5.2 EMERGENCY TOWING PROCEDURES

Although towing the machine is prohibited, provisions for moving the machine, in case of a malfunction, power failure, or for loading on a truck, have been incorporated. The following procedures are to be used **ONLY** for emergency movement to a suitable maintenance area or to load the machine on a truck. These procedures are also found on a decal affixed to the frame at the rear of the machine.

1. Chock the wheels securely.
2. Turn the black knob on the main control valve counterclockwise all the way out to disengage the drive motors.
3. Using a 19mm wrench, release the parking brake by moving the brake cams to the horizontal position.
4. Using suitable equipment for assistance, remove the chocks, and move the machine to an appropriate maintenance area or onto the truck.

**After moving the machine, complete the following procedures:**

1. Position the machine on a firm, level surface.
2. Chock the wheels securely.
3. Using a 19mm wrench, engage the parking brake by moving the brake cams to the vertical position.
4. Turn the black knob on the main control valve clockwise all the way in to engage the drive motors.
5. Remove the chocks from the wheels.

### 5.3 EMERGENCY CONTROLS AND THEIR LOCATIONS

#### Emergency Stop Switch

These large red buttons, one located at the Ground Control Station and one at the Platform Control Station, will immediately stop the machine when depressed.

#### **WARNING**

**CHECK MACHINE DAILY TO MAKE SURE EMERGENCY STOP BUTTON IS IN PLACE AND THAT GROUND CONTROL INSTRUCTIONS ARE IN PLACE AND LEGIBLE.**

#### Power Selector Switch

The key-operated power select switch, located at the Ground Control Station, can also be used to shut down the machine in an emergency situation. To shut off machine power, turn the power select switch to the center off (O) position.

#### Ground Control Station

The Ground Control Station is located on the left side of the machine frame. The controls on this panel provide the means for overriding the platform controls and for controlling the platform lift up and down functions from the ground. Place the power select switch in the ground position and operate the lift switch to lift up or down.

### Manual Descent

---

In the event of total power failure, the manual descent valve is used to lower the platform using gravity. The manual descent control is located at the rear behind the ladder.

- **1932E2/2032E2/2632E2** - These are all equipped with a manual descent handle which opens the valve spool and lowers the platform.
- **2646E2/3246E2 equipped with a manual descent lever** - Pushing the manual descent lever opens the valve spool and lowers the platform.
- **2646E2/3246E2 equipped with a manual descent-pump** - Operate as follows:
  1. Turn knob (clockwise) on lowering valve until fully closed
  2. Install handle, and pump until holding valve opens and desired descent speed is attained.
  3. When platform is fully lowered, turn knob on lowering valve (counterclockwise) to reopen valve and return handle to stowed position.

3. Cranes, forklift trucks or other equipment which may be available are to be used to remove platform occupants and stabilize motion of the machine in case machine controls are inadequate or malfunction when used.

### Platform Caught Overhead

---

If the platform becomes jammed or snagged in overhead structures or equipment, do not continue operation of the machine from either the platform or the ground until the operator and all personnel are safely moved to a secure location. Only then should an attempt be made to free the platform using any necessary equipment and personnel. Do not operate controls to cause one or more wheels to leave the ground.

### Righting of Tipped Machine

---

A forklift of suitable capacity or equivalent equipment should be placed under the elevated side of the chassis, with a crane or other suitable lifting equipment used to lift the platform while the chassis is lowered by the forklift or other equipment.

### Post-Incident Inspection

---

Following any accident, thoroughly inspect the machine and test all functions first from the ground controls, then from the platform controls. Do not lift above 3 meters until you are certain that all damage has been repaired, if required, and that all controls are operating correctly.

---

## 5.4 EMERGENCY OPERATION

### Use of Ground Controls

---

#### **WARNING**

**KNOW HOW TO USE THE GROUND CONTROLS IN AN EMERGENCY SITUATION.**

Ground personnel must be thoroughly familiar with the machine operating characteristics and the ground control functions. Training should include operation of the machine, review and understanding of this section and hands-on operation of the controls in simulated emergencies.

### Operator Unable to Control Machine

---

#### **WARNING**

**IF THE PLATFORM OPERATOR IS PINNED, TRAPPED OR UNABLE TO OPERATE OR CONTROL THE MACHINE.**

1. Operate the machine from ground controls **ONLY** with the assistance of other personnel and equipment (cranes, overhead hoists, etc.) as may be required to safely remove the danger or emergency condition.
2. Other qualified personnel on the platform may use the platform controls. **DO NOT CONTINUE OPERATION IF CONTROLS DO NOT FUNCTION NORMALLY.**

---

## 5.5 INCIDENT NOTIFICATION

It is imperative that JLG Industries, Inc. be notified immediately of any incident involving a JLG product. Even if no injury or property damage is evident, the Product Safety and Reliability Department at the factory should be contacted by telephone and provided with all necessary details.

It should be noted that failure to notify the Manufacturer of an incident involving a JLG Industries product within 48 hours of such an occurrence may void any warranty consideration on that particular machine.









Corporate Office  
JLG Industries, Inc.  
1 JLG Drive  
McConnellsburg PA. 17233-9533  
USA  
Phone: (717) 485-5161  
Fax: (717) 485-6417

## JLG Worldwide Locations

---

JLG Industries (Australia)  
P.O. Box 5119  
11 Bolwarra Road  
Port Macquarie  
N.S.W. 2444  
Australia  
Phone: (61) 2 65 811111  
Fax: (61) 2 65 810122

JLG Industries (UK)  
Unit 12, Southside  
Bredbury Park Industrial Estate  
Bredbury  
Stockport  
SK6 2sP  
England  
Phone: (44) 870 200 7700  
Fax: (44) 870 200 7711

JLG Deutschland GmbH  
Max Planck Strasse 21  
D-27721 Ritterhude/Idpohl  
Bei Bremen  
Germany  
Phone: (49) 421 693 500  
Fax: (49) 421 693 5035

JLG Industries (Italia)  
Via Po. 22  
20010 Pregnana Milanese - MI  
Italy  
Phone: (39) 02 9359 5210  
Fax: (39) 02 9359 5845

JLG Latino Americana Ltda.  
Rua Eng. Carlos Stevenson,  
80-Suite 71  
13092-310 Campinas-SP  
Brazil  
Phone: (55) 19 3295 0407  
Fax: (55) 19 3295 1025

JLG Europe B.V.  
Jupiterstraat 234  
2132 HJ Foofddorp  
The Netherlands  
Phone: (31) 23 565 5665  
Fax: (31) 23 557 2493

JLG Industries (Norge AS)  
Sofeimyrveien 12  
N-1412 Sofienyr  
Norway  
Phone: (47) 6682 2000  
Fax: (47) 6682 2001

JLG Polska  
Ul. Krolewska  
00-060 Warszawa  
Poland  
Phone: (48) 91 4320 245  
Fax: (48) 91 4358 200

JLG Industries (Europe)  
Kilmartin Place,  
Tannochside Park  
Uddingston G71 5PH  
Scotland  
Phone: (44) 1 698 811005  
Fax: (44) 1 698 811055

JLG Industries (Pty) Ltd.  
Unit 1, 24 Industrial Complex  
Herman Street  
Meadowdale  
Germiston  
South Africa  
Phone: (27) 11 453 1334  
Fax: (27) 11 453 1342

Plataformas Elevadoras  
JLG Iberica, S.L.  
Trapadella, 2  
P.I. Castellbisbal Sur  
08755Castellbisbal  
Spain  
Phone: (34) 93 77 24700  
Fax: (34) 93 77 11762

JLG Industries (Sweden)  
Enkopingsvagen 150  
Box 704  
SE - 175 27 Jarfalla  
Sweden  
Phone: (46) 8 506 59500  
Fax: (46) 8 506 59534