

# **Carryall 500/550/700 Vehicle Owner's Manual**

**Electric and Gasoline**

**[Refer to back cover for applicable build code range]**





## NOTICE

---

This manual is valid for vehicles manufactured in the build code range provided on the back cover of this manual. If the vehicle build code is different from that shown on the back cover of this manual, please contact your nearest dealer or go to [www.clubcar.com](http://www.clubcar.com) to retrieve the proper owner's manual for the vehicle. See also Model Identification in this manual.

Warranty information appears at the end of this manual. No other warranties, express or implied, are contained herein. Your authorized representative checked the vehicle before it was delivered to you and will provide you a copy of the completed vehicle warranty registration form.

Club Car is not liable for errors in this manual or for incidental or consequential damages that result from the use of the material in this manual.

This manual contains proprietary information that is protected by copyright. All rights are reserved. No part of this manual may be photocopied, reproduced, or translated to another language without the written consent of Club Car, LLC.

The information contained in this document is subject to change without notice. Club Car reserves the right to make design changes to vehicles without obligation to make these changes on units previously sold.

These utility vehicles are four-wheel, general-purpose vehicles intended to transport people and cargo on improved or groomed surfaces.

These vehicles do not conform to U.S. Federal Motor Vehicle Safety Standards (FMVSS) for automobiles or to FMVSS 500 for low-speed vehicles, and are not equipped for operation on public streets, roads, or highways.

If in English, this manual is the Original Instructions provided by the manufacturer. If in any language other than English, this manual is a translation of the Original Instructions.



**P.O. Box 204658  
Augusta, Georgia 30917-4658 USA  
Telephone 706-863-3000  
Service Parts Fax 706-855-7413  
[www.clubcar.com](http://www.clubcar.com)**

Copyright © 2013, 2014, 2015 Club Car, LLC  
*Club Car, Tranquility, and ArmorFlex*  
are registered trademarks of Club Car, LLC  
This manual effective June 2015

## FOREWORD

---

Thank you for choosing Club Car, the name most widely recognized as the industry leader in vehicle efficiency and long-lasting value. You have chosen the finest utility vehicle on the market. Please protect your investment and ensure that your Club Car vehicle(s) provides years of reliable, superior performance by reading and following the maintenance instructions in this manual.

Your comfort and safety are important to us, so we urge you to read and follow the step-by-step operating instructions and safety procedures in this manual. These instructions must be followed in order to avoid the risk of severe personal injury. If you rent or loan your vehicle to others, we recommend that you ask them to read this manual before they operate the vehicle.

Club Car products are backed by a customer support system designed to offer you fast, courteous service. In the event your Club Car vehicle needs repairs or service, please contact your local authorized Club Car dealer or distributor, who will be able to provide technical advice, perform warranty work, and sell parts and service manuals.

To find your local authorized Club Car dealer, visit [www.clubcardealer.com](http://www.clubcardealer.com), call 1-800-ClubCar (258-2227), or scan this Quick Response (QR) code to be taken to the Club Car dealer locator. Refer to Figure 1. Download a QR code reader such as RedLaser or Barcode Scanner to your cell phone or tablet.

If you would prefer to write to us, direct your letter to: Club Car LLC, Attention: Marketing Services, P.O. Box 204658, Augusta, Georgia 30917-4658 USA.

We hope you will consider this owner's manual a permanent part of your Club Car vehicle. If you sell the vehicle, please include the manual so that the next owner will have the important operating, safety, and maintenance information it contains.

Dealer Locator QR Code



3118

Figure 1 Dealer Locator QR Code

| MAINTENANCE ITEMS   |  |
|---|--|
| <b>Battery Terminal Protector Spray</b><br>CC PN 1014305                  | <b>Dry Moly Lube</b><br>CC PN 1012151                |
| <b>Chassis Lube</b><br>EP NLGI Grade 2 (commercially available)           | <b>Engine Air Filter (404 cc)</b><br>CC PN 102558201 |
| <b>Deionizer Filter Replacement Cartridge (SPWS)</b><br>CC PN 104005901   | <b>Spark Plug O.H.C. (404 cc)</b><br>CC PN 105017801 |
| <b>Deionizer Filter Replacement Cartridge (non-SPWS)</b><br>CC PN AM10975 |  |

# TABLE OF CONTENTS

---

|   |    |
|---|----|
| Technical Publication Customer Satisfaction Survey..... | 4  |
| Safety Decal Identification.....                        | 5  |
| Practice Safety.....                                    | 15 |
| Proposition 65 – State of California.....               | 15 |
| Safety Details.....                                     | 16 |
| General Warnings.....                                   | 16 |
| General Information.....                                | 21 |
| Model Identification.....                               | 22 |
| Controls and Indicators.....                            | 22 |
| Pre-Operation and Daily Safety Checklist.....           | 31 |
| Driving Instructions.....                               | 33 |
| Loading and Unloading.....                              | 36 |
| Vehicle Load Capacities.....                            | 36 |
| Towing with the Vehicle.....                            | 38 |
| Transporting on a Trailer.....                          | 39 |
| Storage – Electric Vehicles.....                        | 39 |
| Storage – Gasoline Vehicles.....                        | 41 |
| Maintenance.....  | 43 |
| Periodic Service Schedules.....                         | 44 |
| Periodic Lubrication Schedules.....                     | 47 |
| Batteries – Electric Vehicles.....                      | 49 |
| Battery Charger, QuiQ™ – Electric Vehicle.....          | 53 |
| Single Point Watering System (SPWS).....                | 59 |
| Battery – Gasoline Vehicle.....                         | 61 |
| Engine Oil – Gasoline Vehicle.....                      | 63 |
| Fueling Instructions – Gasoline Vehicle.....            | 66 |
| Cleaning the Vehicle.....                               | 67 |
| Accessories.....  | 68 |
| Subsequent Owner Registration.....                      | 68 |
| Vehicle Specifications.....                             | 69 |
| Warranties.....   | 74 |
| EC Declaration of Conformity.....                       | 82 |

## TECHNICAL PUBLICATION CUSTOMER SATISFACTION SURVEY

---

Let your voice be heard!

Please participate in the Technical Publication customer satisfaction online survey. This survey takes less than five minutes to complete and your responses will help examine current performance and identify areas for future improvement.

Our top priority is to provide timely, accurate, and user friendly manuals.

The online survey can be found at <http://bit.ly/1w9uFMh> or using the QR Code below.



Figure 2 Technical Publication Customer Satisfaction Online Survey

# SAFETY DECAL IDENTIFICATION

The following pages contain safety decal information. For detailed information on specific features, read the appropriate section in this manual.

## ELECTRIC CARRYALL 500

**WARNING**

Unintended vehicle movement may cause severe injury or death. Before using vehicle, read owner's manual and vehicle safety warnings.

Before leaving vehicle:

- Engage park brake to lock wheels.
- Place vehicle in NEUTRAL.
- Turn key to OFF and remove key.

105046101

**WARNING**

UNINTENDED MOVEMENT, ROLLOVER, OR FALLING OUT CAN CAUSE SERIOUS INJURY OR DEATH.

- Vehicle to be operated by licensed and authorized persons only.
- Use in authorized areas only. Do not operate on public roads.
- One (1) person per bucket seat maximum.
- Two (2) persons per bench seat maximum.
- Operate from driver's seat only.
- Do not start vehicle until all occupants are fully seated.
- Drive slowly in turns and straight up and down slopes.
- Remain fully seated while moving.
- Hold on and keep entire body inside vehicle while moving.
- Never attempt jumps and avoid extreme braking in reverse.
- Do not leave children unattended in vehicle at any time.
- Children requiring a child safety seat must not ride in vehicle.
- Never operate under the influence of alcohol or drugs.

104026801

**12V (+)** 105163601

**(+) 12V ACC. FUSE BLOCK** 105130101

**GND (-)** 105163701

**WARNING**

Riding in cargo bed can cause severe injury or death. Do not ride in cargo bed.

101609401

**WARNING**

CRUSH AREA

STAY CLEAR

101609401

**VEHICLE LOADING**

Read owner's manual and warnings on dash.

- Vehicle rated capacity: 1200 lb (544 kg) on level surface only. Includes occupants and cargo load.
- Maximum cargo load: 800 lb (363 kg) Includes cargo, bed load, and optional equipment.
- Vehicle combination rated capacity: 1500 lb (680 kg) Includes vehicle rated capacity and gross trailer weight.

**WARNING**

ROLLOVER CAN CAUSE SERIOUS INJURY OR DEATH.

- Place cargo forward in the cargo bed and distribute evenly side to side. Secure load.
- On uneven or steep terrain, reduce speed and load.
- Avoid stopping on or backing down steep hills.
- Avoid top-heavy loads.

105137106

2852

|   |           |   |   |           |  |
|---|-----------|---|---|-----------|--|
| 1 | 101553901 | Decal, Bed Loading Warning (on cargo bed or seat back)  | 6 | 105130101 | Decal, 12V Accessory Fuse Block (under front body) |
| 2 | 101609401 | Decal, Crush Area Warning (behind seat, near cargo bed) | 7 | 105137106 | Decal, Vehicle Load                                |
| 3 | 101825101 | Decal, On/Off Key Switch (above key switch)             | 8 | 105163601 | Decal, 12V (+) (under front body)                  |
| 4 | 104026801 | Decal, Occupant Warning                                 | 9 | 105163701 | Decal, Ground (under front body)                   |
| 5 | 105046101 | Decal, Operating Instructions                           |   |           |  |

# ELECTRIC CARRYALL 550

**⚠ WARNING**

Unintended vehicle movement may cause severe injury or death. Before using vehicle, read owner's manual and vehicle safety warnings.

Before leaving vehicle:

- Engage park brake to lock wheels.
- Place vehicle in NEUTRAL.
- Turn key to OFF and remove key.

105046101

**⚠ WARNING**

**UNINTENDED MOVEMENT, ROLLOVER, OR FALLING OUT CAN CAUSE SERIOUS INJURY OR DEATH.**

- Vehicle to be operated by licensed and authorized persons only.
- Use in authorized areas only. Do not operate on public roads.
- One (1) person per bucket seat maximum.
- Two (2) persons per bench seat maximum.
- Operate from driver's seat only.
- Do not start vehicle until all occupants are fully seated.
- Drive slowly in turns and straight up and down slopes.
- Remain fully seated while moving.
- Hold on and keep entire body inside vehicle while moving.
- Never attempt jumps and avoid extreme braking in reverse.
- Do not leave children unattended in vehicle at any time.
- Children requiring a child safety seat must not ride in vehicle.
- Never operate under the influence of alcohol or drugs.

104026801

**12V (+)** 105163601

**(+) 12V ACC. FUSE BLOCK** 105130101

**GND (-)** 105163701

**⚠ WARNING**

**Riding in cargo bed can cause severe injury or death. Do not ride in cargo bed.** 101553901

**⚠ WARNING CRUSH AREA** 101609401

**STAY CLEAR**

**UNDER 16**

**⚠ WARNING**

**YOUNG DRIVERS OR PASSENGERS INCREASE CHANCE OF SERIOUS INJURY OR DEATH**

- All occupants must be able to hold on and place both feet flat on the floorboard with their backs against the seat backs. Children requiring a child safety seat must not ride in vehicle.
- A valid driver's license is required to operate this vehicle.

102075801

**VEHICLE LOADING**

Read owner's manual and warnings on dash.

- Vehicle rated capacity: 900 lb (408 kg) on level surface only.
- Includes occupants and cargo load.
- Maximum cargo load: 500 lb (227 kg)
- Includes cargo, bed load, and optional equipment.
- Vehicle combination rated capacity: 900 lb (408 kg)
- Includes vehicle rated capacity and gross trailer weight.

**⚠ WARNING**

**ROLLOVER CAN CAUSE SERIOUS INJURY OR DEATH.**

- Place cargo forward in the cargo bed and distribute evenly side to side. Secure load.
- On uneven or steep terrain, reduce speed and load.
- Avoid stopping on or backing down steep hills.
- Avoid top-heavy loads.

105137103

2873

|   |           |  |    |           |  |
|---|-----------|--|----|-----------|--|
| 1 | 101553901 | Decal, Bed Loading Warning (on cargo bed or seat back) | 6  | 105046101 | Decal, Operating Instructions                      |
| 2 | 101609401 | Decal, Crush Area Warning                              | 7  | 105130101 | Decal, 12V Accessory Fuse Block (under front body) |
| 3 | 101825101 | Decal, On/Off Key Switch (above key switch)            | 8  | 105137103 | Decal, Vehicle Load                                |
| 4 | 102075801 | Decal, Young Driver Warning                            | 9  | 105163601 | Decal, 12V (+) (under front body)                  |
| 5 | 104026801 | Decal, Occupant Warning                                | 10 | 105163701 | Decal, Ground (under front body)                   |

## ELECTRIC CARRYALL 500 AND 550, CONTINUED

**WARNING**

**AVOID FIRE HAZARD**

- Replacement battery wires must be 4-gauge (AWG) with low-resistance terminals equivalent to factory-installed wires.
- Ensure that battery connections are clean and properly tightened. See owner's manual.

CCI 102967601

**CAUTION**

**EXPOSURE TO WATER MAY DAMAGE ELECTRONIC COMPONENTS**

- Do not operate vehicle without this cover properly installed.
- Do not direct water stream in the area of the cover without cover securely in place.
- See vehicle maintenance and service manual before servicing.

CCI 102518301

**CAUTION**

Frame is isolated from power system. Do not use as ground.

105124701

(+ 48V ACC. FUSE BLOCK 105130001

GND (-) 105163701

**NOTICE**

MAXIMUM TONGUE WEIGHT-150 lb. (667 N)

1011553

**WARNING**

BATTERY EXPLOSION COULD RESULT IN SEVERE PERSONAL INJURY.

- Do not store items in battery compartment.
- Place Run/Tow switch in TOW position before:
  - Disconnecting or connecting battery cables
  - Towing this vehicle
  - Extended storage
  - Servicing the vehicle

NORMAL

TRIPPED

TOW

RUN

CCI 102845101

LATCH

OPEN

**WARNING**

Crush area. Can cause severe injury. Stay clear when closing bed.

CCI 102459301

2853

# ELECTRIC CARRYALL 700

**⚠ WARNING**

Unintended vehicle movement may cause severe injury or death. Before using vehicle, read owner's manual and vehicle safety warnings.

Before leaving vehicle:

- Engage park brake to lock wheels.
- Place vehicle in NEUTRAL.
- Turn key to OFF and remove key.

105046101

**⚠ WARNING**

UNINTENDED MOVEMENT, ROLLOVER, OR FALLING OUT CAN CAUSE SERIOUS INJURY OR DEATH.

- Vehicle to be operated by licensed and authorized persons only.
- Use in authorized areas only. Do not operate on public roads.
- One (1) person per bucket seat maximum.
- Two (2) persons per bench seat maximum.
- Operate from driver's seat only.
- Do not start vehicle until all occupants are fully seated.
- Drive slowly in turns and straight up and down slopes.
- Remain fully seated while moving.
- Hold on and keep entire body inside vehicle while moving.
- Never attempt jumps and avoid extreme braking in reverse.
- Do not leave children unattended in vehicle at any time.
- Children requiring a child safety seat must not ride in vehicle.
- Never operate under the influence of alcohol or drugs.

104026801

**12V (+)** 105163601

**(+) 12V ACC. FUSE BLOCK** 105130101

**GND (-)** 105163701

**⚠ WARNING**

Riding in cargo bed can cause severe injury or death. Do not ride in cargo bed. CCI 101553901

**VEHICLE LOADING**

Read owner's manual and warnings on dash.

- Vehicle rated capacity: 1500 lb (680 kg) on level surface only. Includes occupants and cargo load.
- Maximum cargo load: 1000 lb (454 kg) Includes cargo, bed load, and optional equipment.
- Vehicle combination rated capacity: 1500 lb (680 kg) Includes vehicle rated capacity and gross trailer weight.

**⚠ WARNING**

ROLLOVER CAN CAUSE SERIOUS INJURY OR DEATH.

- Place cargo forward in the cargo bed and distribute evenly side to side. Secure load.
- On uneven or steep terrain, reduce speed and load.
- Avoid stopping on or backing down steep hills.
- Avoid top-heavy loads.

105151501

**⚠ WARNING**

**CRUSH AREA**

**STAY CLEAR**

CCI 101609401

2854

## ELECTRIC CARRYALL 700, CONTINUED

**WARNING**

**AVOID FIRE HAZARD**

- Replacement battery wires must be 4-gauge (AWG) with low-resistance terminals equivalent to factory-installed wires.
- Ensure that battery connections are clean and properly tightened. See owner's manual.

CCI 102967601

**CAUTION**

**EXPOSURE TO WATER MAY DAMAGE ELECTRONIC COMPONENTS**

- Do not operate vehicle without this cover properly installed.
- Do not direct water stream in the area of the cover without cover securely in place.
- See vehicle maintenance and service manual before servicing.

CCI 102518301

**CAUTION**

Frame is isolated from power system. Do not use as ground.

105124701

**(+) 48V ACC. FUSE BLOCK**

105130001

**GND (-)**

105163701

**NOTICE**

**MAXIMUM TONGUE WEIGHT—150 lb. (667 N)**

1011553

**WARNING**

**BATTERY EXPLOSION COULD RESULT IN SEVERE PERSONAL INJURY.**

- Do not store items in battery compartment.
- Place Run/Tow switch in TOW position before:
  - Disconnecting or connecting battery cables
  - Towing this vehicle
  - Extended storage
  - Servicing the vehicle

NORMAL

TRIPPED

TOW

RUN

CCI 102845101

2855

|   |           |  |   |           |  |
|---|-----------|--|---|-----------|--|
| 1 | 1011553   | Decal, Trailer Hitch Tongue Weight Notice (on trailer/receiver hitch)            | 5 | 105124701 | Decal, Do Not Use as Ground (on frame above electrical component mounting plate) |
| 2 | 102518301 | Decal, Component Cover Notice (on electrical component cover)                    | 6 | 105130001 | Decal, 48V Accessory Fuse Block (on electrical component mounting plate)         |
| 3 | 102845101 | Decal, Tow Switch Warning (on Tow/Run switch plate, under seat)                  | 7 | 105163701 | Decal, Ground (on electrical component mounting plate)                           |
| 4 | 102967601 | Decal, 4 Gauge Wire Warning (on frame above electrical component mounting plate) |   |           |  |

# GASOLINE CARRYALL 500

**⚠ WARNING**

Unintended vehicle movement may cause severe injury or death. Before using vehicle, read owner's manual and vehicle safety warnings.

Before leaving vehicle:

- Engage park brake to lock wheels.
- Place vehicle in NEUTRAL.
- Turn key to OFF and remove key.

105046101

**⚠ WARNING**

UNINTENDED MOVEMENT, ROLLOVER, OR FALLING OUT CAN CAUSE SERIOUS INJURY OR DEATH.

- Vehicle to be operated by licensed and authorized persons only.
- Use in authorized areas only. Do not operate on public roads.
- One (1) person per bucket seat maximum.
- Two (2) persons per bench seat maximum.
- Operate from driver's seat only.
- Do not start vehicle until all occupants are fully seated.
- Drive slowly in turns and straight up and down slopes.
- Remain fully seated while moving.
- Hold on and keep entire body inside vehicle while moving.
- Never attempt jumps and avoid extreme braking in reverse.
- Do not leave children unattended in vehicle at any time.
- Children requiring a child safety seat must not ride in vehicle.
- Never operate under the influence of alcohol or drugs.

104026801

**⚠ WARNING**

Riding in cargo bed can cause severe injury or death. Do not ride in cargo bed.

CA 101553901

**⚠ WARNING**

CRUSH AREA

STAY CLEAR

101609401

**VEHICLE LOADING**

Read owner's manual and warnings on dash.

- Vehicle rated capacity: 1200 lb (544 kg) on level surface only.
- Includes occupants and cargo load.
- Maximum cargo load: 800 lb (363 kg)
- Includes cargo, bed load, and optional equipment.
- Vehicle combination rated capacity: 1200 lb (544 kg)
- Includes vehicle rated capacity and gross trailer weight.

105137102

**⚠ WARNING**

ROLLOVER CAN CAUSE SERIOUS INJURY OR DEATH.

- Place cargo forward in the cargo bed and distribute evenly side to side. Secure load.
- On uneven or steep terrain, reduce speed and load.
- Avoid stopping on or backing down steep hills.
- Avoid top-heavy loads.

105137106

**VEHICLE LOADING**

Read owner's manual and warnings on dash.

- Vehicle rated capacity: 1200 lb (544 kg) on level surface only.
- Includes occupants and cargo load.
- Maximum cargo load: 800 lb (363 kg)
- Includes cargo, bed load, and optional equipment.
- Vehicle combination rated capacity: 1500 lb (680 kg)
- Includes vehicle rated capacity and gross trailer weight.

105137106

**⚠ WARNING**

ROLLOVER CAN CAUSE SERIOUS INJURY OR DEATH.

- Place cargo forward in the cargo bed and distribute evenly side to side. Secure load.
- On uneven or steep terrain, reduce speed and load.
- Avoid stopping on or backing down steep hills.
- Avoid top-heavy loads.

105137106

2856

|   |           |  |   |           |   |
|---|-----------|--|---|-----------|---|
| 1 | 101553901 | Decal, Bed Loading Warning (on cargo bed or seat back)                 | 5 | 104026801 | Decal, Occupant Warning                         |
| 2 | 101609401 | Decal, Crush Area Warning (behind seat, near cargo bed)                | 6 | 105046101 | Decal, Operating Instructions                   |
| 3 | 101825101 | Decal, On/Off Key Switch (above key switch) (pedal-start vehicles)     | 7 | 105137102 | Decal, Vehicle Load (two-wheel brake vehicles)  |
| 4 | 101825102 | Decal, On/Off/Start Key Switch (above key switch) (key-start vehicles) | 8 | 105137106 | Decal, Vehicle Load (four-wheel brake vehicles) |

# GASOLINE CARRYALL 550

**⚠ WARNING**

Unintended vehicle movement may cause severe injury or death. Before using vehicle, read owner's manual and vehicle safety warnings.

**Before leaving vehicle:**

- Engage park brake to lock wheels.
- Place vehicle in NEUTRAL.
- Turn key to OFF and remove key.

105046101

**⚠ WARNING**

**UNINTENDED MOVEMENT, ROLLOVER, OR FALLING OUT CAN CAUSE SERIOUS INJURY OR DEATH.**

- Vehicle to be operated by licensed and authorized persons only.
- Use in authorized areas only. Do not operate on public roads.
- One (1) person per bucket seat maximum.
- Two (2) persons per bench seat maximum.
- Operate from driver's seat only.
- Do not start vehicle until all occupants are fully seated.
- Drive slowly in turns and straight up and down slopes.
- Remain fully seated while moving.
- Hold on and keep entire body inside vehicle while moving.
- Never attempt jumps and avoid extreme braking in reverse.
- Do not leave children unattended in vehicle at any time.
- Children requiring a child safety seat must not ride in vehicle.
- Never operate under the influence of alcohol or drugs.

104026801

**⚠ WARNING**

**Riding in cargo bed can cause severe injury or death. Do not ride in cargo bed.**

101609401

**⚠ WARNING**

**CRUSH AREA**

**STAY CLEAR**

101609401

**⚠ WARNING**

**YOUNG DRIVERS OR PASSENGERS INCREASE CHANCE OF SERIOUS INJURY OR DEATH**

- All occupants must be able to hold on and place both feet flat on the floorboard with their backs against the seat backs. Children requiring a child safety seat must not ride in vehicle.
- A valid driver's license is required to operate this vehicle.

102075801

**⚠ WARNING**

**ROLLOVER CAN CAUSE SERIOUS INJURY OR DEATH.**

- Place cargo forward in the cargo bed and distribute evenly side to side. Secure load.
- On uneven or steep terrain, reduce speed and load.
- Avoid stopping on or backing down steep hills.
- Avoid top-heavy loads.

105137103

**VEHICLE LOADING**

Read owner's manual and warnings on dash.

- Vehicle rated capacity: 900 lb (408 kg) on level surface only.
  - Includes occupants and cargo load.
- Maximum cargo load: 500 lb (227 kg)
  - Includes cargo, bed load, and optional equipment.
- Vehicle combination rated capacity: 900 lb (408 kg)
  - Includes vehicle rated capacity and gross trailer weight.

2874

|   |           |  |   |           |                               |
|---|-----------|--|---|-----------|-------------------------------|
| 1 | 101553901 | Decal, Bed Loading Warning (on cargo bed or seat back)                 | 5 | 102075801 | Decal, Young Driver Warning   |
| 2 | 101609401 | Decal, Crush Area Warning (behind seat, near cargo bed)                | 6 | 104026801 | Decal, Occupant Warning       |
| 3 | 101825101 | Decal, On/Off Key Switch (above key switch) (pedal-start vehicles)     | 7 | 105046101 | Decal, Operating Instructions |
| 4 | 101825102 | Decal, On/Off/Start Key Switch (above key switch) (key-start vehicles) | 8 | 105137103 | Decal, Vehicle Load           |

## GASOLINE CARRYALL 500 AND 550, CONTINUED

**WARNING**  
**GASOLINE EXPLOSION / FIRE CAN CAUSE SERIOUS INJURY OR DEATH.**  
 • No sparks or open flame near fuel or fuel tank.  
 • No smoking near fuel or fuel tank.  
 • Stop engine and allow to cool before refueling.  
 • Do not disconnect pressurized fuel lines.  
105082301

**WARNING**  
**GASOLINE EXPLOSION / FIRE CAN CAUSE SERIOUS INJURY OR DEATH.**  
 • No sparks or open flame near fuel or fuel tank.  
 • No smoking near fuel or fuel tank.  
 • Stop engine and allow to cool before refueling.  
105084701

**WARNING**  
**CAN CAUSE SEVERE INJURY**  
  
**Rotating parts**  
  
**HOT manifold & muffler**  
**KEEP CLEAR** CCJ 101960501

**NOTICE**  
**MAXIMUM TONGUE WEIGHT-150 lb. (667 N)**  
1011553

**WARNING**  
**VEHICLE MOVEMENT MAY CAUSE SERIOUS INJURY**  
 When switch is in Maintenance position, chock wheels and firmly set park brake.  
CCJ 103205501

**WARNING**  
**INCORRECT WIRING COULD RESULT IN SEVERE INJURY OR DEATH.**  
 • Diode and solenoid connections must have correct polarity.  
 • Keep all persons clear of engine body when making final connections.  
CCJ 102345901

**WARNING**  
**Crush area. Can cause severe injury. Stay clear when closing bed.**  
CCJ 102459301

**WARNING**  
**Negative frame ground. Can cause severe injury. Do not contact positive (+) battery post or cable to frame. Disconnect negative battery lead first.**

**WARNING**  
**Excessive speed. Can cause severe injury or death. Do not tamper with engine governor adjustment.**  
CCJ 101915201

2857

# GASOLINE CARRYALL 700

**⚠ WARNING**

Unintended vehicle movement may cause severe injury or death. Before using vehicle, read owner's manual and vehicle safety warnings.

**Before leaving vehicle:**

- Engage park brake to lock wheels.
- Place vehicle in NEUTRAL.
- Turn key to OFF and remove key.

105046101

**⚠ WARNING**

**UNINTENDED MOVEMENT, ROLLOVER, OR FALLING OUT CAN CAUSE SERIOUS INJURY OR DEATH.**

- Vehicle to be operated by licensed and authorized persons only.
- Use in authorized areas only. Do not operate on public roads.
- One (1) person per bucket seat maximum.
- Two (2) persons per bench seat maximum.
- Operate from driver's seat only.
- Do not start vehicle until all occupants are fully seated.
- Drive slowly in turns and straight up and down slopes.
- Remain fully seated while moving.
- Hold on and keep entire body inside vehicle while moving.
- Never attempt jumps and avoid extreme braking in reverse.
- Do not leave children unattended in vehicle at any time.
- Children requiring a child safety seat must not ride in vehicle.
- Never operate under the influence of alcohol or drugs.

104026801

OFF | ON (3)

OFF ON|START (4)

**⚠ WARNING**

Riding in cargo bed can cause severe injury or death. Do not ride in cargo bed.

101638401

**VEHICLE LOADING**

Read owner's manual and warnings on dash.

- Vehicle rated capacity: 1500 lb (680 kg) on level surface only.
- Includes occupants and cargo load.
- Maximum cargo load: 1000 lb (454 kg)
- Includes cargo, bed load, and optional equipment.
- Vehicle combination rated capacity: 1500 lb (680 kg)
- Includes vehicle rated capacity and gross trailer weight.

**⚠ WARNING**

**ROLLOVER CAN CAUSE SERIOUS INJURY OR DEATH.**

- Place cargo forward in the cargo bed and distribute evenly side to side. Secure load.
- On uneven or steep terrain, reduce speed and load.
- Avoid stopping on or backing down steep hills.
- Avoid top-heavy loads.

105151501

**⚠ WARNING**

**CRUSH AREA**

STAY CLEAR

101638401

2858

## GASOLINE CARRYALL 700, CONTINUED

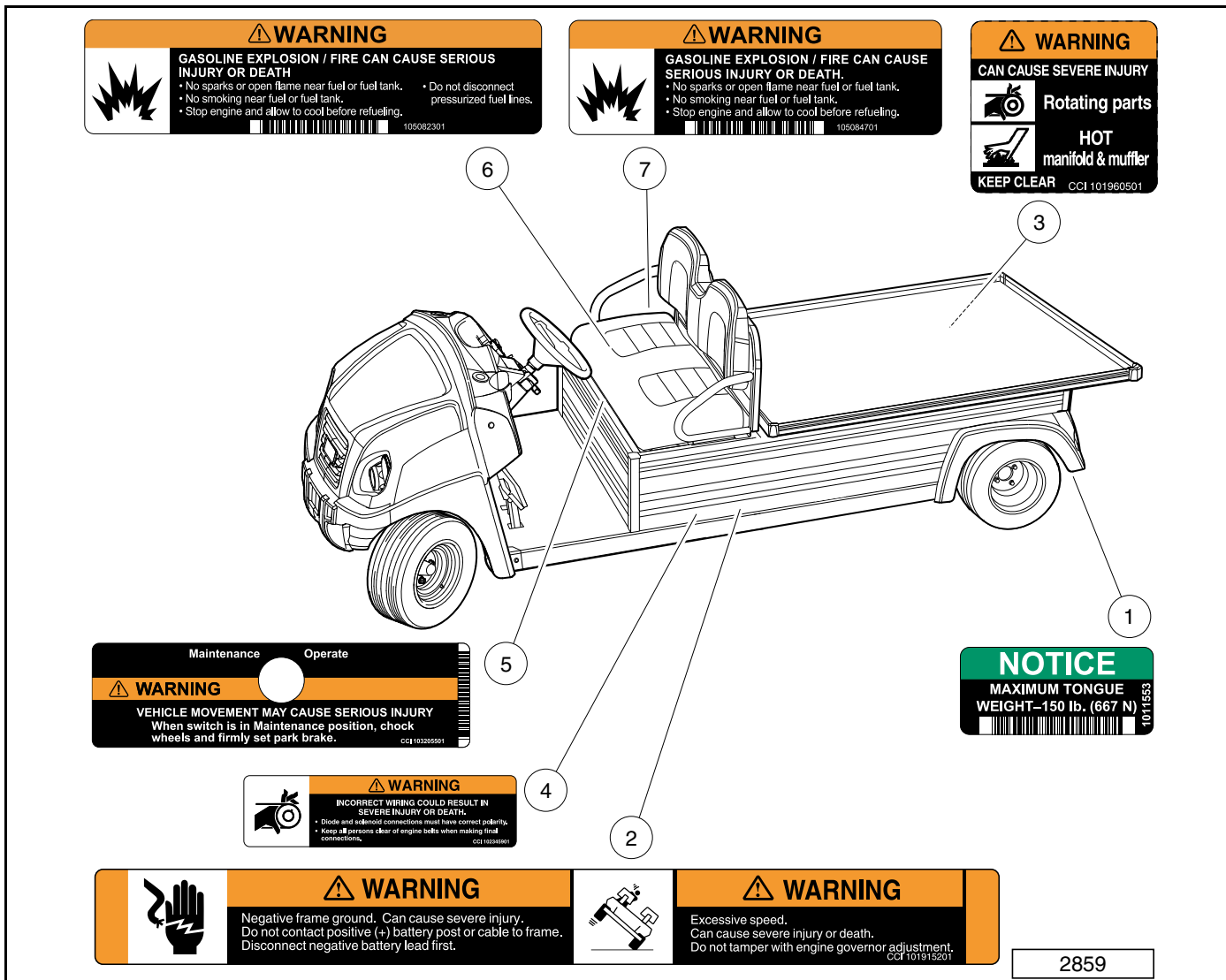

|   |           |   |   |           |  |
|---|-----------|---|---|-----------|--|
| 1 | 1011553   | Decal, Trailer Hitch Tongue Weight Notice (on trailer/receiver hitch) | 5 | 103205501 | Decal, Maintenance/Operate Warning (on Maintenance/Operate switch plate, under seat) |
| 2 | 101915201 | Decal, Frame Ground/Governor Warning (on vehicle frame near battery)  | 6 | 105082301 | Decal, Gasoline Fuel Warning (on fuel tank)  |
| 3 | 101960501 | Decal, Rotating Parts/Hot Manifold Warning (on starter/generator)     | 7 | 105084701 | Decal, Gasoline Fuel Warning (at fuel fill)  |
| 4 | 102345901 | Decal, Diode Warning (near battery)                                   |   |           |  |

---

**PRACTICE SAFETY**

---



399  
Figure 3 Practice Safety

Safety signs like you see above may at first seem shocking, but their impact is mild compared with the reality of severe personal injury.

Your safety and satisfaction are of the utmost importance to us. That is why before operating the vehicle, we urge you to review the information in this manual. Understand and become familiar with the DANGER, WARNING, and CAUTION statements and procedures it contains, along with the safety decals that are affixed to your vehicle.

Take time to understand the language of safety. It is a language that can save your life.

---

**PROPOSITION 65 – STATE OF CALIFORNIA**

---

**⚠ WARNING**

- This product contains or emits chemicals or substances that have been determined by the state of California to cause cancer and birth defects or other reproductive harm.

## SAFETY DETAILS

---

### **WARNING**

---

- This owner's manual should be read completely before attempting to drive or service the vehicle. Failure to follow the instructions in this manual can result in property damage, severe personal injury, or death.

It is important to note that some vital statements throughout this manual and on the decals affixed to the vehicle are preceded by the words DANGER, WARNING, or CAUTION. For your protection, we recommend that you take special notice of these safety precautions. Safety precautions are essential and must be followed.

If any of the operation or safety decals on the vehicle become damaged, have been removed, or cannot be easily read, they should be replaced immediately to avoid possible property damage, personal injury, or death. Contact your distributor/dealer.

### **DANGER**

---

- A DANGER indicates an immediate hazard that will result in severe personal injury or death.

### **WARNING**

---

- A WARNING indicates an immediate hazard that can result in severe personal injury or death.

### **CAUTION**

---

- A CAUTION with the safety alert symbol indicates a hazard or unsafe practice that can result in minor personal injury.

### **CAUTION**

---

- A CAUTION without the safety alert symbol indicates a potentially hazardous situation that can result in property damage.

## GENERAL WARNINGS

---

The following safety statements must be heeded whenever the vehicle is being operated, repaired, or serviced. **See Safety Decal Identification on page 5.** Other specific safety statements appear throughout this manual and on the vehicle.

## **⚠ DANGER**

- **Battery – Explosive gases! Do not smoke. Keep sparks and flames away from the vehicle and service area. Ventilate when charging or operating vehicle in an enclosed area. Wear a full face shield and rubber gloves when working on or near batteries.**
- **Gasoline – Flammable! Explosive! Do not smoke. Keep sparks and flames away from the vehicle and service area. Service only in a well-ventilated area.**
- **Do not operate engine in an enclosed area without proper ventilation. The engine produces carbon monoxide, which is an odorless, deadly poison.**
- **The vehicle will not provide protection from lightning, flying objects, or other storm-related hazards. If caught in a storm while driving a Club Car vehicle, exit the vehicle and seek shelter in accordance with applicable safety guidelines for your location.**

## **⚠ WARNING**

- **Follow the procedures exactly as stated in this manual, and heed all DANGER, WARNING, and CAUTION statements in this manual as well as those on the vehicle and battery charger.**
- **Do not leave children unattended in vehicle at any time.**
- **Prior to leaving the vehicle unattended or servicing the vehicle, set the park brake, place the Forward/Reverse handle or switch in the NEUTRAL position, turn the key switch to the OFF position, and remove the key. Chock the wheels when servicing the vehicle.**
- **Improper use of the vehicle or failure to properly maintain it can result in decreased vehicle performance, severe personal injury, or death.**
- **Any modification or change to the vehicle that affects the electrical system, stability or handling of the vehicle, or increases maximum vehicle speed beyond factory specifications, can result in severe personal injury or death.**
- **Check the vehicle for proper location of all vehicle safety and operation decals and make sure they are in place and are easy to read.**
- **For vehicles with cargo beds, remove all cargo (including accessories) before raising the bed or servicing the vehicle. If the vehicle is equipped with a prop rod, ensure that it is securely engaged while bed is raised. Do not close bed until all persons are clear of cargo bed area. Keep hands clear of all crush areas. Do not drop cargo bed; lower gently and keep entire body clear. Failure to heed this warning can result in severe personal injury or death.**
- **Only trained technicians should service or repair the vehicle or battery charger. Anyone doing even simple repairs or service should have knowledge and experience in electrical and mechanical repair. The appropriate instructions must be used when performing maintenance, service, or accessory installation.**

### **Electric vehicles only:**

- **Ensure battery connections are clean and properly tightened. See Battery Care – Vehicles Equipped with the Single-Point Watering System (SPWS) on page 51 or Battery Care – Vehicles Without the Single-Point Watering System (SPWS) on page 52.**
- **Place Tow/Run switch in the TOW position before disconnecting or connecting the batteries. Failure to heed this warning can result in a battery explosion or severe personal injury.**
- **To avoid unintentionally starting an electric vehicle, disconnect the batteries and discharge the controller. See Disconnecting the Batteries – Electric Vehicles on page 19.**

**WARNING CONTINUED ON NEXT PAGE**

## **WARNING**

### **Gasoline vehicles only:**

- To avoid unintentionally starting a gasoline vehicle, disconnect the battery and spark plug wire. See **Side-Post Battery: Disconnecting the Battery-Gasoline Vehicles** on page 19. See **Top-Post Battery: Disconnecting the Battery-Gasoline Vehicles** on page 20.
- **Frame ground** – Do not allow tools or other metal objects to contact frame when disconnecting battery cables or other electrical wiring. Do not allow a positive wire to touch the vehicle frame, engine, or any other metal component.

### **All vehicles:**

- **Wear safety glasses or approved eye protection when servicing the vehicle or battery charger. Wear a full face shield and rubber gloves when working on or near batteries.**
- **Do not wear loose clothing or jewelry such as rings, watches, chains, etc., when servicing the vehicle or battery charger.**
- **Use insulated tools when working near batteries or electrical connections. Use extreme caution to avoid shorting of components or wiring.**

## DISABLING THE VEHICLE

1. Engage park brake to lock wheels.
2. Turn the key switch OFF and remove the key.
3. Place the Forward/Reverse control in the NEUTRAL position.
4. In addition, chock the wheels if servicing or repairing the vehicle.

## DISCONNECTING THE BATTERIES – ELECTRIC VEHICLES

1. Disable the vehicle. **See Disabling the Vehicle on page 19.**
2. Place Tow/Run switch in the TOW position before disconnecting or connecting the batteries. Failure to heed this warning can result in a battery explosion or severe personal injury.
3. Disconnect the batteries, negative (–) cable first, as shown (**Figure 4**).
4. After disconnecting the batteries, wait 90 seconds for the controller capacitors to discharge.

## CONNECTING THE BATTERIES – ELECTRIC VEHICLES

1. Ensure the Tow/Run switch is in the TOW position.
2. Connect the battery cables, positive (+) cable first.
3. Tighten battery terminals to 110 in·lb (12.4 N·m).
4. Coat terminals with Battery Terminal Protector Spray to minimize corrosion.

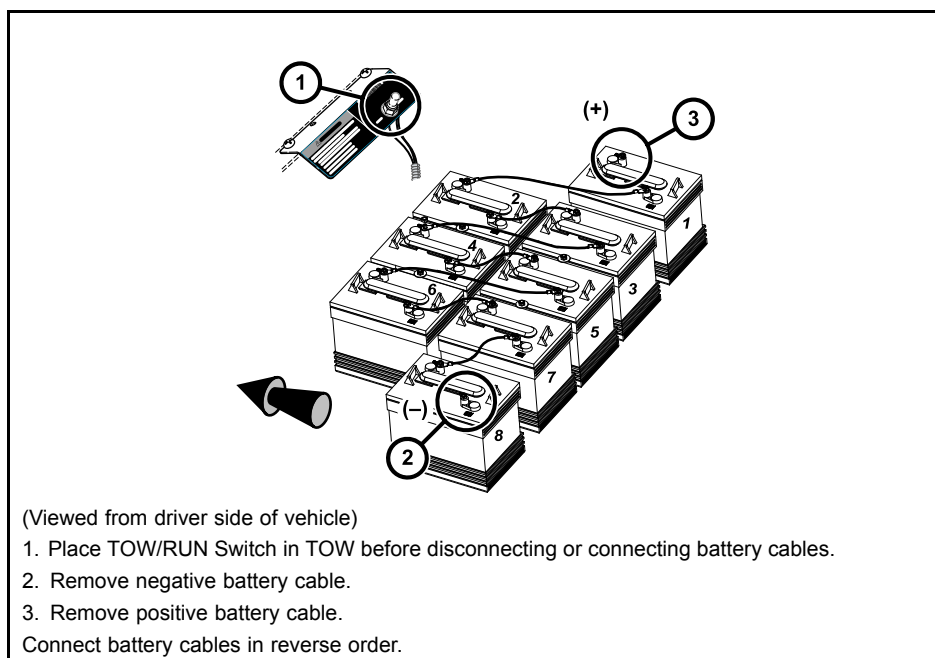

2780

Figure 4 Battery Cable Removal – Electric Vehicle

## SIDE-POST BATTERY: DISCONNECTING THE BATTERY-GASOLINE VEHICLES

1. Disable the vehicle. **See Disabling the Vehicle on page 19.**
2. Disconnect the battery cables, negative (–) cable first, as shown (**Figure 5**).
3. Disconnect the spark plug wire(s) from the spark plug(s).

## SIDE-POST BATTERY: CONNECTING THE BATTERY-GASOLINE VEHICLES

1. Connect the battery cables, positive (+) cable first.
2. Tighten battery terminals to 80 in·lb (9 N·m).
3. Coat terminals with Battery Terminal Protector Spray (CC P/N 1014305) to minimize corrosion.
4. Connect the spark plug wire(s) to the spark plug(s).

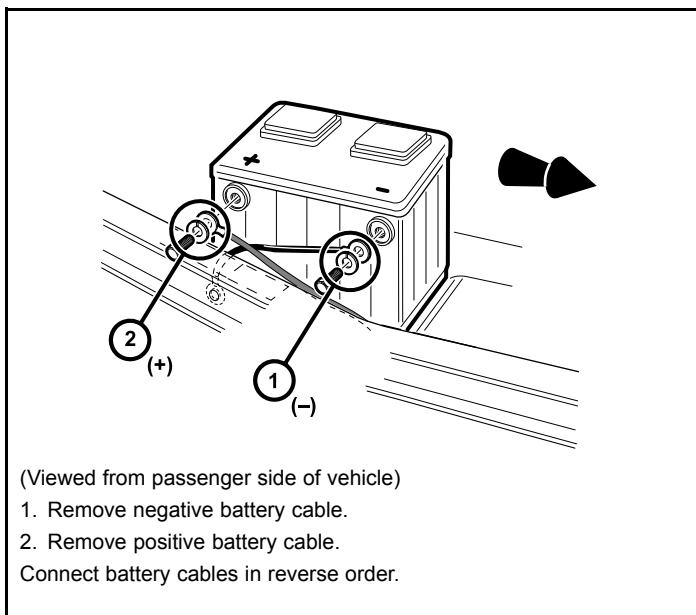

<sup>1</sup> Figure 5 Side-Post Battery – Battery Cable Removal – Gasoline Vehicle

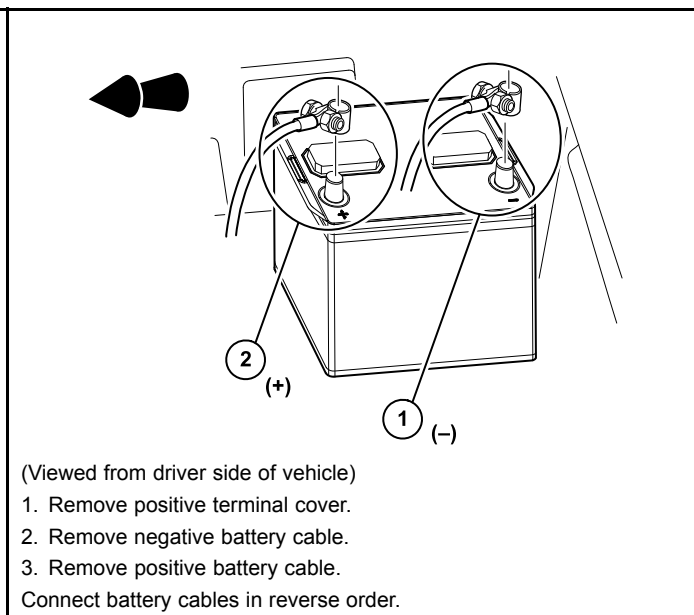

Figure 6 Top-Post Battery- Battery Cable Removal-Gasoline Vehicles

## TOP-POST BATTERY: DISCONNECTING THE BATTERY-GASOLINE VEHICLES

1. Disable the vehicle. **See Disabling the Vehicle on page 19.**
2. Remove positive terminal cover,.
3. Disconnect the battery cables, negative (-) cable first, as shown (Figure 6).
4. Disconnect the spark plug wire(s) from the spark plug(s).

## TOP-POST BATTERY: CONNECTING THE BATTERY-GASOLINE VEHICLES

1. Connect the battery cables, positive (+) cable first.
2. Tighten battery terminals to 41 in·lb (4.3 N·m).
3. Coat terminals with Battery Terminal Protector Spray (CC P/N 1014305) to minimize corrosion.
4. Attach positive terminal cover.
5. Connect the spark plug wire(s) to the spark plug(s).

## RECYCLING LEAD-ACID BATTERIES

### **⚠ WARNING**

- Lead-acid batteries contain lead (Pb), other metals, acids and other compounds. If improperly handled, they can contaminate both water and soil, causing environmental damage and personal injury.

Lead-acid batteries are identified by the symbol shown below and should be properly recycled (**Figure 7**). They cannot be disposed as municipal waste and must be collected separately. Responsibility for environmental protection must be shared, not only by the manufacturers of the batteries, but by people who use the batteries as well. Please contact your nearest Club Car dealer or distributor for information on how to properly recycle your batteries.

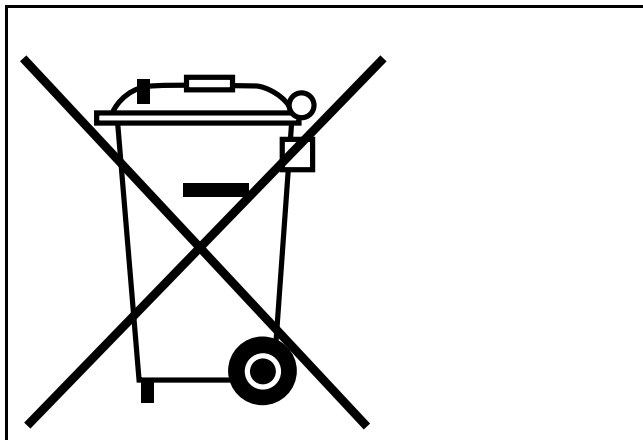

1403

**Figure 7 Dispose of Lead-acid Batteries Properly**

## INTERNATIONAL SAFETY SYMBOLS ON BATTERIES

Anyone using, repairing, or servicing the vehicle must understand and heed the safety symbols on the vehicle battery or batteries.



|   |   |                          |
|---|---|--------------------------|
| 1. Shield eyes.                                 | 3. No smoking, no open flames, no sparks. | 5. Battery acid hazard.  |
| 2. Read and follow operating instructions.      | 4. Keep away from children.               | 6. Explosive gas hazard. |
| Refer to General Warnings for more information. |   |                          |

1642

**Figure 8 International Safety Symbols on Batteries**

## GENERAL INFORMATION

This manual features Carryall 500, 550, and 700 electric and gasoline vehicles. Electric Carryall 500, 550, and 700 vehicles are equipped with IQ Plus electrical systems and onboard Delta-Q QuiQ™ battery chargers. Gasoline Carryall

500, 550, and 700 vehicles are equipped with Subaru engines and accompanying powertrains and are available with a pedal-start (standard) or key-start (optional) configuration.

Throughout this manual, important features unique to each model are highlighted. We urge the owner/operator to read and understand this manual, and to pay special attention to the features specific to their vehicle(s).

## CARRYALL 550 WHEELS

Carryall 550 front and rear wheels are NOT interchangeable. The front wheels have no offset, whereas the rear wheels do have an offset. A rectangular sticker on the inside of each wheel designates its correct position on the vehicle as either FRONT (front) or REAR (rear).

### **⚠ WARNING**

- Installing the wrong wheel can reduce vehicle stability and cause serious injury or death.

## MODEL IDENTIFICATION

---

The serial number of each vehicle is printed on a bar code decal mounted below the center dash panel (Example: CC5819-123456) (**Figure 9**).

The two letters (1) at the beginning of the serial number indicate the vehicle model. The following four digits (2) indicate the model year and production week during which the vehicle was built. The six digits (3) following the hyphen represent the unique sequential number assigned to each vehicle built within a given model year. **See following NOTE.**

**NOTE:** Have the vehicle serial number available when ordering parts or making inquiries.

**Build Code:** The build code (4) is a five-digit number that appears on the vehicle serial number decal. The build code exists to enable the user to identify the correct owner's manual for a vehicle. This owner's manual is valid for the build code range indicated on the back cover of this owner's manual.

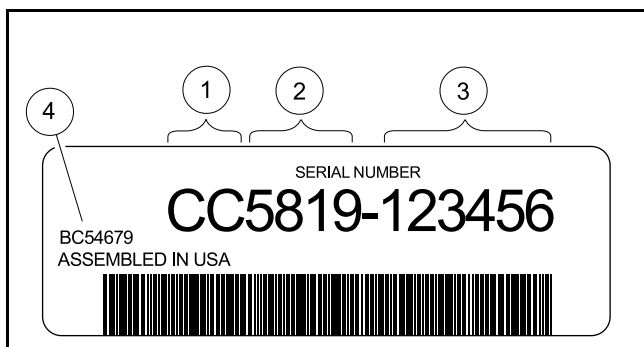

**Figure 9** Serial Number Decal

## CONTROLS AND INDICATORS

---

See General Warnings on page 16.

## **⚠ WARNING**

- **Before allowing anyone to drive the vehicle, make sure the driver is familiar with all controls and operating procedures.**
- **Gasoline vehicles only: Do not tamper with the governor. Doing so will void the warranty, as well as damage the engine and other components, and can result in property damage, personal injury, or death due to unsafe speeds.**

## **KEY SWITCH**

The key switch (1) is mounted on the dash to the right of the steering column (**Figure 10** or **Figure 11**).

Each vehicle is equipped with either a two-position key switch or a three-position key switch. All electric vehicles are equipped with a two-position key switch. Gasoline vehicles equipped with a two-position key switch are referred to as “pedal-start”. Gasoline vehicles equipped with a three-position key switch are referred to as “key-start”.

- **Electric and pedal-start vehicles:** The key switch has two positions: OFF and ON.
- **Key-start vehicles:** The key switch has three positions: OFF, ON and START. To start the vehicle, turn the key past the ON position to the START position and hold until the engine is running smoothly. Release the key and it will return to the ON position and the engine should idle.

## **⚠ WARNING**

- **Moving parts! Keep clear of the engine compartment while the engine is running.**

## **CAUTION**

- **Key-start vehicles: Do not “rev” the engine for long periods of time while the Forward/Reverse handle is in the NEUTRAL position. Failure to heed this caution can result in damage to the unitized transaxle.**
- **Key-start vehicles: Do not shift the Forward/Reverse handle while the accelerator pedal is pressed. Shift the handle only when the vehicle is at a complete stop. Failure to heed this caution can result in damage to the unitized transaxle.**

**NOTE:** *When the key is turned to the OFF position, the main vehicle systems are disabled. The key switch may be used as an emergency shut-off.*

*The key can be removed only when the key switch is in the OFF position.*

## **FORWARD/REVERSE CONTROL**

### **Electric Vehicles**

The Forward/Reverse rocker switch (2) is located at the bottom center of the instrument panel (**Figure 10**). The **F** (FORWARD) and **R** (REVERSE) positions are clearly marked. Press the FORWARD side of the switch to operate the vehicle in the forward direction, or press the REVERSE side of the switch to operate the vehicle in reverse. When the rocker switch is positioned in NEUTRAL, with neither side down, the vehicle will not operate if the accelerator pedal is pressed. Club Car vehicles operate at reduced speed in reverse. The reverse buzzer will sound as a warning when the Forward/Reverse switch is in the REVERSE position.

### **Gasoline Vehicles**

The Forward/Reverse handle (2) is located at the bottom center of the instrument panel (**Figure 11**). The handle has three distinct positions: **F** (FORWARD), **N** (NEUTRAL), and **R** (REVERSE). Push the handle up to operate the vehicle in the forward direction, or pull the handle down to operate the vehicle in reverse.

- **Pedal-start vehicles:** The engine will not run when the handle is in the NEUTRAL position.
- **Key-start vehicles:** The engine will idle while in the NEUTRAL position. The engine must be at idle before shifting the Forward/Reverse handle. **See preceding WARNING and CAUTION.**

Club Car vehicles operate at reduced speed in reverse. The reverse buzzer will sound as a warning when the Forward/Reverse handle is in the REVERSE position.

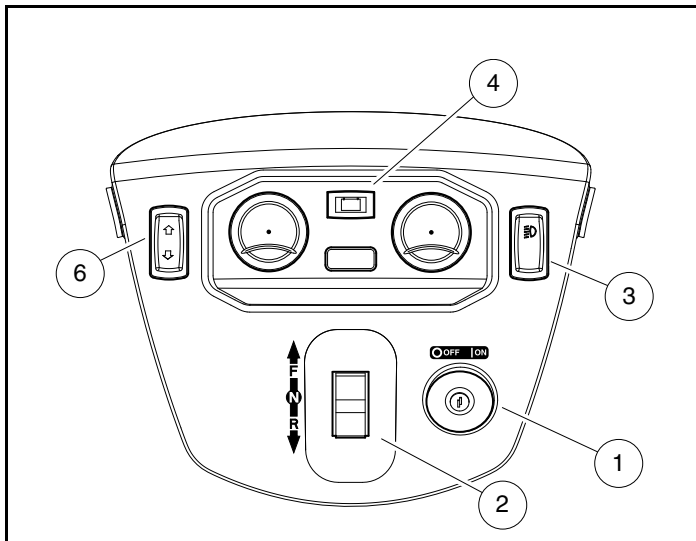

2820

Figure 10 Instrument Panel – Electric Vehicles

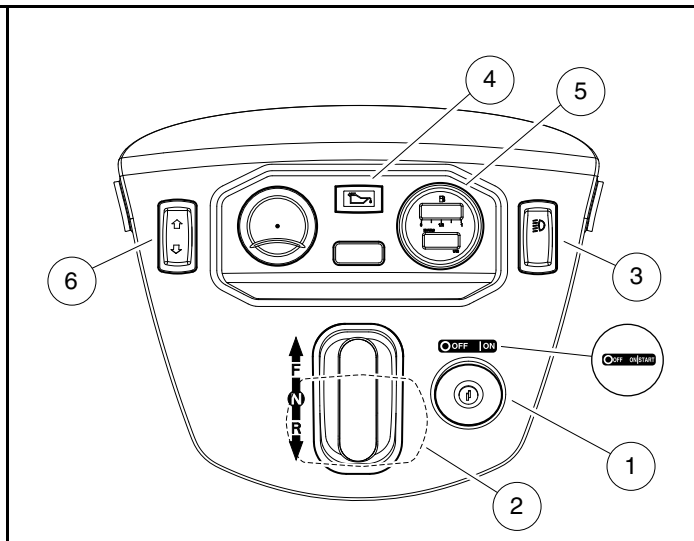

2821

Figure 11 Instrument Panel – Gasoline Vehicles

## HEADLIGHT CONTROL

### Vehicles with Headlights

The headlight switch (3) is located on the right side of the instrument panel (**Figure 10** or **Figure 11**). Press the side of the switch with the headlight symbol to turn the headlights on and press the other side to turn the headlights off.

**NOTE: Gasoline vehicles:** Using the headlights for extended periods of time without the engine running or with the engine idling will discharge the battery.

## CHARGE INDICATOR LIGHT

### Electric Vehicles Only

The electric vehicle features a charge indicator light (4) located at the top of the instrument panel (**Figure 10**). The light serves two functions: 1) Battery low state-of-charge warning, and 2) Charging confirmation.

### Battery Low State-of-Charge Warning

- The light comes on and remains solid when the battery state of charge falls below 20%.
- The light begins flashing when the battery state of charge falls below 10%.

## CAUTION

- **When the light indicates a low state of charge, the vehicle should be placed on charge as soon as possible.**

### Charging Confirmation

- The light will flash three times and the reverse buzzer simultaneously will sound three times to indicate a battery charging session has begun.

## LOW OIL WARNING LIGHT

### Gasoline Vehicles Only

The gasoline vehicle is equipped with a low oil warning light (4), located at the top of the instrument panel (**Figure 11**). If the warning light comes on, oil should be checked and added to the engine as necessary before continuing to use the vehicle. **See following CAUTION.** The vehicle should never be driven when the low oil warning light remains on. If the warning light goes on and off, the vehicle may be driven, but oil should be added at the first opportunity. The light will flash repeatedly to indicate a possible problem with the electronic fuel injection (EFI) system. If the oil level is correct and the warning light stays on, have a trained technician check the vehicle.

## CAUTION

- Failure to add oil immediately when the low oil warning light stays on can result in permanent engine damage.

## FUEL GAUGE/HOUR METER (OPTIONAL)

### Gasoline Vehicles Only

If so equipped, the fuel gauge/hourmeter (5) is located on the instrument panel (**Figure 11**). The fuel gauge allows the operator to monitor the fuel level in the vehicle. The hour meter should be used by the trained technician to track vehicle usage and determine when periodic service procedures are required. **See Periodic Service Schedules on page 44.**

## ELECTRIC BED LIFT

**NOTE:** An electric bed lift is standard on the Carryall 700. It is optional on the other models.

**NOTE:** On the Carryall 700, the electric bed lift has a maximum load capacity of 500 lb (226 kg).

For vehicles equipped with an electric bed lift, the electric bed lift switch (6) is located on the upper left side of the instrument panel (**Figure 10**) or (**Figure 11**).

To lift the bed, press the side of the switch with the *up* arrow, and press the other side of the switch to lower the bed. The bed lift will make a loud clicking sound to signal the bed is in the rest position.

## ⚠ WARNING

- Gasoline vehicles: Keep clear of moving parts when bed is in the raised position and the engine is running.
- Keep hands and fingers clear of crush area between the bed and the seat back support.

## 12-VOLT POWER POINT

A 12-volt power point is located in the driver's side dash pocket and is rated at 6.5 amps (**Figure 12**). When the key switch is in the ON position, the power point provides power to accessories plugged into it. The electrical circuit to the power point also powers all additional electrical accessories on the vehicle and is protected by a 10-amp fuse. Exceeding a 10-amp total draw on the circuit will result in a blown fuse.

**NOTE:** The power point circuit is disabled while the battery charger is plugged in.

*The power point is not for continuous use. Extended use can cause the vehicle battery or batteries to become heavily discharged. For gasoline vehicles, do not use the power point for long periods of time when the engine is not running.*

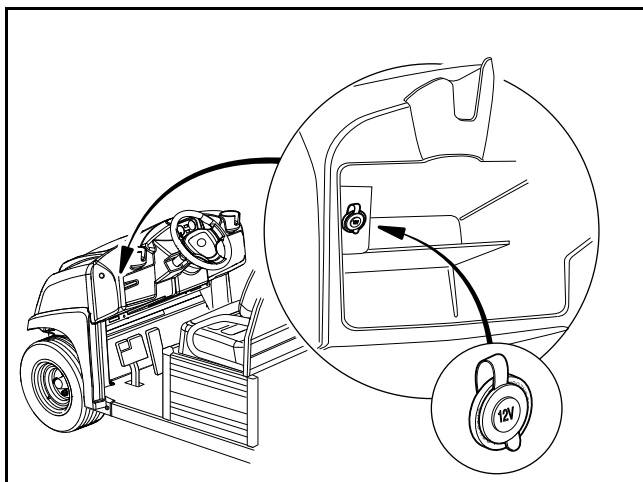

2848

**Figure 12 12-Volt Power Point**

## ACCELERATOR PEDAL

The accelerator pedal is the pedal on the right, with the word GO molded into it (**Figure 13**).

- **Electric and pedal-start vehicles:** When the key switch is in the ON position, and the Forward/Reverse handle or switch is in either the FORWARD or REVERSE position, pressing the accelerator pedal will automatically release the park brake and start the vehicle moving in the direction selected (forward or reverse). When the accelerator is released, power will be cut off and the motor or engine will stop running.
- **Key-start vehicles:** The engine must first be running before shifting the Forward/Reverse handle and pressing the accelerator pedal. Pressing the accelerator pedal will automatically release the park brake and start the vehicle moving in the direction selected. When the accelerator is released, the engine will idle. **See following WARNING and CAUTION.**

### **⚠ WARNING**

- **Moving parts! Keep clear of the engine compartment while the engine is running.**

### **CAUTION**

- **Key-start vehicles: Do not “rev” the engine for long periods of time while the Forward/Reverse handle is in the NEUTRAL position. Failure to heed this caution can result in damage to the unitized transaxle.**
- **Key-start vehicles: Do not shift the Forward/Reverse handle while the accelerator pedal is pressed. Shift the handle only when the vehicle is at a complete stop. Failure to heed this caution can result in damage to the unitized transaxle.**

## Electric Vehicles

Electric vehicles use a special electrical system, which employs motor braking in some modes of operation. In those modes, the vehicle operates as follows:

- **Walk Away Braking:** This feature prevents the vehicle from rolling away uncontrolled should the driver park on a slope and leave the vehicle without locking the park brake. The vehicle will roll at about 1 to 3 mph (1.6 to 4.8 km/h). If the walk away braking function remains engaged for two seconds or more, a warning buzzer will sound to alert the driver that motor braking has been activated. **See following WARNING.**

## **⚠ WARNING**

- **Walk away braking will not limit vehicle speed to 3 mph (4.8 km/h) on very steep grades. Do not operate vehicle on slopes exceeding 20% grades.**
- **Pedal Down Motor Braking:** This feature helps to control vehicle downhill speed. Motor braking is activated when the vehicle reaches the programmed top speed and holds the vehicle at that speed. Motor braking is automatically disengaged when vehicle speed slows below the programmed top speed.
- **Pedal Up Motor Braking:** Speed settings are programmable for IQ Plus vehicles. Motor braking is activated when the accelerator pedal is released at or above the programmed speed. When the vehicle slows to the programmed lower speed, motor braking will disengage. If no speed settings are programmed, motor braking will be activated at any time accelerator pedal is released, and it will only disengage when the vehicle comes to a stop. Contact your dealer/distributor to inquire about this programmable feature.

## **⚠ WARNING**

- **When batteries are fully charged, a warning buzzer will sound during motor braking to alert the driver that motor braking is operating at a reduced level of performance. When this occurs, use the brake pedal to control vehicle speed.**

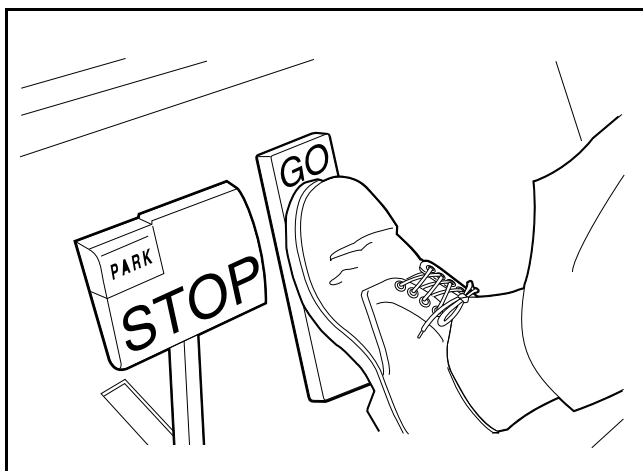

77

Figure 13 Accelerator and Brake Pedals

## **BRAKE PEDAL**

The brake pedal is the large pedal on the left with the word STOP molded into it (**Figure 13**). To slow or stop the vehicle, press the brake pedal with your right foot (**Figure 14**).

## **PARK BRAKE PEDAL**

The park brake pedal is the small raised portion in the upper left corner of the brake pedal. It has the word PARK molded into it and the words PARK BRAKE marked on top of it (**Figure 13**). To set the park brake, press the brake pedal firmly and tilt the park brake portion of the pedal forward with your foot (**Figure 15**). **See following WARNING.**

## **⚠ WARNING**

- **The park brake will release automatically when either the accelerator or brake pedal is pressed. The park brake has multiple locking positions and should be firmly pressed and locked to prevent the vehicle from rolling.**

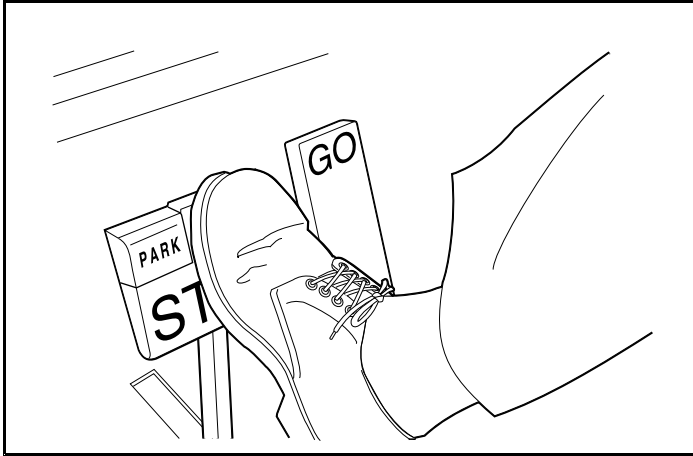

78

Figure 14 Brake Pedal

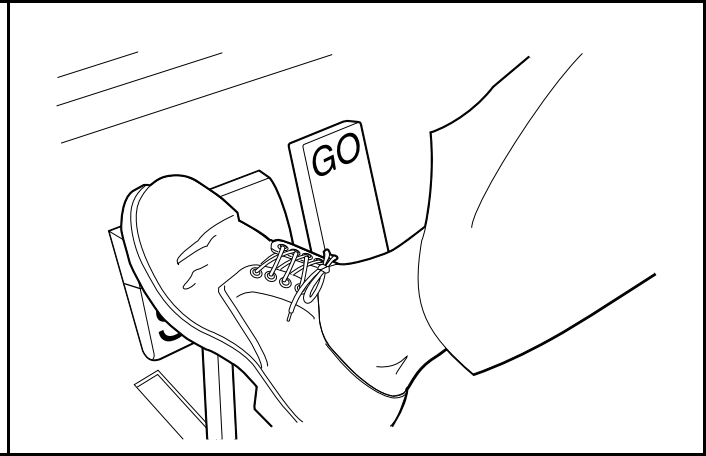

79

Figure 15 Park Brake

## TOW/RUN SWITCH

Electric Vehicles Only

### **⚠ WARNING**

- Place Tow/Run switch in the TOW position before disconnecting or connecting the batteries. Failure to heed this warning can result in a battery explosion or severe personal injury.
- When the Tow/Run switch is in the TOW position, all motor braking functions, including walk-away braking, are disabled.

Electric vehicles are equipped with a Tow/Run switch (1), located on the seat support panel under the seat (**Figure 16**). The switch must be in the RUN position in order to operate the vehicle. When the switch is in the TOW position, power to the vehicle electrical components is turned off and the vehicle will not operate. **See following NOTE.**

**NOTE:** After placing the Tow/Run switch in the TOW position, allow 10 seconds to elapse before switching back to the RUN position.

After placing the Tow/Run switch in RUN position, allow 10 seconds to elapse before operating the vehicle.

The Tow/Run switch should be placed in the TOW position under the following conditions:

- **Before Towing the Vehicle:** Place the Tow/Run switch in the TOW position to disable all motor braking functions, thus preventing possible damage that can occur to the vehicle or electrical components if the vehicle is towed while the walk-away braking function is operating.
- **Before Disconnecting or Connecting Battery Cables:** Place the Tow/Run switch in the TOW position to turn off power to the vehicle electrical system, thus preventing arcing and possible battery explosion as the battery cables are disconnected.
- **For Long Term Storage:** Place the Tow/Run switch in the TOW position to turn off power to the vehicle electrical system, thus preventing vehicle electrical components from discharging the batteries.

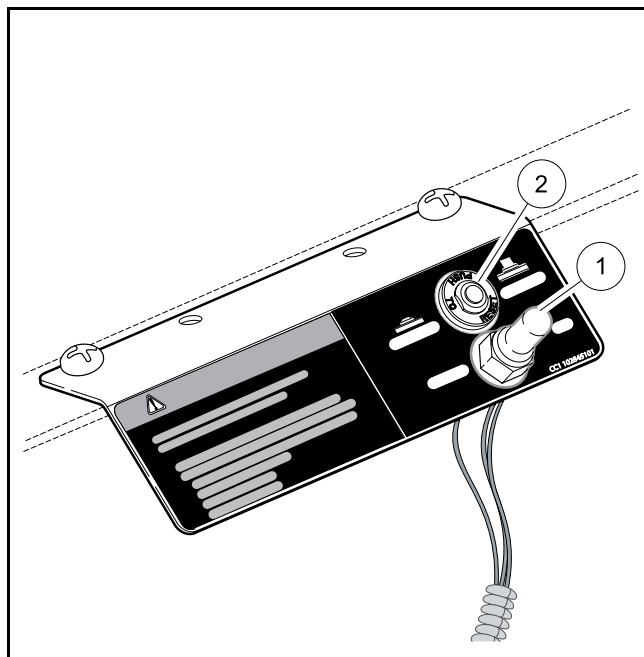

80

Figure 16 Tow/Run Switch

## CIRCUIT BREAKER

### Electric Vehicles Only

IQ Plus vehicles are equipped with a circuit breaker (2), located next to the Tow/Run switch (**Figure 16**). If the circuit breaker has been tripped, a series of rapid beeps will sound and vehicle speed will slow to approximately one-half of its top programmed speed. In the event of a tripped circuit breaker, bring the vehicle to a complete stop, remove seat, and push the breaker to reset. If the circuit breaker trips again when vehicle operation is resumed, contact your local Club Car distributor/dealer.

## NEUTRAL LOCKOUT SWITCH

### Gasoline Vehicles Only

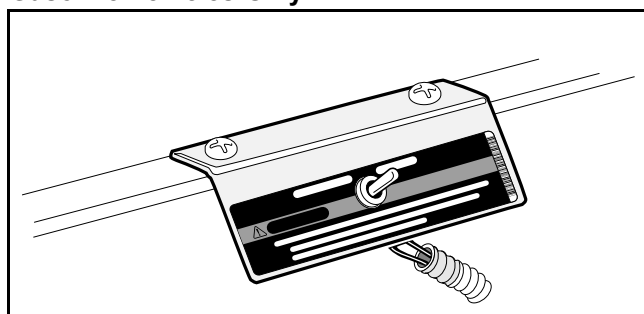

81

Figure 17 Neutral Lockout Switch

For the convenience of the trained technician, there is a neutral lockout switch located on the seat support panel under the seat (**Figure 17**). The neutral lockout switch has two positions, MAINTENANCE and OPERATE, which are clearly marked.

When the switch is in the MAINTENANCE position, it will allow the technician to run the engine in the NEUTRAL position to perform certain maintenance and/or repair functions. With the switch in this position, the vehicle will not operate if the Forward/Reverse handle is placed in either the FORWARD or REVERSE position.

## **⚠ WARNING**

- With the switch in the **MAINTENANCE** position and the engine running, the vehicle can move suddenly if the Forward/Reverse handle is shifted or accidentally bumped. To prevent this, chock the front and rear wheels and firmly set the park brake before servicing or leaving the vehicle.

**NOTE:** Be sure to return the switch to the **OPERATE** position after servicing the vehicle, or it will not run with the Forward/Reverse handle in either the **FORWARD** or **REVERSE** position.

## **BED LATCH**

Carryall 500 and 550 vehicles are equipped with a bed latch on the driver side of the vehicle (**Figure 18**). To lift the bed, lift up on the latch handle, then lift the bed.

To close the bed, lower it gently until the bed latch engages. **DO NOT** drop the bed.

## **⚠ WARNING**

- Keep hands and fingers clear of crush area between the bed and the seat back support.

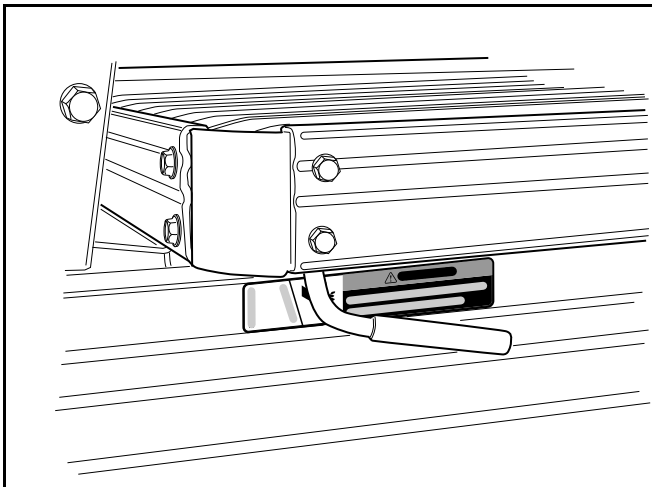

2827

**Figure 18 Bed Latch**

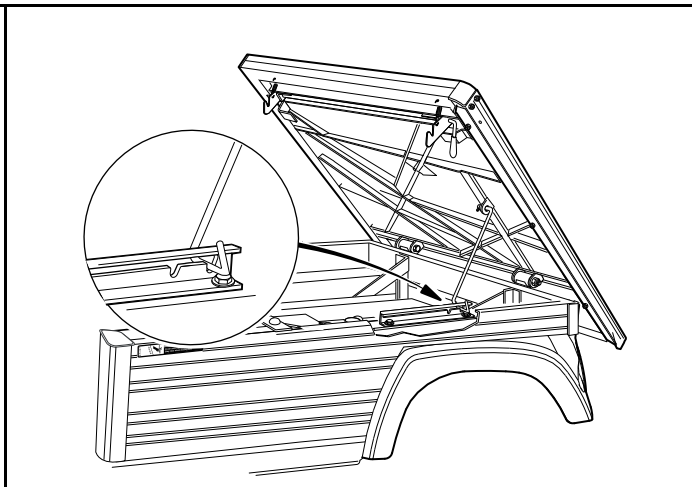

2828

**Figure 19 Prop Rod**

## **PROP ROD**

See **General Warnings** on page 16.

Carryall 500 and 550 vehicles are equipped with an automatically engaging prop rod and prop rod track on the driver side of the rear body (**Figure 19**). When pulling the bed latch handle and lifting the bed, the prop rod will come to rest in one of the notches in the prop rod track.

## **⚠ DANGER**

- Use caution when working under bed. Be sure prop rod is secure. Otherwise the bed will fall, resulting in severe personal injury or death.

## **⚠ WARNING**

- Do not disengage prop rod until all persons are clear of cargo bed area.
- Do not drop tilt bed; lower gently and keep entire body clear. Failure to follow these instructions can result in severe injury.
- Keep hands clear of crush area between bed and seat back support.

To lower the bed of a Carryall 500 or 550 vehicle, lift the bed so that the prop rod is no longer supported in one of the track notches. Push the prop rod toward the front of the vehicle to free it from the track notch and gently lower the bed. DO NOT drop the bed.

## **PRE-OPERATION AND DAILY SAFETY CHECKLIST**

Each Club Car vehicle has been thoroughly inspected and adjusted at the factory; however, upon receiving your new vehicle(s), you should become familiar with its controls, indicators, and operation. Carefully inspect each vehicle to ensure that it is in proper working condition before accepting delivery.

Use the following checklist as a guide to inspect the vehicle. This checklist should be used daily to ensure that the vehicle is in proper working condition and in conjunction with the Performance Inspection on page 32 and the Periodic Service Schedules on page 44. Any problems should be corrected by a Club Car distributor/dealer or a trained technician.

- **General:** All the parts should be in place and properly installed. Be sure that all nuts, bolts, and screws are tight. On gasoline vehicles, check all hose clamps for tight fit as well as the starter belt for tightness.
- **Safety and information decals:** Check to ensure that all safety and information decals are in place. **See Safety Decal Identification on page 5.**
- **Tires:** Visually inspect for wear, damage, and proper inflation on a daily basis. **See Vehicle Specifications on page 69.**
- **Battery(ies):** Check electrolyte to ensure that it is at its proper level (**Figure 23, Page 53 or Figure 30, Page 62**). Check battery posts. Wires should be tight and free of corrosion. On electric vehicles, charge batteries fully before first use of vehicle.
- **Charger cord and plug (electric vehicles):** Visually inspect for cracks, loose connections, and frayed wiring.
- **Side-post Battery (gasoline vehicles):** Check electrolyte to ensure it is at the proper level (**Figure 30, Page 62**). Check battery posts. Wires should be tight and free of corrosion and battery should be fully charged.
- **Top-post Battery (gasoline vehicles):** Check battery posts. Wires should be tight and free of corrosion and battery should be fully charged. (**Figure 31, Page 63**).
- **Engine (gasoline vehicles):** Check for proper engine oil level. **See Engine Oil – Gasoline Vehicle on page 63.** Inspect air intake for blockage.
- **Fuel (gasoline vehicles):** Check fuel level. **See Fueling Instructions – Gasoline Vehicle on page 66.** Check fuel tank, fuel injector, lines, cap, and pump for fuel leakage on a daily basis.
- **Performance Inspection:** Inspect as instructed. **See Performance Inspection on page 32.**

## **WARNING**

- **Be sure the plastic has been removed from the seat bottom before operating the vehicle. Failure to do so can result in a fire, property damage, personal injury, or death.**

## **PERFORMANCE INSPECTION**

After you have familiarized yourself with the vehicle controls and have read and understood the driving instructions, take the vehicle for a test drive.

Use the following checklist, in conjunction with the Pre-Operation and Daily Safety Checklist, as a guide to inspect the vehicle and check daily for proper operation. Any problems should be corrected by a Club Car distributor/dealer or a trained technician.

### **All Vehicles**

- **Forward/Reverse control:** Check for proper operation. **See Controls and Indicators on page 22.**
- **Brakes:** Be sure the brakes function properly. When brake pedal is fully pressed under moderate pressure, it should not go more than halfway to the floor, and vehicle should come to a smooth, straight stop. If the brake pedal goes more than halfway to the floor, or if the vehicle swerves or fails to stop, have the brake system checked and adjusted as required. Brake adjustment must be maintained so that the brake pedal cannot be pressed to the floor under any circumstance.
- **Park brake:** When latched, the park brake should lock the wheels and hold the vehicle stationary (on an incline of 20% or less). It should release when either the accelerator or brake pedal is pressed.
- **Reverse buzzer:** The reverse buzzer should sound as a warning when the Forward/Reverse handle or switch is in the REVERSE position.
- **Steering:** The vehicle should be easy to steer and should not have any play in the steering wheel.
- **General:** Listen for any unusual noises such as squeaks or rattles. Check the vehicle ride and performance. Have a Club Car distributor/dealer or a trained technician investigate anything unusual.

### **Electric Vehicles**

- **Accelerator:** With the key switch in the ON position and the Forward/Reverse switch in the FORWARD position, as the accelerator pedal is pressed, the motor should start and the vehicle should accelerate smoothly to full speed. Club Car vehicles operate at reduced speed in reverse. When the pedal is released, it should return to the original position and the motor should rotate freely or go into motor braking mode. **See Pedal Up Motor Braking below.**
- **Walk Away Braking:** With the vehicle parked on level ground and the park brake disengaged, place the Tow/Run switch in the RUN position and attempt to push the vehicle. Motor braking should engage and limit rolling to no more than 1 to 3 mph (1.6 to 4.8 km/h) with the Forward/Reverse switch in any position. When walk away motor braking is engaged, the reverse buzzer should emit a distinct pattern of beeps.
- **Pedal Up Motor Braking:** Accelerate the vehicle to full speed and then release the accelerator pedal. Motor braking should quickly and smoothly slow the vehicle. Motor braking will disengage when vehicle slows to the programmed speed for IQ Plus vehicles. This feature is programmable for IQ Plus vehicles. Contact your local Club Car dealer/distributor to inquire about this adjustable feature.
- **Pedal Down Motor Braking:** Accelerate down an incline with the accelerator pedal pressed. When the vehicle reaches maximum programmed speed, motor braking should engage and limit the vehicle to its maximum programmed speed. On very steep grades, the vehicle may slightly exceed its maximum programmed speed, requiring use of the brake pedal.

### **Gasoline Vehicles**

- **Accelerator for pedal-start vehicles:** With the key switch in the ON position and the Forward/Reverse handle in the FORWARD position, as the accelerator pedal is pressed, the engine should start and the vehicle should accelerate smoothly to full speed. When the pedal is released, it should return to the original position and the engine should stop.

- **Accelerator for key-start vehicles:** After starting the engine with the key switch and placing the Forward/Reverse handle in the FORWARD position, the vehicle should accelerate smoothly to full speed as the accelerator pedal is pressed. When the accelerator pedal is released, it should return to the original position and the engine should idle.
- **Governor:** Check maximum speed of the vehicle on a level surface. Refer to Vehicle Specifications beginning on page 72 for the rated speed of the vehicle.

## DRIVING INSTRUCTIONS

### **▲ WARNING**

- Only licensed drivers should be allowed to drive the vehicle.
- Before allowing anyone to drive the vehicle, make sure the driver is familiar with all controls and operating procedures.
- No more than two people should be in the vehicle at one time.
- Do not allow riders in the cargo bed.
- The vehicle is not specially equipped for handicapped persons. Be sure all persons can properly operate the vehicle prior to allowing them to drive the vehicle.
- Be sure all passengers are capable of securing themselves in a vehicle before allowing them to ride in one.
- For night use, the vehicle must be equipped with headlights, taillights, and reflectors.
- Stop the vehicle before shifting the Forward/Reverse handle or switch. Failure to do so can result in injury to inattentive passengers and (or) damage to the vehicle.
- Do not leave children unattended in vehicle at any time.
- To help avoid being struck, do not stand in front of or behind the vehicle.
- Operate the vehicle from the driver seat only.
- To help prevent falls from the vehicle, remain seated in a moving vehicle and hold on to hand holds or handrails at all times. Driver should keep both hands on the steering wheel when the vehicle is in motion.
- To help prevent the possibility of serious injury, keep entire body inside the vehicle.
- To help prevent overturning the vehicle, drive slowly in turns.
- To help prevent overturning the vehicle, drive slowly straight up and down slopes. Avoid driving the vehicle on slopes exceeding 20% incline.
- Avoid stopping a loaded vehicle on a hill. If a loaded vehicle must be stopped on a hill, avoid sudden starts or rolling backwards and stopping suddenly. Failure to heed this warning can result in overturning the vehicle.
- To help avoid possible injury to inattentive passengers and (or) damage to the vehicle, avoid sudden starts, sudden stops, and abrupt turns.
- To help avoid the possibility of losing control of or overturning the vehicle, reduce speed for adverse driving conditions such as wet grass or rough terrain.

WARNING CONTINUED ON NEXT PAGE

## **⚠ WARNING**

- Do not use the vehicle on public roads. It is neither designed nor intended for street use and should not be licensed for use on public roads.
- The vehicle should be driven in only specified areas by trained drivers.
- Do not drive while under the influence of alcohol, drugs, or medications.
- Use brakes to reduce speed when coasting downhill.
- Never attempt jumps.
- This vehicle is not intended to be used where risk of falling objects exists. If your vehicle will be used in such an environment, contact your local dealer.
- Do not drive the vehicle under tree limbs, bridges, tunnels, or other objects that are less than 80 inches (203 cm) from the ground.
- Use caution when operating the vehicle with accessories attached to the bed sides. Accessories can add to the width of the vehicle, increasing the likelihood of striking nearby persons or objects, which can cause damage or personal injury.

No one should drive the vehicle without first being instructed in the proper operation and use of the vehicle's controls. An experienced operator should accompany each first-time driver on a test drive before allowing them to operate the vehicle alone.

To ensure safe operation of the vehicle, follow exactly and in order, all of the following procedures. Read and understand all instructions prior to driving the vehicle.

## **STARTING THE VEHICLE**

1. Read safety and information decals located on the vehicle.
2. Study and understand controls.
3. Make sure load is secure.
4. Make sure everyone is seated and holding onto hand holds or handrails. Driver should have both hands on the steering wheel.
5. Make sure wheels are turned in desired direction and that nothing is obstructing vehicle's path.
6. **Electric and pedal-start vehicles:** Start the vehicle.
  - 6.1. Turn the key to the ON position.
  - 6.2. Select direction by placing the Forward/Reverse handle or switch in the desired position (F = Forward or R = Reverse). A buzzer will sound as a warning when the Forward/Reverse handle or switch is in the REVERSE position.
  - 6.3. Slowly press the accelerator pedal. The park brake will release automatically and the vehicle will start to move. As the accelerator pedal is pressed, speed will increase until full speed is reached. **See following WARNING and NOTE.**
7. **Key-start vehicles:** Start the vehicle.
  - 7.1. Make sure the Forward/Reverse handle is in the NEUTRAL position.
  - 7.2. Press and hold brake pedal.
  - 7.3. Turn the key all the way to the START position and release after the engine has started. The engine will idle with the Forward/Reverse handle in the NEUTRAL position.
  - 7.4. Keeping brake engaged, place the Forward/Reverse handle in desired position (F = Forward or R = Reverse). Engine must be at idle before moving the handle. A buzzer will sound as a warning when the vehicle is in the REVERSE position.

- 7.5. Release brake pedal and slowly press accelerator pedal. The park brake will release automatically and the vehicle will start to move. As the accelerator pedal is pressed, speed will increase until full speed is reached. **See following WARNING and NOTE.**

## **WARNING**

- Operator must control vehicle speed when going downhill.
- Stop the vehicle before shifting the Forward/Reverse handle or switch. Failure to do so can result in injury to inattentive passengers and (or) damage to the vehicle.

### Electric vehicles only:

- Pedal down or pedal up motor braking can be used to help control speed when going downhill; however, steep terrain or other conditions can require that pedal braking be used in conjunction with motor braking.

### Gasoline vehicles only:

- Press the brake pedal as necessary and partially press the accelerator when descending a hill. With the accelerator pedal partially pressed, the governor will cause the engine to assist the brakes in controlling downhill speed.

## STOPPING THE VEHICLE

### **WARNING**

- Driving through water can affect the brakes. After driving through water, check effectiveness of the brakes by gently pressing the brake pedal. If the vehicle does not slow down at the normal rate, continue to press the brake pedal until the brakes dry out and normal performance returns.
- After stopping the vehicle, firmly set the park brake until it is fully engaged and prevents the vehicle from rolling.

### **CAUTION**

- When stopped on a hill, use the brake pedal to hold your position. Do not use the accelerator pedal to hold position.

To stop vehicle, release the accelerator pedal and press the brake pedal until vehicle comes to a complete stop.

## PARKING AND LEAVING THE VEHICLE

1. After coming to a complete stop, engage the park brake until it locks the wheels and prevents the vehicle from rolling.
2. Turn the key switch to the OFF position and place the Forward/Reverse handle or switch in the NEUTRAL position. Remove the key when the vehicle is not in use.

**Electric vehicles only:** When the Tow/Run switch is in the RUN position (with the Forward/Reverse switch or key switch in any position), the walk-away braking function will prevent the vehicle from rolling at more than 1 to 3 mph (1.6 to 4.8 km/h) unless the accelerator is pressed. This prevents the possibility of a parked vehicle (with the park brake disengaged) rolling away too fast to be overtaken on foot.

## LOADING AND UNLOADING

---

### **⚠ WARNING**

- Engage park brake to lock wheels before loading the vehicle.
- Do not allow riders in the cargo bed.
- Do not exceed the rated capacity of the vehicle. Rated capacity is for level surfaces only.
- Overloading can affect vehicle handling or cause component failure, resulting in loss of control of vehicle and possible severe personal injury.
- Reduce vehicle load and speed when driving up or down slopes or on uneven terrain.
- Reduce speed and avoid sudden stops when backing up. Failure to do so can cause the vehicle to overturn or flip over backwards.
- Avoid stopping on a hill when loaded. If you must stop on a hill, avoid sudden starts, or rolling backwards and stopping suddenly. Failure to heed this warning can cause vehicle to overturn, possibly resulting in severe personal injury.
- Do not load the tailgate. The tailgate should be in the upright position and latched securely while the vehicle is in motion.
- To help avoid shifting the vehicle load and possibly overturning the vehicle, avoid sudden starts, sudden stops, and abrupt turns.
- The cargo's center of gravity can affect the handling, steering, and braking of the vehicle. Avoid top-heavy loads. When the vehicle is loaded, reduce speed and drive slowly in turns.
- To help prevent cargo from shifting and possibly injuring a passenger or affecting the vehicle's handling, make sure cargo is well secured.
- Unload cargo bed before raising vehicle with a lift, hoist, or jack.
- Cargo load includes the weight of optional equipment.

Center and secure cargo as far forward as possible in the cargo bed. Do not overload the vehicle. **See the following chart for vehicle capacities.**

## VEHICLE LOAD CAPACITIES

---

### **Occupant Capacity**

The occupant capacity is the maximum allowable weight for occupants (operator and passengers) to operate the vehicle safely.

### **Cargo Capacity**

The cargo capacity is the maximum amount of load that the vehicle can haul in the cargo areas and cargo bed and includes the weight of optional equipment.

### **Trailer Tongue Weight**

Trailer tongue weight is the maximum allowable amount of weight exerted by the trailer tongue onto the trailer hitch.

### Gross Trailer Weight

Gross trailer weight is the combination of the trailer weight and the trailer load weight.

### Vehicle Rated Capacity

The vehicle rated capacity is the maximum amount of weight on the vehicle. This capacity includes the weight of occupants, cargo, bed load, and optional equipment.

### Vehicle Combination Rated Capacity

The vehicle combination rated capacity includes the vehicle rated capacity and gross trailer weight.

### Maximum Gross Vehicle Weight

The maximum gross vehicle weight includes the vehicle weight and the vehicle rated capacity. The stated maximum gross vehicle weight must not be exceeded to maintain safe vehicle operation.

### Maximum Gross Vehicle Combination Weight

The maximum gross vehicle combination weight includes the maximum gross vehicle weight and the gross trailer weight. The stated maximum gross vehicle combination weight must not be exceeded to maintain safe vehicle operation.

Refer to Figure 20 for the following specifications.

|  | <b>Carryall 500 Ele and 4-Wheel Brake Gas</b>              | <b>Carryall 550 Electric and Gas</b>                      | <b>Carryall 700 Electric and Gas</b>                       |
|--|--|---|--|
| <b>A: Occupant Capacity</b>  | 400 lb (181 kg)  | 400 lb (181 kg)   | 500 lb (226 kg)  |
| <b>B: Cargo Capacity (includes cargo, bed load and optional equipment.)</b>                      | 800 lb (363 kg)  | 500 lb (227 kg)   | 1000 lb (454 kg)   |
| <b>C: Maximum Trailer Tongue Weight</b>  | 150 lbf (667 N)  | 150 lbf (667 N)   | 150 lbf (667 N)  |
| <b>D: Maximum Gross Trailer Weight</b>   | 1500 lb (680 kg)   | 900 lb (408 kg)   | 1500 lb (680 kg)   |
| <b>A + B = Vehicle Rated Capacity</b>  | 1200 lb (544 kg)   | 900 lb (408 kg)   | 1500 lb (680 kg)   |
| <b>A + B + D, not to exceed stated Vehicle Combination Rated Capacity</b>                        | 1500 lb (680 kg)   | 900 lb (408 kg)   | 1500 lb (680 kg)   |
| <b>Vehicle Weight</b>  | Electric: 1393 lb (632 kg)<br>Gasoline: 907 lb (411 kg)    | Electric: 1402 lb (636 kg)<br>Gasoline: 942 lb (427 kg)   | Electric: 1475 lb (669 kg)<br>Gasoline: 993 lb (450 kg)    |
| <b>A + B + Vehicle Weight = Maximum Gross Vehicle Weight</b>                                     | Electric: 2593 lb (1176 kg)<br>Gasoline: 2107 lb (956 kg)  | Electric: 2302 lb (1044 kg)<br>Gasoline: 1842 lb (836 kg) | Electric: 2975 lb (1349 kg)<br>Gasoline: 2493 lb (1130 kg) |
| <b>A + B + D + Vehicle Weight, not to exceed stated Maximum Gross Vehicle Combination Weight</b> | Electric: 2893 lb (1312 kg)<br>Gasoline: 2407 lb (1091 kg) | Electric: 2302 lb (1044 kg)<br>Gasoline: 1842 lb (836 kg) | Electric: 2975 lb (1349 kg)<br>Gasoline: 2493 lb (1130 kg) |

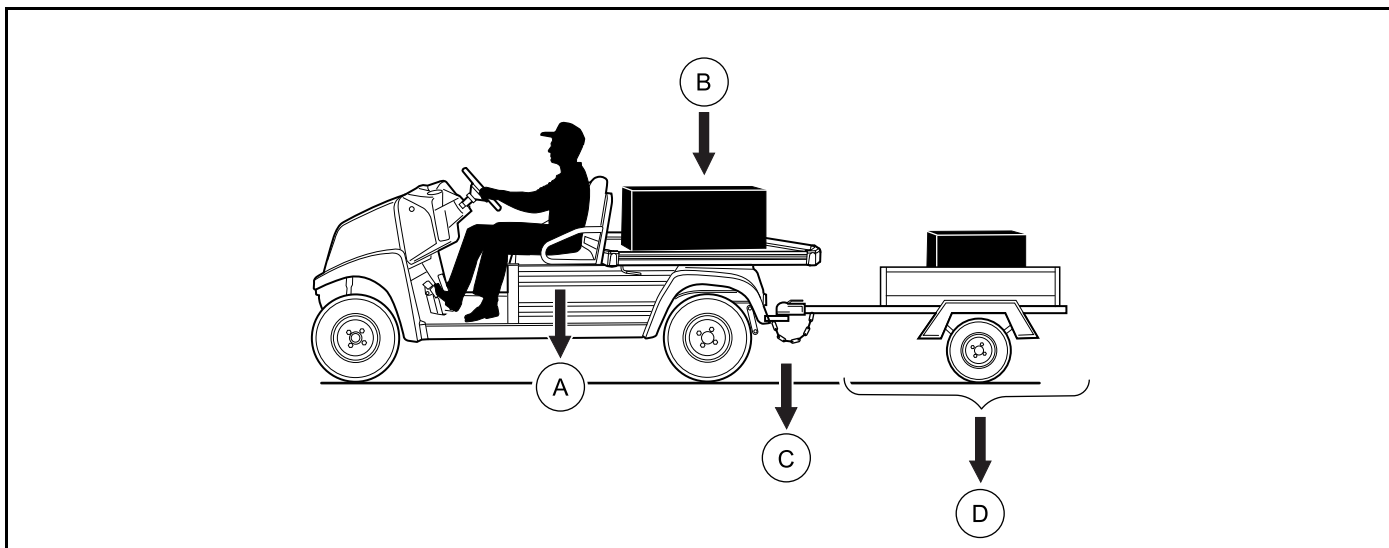

2850

Figure 20 Vehicle Load Capacity

## TOWING WITH THE VEHICLE

### **⚠ WARNING**

- Do not tow a vehicle or trailer on public streets or highways.
- Normal vehicle operating speed should be reduced when towing.
- Extreme caution should be used when towing.
- Maximum gross vehicle combination weight should not exceed the weight previously specified.
- Do not allow riders in the vehicle or trailer being towed.
- Avoid sudden starts, sudden stops, and tight turns when towing.
- Avoid stopping on a hill when towing. If you must stop on a hill, avoid sudden starts or rolling backwards and stopping suddenly. Failure to heed this warning can cause the vehicle to overturn, possibly resulting in severe personal injury.
- Stay clear from the area between the tow vehicle and the towed vehicle or trailer.

Because towing a vehicle or trailer can have an adverse effect on vehicle handling, be especially cautious when towing with a vehicle. **See the preceding chart for vehicle capacities.**

Parking the vehicle with a trailer on a hill should be avoided. If you must park on a hill, apply the brakes and have someone chock the tires of the trailer. Brakes should be released to allow the chocks to absorb the load of the trailer. After the tires have been chocked, engage the park brake.

---

## TRANSPORTING ON A TRAILER

---

### **WARNING**

- Do not allow riders in the trailer being towed.
- Avoid sudden starts, sudden stops, and tight turns when towing.
- Avoid stopping on a hill when towing. If you must stop on a hill, avoid sudden starts or rolling backwards and stopping suddenly. Failure to heed this warning can cause the vehicle to overturn, possibly resulting in severe personal injury.
- For use on public roads, the trailer must meet all federal, state, and local requirements such as taillights, brake lights, etc.
- Reduce normal driving speed when transporting a Club Car vehicle on a trailer.
- Do not tow a Club Car vehicle behind a passenger vehicle or truck on a public road unless it is on an approved trailer.
- The vehicle to be transported should be tied securely to the trailer, with the Forward/Reverse handle or switch in the NEUTRAL position, the key switch in the OFF position, and the park brake engaged to lock wheels.
- Because of the added length of the trailer, use caution when making turns.
- Do not transport the vehicle on a trailer with a load in the vehicle cargo bed.
- Remove the vehicle windshield and secure the seat bottom before transporting on a trailer.
- When trailering the vehicle, make sure the removable front body is correctly installed to prevent separation from the vehicle during transport.

If the vehicle or vehicles must be transported over long distances or on public highways, they should be transported on an approved trailer that has an approved load rating in excess of the weight of the vehicles being transported.

---

## STORAGE – ELECTRIC VEHICLES

---

See General Warnings on page 16.

### **WARNING**

- Turn the key switch to the OFF position, remove the key, and leave the Forward/Reverse handle or switch in the NEUTRAL position during storage. This is to prevent unintentionally starting the vehicle or a fire hazard. Place Tow/Run switch in the TOW position.
- Only trained technicians should service or repair the vehicle or battery charger. Anyone doing even simple repairs or service should have knowledge and experience in electrical and mechanical repair. The appropriate instructions must be used when performing maintenance, service, or accessory installation.
- Do not attempt to charge frozen batteries or batteries with bulged cases. Discard the battery. Frozen batteries can explode.

## **⚠ CAUTION**

- Batteries in a low state of charge will freeze at low temperatures.
- To avoid exposing electrical components to moisture and subsequent damage, do not use any type of pressure washing or steam cleaning equipment to wash the vehicle.

## **PREPARING THE ELECTRIC VEHICLE FOR EXTENDED STORAGE**

### **Check Battery Water Levels Two Weeks Prior to Storage**

Check water levels at least two weeks prior to winter storage to ensure proper mixing of water and electrolyte. Note that it takes approximately five charge cycles with a minimum of 10 amp hours removed after each charge to properly mix the water with electrolyte. Do NOT water batteries immediately prior to storage because this will not provide sufficient charge time to mix the water with the electrolyte. Freezing can occur when batteries are stored in this condition.

1. Check the water levels in each battery cell. If water is required, fill the cells to cover the plates, charge the batteries, and then use distilled water to fill each cell to the correct level. Electrolyte level should be from 1/2 inch (13 mm) above plates to 1/4 inch (6 mm) below the level indicator (**Figure 23**).

### **Immediately Prior to Storage, Perform the Following Steps**

1. Unload the vehicle so that tires are supporting only the weight of the vehicle.
2. Turn the key switch to the OFF position, remove the key, and leave the Forward/Reverse switch in the NEUTRAL position during storage.
3. If so installed, turn off all accessories, including GPS units, fans, etc.
4. Place the Tow/Run switch in the TOW position.

**NOTE:** All functions of the dash-mounted charger information light are disabled when the Tow/Run switch is in the TOW position.

5. Batteries should be clean and free of corrosion. Wash tops and terminals of batteries with a solution of baking soda and water; use 1 cup (237 mL) baking soda per 1 gallon (3.8 L) of water. Rinse solution off batteries. Do not allow this solution to enter the batteries. Let the terminals dry and then coat them with Battery Terminal Protector Spray.
6. Tighten all battery cable connections to 110 in·lb (12.4 N·m).
7. Store vehicle in a cool, dry place. This will minimize battery self-discharge.
8. Adjust tires to recommended tire pressure. **See Vehicle Specifications – Electric Vehicles on page 69.**
9. Perform semiannual periodic lubrication. **See Periodic Lubrication Schedules on page 47.**
10. Thoroughly clean front body, rear body, seats, battery compartment, and underside of vehicle.
11. Do not engage the park brake. Chock the wheels to prevent the vehicle from rolling.

**NOTE:** It is recommended that the vehicles be plugged in and the electrolyte level maintained throughout the storage period. If any of the following conditions exist, however, then disconnect the batteries for storage: 1) The charger cannot remain plugged in, 2) AC power will not be available during extended storage, or 3) Electrolyte levels will not be maintained. To disconnect batteries for storage, go to step 13.

12. To keep batteries fully charged during storage:
  - 12.1. Plug the battery charger into the car. Leave battery chargers plugged in during storage. The charger will automatically activate when necessary.
  - 12.2. Check the electrolyte level and charger function monthly to ensure that proper operation is maintained.

## **CAUTION**

- Be sure to check the batteries and charger monthly to maintain correct battery water level and to ensure the charger is operating correctly during storage.
13. If disconnecting the batteries for storage, disconnect B negative (-) battery cable and secure it in a way that ensures the cable will not come into contact with battery terminal.

## **RETURNING THE STORED ELECTRIC VEHICLE TO SERVICE**

1. If necessary, connect batteries. See **Connecting the Batteries – Electric Vehicles** on page 19.
2. Fully charge batteries.

## **⚠ WARNING**

- Do not attempt to charge frozen batteries or batteries with bulged cases. Discard the battery. Frozen batteries can explode.
3. Adjust tires to recommended tire pressure. See **Vehicle Specifications – Electric Vehicles** on page 69.
  4. Perform the Pre-Operation and Daily Safety Checklist on page 31 and the Performance Inspection on page 32.

## **STORAGE – GASOLINE VEHICLES**

See General Warnings on page 16.

## **⚠ DANGER**

- Do not attempt to drain fuel when the engine is hot or while it is running.
- Be sure to clean up any spilled gasoline before operating the vehicle.
- Store fuel in an approved fuel container only. Store in a well-ventilated area away from sparks, open flames, heaters, or heat sources.
- Keep fuel out of the reach of children.
- Do not siphon fuel from the vehicle.

## **⚠ WARNING**

- Only trained technicians should service or repair the vehicle or battery charger. Anyone doing even simple repairs or service should have knowledge and experience in electrical and mechanical repair. The appropriate instructions must be used when performing maintenance, service, or accessory installation.
- Turn the key switch to the OFF position, remove the key, and leave the Forward/Reverse handle in the NEUTRAL position during storage. This is to prevent unintentionally starting the vehicle or a fire hazard.
- Do not attempt to charge frozen batteries or batteries with bulged cases. Discard the battery. Frozen batteries can explode.

## **⚠ CAUTION**

- Batteries in a low state of charge will freeze at low temperatures.

### **PREPARING THE GASOLINE VEHICLE FOR EXTENDED STORAGE**

1. Unload the vehicle so that tires are supporting only the weight of the vehicle.
2. Store vehicle in a cool, dry place. This will minimize battery self-discharge. If the battery appears to be weak, have it charged by a trained technician. Use an automotive-type 12-volt battery charger rated at 10 amps or less.
3. Seal the fuel tank.
  - 3.1. Fill fuel tank, and, following manufacturer's directions, add a commercially available fuel stabilizer (such as Sta-Bil®).
  - 3.2. Disconnect fuel vent line from fuel tank vent nipple.
  - 3.3. Plug the fuel tank vent nipple so that it is air tight. We recommend using a slip-on vinyl cap.

**NOTE:** It is not necessary to drain the fuel line.

4. Disconnect battery and spark plug wire(s). **See Side-Post Battery: Disconnecting the Battery-Gasoline Vehicles on page 19.**  
**See Top-Post Battery: Disconnecting the Battery-Gasoline Vehicles on page 20.**
5. Batteries should be clean and free of corrosion. Wash tops and terminals of batteries with a solution of baking soda and water: use 1 cup (237 mL) baking soda per 1 gallon (3.8 L) of water. Rinse solution off batteries. Do not allow this solution to enter the batteries. Let the terminals dry and then coat them with Battery Terminal Protector Spray.
6. To protect the engine, remove spark plug and pour 0.5 fl-oz (14.2 mL) of SAE 10 weight oil into the engine through the spark plug hole. Rotate engine crankshaft by hand several times and then install the spark plug and tighten it to 20 ft·lb (27 N·m).
7. Adjust tires to recommended tire pressure. **See Vehicle Specifications on page 69.**
8. Perform semiannual periodic lubrication. **See Periodic Lubrication Schedules on page 47.**
9. Thoroughly clean front body, rear body, seats, cargo bed, engine compartment, and underside of vehicle.
10. Do not engage the park brake. Chock the wheels to prevent the vehicle from rolling.

### **RETURNING THE STORED GASOLINE VEHICLE TO SERVICE**

1. Restore fuel system to operation.
  - 1.1. Remove plug from the fuel tank vent (**Figure 35**).
  - 1.2. Connect vent tube to fuel tank vent.
2. Connect battery and spark plug wire(s). **See Side-Post Battery: Connecting the Battery-Gasoline Vehicles on page 20.**  
**See Top-Post Battery: Connecting the Battery-Gasoline Vehicles on page 20.**
3. Place the Forward/Reverse handle in the NEUTRAL position and the neutral lockout switch in the MAINTENANCE position. Crank the engine until the engine starts. Turn the engine off and return the neutral lockout switch to the OPERATE position. **See following NOTE.**

**NOTE:** Due to the oil added to the engine in preparation for storage, engine may smoke excessively for a short time when it is run for the first time after storage.

4. Adjust tires to recommended tire pressure. **See Vehicle Specifications – Gasoline Vehicles on page 72.**
5. Perform the Pre-Operation and Daily Safety Checklist on page 31 and the Performance Inspection on page 32.

---

## MAINTENANCE

---

See General Warnings on page 16.

To ensure trouble-free vehicle performance, it is very important to follow an established preventive maintenance program. Regular and consistent vehicle maintenance can prevent vehicle downtime and expensive repairs that can result from neglect. Use the Pre-Operation and Daily Safety Checklist on page 31 and the following *Periodic Service Schedules* and *Periodic Lubrication Schedules* to keep the vehicle in proper working condition.

Any vehicle not functioning correctly should be removed from use until it is properly repaired. This will prevent further damage to the vehicle and avoid the possibility of injury due to unsafe conditions.

Contact your local Club Car distributor/dealer to perform all repairs and semiannual and annual periodic service.

### **▲ WARNING**

- If any problems are found during scheduled inspection or service, do not operate the vehicle until repairs are made. Failure to make necessary repairs can result in fire, property damage, severe personal injury, or death.
- Only trained technicians should service or repair the vehicle or battery charger. Anyone doing even simple repairs or service should have knowledge and experience in electrical and mechanical repair. The appropriate instructions must be used when performing maintenance, service, or accessory installation.
- Do not work on vehicle powertrain or under the cargo bed when it is loaded.
- Do not wear loose clothing or jewelry, such as rings, watches, chains, etc., when servicing the vehicle.
- Turn the key switch to OFF, remove the key, place the Forward/Reverse handle or switch in the NEUTRAL position, and chock tires prior to servicing.
- Do not close bed until all persons are clear of the bed area. Lower the bed gently, keeping entire body clear. Do not drop the bed. Failure to follow these instructions can result in severe personal injury.

#### Electric vehicles:

- Hot! Do not attempt to service hot motor. Attempting to do so can cause severe burns.
- To avoid unintentionally starting the vehicle, disconnect the batteries and discharge the controller. See *Disconnecting the Batteries – Electric Vehicles* on page 19.

#### Gasoline vehicles only:

- Moving parts: Do not attempt to service gasoline vehicle while the engine is running.
- Hot! Do not attempt to service hot engine or exhaust system. Failure to heed this warning can result in severe burns.
- To avoid unintentionally starting the vehicle, disconnect battery and spark plug wire(s). See *Side-Post Battery: Disconnecting the Battery-Gasoline Vehicles* on page 19. See *Top-Post Battery: Disconnecting the Battery-Gasoline Vehicles* on page 20.
- Frame ground – Do not allow tools or other metal objects to contact frame when disconnecting batteries or other electrical wiring. Never allow a positive wire to touch the vehicle frame, engine, or other metal component.

## PERIODIC SERVICE SCHEDULES

See General Warnings on page 16.

### **⚠ WARNING**

- Service, repairs, and adjustments must be made per instructions in the maintenance and service manual.

**NOTE:** If the vehicle is constantly hauling heavy loads or hauling a trailer, these preventive maintenance procedures should be performed more often than recommended in the Periodic Service Schedule.

Both the Periodic Service Schedules and the Periodic Lubrication Schedules must be followed to keep vehicle in optimum operating condition.

| PERIODIC SERVICE SCHEDULE – ELECTRIC VEHICLES                                       |   |  |
|---|---|--|
| REGULAR INTERVAL  | SERVICE   |  |
| Daily service by owner  | Pre-Operation and Daily Safety Checklist  | See Pre-Operation and Daily Safety Checklist on page 31.   |
|   | Performance Inspection  | See Performance Inspection on page 32.   |
|   | Batteries   | Charge batteries (after each daily use only).  |
| Weekly service by owner   | Batteries (For vehicles NOT equipped with the Single-Point Watering System)   | Check electrolyte level. Add water if necessary. See page 53.  |
| Monthly service by owner or trained technician                                      | Batteries (For vehicles equipped with the Single-Point Watering System). Water monthly or according to the established watering interval. | Water the batteries. Observe that water flow occurs and no water overflows from any cell. See <b>Battery Care – Vehicles Equipped with the Single-Point Watering System (SPWS) on page 51.</b> |
|   | Batteries   | Wash battery tops and clean terminals with baking soda/water solution.   |
|   | Tires   | Check air pressure and adjust if necessary. See <b>Vehicle Specifications – Electric Vehicles on page 69.</b>  |
|   | General vehicle   | Wash battery compartment and underside of vehicle.   |
| Initial (one-time) inspection by owner or trained technician after six weeks of use | Batteries (For vehicles newly equipped with the SPWS)   | For vehicles newly equipped with the SPWS, manually check battery electrolyte levels of all cells to verify correct valve operation. See page 52.  |

TABLE CONTINUED ON NEXT PAGE

| PERIODIC SERVICE SCHEDULE – ELECTRIC VEHICLES   |   |   |
|---|---|---|
| REGULAR INTERVAL  | SERVICE   |   |
| Semiannual service by trained technician only (or every 50 hours of operation, whichever comes first) | Brake system                                    | Check brake shoes; replace if necessary or adjust as required.  |
|   |   | Check brake cables for damage; replace if necessary.  |
|   |   | Check brake cable equalizer adjustment; adjust if necessary.  |
|   | Electrical wiring and connections               | Check for tightness and damage.   |
|   | Front wheel alignment and camber                | Check and adjust as required. <b>See Steering and Front Suspension section in the maintenance and service manual.</b> |
|   | Motor Controller Output Regulator (MCOR)        | Check for loose hardware, cracks, or other damage.  |
| Annual service by trained technician only (or every 100 hours of operation, whichever comes first)    | Batteries (For vehicles equipped with the SPWS) | Manually check battery electrolyte levels of all cells to verify correct valve operation. <b>See page 52sied.</b>     |
|   | Batteries                                       | If batteries are not performing as expected, see the Batteries section in the maintenance and service manual.         |
|   | Safety decals                                   | Check safety decals. Replace if damaged or illegible.   |

| PERIODIC SERVICE SCHEDULE – GASOLINE VEHICLES  |  |   |
|--|--|---|
| REGULAR INTERVAL                               | SERVICE                                  |   |
| Daily service by owner                         | Pre-Operation and Daily Safety Checklist | <b>See Pre-Operation and Daily Safety Checklist on page 31.</b>   |
|  | Performance Inspection                   | <b>See Performance Inspection on page 32.</b>   |
| Monthly service by owner or trained technician | Engine                                   | Check engine oil level; change if necessary. <b>See Periodic Lubrication Schedules on page 47.</b> Dispose of used oil properly.      |
|  |  | Check engine cooling air intake; visually inspect unshrouded area around engine exhaust for grass and debris, and clean if necessary. |
|  | Tires                                    | Check air pressure and adjust if necessary. <b>See Vehicle Specifications – Gasoline Vehicles on page 72.</b>                         |
|  | General vehicle                          | Wash engine compartment and underside of vehicle. Do not wash engine when hot.  |

TABLE CONTINUED ON NEXT PAGE

| PERIODIC SERVICE SCHEDULE – GASOLINE VEHICLES   |   |   |
|---|---|---|
| REGULAR INTERVAL  | SERVICE   |   |
| Semiannual service by trained technician only (or every 50 hours of operation, whichever comes first) | Battery   | Clean terminals and wash dirt from casing; For side-post battery check electrolyte level ( <b>Figure 29</b> ).            |
|   | Front wheel alignment and camber                      | Check and adjust if necessary.<br><b>See Steering and Front Suspension section in the maintenance and service manual.</b> |
|   | Electrical wiring and connections                     | Check for tightness and damage.   |
|   | Brake system  | Check brake shoes; replace if necessary or adjust as required.  |
|   |   | Check brake cables for damage; replace as required.   |
|   |   | Check brake cable equalizer adjustment; adjust if necessary.  |
| Annual service by trained technician only (or every 100 hours of operation, whichever comes first)    | Engine  | Check for leaks around gaskets, fill plugs, etc.  |
|   |   | Inspect, clean and gap spark plug; replace if necessary.  |
|   | Engine air intake system                              | Check air filter element; clean or replace if necessary.  |
|   |   | Check clamps for tightness; check hose for cracks.  |
|   | General vehicle                                       | Check for loose hardware and tighten if necessary.  |
| Safety decals   | Check safety decals. Replace if damaged or illegible. |   |
| Two-year service by trained technician only.  | Engine  | Check and adjust valve lash as needed.  |

** WARNING**

- If any problems are found during scheduled inspection or service, do not operate the vehicle until repairs are made. Failure to make necessary repairs can result in fire, property damage, severe personal injury, or death.

## PERIODIC LUBRICATION SCHEDULES

| PERIODIC LUBRICATION SCHEDULE – ELECTRIC VEHICLES   |  |                    |   |
|---|--|--------------------|---|
| REGULAR INTERVAL  | SERVICE  | LUBRICATION POINTS | RECOMMENDED LUBRICANT   |
| Semiannually by owner or trained technician (or every 50 hours of operation, whichever comes first) | Brake pedal shaft bearings                         | 1                  | Dry Moly Lube (CC PN 1012151)                                     |
|   | Brake linkage and pivots                           | 2                  | Dry Moly Lube (CC PN 1012151)                                     |
|   | Accelerator pivot rod supports                     | 3                  | Dry Moly Lube (CC PN 1012151)                                     |
|   | Brake slides                                       | 4                  | Dry Moly Lube (CC PN 1012151)                                     |
|   | Front suspension                                   | 5                  | Chassis Lube – EP NLGI Grade 2                                    |
| Annually by trained technician only (or every 100 hours of operation, whichever comes first)        | Transaxle: Check/fill to plug level.               | 6                  | 22 fl-oz (0.67 L) SAE 30 WT. API Class SE, SF, SG Oil (or higher) |
|   | Inspect front wheel bearings (Repack as necessary) | 7                  | Chassis Lube – EP NLGI Grade 2                                    |

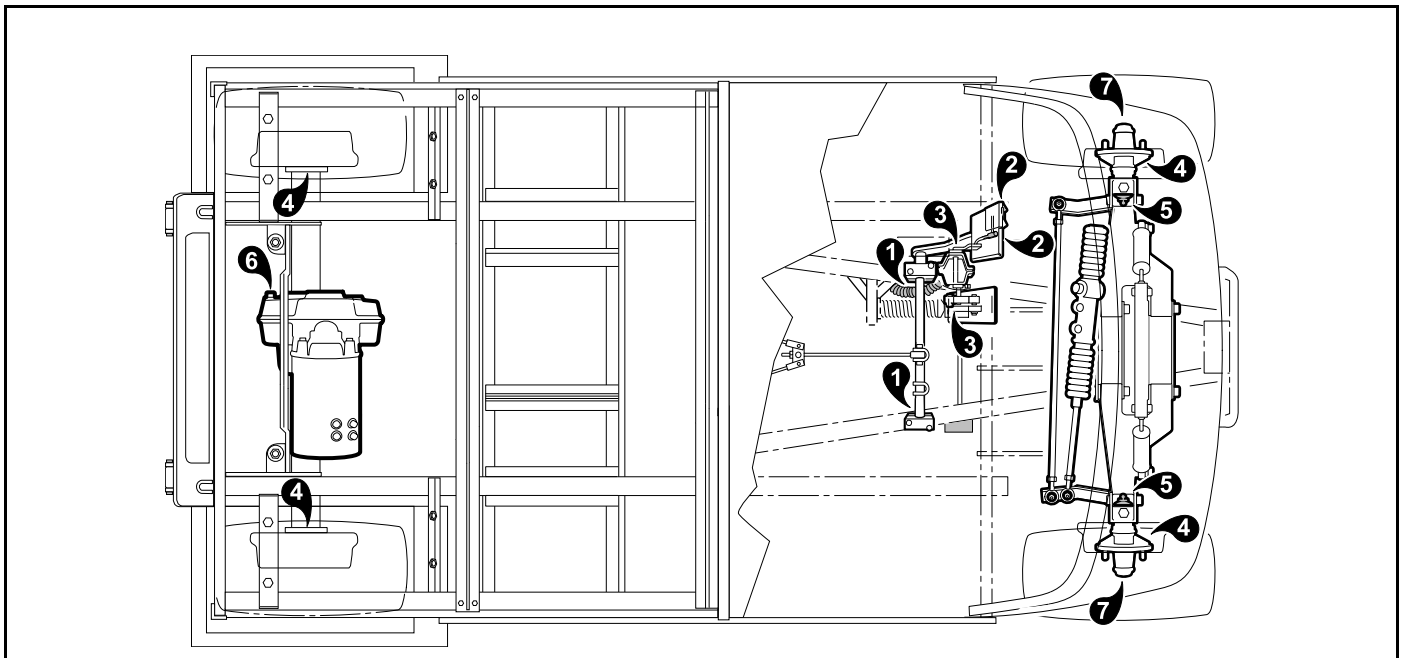

2822

Figure 21 Lubrication Points – Electric Vehicles

| PERIODIC LUBRICATION SCHEDULE – GASOLINE VEHICLES  |   |                    |   |
|--|---|--------------------|---|
| REGULAR INTERVAL   | SERVICE   | LUBRICATION POINTS | RECOMMENDED LUBRICANT   |
| Semiannually by owner or trained technician (or every 50 hours of operation, whichever comes first)        | Brake pedal shaft bearings                              | 1                  | Dry Moly Lube (CC PN 1012151)   |
|  | Brake linkage and pivots                                | 2                  | Dry Moly Lube (CC PN 1012151)   |
|  | Accelerator pivot rod supports and shifter cable pivots | 3                  | Dry Moly Lube (CC PN 1012151)   |
|  | Front suspension  | 4                  | Chassis Lube (EP NLGI Grade 2)  |
|  | Brake slides  | 5                  | Dry Moly Lube (CC PN 1012151)   |
| Annually by trained technician only (or every 100 hours of operation, whichever comes first)               | Transaxle: Check/fill to plug level                     | 6                  | 67.6 fl-oz (2 L) SAE 80W-90 API Class GL-5  |
|  | Inspect front wheel bearings (Repack as necessary)      | 7                  | Chassis Lube – EP NLGI Grade 2  |
| First change 100 hours – additional change every 200 hours of operation or annually, whichever comes first | Change engine oil                                       | 8                  | 40.5 fl-oz (1.2 L) 10W-30 or 5W-30 grade SE or higher<br>See also Figure 34, Page 66. |

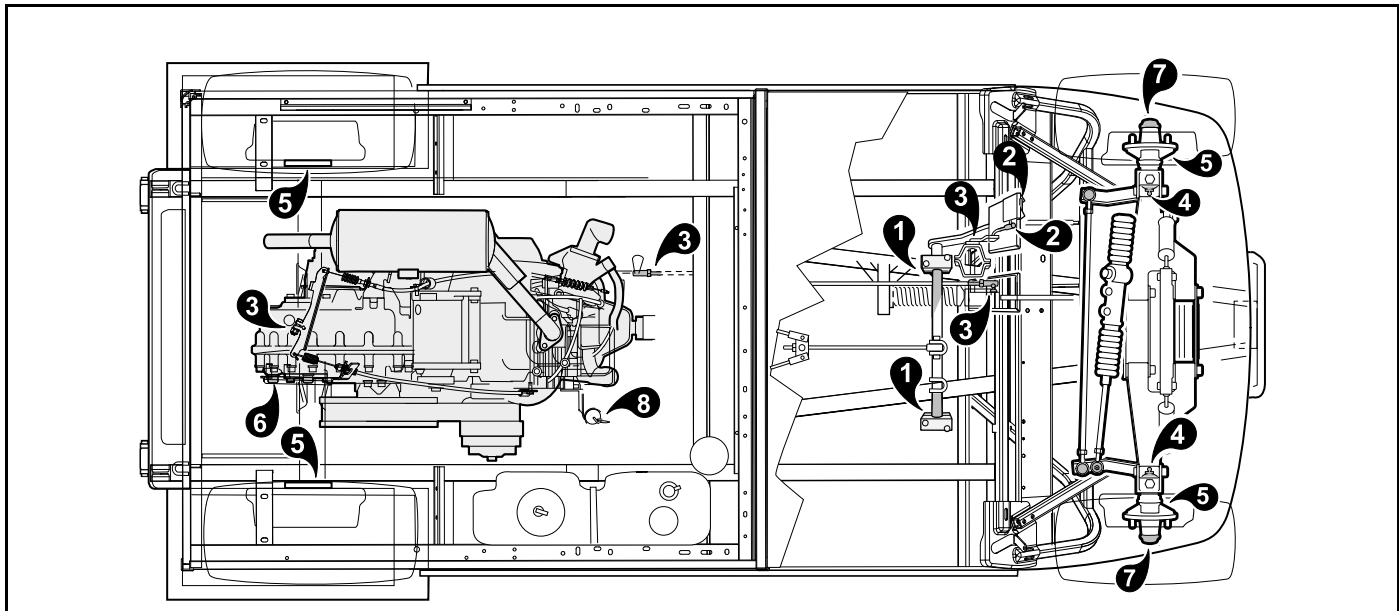

2823  
Figure 22 Lubrication Points – Gasoline Vehicles

---

## BATTERIES – ELECTRIC VEHICLES

---

See General Warnings on page 16.

### **⚠ DANGER**

---

- **Battery – Explosive gases! Do not smoke. Keep sparks and flames away from the vehicle and service area. Ventilate when charging or operating vehicle in an enclosed area. Wear a full face shield and rubber gloves when working on or near batteries.**
- **Charge batteries in a well-ventilated area only. Batteries emit hydrogen while being charged. Hydrogen is an explosive gas and must never exceed a level of 2% of the air.**
- **Battery – Poison! Contains acid! Causes severe burns. Avoid contact with skin, eyes, or clothing. Antidotes:**
  - **External: Flush with water. Call a physician immediately.**
  - **Internal: Drink large quantities of milk or water followed with milk of magnesia or vegetable oil. Call a physician immediately.**
  - **Eyes: Flush with water for 15 minutes. Call a physician immediately.**

### **⚠ WARNING**

---

- **Wear safety glasses or approved eye protection when servicing the vehicle or battery charger. Wear a full face shield and rubber gloves when working on or near batteries.**
- **Use insulated tools when working near batteries or electrical connections. Use extreme caution to avoid shorting of components or wiring.**
- **Ensure battery connections are clean and properly tightened. See Battery Care – Vehicles Equipped with the Single-Point Watering System (SPWS) on page 51 or Battery Care – Vehicles Without the Single-Point Watering System (SPWS) on page 52.**
- **Use only 4-gauge (AWG) wires with low-resistance terminals to replace battery wires on IQ Plus models.**

### **CAUTION**

---

- **Turn off all accessories before charging batteries.**

**NOTE:** Recycle or dispose of discarded batteries in accordance with local, state, and federal regulations.

Club Car electric vehicles use deep-cycle batteries. Automotive batteries should never be used in electric vehicles.

New batteries will not deliver their full capabilities until they have been discharged and recharged 50 to 70 times. To obtain maximum service life from new batteries, restrict the use of vehicles with new batteries to one hour of operation between charges for the first two months vehicle is in service. Batteries should be fully charged before first use of new vehicle, before first use of a vehicle after storage, and before releasing vehicle for use each day.

### **WATER QUALITY**

Water purity is the most important factor in the performance and life span of the vehicle batteries. Club Car has, therefore, placed an increased importance on battery maintenance.

Outlined below are four battery watering procedures, grouped into two categories: Preferred and Alternate methods. Club Car recommends the use of a deionizer or distilled water. Alternate methods of reverse osmosis or tap water are allowable but should be avoided since water quality can change from day to day depending on additives, water main leaks, etc.

**Preferred Methods**

- **Distilled Water:** Distilled water is the most common type of water used in batteries. Distilled water is created by boiling water, collecting the steam from the boiling, and allowing the steam to condense back into water. The distilling process results in a water source which is free of minerals that can lead to the degradation of battery performance and life.
- **Deionized Water:** Deionized water is created by inducing electrically charged resins that attract and bind to sodium, calcium, iron, copper, chloride, and bromide ions. The result of this electrical filtering is a purified water, which contains little to no mineral ions. To make sure the deionized water remains at a high quality, replace the filter in the deionizer per the manufacturer’s recommendations.

**Deionizer Systems**

The Service Parts Department at Club Car offers two deionizer systems: one for vehicles equipped with the Single Point Watering System (SPWS), CC PN 104006001, and the other for vehicles without SPWS, CC PN AM10974.

**Alternate Methods**

- **Reverse Osmosis:** Reverse osmosis involves forcing water through a membrane that allows water to pass while trapping solids. The choice of membrane used determines the amount of solids or impurities which get trapped and hence the purity quality of the filtered water. In addition, the usage frequency of the membrane can also contribute to the filtered water quality. Due to the variance in water quality consistency, Club Car recommends the use of the deionizer or distilled water.
- **Tap Water:** While the use of tap water without filtering is an alternate method of battery watering, its use should be limited due to the levels of dissolved minerals and chemicals that can degrade battery performance and life. If unfiltered tap water is used, regular water analyses must be conducted to check for impurities. The following chart lists the maximum allowable minerals, solids, and contaminants in parts per million and their impact on battery performance. Water testing, however, is expensive, and water quality can change from day to day depending on additives, water main leaks, etc. Due to the cost and labor of performing water quality tests, Club Car recommends the use of distilled water or a deionizer.

| IMPURITY                    | ALLOWABLE CONTENT (PARTS PER MILLION) | EFFECTS OF IMPURITY   |
|-----------------------------|---------------------------------------|---|
| Suspended matter            | Trace                                 | -   |
| Total solids                | 100.0                                 | -   |
| Organic and volatile matter | 50.0                                  | Corrosion of positive plates                                |
| Ammonia                     | 8.0                                   | Slight self-discharge of both plates                        |
| Antimony                    | 5.0                                   | Self-discharge, reduces life, lower on-charge voltage       |
| Arsenic                     | 0.5                                   | Self-discharge, can form poisonous gas                      |
| Calcium                     | 40.0                                  | Increase of positive plate shedding                         |
| Chloride                    | 5.0                                   | Loss of capacity in plates, greater loss in positive plates |
| Copper                      | 5.0                                   | Increased self-discharge, lower on-charge voltage           |

TABLE CONTINUED ON NEXT PAGE

| IMPURITY  | ALLOWABLE CONTENT (PARTS PER MILLION) | EFFECTS OF IMPURITY                               |
|-----------|---------------------------------------|---|
| Iron      | 3.0                                   | Increased self-discharge, lower on-charge voltage |
| Magnesium | 40.0                                  | Reduced life                                      |
| Nickel    | None allowed                          | Intense lowering of on-charge voltage             |
| Nitrates  | 10.0                                  | Increased sulfation of negative plate             |
| Nitrites  | 5.0                                   | Plate corrosion, loss of capacity, reduced life   |
| Platinum  | None allowed                          | Violent self-discharge, lower on-charge voltage   |
| Selenium  | 2.0                                   | Positive plate shedding                           |
| Zinc      | 4.0                                   | Slight self-discharge of negative plates          |

## BATTERY CARE – VEHICLES EQUIPPED WITH THE SINGLE-POINT WATERING SYSTEM (SPWS)

To keep batteries in good working condition, follow this maintenance program on a regular basis:

1. Keep the batteries clean and free of corrosion. Wash tops and terminals of batteries with a solution of baking soda and water; use 1 cup (237 mL) baking soda per 1 gallon (3.8 L) of water. Rinse solution off of the batteries. Do not allow this solution to enter the battery. Be sure terminals are tight. Let the terminals dry and then coat with Battery Terminal Protector Spray. **See following NOTE.**

**NOTE:** *Dispose of waste water properly.*

2. The battery hold-downs should be tight enough so that the batteries do not move while the vehicle is in motion, but not so tight as to crack or buckle the battery case. Tighten hold-down retaining nuts to 55 in·lb (6.2 N·m). The terminal connections should be clean and tight, and any worn insulation or frayed wires should be replaced. Tighten battery terminals to proper torque. **See Connecting the Batteries – Electric Vehicles on page 19. See following WARNING.**

### **⚠ WARNING**

- **If battery wire terminals are damaged or corroded, replace or clean them as necessary. Failure to do so can cause them to overheat during operation and can result in fire, property damage, or personal injury.**
3. After use, charge the batteries. The batteries should never be left discharged any longer than absolutely necessary (do not leave discharged overnight).
  4. Water the batteries monthly or according to the watering interval. **See Establishing the Watering Interval for New Vehicles on page 52. See Watering Batteries with the SPWS on page 59.**

### **CAUTION**

- **The watering interval must adequately maintain the electrolyte level above the top of the plates (Figure 23, Page 53).**
- **Water the batteries only AFTER charging.**

**NOTE:** *Bottled distilled water, with the hand pump, CC PN 104006101, is recommended for private consumer SPWS applications.*

### Establishing the Watering Interval for New Vehicles

If you do not already have a battery watering interval for your vehicles, manually check the battery water level weekly to establish the correct watering interval. Thereafter, water batteries according to the established interval. During periods of heavy use, add additional watering as required.

### Single-Point Watering System (SPWS) Maintenance

1. For vehicles newly equipped with the Single-Point Watering System, the initial electrolyte level check on all battery cells verifies that all the valves in the SPWS are functioning correctly. **See Periodic Service Schedules on page 44.** If a valve fails to open, the cell will eventually dry out. The initial one-time inspection of all cells will identify any occurrence of a valve that fails to open. If a valve fails to close, it will become evident due to the cell overflowing during routine watering. Either failure scenario is rare, but should be monitored in the initial inspection and during routine watering sessions. Replace malfunctioning valves to ensure maximum battery life. **See following CAUTION.**

## **CAUTION**

---

- **After checking the electrolyte, fully tighten the battery caps to prevent electrolyte leakage.**
2. After the initial six-week inspection, manually check the electrolyte level at least once per year, particularly after long-term storage or any other period of vehicle inactivity. **See preceding CAUTION.**

### BATTERY CARE – VEHICLES WITHOUT THE SINGLE-POINT WATERING SYSTEM (SPWS)

To keep batteries in good working condition, follow this maintenance program on a regular basis:

1. Keep the batteries clean and free of corrosion. Wash tops and terminals of batteries with a solution of baking soda and water; use 1 cup (237 mL) baking soda per 1 gallon (3.8 L) of water. Rinse solution off of the batteries. Do not allow this solution to enter the battery. Be sure terminals are tight. Let the terminals dry and then coat with Battery Terminal Protector Spray. **See following NOTE.**

**NOTE:** *Dispose of waste water properly.*

2. Check the electrolyte level weekly (**Figure 23**). Add water only **after** charging unless the electrolyte level is below the top of the plates. In this case, add just enough water to cover the plates, charge, and then check the level again. Never charge batteries if plates are exposed above electrolyte level. For best battery life, add only distilled water. **See following CAUTION.**

## **⚠ CAUTION**

---

- **Do not overfill the batteries.**
3. The battery hold-downs should be tight enough so that the batteries do not move while the vehicle is in motion, but not so tight as to crack or buckle the battery case. Tighten hold-down retaining nuts to 55 in·lb (6.2 N·m). The terminal connections should be clean and tight, and any worn insulation or frayed wires should be replaced. Tighten battery terminals to proper torque. **See Connecting the Batteries – Electric Vehicles on page 19.** **See following WARNING.**

## **⚠ WARNING**

---

- **If battery wire terminals are damaged or corroded, replace or clean them as necessary. Failure to do so can cause them to overheat during operation and can result in fire, property damage, or personal injury.**
4. After use, charge the batteries. The batteries should never be left discharged any longer than absolutely necessary (do not leave discharged overnight).

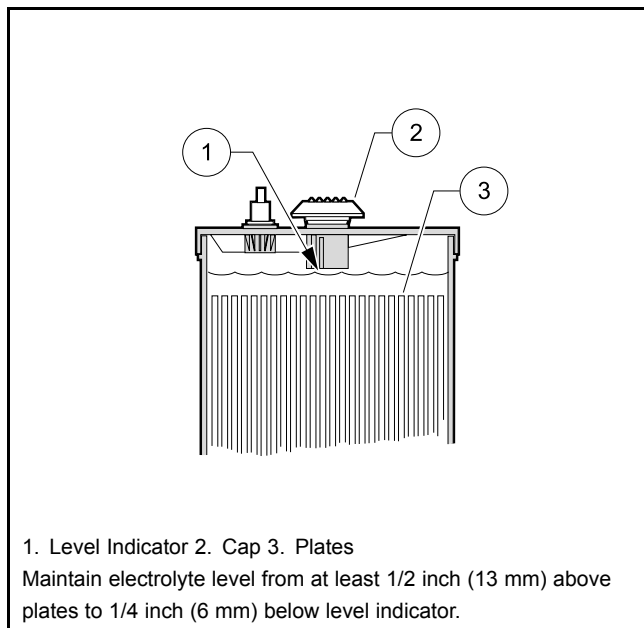

17

Figure 23 Electric Battery Electrolyte Level

## BATTERY CHARGER, QuiQ™ – ELECTRIC VEHICLE

### **⚠ DANGER**

- **Battery – Explosive gases! Do not smoke. Keep sparks and flames away from the vehicle and service area. Ventilate when charging or operating vehicle in an enclosed area. Wear a full face shield and rubber gloves when working on or near batteries.**
- **The charging area must be ventilated. Hydrogen level in the air must never exceed 2%. The total volume of air in the charging area must be changed five times per hour. Exhaust fans should be located at the highest point of the roof. Contact a local HVAC engineer.**
- **Do not charge the vehicle batteries with the vehicle covered or enclosed. Any enclosure or cover should be removed or unzipped and pulled back when batteries are being charged. An accumulation of hydrogen gas can result in an explosion.**
- **If equipped with a cab, do not charge the vehicle batteries with the cab closed. The cab should have windows or doors open when batteries are being charged. An accumulation of hydrogen gas can result in an explosion.**
- **Risk of electric shock. Connect charger power cord to an outlet that has been properly installed and grounded in accordance with all local codes and ordinances. A grounded outlet is required to reduce risk of electric shock; do not use ground adapters or modify plug.**
- **Do not touch uninsulated portion of output connector or uninsulated battery terminals.**
- **Disconnect the AC supply before making or breaking the connections to the battery.**

DANGER CONTINUED ON NEXT PAGE

## **⚠ DANGER**

- Do not open or disassemble charger.
- Do not operate this charger if the AC supply cord is damaged or if the charger has received a sharp blow, been dropped, or otherwise damaged in any way. Refer all repair work to the manufacturer or qualified personnel.

## **⚠ WARNING**

- Only trained technicians should repair or service the charger. Contact your nearest Club Car distributor/dealer.
- This charger is not intended for use by persons (including children) with reduced physical, sensory or mental capabilities, or lack of experience and knowledge, unless they have been given supervision or instruction concerning use of the charger by a person responsible for their safety. Children should be supervised to ensure that they do not play with the charger.
- Do not attempt to charge frozen batteries or batteries with bulged cases. Discard the battery in accordance with all environmental laws or return to an authorized Club Car dealer. Frozen batteries can explode.
- Each charger should have its own dedicated 15 or 20 ampere separately protected (circuit breaker or fuse) single phase branch circuit, in accordance with all applicable electrical codes for the location.
- Connect the charger AC supply cord to a properly grounded, three-wire outlet of the proper voltage and frequency as shown on the charger.
- Do not use an adapter to plug the charger with a three-prong plug into a two-prong outlet. Improper connection of the equipment-grounding conductor can result in a fire or an electrical shock.
- Use only an appropriately sized AC power cord. See AC Power Connection on page 57.
- Do not use near fuels, grain dust, solvents, thinners, or other flammables. Chargers can ignite flammable materials and vapors.
- Prior to servicing the charger, disconnect the AC power supply cord from the wall outlet and remove the battery charger from the vehicle. See removal procedure in the appropriate maintenance and service manual.
- Do not use a battery charger if the cord or plug is damaged in any way. Replace worn or damaged parts immediately. Failure to heed this warning can result in a fire, property damage, severe personal injury, or death.
- Do not operate the charger if it has received a sharp blow, was dropped, or otherwise damaged in any way.
- Have worn, cut, or damaged power cords or wires replaced immediately.
- Install surge arrestors on incoming AC power lines. Surge arrestors will help protect electrical components in the charger and on the vehicle from all but direct or close lightning strikes.
- Ensure battery connections are clean and properly tightened.
- Wear safety glasses or approved eye protection when servicing the vehicle or battery charger. Wear a full face shield and rubber gloves when working on or near batteries.
- Do not wear loose clothing or jewelry such as rings, watches, chains, etc., when servicing the vehicle or battery charger.

WARNING CONTINUED ON NEXT PAGE

## **⚠ WARNING**

- Use insulated tools when working near batteries or electrical connections. Use extreme caution to avoid shorting of components or wiring.
- Do not cover the charger cooling fins. Do not allow clothing, blankets, or other material to cover the charger. The fins dissipate heat and protect the charger from overheating.
- Cooling fins will become hot during charging. Do not touch. Use the handle.

## **CAUTION**

- The battery charger provided with this vehicle is approved for use only with the battery type originally shipped with the vehicle. Using a different battery type (different brand, different capacity, etc.) can cause under or overcharging and subsequent battery damage unless the charger is first reprogrammed with a new charging algorithm. Club Car only recommends OEM replacement batteries. Contact your authorized Club Car dealer/distributor with any questions about battery and charger compatibility or algorithm updates.

## **GENERAL CHARGER INFORMATION**

The QuiQ high-frequency battery charger functions as an integral part of the vehicle electrical system and will not work with other electric vehicles that use different electrical systems. The charger is pre-programmed with a specific charge algorithm that is appropriate to the specific battery type used in the vehicle. When the charger is connected, LED lights on the charger perform a start-up self-test (LEDs light up in sequence). **See Charger Display on page 57.**

As long as the charger is allowed to shut off by itself, the batteries will be fully charged. Overcharging and undercharging will normally be prevented.

### **Features**

- Charge Interlock

When the AC power cord is inserted into a wall receptacle, the charger locks out the vehicle drive system. This prevents the possibility of driving the vehicle while the charger is plugged in and potentially damaging the vehicle and charger.

- Long-Term Storage Charge

Club Car chargers are designed to be left connected with AC power to the charger during off-season or long-term storage. **See Preparing the Electric Vehicle for Extended Storage on page 40.**

### **UL and CSA Listing**

When operated on a 120 VAC 60 Hz, this battery charger has been listed by UL and by the Canadian Underwriters and meets the criteria of the Canadian Standards Association.

### **CE Compliance**

This battery charger is compliant with the EU EMC Directive 2004/108/EC.

### **IP (Ingress Protection) Rating**

The charger has been tested successfully to EN60529, meeting IP66. The AC supply inlet is rated to IP20, which is suitable for indoor use only. Keep all AC connections clean and dry.

### **Charger Power Connection Fuse**

The vehicle charger power circuit has an in-line 30-amp fuse located near the solenoid.

### **AC Input Voltage Detection**

The QuiQ charger automatically detects the AC input voltage and will operate at full power if the voltage is within the 120 to 230 VAC range. The charger also will function outside of that range down to 85 VAC and up to 265 VAC although charging times will be longer. Outside of the 85 to 265 VAC range, the charger will not operate.

### **Thermal Cutback**

The QuiQ charger operates at full power in ambient temperatures between 32 °F (0 °C) and 86 °F (30 °C). The charger also will function outside of that range although charging times will be longer.

### How to Identify the Charger Algorithm Number

To see the charger algorithm number, initiate the Algorithm Display Mode. To enter Algorithm Display Mode, take the following steps:

1. Unplug the AC power supply cord from the wall outlet.
2. Place the Tow/Run switch in the TOW position.
3. Disconnect the heavy-gauge black wire from the negative (–) post of battery no. 8.
4. Plug the AC power supply cord into the wall outlet. **See following NOTE.**

**NOTE:** When the charger AC cord is connected, LED lights on the charger perform a start-up self-test (LEDs light up in sequence).

5. After the start-up self-test, the 80% LED will display a series of flashes that represent the algorithm number (**Figure 24**). [Example: Algorithm number 125 is represented as “one flash”, pause, “two flashes”, pause, “five flashes”.] The charger will not repeat this series of flashes. To see the number again, repeat steps 1 and 4 with a 20 second pause between them.

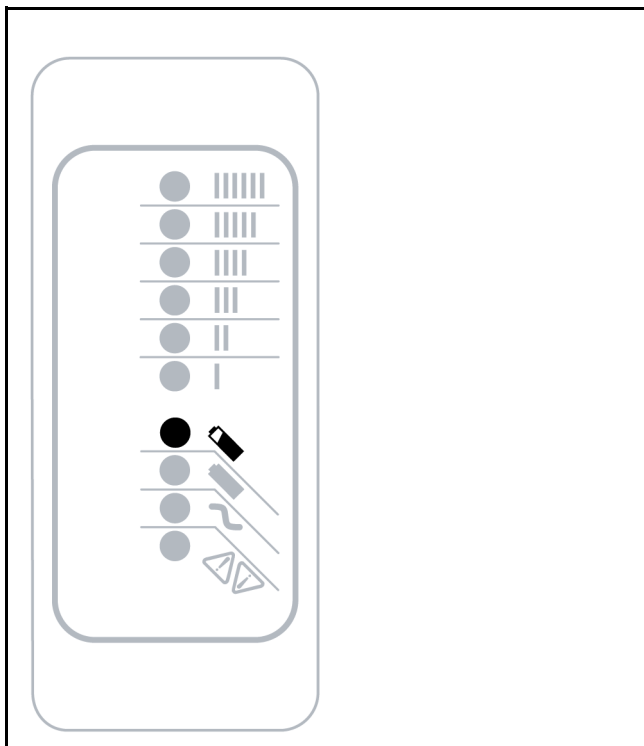
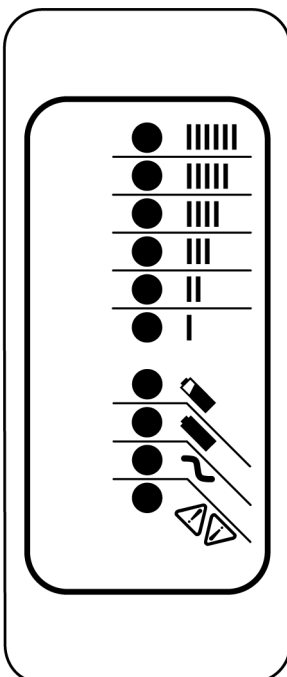







Figure 24 80% LED Flashes in Algorithm Display Mode

## CHARGER OPERATING INSTRUCTIONS

See General Warnings on page 16.

### Charger Display

|  | LED Color          |  | Indication<br>(following the power-on self test)                                  |  |
|--|--------------------|--|---|--|
|  | Ammeter<br>(Amber) |  |  | Solid:   |
| Flashing:  |                    |  |   | High internal charger temperature. Output reduced. Also displays algorithm #1-6 for 11 seconds if no battery is connected. |
| 80% Charge<br>(Amber)  |                    |   | Solid:  | Bulk charge phase complete, 80% charged. In Absorption phase.  |
|  |                    |  | Flashing:   | With no battery connected, indicates algorithm # selected by number of flashes.  |
| 100% Charge<br>(Green)   |                    |   | Solid:  | Charging complete. Charger in Maintenance Mode.  |
|  |                    |  | Flashing:   | Absorption phase complete. In Finish phase.  |
| AC On<br>(Amber)   |                    |   | Solid:  | AC power good  |
|  |                    |  | Flashing:   | Low AC Voltage. Check voltage and power cord length (see above for guidelines).  |
| Fault (Red)  |                    |  | Flashing:   | Charger error. Reset charger power and refer to Troubleshooting Instructions below.  |

### AC Power Connection

#### **CAUTION**

- Charger can be hot during charging. Use hand protection if handling the charger while charging.

**NOTE:** Make sure that the AC cord provided with your charger has the proper AC plug for your location. If it does not, contact your Club Car representative to obtain the proper cord or plug.

Only use **ONE** charger on a single 15 amp circuit, or the circuit may become overloaded. See **QuiQ Battery Charger Specifications on page 70.**

To reduce the risk of electric shock, the battery charger must be grounded. The charger is equipped with an AC electric cord with an equipment-grounding conductor and a grounding type plug. The AC plug must be connected to an appropriate receptacle that is properly installed and grounded in accordance with the National Electric Code and all local codes and ordinances.

The AC power cord must be a three-conductor, no. 12 AWG (American Wire Gauge) or no. 14 SWG (British Standard Wire Gauge), heavy-duty cord with ground, properly wired and in good electrical condition. Keep it as short as possible: no more than 12 feet (3.7 m). Place all cords so they will not be stepped on, tripped over, or otherwise subject to damage or stress.

### Charging Batteries

**NOTE:** Batteries should be put on charge even if they have been used for only a short time, i.e., 10 minutes. The charger is automatic and will turn off when batteries are fully charged. If the charger does not seem to be operating properly, or if the batteries seem weak, contact a local Club Car distributor/dealer.

*New batteries will not deliver their full range until the vehicle has been driven and recharged from 50 to 70 times.*

*Vehicles should be restricted to 40 to 50 amp hours of discharge between charges until the batteries have been properly seasoned (50 to 70 charge cycles). For maximum battery life, Club Car recommends that electric vehicles always be recharged after 40 to 50 amp hours of discharge or each night in order to avoid deep discharging the batteries.*

*When temperatures fall below 65 °F (18.3 °C), batteries charged in unheated areas should be placed on charge as soon as possible after use. Batteries are warmest immediately after use, while cold batteries require more time to fully charge.*

1. Insert the onboard charger AC plug into a dedicated and properly wired AC receptacle to begin a charge cycle. **See QuiQ Battery Charger Specifications on page 70.**

**NOTE:** Only connect **ONE** charger to a single 15 amp circuit, or the circuit may become overloaded.

2. Place the charger AC cord so it will not be stepped on, tripped over, or otherwise subject to damage or stress.
3. Do not place items in the compartment where the battery charger is installed.

After the charger is plugged in, the vehicle's control circuit is locked out, preventing operation of the vehicle as well as the possibility of subsequent damage to the charger and vehicle.

The charger monitors battery voltage, charge current and charge time to determine when the batteries are properly charged. The charger will shut off by itself and the green light will stop flashing and remain on.

The vehicle's control circuit lockout remains activated until the charger AC plug is disconnected from the AC receptacle.

## CHARGER MAINTENANCE

**See General Warnings on page 16.**

To ensure trouble-free performance, it is very important to follow an established preventive maintenance program. Regular and consistent maintenance can prevent vehicle downtime and expensive repairs that can result from neglect.

Any charger not functioning correctly should be removed from use until it is properly repaired. This will prevent further damage to the vehicle and avoid the possibility of injury due to unsafe conditions.

Contact your local Club Car distributor/dealer to perform all repairs and semiannual and annual periodic service.

### **⚠ WARNING**







- **If any problems are found during scheduled inspection or service, do not operate the vehicle until repairs are made. Failure to make necessary repairs can result in fire, property damage, severe personal injury, or death.**
- **Do not wear loose clothing or jewelry, such as rings, watches, chains, etc., when servicing the charger.**
- Do not expose charger to oil, dirt, mud or direct heavy water spray when cleaning vehicle.
- Keep all AC connections clean and dry.
- If the detachable input power supply cord set is damaged, replace with a cord that meets the following criteria:

|                          |  |
|--------------------------|--|
| For North America:       | UL or CSA listed/approved detachable cord, 3 conductor, 16AWG minimum, and rated SJT; terminating in a grounding type IEC 60320 C14 plug rated 250V, 13A minimum.  |
| For all other countries: | Safety approved detachable cord, 3 conductor, 1.5mm <sup>2</sup> minimum, rated appropriately for industrial use. The cord set must be terminated on one end with a grounding type input connector appropriate for use in the country of destination and, on the other end, an output grounding type IEC 60320 C14 plug. |

## CHARGER TROUBLESHOOTING INSTRUCTIONS

See General Warnings on page 16.

If a fault occurs, count the number of red flashes (on the charger) between pauses and refer to the table below:

| RED FLASHES   | CAUSE  | SOLUTION  |
|---|--|---|
|    | Battery High Voltage   | Ensure battery set is rated 48 volts and composed of 24 cells. See Charger Maintenance and Service Manual. If not, replace with correct battery set. Reset charger (interrupt AC power for 15 seconds).   |
|    | Battery Low Voltage  | Ensure battery set is rated 48 volts and composed of 24 cells. Also, check the voltage of each individual battery. See Charger Maintenance and Service Manual. If not, replace with correct battery set. Reset charger (interrupt AC power for 15 seconds). |
|    | Charge Time-out caused by battery pack not reaching required voltage.<br>Charger output was reduced due to high temperatures | Check for loose or corroded connections. Check for old or defective batteries. See Charger Maintenance and Service Manual.<br>Operate charger at a lower ambient temperature.   |
|  | Check Battery: battery could not be trickle charged up to minimum voltage  | Check for shorted or damaged cells. See Charger Maintenance and Service Manual.   |
|  | Over-Temperature: Charger shut down due to high internal temperature.  | Check for dirty, obstructed, or damaged cooling fins. Clean if necessary and ensure sufficient cooling air flow. Reset charger (interrupt AC power for 15 seconds).   |
|  | Charger Internal Fault   | Reset charger (interrupt AC power for 15 seconds).<br>Return to qualified service depot if fault persists.  |

## SINGLE POINT WATERING SYSTEM (SPWS)

### CAUTION

- Water the batteries only **AFTER** charging.
- Use water that meets the quality standards shown on page 49. Maximize battery life by removing ions and heavy metals from water with the use of a deionizer. See Water Quality on page 49.

## WATERING BATTERIES WITH THE SPWS

### Checking the Water Flow Rate

1. Connect the water hose with the built-in screen filter (2) to the water faucet (1) (**Figure 25**). See following **CAUTION**.

## CAUTION

- Make sure the screen filter is clean.
  - Do not use a longer garden hose than provided with the System (20 feet or 6 meters), as a decrease in water pressure can overflow the batteries and damage the refill system.
2. Before screwing the hose-end assembly (3) onto the opposite end of the water hose, check the screen filter (4) inside the end of the assembly to make sure it is clean (**Figure 25**).
  3. Connect the purger (5) to the female coupler (8) on the end of the hose-end assembly (**Figure 26**).

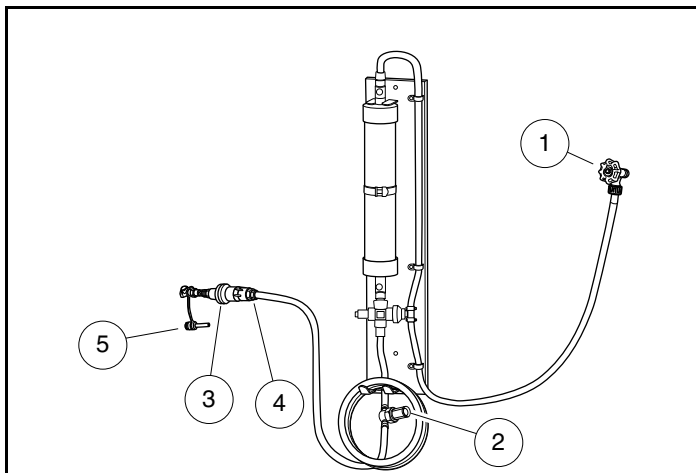

68

**Figure 25** Connecting Hose with Filter to Water Source

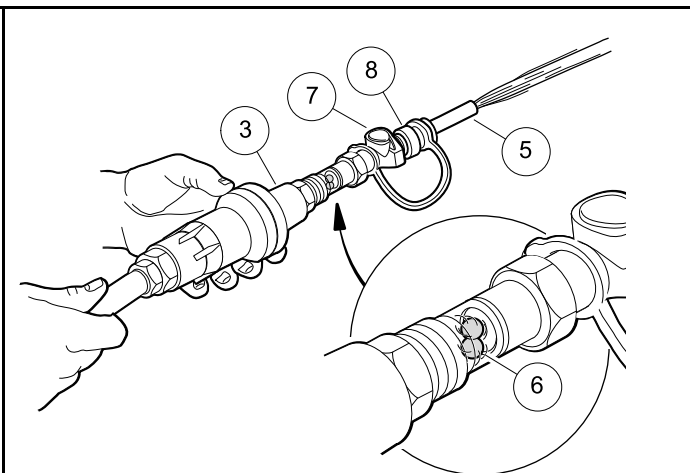

69

**Figure 26** Checking the Water Flow Rate

4. Completely open the water faucet until the water flows out of the hose-end assembly (3), and note the movement of the red flow indicator balls (6). **See following NOTE.**

**NOTE:** This step also eliminates any trapped air from the water hose.

*The water flow rate must be at least 2 gallons per minute (7.6 L per minute) and the water pressure must be no more than 100 psig (689.5 kPa) when static (no flow) for the SPWS to function properly.*

5. Check the water quality light on the deionizer to make sure the light is green in color, indicating acceptable water quality. If the light indicates unacceptable water quality, the cartridge must be replaced.
6. After ensuring adequate water flow rate and water quality, press the grey button (7) on the end of the female coupler (8) to disconnect the purger from the pressure regulator.

### Refilling the Batteries

1. Locate the battery fill coupling (9) on the driver side of the battery compartment, remove the dust cover (10) from the male connector (**Figure 27**), and connect the hose-end assembly (3) (**Figure 28**). The water flow will begin immediately.

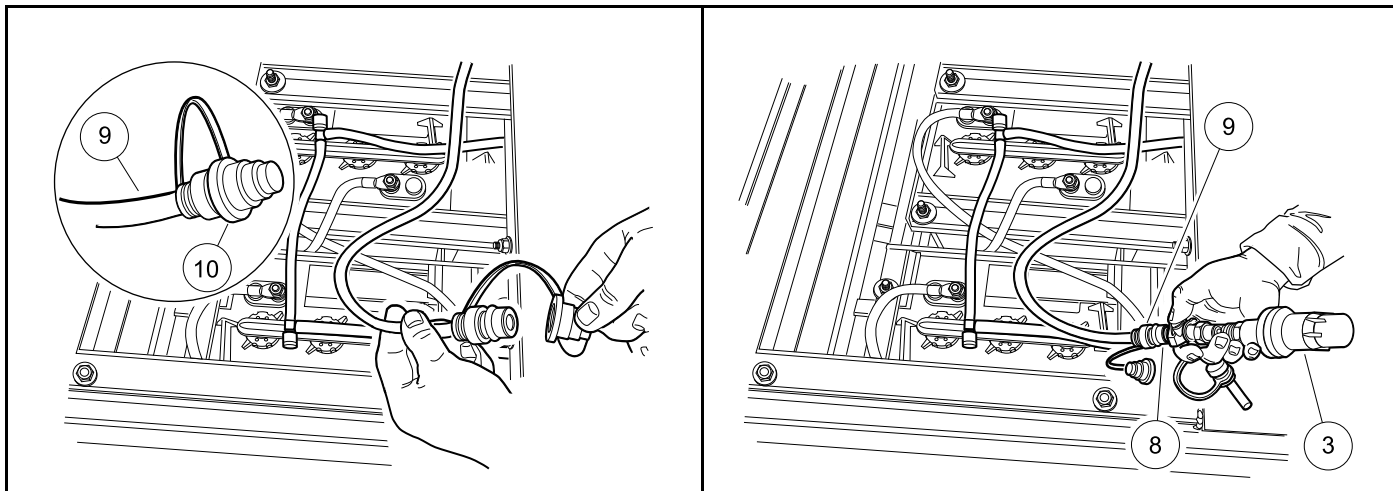

2829

Figure 27 Dust Cap

2830

Figure 28 Connecting Hose-end Assembly to Battery Fill Connector

- The red flow indicator balls should swirl, indicating that the batteries are being filled. **See following CAUTION.**

## **CAUTION**

- If at any time water overflows from the batteries, immediately stop the refill process, disconnect the pressure regulator from the battery fill coupling, and call for service.
- When the red flow indicator balls stop moving, immediately press the grey button to disconnect the hose-end assembly from the battery fill coupling (9), and squeeze the dust cover (10) to lightly secure it to the male connector of the battery fill coupling (Figure 27).
  - Place the battery fill coupling into the space between the batteries and the car body. Leaving the fill coupling on top of the battery bank or tucked between the batteries can result in coupling damage.
  - Turn the water faucet off when finished filling the vehicle(s).

## **BATTERY – GASOLINE VEHICLE**

See General Warnings on page 16.

### **⚠ DANGER**

- Battery – Explosive gases! Do not smoke. Keep sparks and flames away from the vehicle and service area. Ventilate when charging or operating vehicle in an enclosed area. Wear a full face shield and rubber gloves when working on or near batteries.**
- Tools, wires, and metal objects can cause sparks when shorted across a battery.**
- Follow all instructions carefully when working with batteries.**
- Charge battery in a well-ventilated area only.**

**DANGER CONTINUED ON NEXT PAGE**

## **⚠ DANGER**

- **Battery – Poison! Contains acid! Causes severe burns. Avoid contact with skin, eyes, or clothing. Antidotes:**
  - **External: Flush with water. Call a physician immediately.**
  - **Internal: Drink large quantities of milk or water followed with milk of magnesia or vegetable oil. Call a physician immediately.**
  - **Eyes: Flush with water for 15 minutes. Call a physician immediately.**

## **⚠ WARNING**

- **Do not jump-start a dead battery using another battery and jumper cables.**

The battery in a Club Car gasoline vehicle is a 12-volt, side-post or top-post battery. The side-post battery requires infrequent watering. (Figure 30, Page 62).

Any corrosion around the positive (+) or negative (–) terminals should be washed off with a solution of baking soda and water (1 cup (237 mL) per 1 gallon (3.8 L) of water). Rinse solution off the battery. Do not allow this solution to enter battery. Be sure terminals are tight. Let the terminals dry and then spray them with Battery Terminal Protector Spray (CC P/N 1014305). (Figure 29, Page 62) and (Figure 31, Page 63).

See preceding and following WARNINGS.

## **⚠ WARNING**

- **If battery wire terminals are damaged or corroded, replace or clean them as necessary. Failure to do so can cause them to overheat during operation and can result in a fire, property damage, or personal injury.**

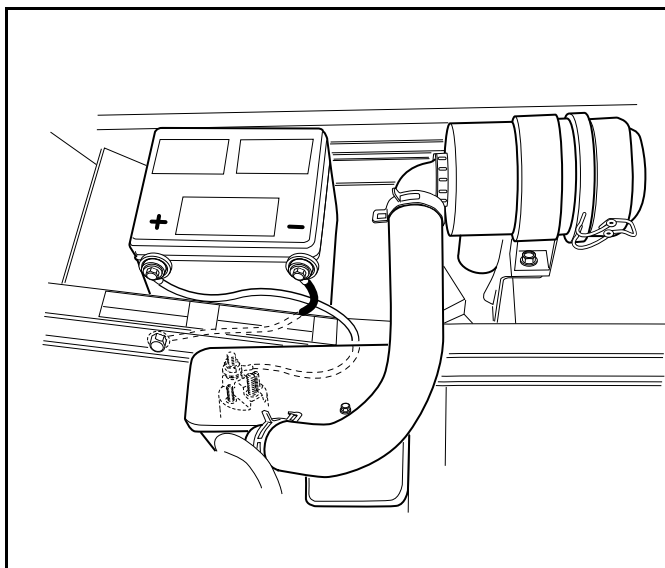

2831

Figure 29 Side-Post Gasoline Vehicle Battery

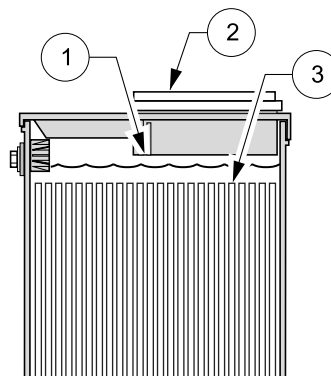

1. Level Indicator 2. Cap 3. Plates

Electrolyte level at least 1/2 inch (13 mm) above plates or to level indicator.

22

Figure 30 Electrolyte Level for Side-Post Battery

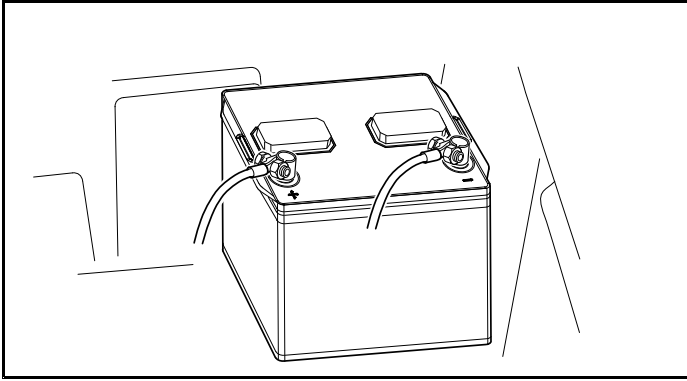

3166

**Figure 31 Top-Post Gasoline Vehicle Battery**

Be sure battery clamp is properly tightened. For Side-Post battery tighten to 80 in·lb (9 N·m). For Top-Post battery tighten to 41 in·lb (4.3 N·m). A loose battery clamp may allow the battery to become damaged from vibration or jarring.

If battery appears weak, have it charged by a trained technician. The battery should never be left discharged any longer than absolutely necessary (do not leave discharged overnight).

## ENGINE OIL – GASOLINE VEHICLE

Even though the low oil warning light on the dash should illuminate if oil level becomes low, engine oil level should be checked monthly. Vehicle should be on a level surface when checking oil. Do not overfill with oil.

### ENGINE OIL LEVEL CHECK

1. Remove the oil level dipstick from the oil filler tube, and wipe oil off dipstick (**Figure 32**). **See following CAUTION.**

#### **CAUTION**

- **Do not remove dipstick while engine is running.**
2. Check oil by fully inserting the dipstick into the oil filler tube and immediately removing it.
  3. If the oil level is at or below the low level mark on the dipstick gauge, add oil until the level is between low and full levels (safe level).
  4. Insert the dipstick into the oil filler tube. **See following NOTE.**

**NOTE:** Properly recycle or dispose of used oil in accordance with local, state, and federal regulations.

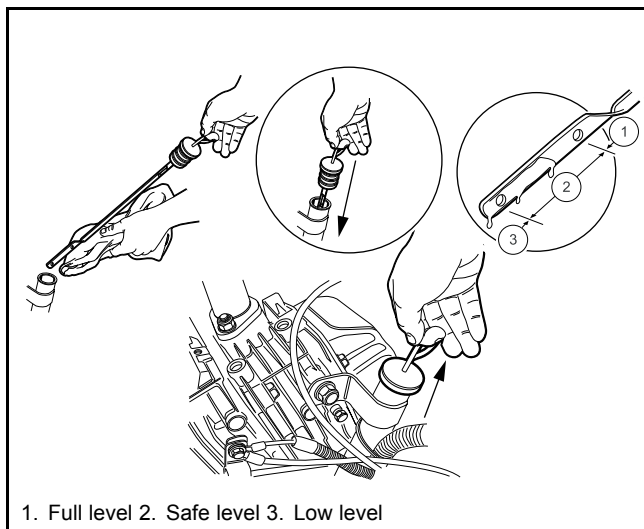

2662

**Figure 32 Engine Oil Level Check**

## ENGINE OIL CHANGE

Engine oil should be changed after the first 100 hours of operation. After that, it should be changed every 200 hours of operation or annually, whichever comes first.

1. Turn the key switch to the OFF position, then remove the key. Place the Forward/Reverse handle in the NEUTRAL position. Chock the front wheels.
2. Access the engine compartment.
3. Disconnect battery and spark plug wire. **See Side-Post Battery: Disconnecting the Battery-Gasoline Vehicles on page 19.**  
**See Top-Post Battery: Disconnecting the Battery-Gasoline Vehicles on page 20.**
4. Position a pan designed for oil changes under the drain plug (1) (**Figure 33**).

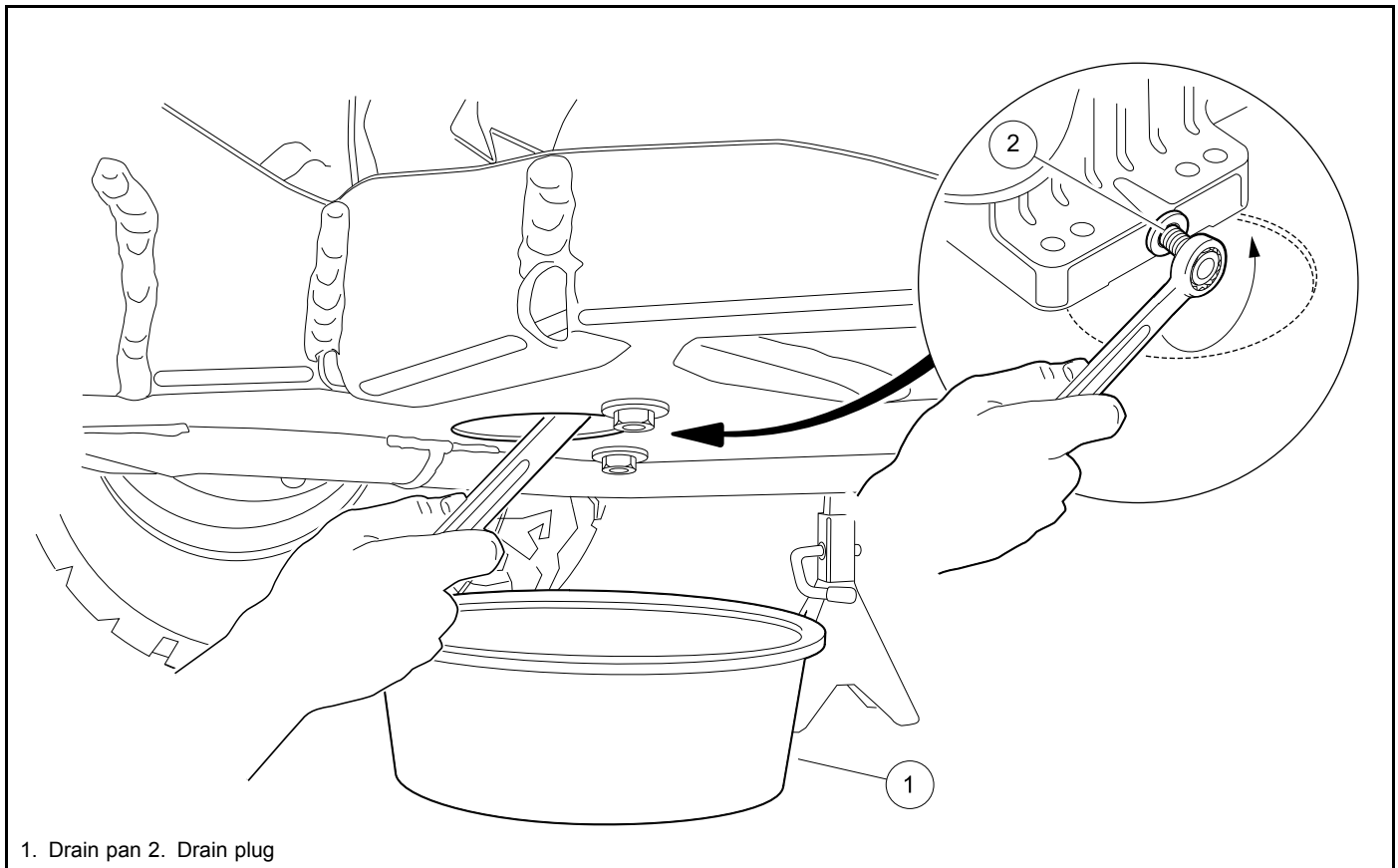

2667  
Figure 33 Engine Oil Drain Plug and Pan

5. Use a 14 mm socket or wrench to remove the drain plug, turning it counterclockwise, and allow the engine oil to drain into the pan. **See following WARNING.**

### **▲ WARNING**

- Do not attempt to change engine oil when the engine is hot or even warm. Engine oil can cause skin burns.
  - Wear safety glasses or approved eye protection when servicing the vehicle. Wear rubber gloves when handling oil drain plug and oil drain pan.
6. Clean the oil drain plug threads with solvent to remove oil and oil residue. Make sure that the compression washer remains on the drain plug.
  7. Use a 14 mm socket or wrench and replace the oil drain plug, turning it clockwise, and tighten to 18 ft·lb (24.4 N·m).
  8. Remove the dipstick and add engine oil into the dipstick port. Use a funnel or pour spout to direct the oil into the dipstick port. The engine requires 40.5 fl-oz (1.2 L) of oil per change. 10W-30 or 5W-30 grade SE or higher is recommended. Refer to oil viscosity guidelines for selection of oil grade (**Figure 34**). Replace the dipstick.

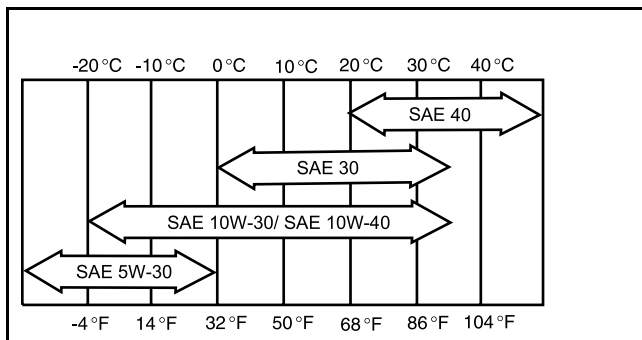

213

Figure 34 Oil Viscosity Chart

9. Connect battery and spark plug wire. **See Side-Post Battery: Connecting the Battery-Gasoline Vehicles on page 20.**  
**See Top-Post Battery: Connecting the Battery-Gasoline Vehicles on page 20.**
10. With the Forward/Reverse handle in the NEUTRAL position and the Maintenance/Service switch in the SERVICE position, start and run the engine for a few minutes. Observe the drain plug from under the vehicle and watch for oil leaks. If leaks appear, begin with step 1 and repeat the appropriate steps as needed to correct the problem.
11. Remove the dip stick and check the engine oil as a final step. Replace the dip stick.

## FUELING INSTRUCTIONS – GASOLINE VEHICLE

See General Warnings on page 16.

### **⚠ DANGER**

- Turn the key switch to the OFF position before fueling.
- Do not pour fuel into the fuel tank when the engine is hot or while it is running.
- Be sure the fuel tank ground wire on the tank is properly connected before fueling the vehicle.
- To avoid electric arc caused by static electricity, the fuel storage/pumping device must be grounded. If the pump is not grounded, the vehicle must be grounded to the pump before and during the fueling operation.
- If the vehicle has an all-weather enclosure installed, be sure the fuel tank is properly vented as shown in Figure 35.
- To avoid the possibility of fire, clean up any spilled fuel before operating the vehicle.

### **CAUTION**

- Use unleaded gasoline only.
- Whenever possible, avoid using oxygenated and blended fuels.
- Do not use any fuel with an alcohol content that exceeds 10% by volume (such as E15 and E85). Ethanol is an alcohol that readily absorbs moisture, causing corrosion of fuel system components. It

CAUTION CONTINUED ON NEXT PAGE,

## CAUTION

also damages neoprene and other plastic and rubber components. Use of these fuels in this vehicle will void the warranty.

- Do not repeatedly attempt to start a vehicle when the fuel pump is dry (no gas in tank). Doing so can damage the fuel pump.

**NOTE:** Whenever possible, avoid using oxygenated fuels and fuels that are blended with alcohol. Vehicles to be stored for extended periods should be prepared for storage as instructed. See **Preparing the Gasoline Vehicle for Extended Storage** on page 42.

1. Remove the fuel cap located on the passenger-side panel and fill the fuel tank with fresh unleaded gasoline only. See preceding **CAUTION** and **NOTE**.
2. Replace fuel cap on tank. Ensure cap is tightened securely (tighten until it clicks).

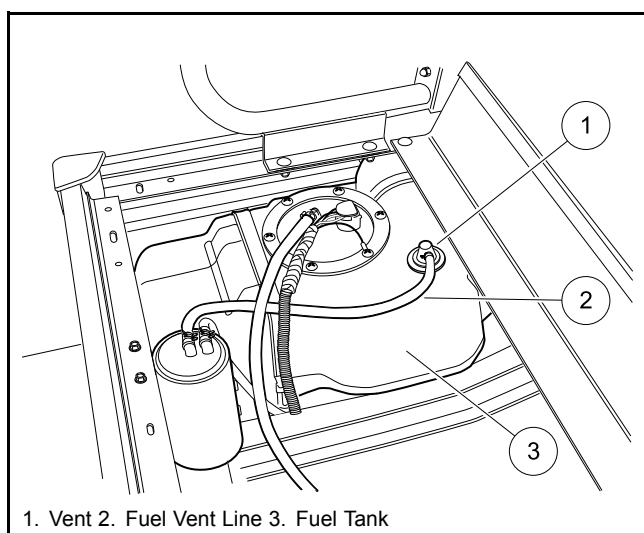

1. Vent 2. Fuel Vent Line 3. Fuel Tank

2832

**Figure 35 Fuel Tank**

## CLEANING THE VEHICLE

Carryall vehicles are equipped with an ArmorFlex® front body and an all-aluminum rear body and cargo bed. Use only commercially available automotive cleaners with a sponge or soft cloth for normal cleaning. A garden hose at normal residential water pressure is adequate. To remove oxidation or discoloration from aluminum, use a commercially available aluminum cleaner paste and fine grade (No. 00) steel wool.

Club Car does not recommend any type of pressure washer or steam cleaning. Such a process will expose electrical components to moisture. Moisture entering electrical components can result in water damage and subsequent component failure.

Use non-abrasive wax products. Battery acid, fertilizers, tars, asphalt, creosote, paint, or chewing gum should be removed immediately to prevent possible stains.

The seats of the vehicle will last longer with proper cleaning. Use a solution of 10% liquid soap and warm water applied with a soft cloth. For imbedded dirt, a soft bristle brush may be used. For heavy soiling, difficult stains or scratches, blemishes, or other body damage, see the appropriate Maintenance and Service Manual or contact your local Club Car dealer.

**NOTE:** Dispose of waste water properly.

## ACCESSORIES

---

A complete line of parts and accessories is available from Club Car channel partners. To find your local authorized Club Car dealer, visit [www.clubcardealer.com](http://www.clubcardealer.com), call 1-800-ClubCar (258-2227), or scan this QR Code (**Figure 36**) to be taken to the Club Car dealer locator. Download a QR Code reader such as RedLaser or Barcode Scanner to your cell phone or tablet.



3118

Figure 36 Dealer Locator QR Code

Care should be taken that these accessories are properly installed by trained technicians, and they are used in the manner for which they were designed. **See following WARNING.**

### **⚠ WARNING**

---

- Custom cab assemblies, weatherproof enclosures, door kits, and tinted windshields will not protect occupants from flying objects.
- If the vehicle has a portable refreshment center option installed in the bed, it must be removed before unlatching and lifting the bed.
- If the vehicle is equipped with an electric powered lift bed, remove the bed before servicing the bed lift system.
- Cargo load includes the weight of optional equipment. See Vehicle Load Capacities on page 36.

### **CAUTION**

---

- Combined use of electric-powered accessories for an extended period of time could discharge the battery even with the engine running. Be aware of charging system capacity rating and keep combined accessory use at or below that rating. See Vehicle Specifications on page 69. Failure to heed this caution could result in the vehicle shutting off, possibly leaving operator and passengers stranded.

## SUBSEQUENT OWNER REGISTRATION

---

In the event a vehicle is bought as a used vehicle, we strongly urge the new owner to register the vehicle with Club Car. This will enable us to contact you if the need arises. Please send your name, address, and serial number(s) of the vehicle(s) to Club Car, LLC, P.O. Box 204658, Augusta, Georgia 30917-4658, Attention: Vehicle Registration.

## VEHICLE SPECIFICATIONS

### VEHICLE SPECIFICATIONS – ELECTRIC VEHICLES

| SPECIFICATIONS  | CARRYALL 500                             | CARRYALL 550                             | CARRYALL 700                             |
|---|--|--|--|
| <b>POWER SOURCE</b>   | <b>ELECTRIC</b>                          | <b>ELECTRIC</b>                          | <b>ELECTRIC</b>                          |
| <b>Drive motor:</b> Direct drive, 48 volts DC, shunt wound, 3.7 hp  | •  | •  | •  |
| <b>Transaxle:</b> Double reduction helical gear with 12.3:1 direct drive axle   | •  | •  | •  |
| <b>Electrical system:</b> 48 volts DC, reduced speed reverse  | •  | •  | •  |
| <b>Batteries:</b> High capacity, deep cycle, 6-volt   | •  | •  | •  |
| <b>Charger:</b> Automatic, 48-volt; UL and CSA listed<br><b>See QuiQ Battery Charger Specifications on page 70.</b>   | •  | •  | •  |
| <b>STEERING/SUSPENSION/BRAKES</b>   |  |  |  |
| <b>Steering:</b> Self-adjusting rack and pinion   | •  | •  | •  |
| <b>Suspension:</b> Independent leaf spring with dual hydraulic shocks   | •  | •  | •  |
| <b>Brakes:</b> Mechanical brake cable system to manually-adjusted drum brakes on all four wheels. Park brake is automatically released. Multi-latch ratchet and pawl. | •  | •  | •  |
| <b>BODY/CHASSIS</b>   |  |  |  |
| <b>Frame/chassis:</b> Twin I-Beam welded aluminum   | •  | •  | •  |
| <b>Side and rear body:</b> Aluminum   | •  | •  | •  |
| <b>Front body:</b> ArmorFlex®   | •  | •  | •  |
| <b>Front body finish:</b> Automotive-grade paint with clear-coat finish   | •  | •  | •  |
| <b>Tires:</b> 20 x 10 - 10 tubeless, 6-ply rated load range front and rear  | •  |  | •  |
| <b>Tires (Turf):</b> 23 x 10.5 - 12 tubeless, 4-ply rated load range front and rear   |  | •  |  |
| <b>Tires (All-Terrain):</b> 22 x 11 - 10 tubeless, 6-ply rated load range front and rear  |  | •  |  |
| <b>DIMENSIONS/WEIGHT</b>  |  |  |  |
| <b>Overall length:</b> Standard boxbed configuration<br>Add for Heavy-Duty Bumper:  | 118 in (299.7 cm)<br>1.8 in (4.5 cm)     | 118 in (299.7 cm)<br>1.8 in (4.5 cm)     | 139.3 in (358.8 cm)<br>1.8 in (4.5 cm)   |
| <b>Overall width</b><br>with mirrors:   | 50.3 in (127.7 cm)<br>62.6 in (159.0 cm) | 50.3 in (127.7 cm)<br>62.6 in (159.0 cm) | 50.3 in (127.7 cm)<br>62.6 in (159.0 cm) |
| <b>Overall height:</b> At steering wheel  | 47.1 in (119.6 cm)                       | 51.2 in (130 cm)                         | 47.1 in (119.6 cm)                       |
| <b>Overall height:</b> with canopy  | 70.7 in (179.5 cm)                       | 74 in (187.9 cm)                         | 70.7 in (179.5 cm)                       |
| <b>Overall height:</b> with cab   | 74.3 in (188.7 cm)                       | 77.6 in (197.1 cm)                       | 74.3 in (188.7 cm)                       |
| <b>Wheelbase</b>  | 78.1 in (198.3 cm)                       | 78.1 in (198.3 cm)                       | 99.1 in (251.7 cm)                       |
| <b>Ground clearance</b>   | 5.6 in (14.2 cm)                         | 6 in (15.2 cm)                           | 5.6 in (14.2 cm)                         |
| <b>Front wheel tread</b>  | 36.6 in (92.9 cm)                        | 36.6 in (92.9 cm)                        | 36.6 in (92.9 cm)                        |
| <b>Rear wheel tread</b>   | 39.5 in (100.3 cm)                       | 39.5 in (100.3 cm)                       | 39.5 in (100.3 cm)                       |

| SPECIFICATIONS  | CARRYALL 500  | CARRYALL 550  | CARRYALL 700  |
|---|---|---|---|
| <b>POWER SOURCE</b>   | <b>ELECTRIC</b>   | <b>ELECTRIC</b>   | <b>ELECTRIC</b>   |
| <b>Weight:</b> Standard electric vehicle (curb weight)                | 1393 lb (632 kg)  | 1402 lb (636 kg)  | 1475 lb (669 kg)  |
| <b>Maximum forward speed</b>  | 15 to 17 mph<br>(24 to 27 km/h)   | 15 to 17 mph<br>(24 to 27 km/h)   | 15 to 17 mph<br>(24 to 27 km/h)   |
| <b>Outside clearance circle</b> (diameter)                            | 248.5 in (631.2 cm)   | 268 in (680.7 cm)   | 340.5 in (864.9 cm)   |
| <b>Turning radius per SAE J 695</b>                                   | 119 in (302.2 cm)   | 126.5 in (321.3 cm)   | 162.8 in (413.4 cm)   |
| <b>Intersecting aisle clearance</b>                                   | 88.9 in (225.8 cm)  | 84.2 in (213.9 cm)  | 123.9 in (314.7 cm)   |
| <b>Floorboard height</b>  | 12.5 in (31.7 cm)   | 15 in (38.1 cm)   | 12.5 in (31.7 cm)   |
| <b>Load bed height</b>  | 29.5 in (74.9 cm)   | 31.6 in (80.2 cm)   | 29.5 in (74.9 cm)   |
| <b>Load bed size:</b> Box bed inside dimensions                       | 44.2 x 47.5 x 10.5 in<br>(112.2 x 120.6 x<br>26.6 cm)   | 44.2 x 47.5 x 10.5 in<br>(112.2 x 120.6 x<br>26.6 cm)   | 64.5 x 47.5 x 10.5 in<br>(163.8 x 120.6 x<br>26.6 cm)   |
| <b>Load bed size:</b> Flat bed inside dimensions                      | 46.2 x 48.8 in<br>(117.3 x 123.9 cm)  | 46.2 x 48.8 in<br>(117.3 x 123.9 cm)  | 65.5 x 48.8 in<br>(166.4 x 123.9 cm)  |
| <b>Vehicle rated capacity:</b> Level surface only                     | 1200 lb (544.3 kg)  | 900 lb (408.2 kg)   | 1500 lb (680.3 kg)  |
| <b>Standard seating capacity</b>                                      | 2   | 2   | 2   |
| <b>LIQUID CAPACITIES</b>  |   |   |   |
| <b>Transaxle</b>  | 22 fl-oz (0.67 L)   | 22 fl-oz (0.67 L)   | 22 fl-oz (0.67 L)   |
| <b>TIRE PRESSURE</b>  |   |   |   |
| <b>Front and rear</b>   | 28 to 32 psig<br>(193 to 221 kPa)   | 20 to 22 psig<br>(138 to 152 kPa)   | 28 to 32 psig<br>(193 to 221 kPa)   |
| <b>NOISE AND VIBRATION</b>  |   |   |   |
| <b>Drive-by noise level to operator</b><br>Test method: EN 12053:2001 | 70.3 dBa<br>Uncertainty: ± 2 dBa  | 76 dBa<br>Uncertainty: ± 2 dBa  | 73 dBa<br>Uncertainty: ± 2 dBa  |
| <b>Vibration at driver's seat</b><br>Test method: EN 13059:2002       | 0.6 (m/s <sup>2</sup> ) <sup>2</sup><br>Uncertainty:<br>± 0.18 (m/s <sup>2</sup> ) <sup>2</sup> | 1.2 (m/s <sup>2</sup> ) <sup>2</sup><br>Uncertainty:<br>± 0.36 (m/s <sup>2</sup> ) <sup>2</sup> | 0.7 (m/s <sup>2</sup> ) <sup>2</sup><br>Uncertainty:<br>± 0.21 (m/s <sup>2</sup> ) <sup>2</sup> |

## QUIQ BATTERY CHARGER SPECIFICATIONS

| QUIQ BATTERY CHARGER SPECIFICATIONS |                                   |
|-------------------------------------|-----------------------------------|
| <b>AC INPUT</b>                     |                                   |
| <b>AC Voltage – range</b>           | 85 to 265 VAC (acceptable)        |
| <b>AC Voltage – nominal</b>         | 120 to 230 VAC                    |
| <b>Frequency</b>                    | 45 to 65 Hz                       |
| <b>AC Power Factor – nominal</b>    | >0.99 @ 120 VAC / >0.98 @ 230 VAC |
| <b>POWER CONSUMPTION</b>            |                                   |

| <b>QUIQ BATTERY CHARGER SPECIFICATIONS</b> |   |
|--|---|
| <b>AC current (amps)</b>                   | Max: 12 Amps<br>Nominal: 9.5 Amps rms @ 120 VAC<br>5 Amps rms @ 230 VAC |
| <b>DC OUTPUT</b>                           |   |
| <b>DC voltage (VDC) – nominal</b>          | 48 V  |
| <b>DC voltage (VDC) – maximum</b>          | 68 V  |
| <b>DC current – maximum</b>                | 18 Amps   |
| <b>Interlock current – maximum</b>         | 1 Amp   |
| <b>DIMENSIONS/WEIGHT</b>                   |   |
| Case – Overall length                      | 11 in (28 cm)   |
| Case – Overall width                       | 9.7 in (24.6 cm)  |
| Case – Overall height                      | 4.3 in (11 cm)  |
| Weight – with standard output cord         | < 11 lb (< 5 kg)  |
| <b>MOUNTING CONFIGURATION</b>              |   |
| Mounting                                   | Onboard   |

## VEHICLE SPECIFICATIONS – GASOLINE VEHICLES

**NOTE:** Engine horsepower and torque specifications are provided by the engine manufacturer. Actual horsepower and torque in use may differ and are dependent on environmental conditions as well as maintenance condition of the engine.

| SPECIFICATIONS  | CARRYALL 500                         | CARRYALL 550                         | CARRYALL 700                           |
|---|--------------------------------------|--------------------------------------|--|
| <b>POWER SOURCE</b>   | <b>GASOLINE</b>                      | <b>GASOLINE</b>                      | <b>GASOLINE</b>                        |
| <b>Engine:</b> 4 cycle, OHC, 404 cc, 14.0 Horsepower (10.4 kW) rated engine @ 3600 RPM (per SAE J 1940), single cylinder, air cooled, with splash lubrication system  | •                                    | •                                    | •                                      |
| <b>Fuel system:</b> Electronic fuel injection (EFI), high-pressure rotary fuel pump with 10 micron fuel filter  | •                                    | •                                    | •                                      |
| <b>Battery:</b> 12-volt, side-post or top-post  | •                                    | •                                    | •                                      |
| <b>Governor:</b> Automatic ground speed sensing, internally geared in transaxle   | •                                    | •                                    | •                                      |
| <b>Ignition:</b> Digital CDI with electronic RPM limiter  | •                                    | •                                    | •                                      |
| <b>Transaxle:</b> Precision helical gears, forward/reverse with neutral position (11.47:1 forward; 15.63:1 reverse), with optional limited slip differential          | •                                    | •                                    | •                                      |
| <b>Electrical system:</b> 12 volt, 500 cca at 0 °F (-17.8 °C), 650 cca at 32 °F (0 °C). 105-minute reserve capacity   | •                                    | •                                    | •                                      |
| <b>Gasoline Vehicle Electrical Charging System:</b> 23 amps at max. RPM.  | •                                    | •                                    | •                                      |
| <b>Torque converter:</b> Automatic, variable speed, dry type  | •                                    | •                                    | •                                      |
| <b>STEERING/SUSPENSION/BRAKES</b>   |                                      |                                      |  |
| <b>Steering:</b> Self-adjusting rack and pinion   | •                                    | •                                    | •                                      |
| <b>Suspension:</b> Independent leaf spring with dual hydraulic shocks   | •                                    | •                                    | •                                      |
| <b>Brakes:</b> Mechanical brake cable system to manually-adjusted drum brakes on all four wheels. Park brake is automatically released. Multi-latch ratchet and pawl. | •                                    | •                                    | •                                      |
| <b>BODY/CHASSIS</b>   |                                      |                                      |  |
| <b>Frame/chassis:</b> Twin I-Beam welded aluminum   | •                                    | •                                    | •                                      |
| <b>Side and rear body:</b> Aluminum   | •                                    | •                                    | •                                      |
| <b>Front body:</b> ArmorFlex®   | •                                    | •                                    | •                                      |
| <b>Front body finish:</b> Automotive-grade paint with clear-coat finish   | •                                    | •                                    | •                                      |
| <b>Tires:</b> 20 x 10 - 10 tubeless, 6-ply rated load range front and rear  | •                                    |                                      | •                                      |
| <b>Tires (Turf):</b> 23 x 10.5 - 12 tubeless, 4-ply rated load range front and rear   |                                      | •                                    |  |
| <b>Tires (All-Terrain):</b> 22 x 11 - 10 tubeless, 6-ply rated load range front and rear  |                                      | •                                    |  |
| <b>DIMENSIONS/WEIGHT</b>  |                                      |                                      |  |
| <b>Overall length:</b> Standard boxbed configuration<br>Add for Heavy-Duty Bumper:  | 118 in (299.7 cm)<br>1.8 in (4.5 cm) | 118 in (299.7 cm)<br>1.8 in (4.5 cm) | 139.3 in (358.8 cm)<br>1.8 in (4.5 cm) |

| SPECIFICATIONS  | CARRYALL 500  | CARRYALL 550  | CARRYALL 700  |
|---|---|---|---|
| <b>POWER SOURCE</b>   | <b>GASOLINE</b>   | <b>GASOLINE</b>   | <b>GASOLINE</b>   |
| <b>Overall width</b><br>with mirrors:                                 | 50.3 in (127.7 cm)<br>62.6 in (159.0 cm)  | 50.3 in (127.7 cm)<br>62.6 in (159.0 cm)  | 50.3 in (127.7 cm)<br>62.6 in (159.0 cm)  |
| <b>Overall height:</b> at steering wheel                              | 47.1 in (119.6 cm)  | 51.2 in (130 cm)  | 47.1 in (119.6 cm)  |
| <b>Overall height:</b> with canopy                                    | 70.7 in (179.5 cm)  | 74 in (187.9 cm)  | 70.7 in (179.5 cm)  |
| <b>Overall height:</b> with cab                                       | 74.3 in (188.7 cm)  | N/A   | 74.3 in (188.7 cm)  |
| <b>Wheelbase</b>  | 78.1 in (198.3 cm)  | 78.1 in (198.3 cm)  | 99.1 in (251.7 cm)  |
| <b>Ground clearance</b>   | 5.2 in (13.2 cm)  | 6 in (15.2 cm)  | 5.2 in (13.2 cm)  |
| <b>Front wheel tread</b>  | 36.6 in (92.9 cm)   | 36.6 in (92.9 cm)   | 36.6 in (92.9 cm)   |
| <b>Rear wheel tread</b>   | 39.5 in (100.3 cm)  | 39.5 in (100.3 cm)  | 39.5 in (100.3 cm)  |
| <b>Weight:</b> Standard gasoline vehicle (curb weight)                | 907 lb (411 kg)   | 942 lb (427 kg)   | 993 lb (450 kg)   |
| <b>Maximum forward speed</b>  | 15 to 17 mph<br>(24 to 27 km/h)   | 15 to 17 mph<br>(24 to 27 km/h)   | 15 to 17 mph<br>(24 to 27 km/h)   |
| <b>Outside clearance circle</b> (diameter)                            | 248.5 in (631.2 cm)   | 268 in (680.7 cm)   | 340.5 in (864.9 cm)   |
| <b>Turning radius per SAE J 695</b>                                   | 119 in (302.2 cm)   | 126.5 in (321.3 cm)   | 162.8 in (413.4 cm)   |
| <b>Intersecting aisle clearance</b>                                   | 88.9 in (225.8 cm)  | 84.2 in (213.9 cm)  | 123.9 in (314.7 cm)   |
| <b>Floorboard height</b>  | 12.5 in (31.7 cm)   | 15 in (38.1 cm)   | 12.5 in (31.7 cm)   |
| <b>Load bed height</b>  | 29.5 in (74.9 cm)   | 31.6 in (80.2 cm)   | 29.5 in (74.9 cm)   |
| <b>Load bed size:</b> Box bed inside dimensions                       | 44.2 x 47.5 x 10.5 in<br>(112.2 x 120.6 x<br>26.6 cm)   | 44.2 x 47.5 x 10.5 in<br>(112.2 x 120.6 x<br>26.6 cm)   | 64.5 x 47.5 x 10.5 in<br>(163.8 x 120.6 x<br>26.6 cm)   |
| <b>Load bed size:</b> Flat bed inside dimensions                      | 46.2 x 48.8 in<br>(117.3 x 123.9 cm)  | 46.2 x 48.8 in<br>(117.3 x 123.9 cm)  | 65.5 x 48.8 in<br>(166.4 x 123.9 cm)  |
| <b>Vehicle rated capacity:</b> Level surface only                     | 1200 lb (544.3 kg)  | 900 lb (408.2 kg)   | 1500 lb (680.3 kg)  |
| <b>Standard seating capacity:</b> (persons)                           | 2   | 2   | 2   |
| <b>LIQUID CAPACITIES</b>  |   |   |   |
| <b>Engine crankcase</b>   | 40.5 fl-oz (1.2 L)  | 40.5 fl-oz (1.2 L)  | 40.5 fl-oz (1.2 L)  |
| <b>Transaxle</b>  | 67.6 fl-oz (2 L)  | 67.6 fl-oz (2 L)  | 67.6 fl-oz (2 L)  |
| <b>Fuel tank</b>  | 4.6 gallons (17.4 L)  | 4.6 gallons (17.4 L)  | 4.6 gallons (17.4 L)  |
| <b>TIRE PRESSURE</b>  |   |   |   |
| <b>Front and rear</b>   | 28 to 32 psig<br>(193 to 221 kPa)   | 20 to 22 psig<br>(138 to 152 kPa)   | 28 to 32 psig<br>(193 to 221 kPa)   |
| <b>NOISE AND VIBRATION</b>  |   |   |   |
| <b>Drive-by noise level to operator</b><br>Test method: EN 12053:2001 | 77.2 dBa<br>Uncertainty: ± 2 dBa  | 83.4 dBa<br>Uncertainty: ± 2 dBa  | 77.2 dBa<br>Uncertainty: ± 2 dBa  |
| <b>Vibration at driver's seat</b><br>Test method: EN 13059:2002       | 0.7 (m/s <sup>2</sup> ) <sup>2</sup><br>Uncertainty: ± 0.21<br>(m/s <sup>2</sup> ) <sup>2</sup> | 1.6 (m/s <sup>2</sup> ) <sup>2</sup><br>Uncertainty: ± 0.49<br>(m/s <sup>2</sup> ) <sup>2</sup> | 0.8 (m/s <sup>2</sup> ) <sup>2</sup><br>Uncertainty: ± 0.22<br>(m/s <sup>2</sup> ) <sup>2</sup> |

## WARRANTIES

### CLUB CAR® LIMITED WARRANTY FOR TRANSPORTATION AND UTILITY VEHICLES WARRANTY

CLUB CAR, LLC (“CLUB CAR”) hereby warrants to the Original Purchaser or Lessee, as those terms are defined herein, and subject to the provisions, limitations and exclusions in this limited warranty, that its new vehicle or new component purchased from CLUB CAR or an Authorized Dealer or Distributor shall be free from defects in material and workmanship under normal use and service for the periods stated below, subject to the provisions, limitations and exclusions in this limited warranty.

This limited warranty covers material, workmanship and repair labor cost as to those items specifically listed below for the periods specified. Such repair labor shall be performed only by CLUB CAR, its Authorized Dealers or Distributors, or a service agency approved by CLUB CAR. For repairs made by qualified technicians other than CLUB CAR’s factory technicians or an Authorized Dealer or Distributor, CLUB CAR will provide only the replacement parts or components.

IF THE WARRANTY REGISTRATION FORM IS NOT COMPLETED AND RETURNED TO CLUB CAR AT THE TIME OF THE ORIGINAL RETAIL SALE, PURCHASER MUST PROVIDE PROOF OF DATE OF PURCHASE WITH ANY WARRANTY CLAIM.

| TO THE ORIGINAL OWNER ONLY (NON-TRANSFERABLE)  | TERMS COVERED | HOURS/ AMP HOURS COVERED |
|--|---------------|--------------------------|
| <b>LIMITED THREE YEAR:</b> Engine assembly, transaxle assembly (gasoline vehicle), starter/generator (gasoline vehicle), motor, transaxle assembly (electric vehicle), and main frame assembly.  | 3 YEARS       | 3000                     |
| <b>LIMITED TWO YEAR:</b> Solenoid, MCOR, limit switches, voltage regulators, FNR switches, brake components, wiring harness, electrical switches, canopy systems, seats, pedal group assembly, body, cab assembly and doors, and driving range protective enclosure, portable refreshment center and all original equipment options and accessories supplied by CLUB CAR, and all remaining components of the vehicle not specified otherwise. | 2 YEARS       | 2000                     |
| <b>6-VOLT BATTERY (STANDARD DUTY)</b>  | 4 YEARS       | 18000                    |
| <b>6-VOLT BATTERY (HEAVY DUTY)</b>   | 4 YEARS       | 20000                    |
| <b>8-VOLT BATTERY (STANDARD/HEAVY DUTY)</b>  | 4 YEARS       | 16000                    |
| <b>ONBOARD COMPUTER (IF SO EQUIPPED)</b>   | 4 YEARS       | 16000                    |
| <b>CONTROLLER</b>  | 4 YEARS       | 16000                    |
| <b>BATTERY CHARGER</b>   | 4 YEARS       |                          |

### EXCLUSIONS

Excluded from any CLUB CAR warranty is damage to a vehicle or component resulting from a cause other than a defect including poor maintenance, neglect, abuse, accident and collision, maintenance adjustments, unreasonable or unintended strain or use, improper installation of accessories, installation of parts or accessories that are not original equipment including Club Car approved or non-approved GPS systems, non-approved alteration and acts of God. Also excluded from any CLUB CAR warranty are all fuses, filters, decals (except safety decals), lubricants, routine wear items such as the charger plug and receptacle, engine mounts, bed floor lining, mats, pads, spark plugs, light bulbs, brake shoes, belts, brushes, bushings, drive buttons, cosmetic deterioration, and items that deteriorate, fade or fail due to exposure or ordinary wear and tear.

The provisions of this limited warranty shall not apply to failure due to the following conditions:

1. Abuse such as overcharging, undercharging, improper fluid levels, loose wiring and fasteners, or rusted or corroded hardware.

2. Use of water in batteries, including tap water, that contains impurities. Distilled water or a properly maintained, Club Car approved battery water deionizer and filter system should be used to ensure water quality.
3. Lack of proper maintenance such as preventive maintenance checks, proper rotation of vehicles in a fleet application, maintaining proper tire pressure and alignment and tightening loose wire connections as outlined in the owner's manual.
4. Damages caused by improper installation of the component.
5. Neglect, breakage, freezing, fire, explosion, wreckage, melted terminal posts, the addition of any chemical, or the operation of the battery in an uncharged condition (below half charge 1.200 specific gravity); the installation of the batteries in reverse or recharging in reverse, breakage of containers, covers, or terminal post, or batteries used in applications for which they were not designed.
6. A battery damaged by a defective charger or batteries in vehicles that do not receive proper charging.
7. A vehicle not having an operational charger on a circuit that has the parameters specified in the vehicle owner's manual. (Number of operational chargers must equal the number of operational vehicles.)
8. Improper charging of a vehicle due to the use of a battery charger model not approved by Club Car for use with the vehicle.
9. Failed semiconductor parts such diodes and fuses that are vulnerable to electrical overloads (including lightning) beyond the control of CLUB CAR.
10. Damaged charger DC cord set with plug, which is a wear item and subject to user abuse.
11. Use of gasoline containing more than 10% ethanol.

Without limiting the generality of the foregoing in any way, and as part of its limited warranty exclusion, CLUB CAR does not warrant that its vehicle or components such as batteries, computer, controller or electrical device are suitable for use in any application other than in its products. As in the use of any vehicle, batteries, computer, controller or electrical device, a prudent owner will read and study the owner's manual, the operator instructions and the warning labels; and will exercise due care in working on or around vehicles, batteries or electrical devices.

Transportation expenses for warranty services are also excluded from this warranty.

## **VOIDING OF WARRANTY**

THIS AND ANY OTHER WARRANTY SHALL BE VOID IF THE VEHICLE OR COMPONENT IS ABUSED OR USED IN AN UNINTENDED MANNER OR SHOWS INDICATIONS THAT IT HAS BEEN ALTERED IN ANY WAY, INCLUDING, BUT NOT LIMITED TO, MODIFICATION OF THE SPEED GOVERNOR, BRAKING SYSTEM, STEERING, TRANSAXLE, OR OTHER OPERATING SYSTEMS OF THE CAR TO CAUSE IT TO PERFORM OUTSIDE CLUB CAR SPECIFICATIONS. THE WARRANTY IS LIKEWISE VOID IF THE VEHICLE SHOWS INDICATIONS THAT REASONABLE OR NECESSARY MAINTENANCE AS OUTLINED IN THE OWNER'S MANUAL AND MAINTENANCE AND SERVICE MANUAL WAS NOT PERFORMED AT THE TIME AND IN THE MANNER SPECIFIED IN SUCH MANUALS.

## **SOLE REMEDY**

CLUB CAR's liability under this limited warranty or in any action whether based upon warranty, contract, negligence, strict product liability or otherwise, shall be the repair or replacement, at CLUB CAR's option, of the vehicle or component thereof that CLUB CAR deems to be defective. Replacement shall mean furnishing, during the applicable limited warranty period, a new vehicle or factory-reconditioned vehicle or component thereof that is identical or reasonably equivalent to the warranted product or component at no cost to the purchaser. Repair shall mean remedying a defect in the vehicle or component thereof at no cost to the purchaser during the applicable limited warranty period. CLUB CAR reserves the right to test and recharge any component returned for adjustment. If CLUB CAR elects to repair the vehicle or component, it may provide factory-reconditioned parts or components. All parts and components replaced under warranty shall become the property of CLUB CAR.

## **DISCLAIMER**

THIS LIMITED WARRANTY IS EXCLUSIVE. CLUB CAR MAKES NO OTHER WARRANTY OF ANY KIND, EXPRESSED OR IMPLIED. ANY IMPLIED WARRANTIES OF MERCHANTABILITY OR FITNESS FOR A

PARTICULAR PURPOSE ARE HEREBY DISCLAIMED BY CLUB CAR AND EXCLUDED FROM THIS WARRANTY. THE PURCHASER AND CLUB CAR EXPRESSLY AGREE THAT THE SOLE REMEDY OF THE REPLACEMENT OR REPAIR OF THE DEFECTIVE VEHICLE OR COMPONENT THEREOF IS THE SOLE REMEDY OF THE PURCHASER. CLUB CAR MAKES NO OTHER REPRESENTATION OR WARRANTY OF ANY KIND, AND NO REPRESENTATIVE, EMPLOYEE, DISTRIBUTOR OR DEALER OF CLUB CAR HAS THE AUTHORITY TO MAKE OR IMPLY ANY REPRESENTATION, PROMISE OR AGREEMENT, WHICH IN ANY WAY VARIES THE TERMS OF THIS WARRANTY.

In the event that another pre-printed warranty document, certificate or both offered by or through Club Car at the time of sale of this vehicle (each an "Additional Warranty Document") is deemed to conflict with the limitations or exclusions contained herein, the limitations and exclusions contained herein shall continue to apply to both this limited warranty statement and, to the maximum extent permitted by law, to each Additional Warranty Document.

### **NO CONSEQUENTIAL DAMAGES**

IN NO EVENT SHALL CLUB CAR BE LIABLE FOR ANY INCIDENTAL OR CONSEQUENTIAL DAMAGES INCLUDING, BUT NOT LIMITED TO, LOSS RELATED TO PROPERTY OTHER THAN THE VEHICLE, LOSS OF USE, LOSS OF TIME, INCONVENIENCE, OR ANY OTHER ECONOMIC LOSS.

Some states allow neither limitation on the duration of an implied warranty nor exclusions or limitation of incidental or consequential damages. Therefore, the above limitations or exclusions may not apply to you. This warranty gives you specific legal rights, and you may also have other rights, which vary from state to state.

### **HOW TO MAKE A WARRANTY CLAIM**

To make a warranty claim under this limited warranty, you must present the vehicle or defective component with evidence of proof of purchase date and number of amp-hours (if applicable) to an authorized CLUB CAR dealer.

For warranty-related communication, contact Warranty Services, Club Car, 4125 Washington Rd., Evans, GA 30809, USA, 706-863-3000.

### **WARNING**

Any modification or change to the vehicle that affects the electrical system, stability or handling of the vehicle, or increases maximum vehicle speed beyond factory specifications, can result in serious personal injury or death.

### **FEDERAL EMISSIONS COMPONENT DEFECT WARRANTY**

EMISSIONS COMPONENT DEFECT WARRANTY COVERAGE - This emission warranty is applicable in all States, except the State of California.

Club Car, LLC ("CLUB CAR") warrant(s) to the initial retail purchaser and each subsequent owner, that this Non-road engine ("engine") has been designed, built, and equipped to conform at the time of initial sale to all applicable regulations of the U.S. Environmental Protection Agency (EPA), and that the engine is free of defects in materials and workmanship which would cause this engine to fail to conform with EPA regulations during its warranty period.

For the components listed under PARTS COVERED, the service dealer authorized by CLUB CAR will, at no cost to you, make the necessary diagnosis, repair, or replacement necessary to ensure that the engine complies with applicable U.S. EPA regulations.

### **EMISSION COMPONENT DEFECT WARRANTY PERIOD**

The warranty period for this engine begins on the date of sale to the initial purchaser and continues for a period of three years.

---

## PARTS COVERED

Listed below are the parts covered by the Emission Components Defect Warranty. Some of the parts listed below may require scheduled maintenance and are warranted up to the first scheduled replacement point for that part.

## EXHAUST EMISSIONS

1. Fuel Metering System
  - 1.1. Carburetor and internal parts (and/or pressure regulator or fuel injection system)
  - 1.2. Air/fuel ratio feedback and control system, if applicable
  - 1.3. Cold start enrichment system, if applicable
2. Air Induction System
  - 2.1. Intake manifold, if applicable
  - 2.2. Air filter
3. Ignition System
  - 3.1. Spark plugs
  - 3.2. Magneto or electronic ignition system
  - 3.3. Spark advance/retard system, if applicable
4. Catalyst or Thermal Reactor System
  - 4.1. Exhaust Manifold, if applicable
5. Miscellaneous Items Used in Above Systems
  - 5.1. Electronic controls, if applicable
  - 5.2. Hoses, belts, connectors, and assemblies

## EVAPORATIVE EMISSIONS

1. Fuel Line
2. Fuel Line Fittings
3. Clamps
4. Fuel Tank
5. Fuel Cap
6. Vapor Hoses
7. Carbon Canister
8. Carbon Canister Mounting Brackets
9. Air Cleaner Purge Port Connector

## REPLACEMENT PARTS DISTRIBUTION CENTER

Replacement parts are provided to the market upon request by the customers. Replacement parts distribution center is located at the Service Parts Department, Club Car, 4125 Washington Road, Evans, Georgia 30809, U.S.A., 706-863-3000. If you have a question regarding your replacement part, you should contact CLUB CAR at 706-863-3000.

## OBTAINING WARRANTY SERVICE

To obtain warranty service, take your engine to the nearest authorized CLUB CAR service dealer. Bring your sales receipts indicating date of purchase for this engine. The service dealer authorized by CLUB CAR will perform the

necessary repairs or adjustments within a reasonable amount of time and furnish you with a copy of the repair order. All parts and accessories replaced under this warranty become the property of CLUB CAR.

For owners located more than 100 miles from an authorized service center, the following will be provided to those applicable owners (excluding the states with high-altitude areas).

- CLUB CAR will either pay for the shipping costs of replacement parts to and from an authorized service center.
- Or CLUB CAR will provide for a service technician to come to the owner to make the warranty repair.
- Or CLUB CAR will pay for the repair to be made at a local non-authorized service center.

### WHAT IS NOT COVERED

- Conditions resulting from tampering, misuse, improper adjustment (unless they were made by the service dealer authorized by CLUB CAR during a warranty repair), alteration, accident, failure to use the recommended fuel and oil, or not performing required maintenance services.
- The replacement parts used for required maintenance services.
- Consequential damages such as loss of time, inconvenience, loss of use of the engine or equipment, etc.
- Diagnosis and inspection charges that do not result in warranty-eligible service being performed.
- Any non-authorized replacement part, or malfunction of authorized parts due to use of non-authorized parts.

### OWNER'S WARRANTY RESPONSIBILITIES

As the engine owner, you are responsible for the performance of the required maintenance listed in your owner's manual. CLUB CAR recommends that you retain all receipts covering maintenance on your engine, but CLUB CAR cannot deny warranty solely for the lack of receipts or for your failure to ensure the performance of all scheduled maintenance.

As the engine owner, you should however be aware that CLUB CAR may deny warranty coverage if your engine or a part has failed due to abuse, neglect, improper maintenance or unapproved modifications.

You are responsible for presenting your engine to the nearest service dealer authorized by CLUB CAR when a problem exists.

If you have any questions regarding your warranty rights and responsibilities, you should contact the CLUB CAR customer service department at 706-863-3000 for the information.

### THINGS YOU SHOULD KNOW ABOUT THE EMISSION CONTROL SYSTEM WARRANTY MAINTENANCE AND REPAIRS

You are responsible for the proper maintenance of the engine. You should keep all receipts and maintenance records covering the performance of regular maintenance in the event questions arise. These receipts and maintenance records should be transferred to each subsequent owner of the engine. CLUB CAR reserves the right to deny warranty coverage if the engine has not been properly maintained. Warranty claims will not be denied, however, solely because of the lack of required maintenance or failure to keep maintenance records.

**MAINTENANCE, REPLACEMENT OR REPAIR OF EMISSION CONTROL DEVICES AND SYSTEMS MAY BE PERFORMED BY ANY REPAIR ESTABLISHMENT OR INDIVIDUAL; HOWEVER, WARRANTY REPAIRS**

---

MUST BE PERFORMED BY A SERVICE DEALER AUTHORIZED BY CLUB CAR. THE USE OF PARTS THAT ARE NOT EQUIVALENT IN PERFORMANCE AND DURABILITY TO AUTHORIZED PARTS MAY IMPAIR THE EFFECTIVENESS OF THE EMISSION CONTROL SYSTEM AND MAY HAVE A BEARING ON THE OUTCOME OF A WARRANTY CLAIM.

If other than the parts authorized by CLUB CAR are used for maintenance replacements or for the repair of components affecting emission control, you should assure yourself that such parts are warranted by their manufacturer to be equivalent to the parts authorized by CLUB CAR in their performance and durability.

#### HOW TO MAKE A CLAIM

All repairs qualifying under this limited warranty must be performed by a service dealer authorized by CLUB CAR. In the event that any emission-related part is found to be defective during the warranty period, you shall notify CLUB CAR customer service department at 706-863-3000 and you will be advised of the appropriate warranty service dealer or service providers where the warranty repair can be performed.

### **CALIFORNIA EMISSION CONTROL WARRANTY STATEMENT**

#### **YOUR WARRANTY RIGHTS AND OBLIGATIONS:**

The California Air Resources Board ("CARB") and Club Car, LLC ("CLUB CAR") are pleased to explain the emission control system warranty on your 2014 or newer vehicle engine (the "emission warranty"). In California, new small off-road engines ("SORE") must be designed, built and equipped to meet the State's stringent anti-smog standards. CLUB CAR shall warrant the emission control system on the vehicle engine for the periods of time listed below provided there has been no abuse, neglect or improper maintenance of your small off-road engine.

Your emission control system may include parts such as the carburetor or fuel-injection system, the ignition system, the catalytic converter and related hoses, belts, connectors and other emission assemblies or components.

Where a warrantable condition exists, as defined herein, CLUB CAR will repair your vehicle engine at no cost to you including diagnosis, parts and labor.

#### **MANUFACTURER'S WARRANTY COVERAGE:**

This emission control system is warranted for two years from the vehicles' date of purchase. If any emission-related part on your CLUB CAR SORE is defective, the part will be repaired or replaced by CLUB CAR.

#### **OWNER'S WARRANTY RESPONSIBILITIES:**

- As the vehicle engine owner, you are responsible for the performance of the required maintenance listed in your owner's manual. CLUB CAR recommends that you retain all receipts covering maintenance on your vehicle engine, but CLUB CAR cannot deny warranty solely for the lack of receipts or for your failure to ensure the performance of all scheduled maintenance.
- As the vehicle engine owner, you should however be aware that CLUB CAR may deny you warranty coverage if vehicle engine or a part has failed due to abuse, neglect, improper maintenance or unapproved modifications.
- You are responsible for presenting vehicle engine to a CLUB CAR distribution center as soon as a problem exists. The warranty repairs should be completed in a reasonable amount of time, not to exceed 30 days. If you have any questions regarding your warranty rights and responsibilities, you should contact WARRANTY SERVICES, CLUB CAR, LLC, P.O. Box 204658, Augusta, Georgia 30917-4658, U.S.A., 1-706-863-3000.

## **CLUB CAR EXPLANATION OF EMISSION CONTROL WARRANTY:**

### **1. WARRANTY:**

CLUB CAR warrants to the ultimate purchaser and each subsequent purchaser that the SORE and related emissions equipment is designed, built and equipped so as to conform with all applicable California environmental emission regulations; and free from defects in materials and workmanship that cause the failure of a warranted part to be identical in all material respects to that part as described in CLUB CAR's application for certification with CARB. The warranty period begins on the date the engine or equipment is delivered to an ultimate purchaser or first placed into service. The warranty period is two years from the date of purchase.

### **2. COVERAGE:**

Subject to certain conditions and exclusions as stated below, the warranty on emission-related parts is as follows:

(1) Any warranted part that is not scheduled for replacement as required maintenance in the written instructions supplied, is warranted for the warranty period stated above. If the part fails during the period of warranty coverage, the part will be repaired or replaced by CLUB CAR according to subsection (4) below. Any such part repaired or replaced under warranty will be warranted for the remainder of the original warranty period.

(2) Any warranted part that is scheduled only for regular inspection in the written instructions supplied is warranted for the warranty period stated above. Any such part repaired or replaced under warranty will be warranted for the remaining original warranty period.

(3) Any warranted part that is scheduled for replacement as required maintenance in the written instructions supplied is warranted for the period of time before the first scheduled replacement date for that part. If the part fails before the first scheduled replacement, the part will be repaired or replaced by CLUB CAR according to subsection (4) below. Any such part repaired or replaced under warranty will be warranted for the remainder of the period prior to the first scheduled replacement point for the part.

(4) Repair or replacement of any warranted part under the warranty provisions herein must be performed at a warranty station\* at no charge to the owner.

(5) Notwithstanding the provisions herein, warranty services or repairs will be provided at all of our distribution centers that are franchised to service the subject engines or equipment.

(6) The engine or equipment owner will not be charged for diagnostic labor that is directly associated with diagnosis of a defective, emission-related warranted part, provided that such diagnostic work is performed at a warranty station\*.

(7) CLUB CAR is liable for damages to other engine or equipment components proximately caused by a covered failure under warranty of any warranted part.

(8) Throughout the engine or equipment warranty period stated above, CLUB CAR will maintain a supply of warranted parts sufficient to meet the expected demand for such parts.

(9) Any replacement part may be used in the performance of any warranty maintenance or repairs and must be provided without charge to the owner. Such use will not reduce the warranty obligations of CLUB CAR.

(10) Add-on or modified parts that are not exempted by the Air Resources Board may not be used. The use of any non-exempted add-on or modified parts by the ultimate purchaser will be grounds for disallowing a warranty claims. CLUB CAR will not be liable to warrant failures of warranted parts caused by the use of a non-exempted add-on or modified part.

\*CLUB CAR, its authorized dealers, or a service agency approved by CLUB CAR.

---

**ITEMS COVERED BY THIS WARRANTY:**

The repair or replacement of any warranted part otherwise eligible for warranty coverage may be excluded from such warranty coverage if CLUB CAR demonstrates that the engine or equipment has been abused, neglected, or improperly maintained, and that such abuse, neglect, or improper maintenance was the direct cause of the need for repair or replacement of the part. That notwithstanding, any adjustment of a component that has a factory installed, and properly operating, adjustment limiting device is still eligible for warranty coverage. The following emission warranty parts list are covered:

**SYSTEMS COVERED PARTS DESCRIPTION**

Fuel Metering Carburetor assembly, fuel injection pump, fuel injection nozzle, fuel regulator Exhaust Catalytic Converter, Exhaust Manifold Air Induction Air filter housing, air filter\*, crankcase breather tube Ignition Flywheel magneto, ignition pulse generator, ignition coil assembly, ignition control module, spark plug cap, spark plug\* Positive Crankcase Ventilation (PCV) System PCV valve, oil filler cap Evaporative System Fuel Tank, Fuel Cap, Fuel Lines, Fuel Line Fittings, Clamps, Pressure Relief Valves, Purge Valves, Vapor Hoses, Carbon Canister, Canister Mounting Brackets, Carbon Canister Purge Port Connector Misc. Parts Belts, hosing, tubing, fittings, seals, gaskets, clamps, and switches associated with the above systems.

Emission-related parts will vary between vehicles; therefore, certain vehicles may not include all of the listed parts or may include equivalent parts.

**3. VOIDING OF WARRANTY:**

THIS AND ANY OTHER WARRANTY SHALL BE VOID IF THE VEHICLE IS ABUSED OR USED IN AN UNINTENDED MANNER OR SHOWS INDICATIONS THAT IT HAS BEEN ALTERED IN ANY WAY, INCLUDING, BUT NOT LIMITED TO, MODIFICATION OF THE SPEED GOVERNOR, BRAKING SYSTEM, STEERING, TRANSAXLE, OR OTHER OPERATING SYSTEMS OF THE VEHICLE TO CAUSE IT TO PERFORM OUTSIDE CLUB CAR SPECIFICATIONS.

**4. HOW TO MAKE A WARRANTY CLAIM:**

To make a warranty claim under this limited warranty, you must present the vehicle or defective component to an authorized CLUB CAR dealer.

## EC DECLARATION OF CONFORMITY

When properly configured, the vehicle complies with the listed Directives.



### Declaration of Conformity

| Model Code | Model Number | Model Name            |
|------------|--------------|-----------------------|
| ME         | 104030201    | Carryall 500 Electric |
| MA         | 104030501    | Carryall 500 Gas      |
| MM         | 104030701    | Carryall 550 Electric |
| MB         | 104030801    | Carryall 550 Gas      |
| MH         | 104030901    | Carryall 700 Electric |
| ML         | 104031201    | Carryall 700 Gas      |

Serial numbers 1401000001 and greater

Four-wheel vehicles in the above series that bear the CE mark fulfill all the relevant provisions of the following Directives

Enspricht den Bestimmungen, Conforme Aux Directives, Conforme Con Las Directivas, Voldoet aan Richtlijnen, De Acordo com Directiva, Conforme Alla Diretiva, Oplylder følgende direktiver, Upplyller følgende direktiv

- 2006/42/EC Machinery
- 2006/66/EC Batteries and Accumulators and Waste Batteries and Accumulators
- 2004/108/EC Electromagnetic Compatibility

#### Standards used for verification

Standards fur Überprüfung, Normes Utilisees pour Verification, Normas Usado por Comprobacion, Waarden Aangewend voor Verificatie, Modelos Utilizado para Verificacao, Standard per la Verifica, Standarder Anvendte Nemlig Efterprøvning, Standarden Anvand for Bekraftanden

- EN 61000-6-2
- EN 61000-6-4

#### Manufacturer

Hersteller, Fabricant, Fabricante, Fabrikant, Fabricante, Fabricante, Producent, Tillverkare

Club Car, LLC  
4125 Washington Road  
Evans, Georgia 30809  
USA

#### Authorized representative and person authorized to compile the technical file

Autorisierter Händler, Representant Dument Accrédité, Representante Autorizado, Wettige Vertegenwoordiging, Representate Autorizado, Rappresentante Autorizzato, Autoriscret repræsentant, Auktoriserad representant:

Club Car Ingersoll Rand  
Alma Court Building  
Lenneke Marelaan 6  
B-1932 Sint-Stevens-Woluwe, Belgium

Geoff Stewart  
Director, Product Safety

September 17, 2013  
Evans, Georgia, USA







Publication Part Number 105062704

Edition Code 1113C0615B

This manual is valid for vehicles with build codes between 56658 and the one indicated at the top of this page.



**Club Car, LLC**  
P.O. Box 204658  
Augusta, GA 30917-4658  
USA

**Web** [www.clubcar.com](http://www.clubcar.com)  
**Phone** 1.706.863.3000  
1.800.ClubCar  
**Int'l** +1 706.863.3000  
**Fax** 1.706.863.5808