



**2006  
Transportation  
Vehicles  
Electric and Gasoline**

**Owner's Manual**

**DS Villager 4  
Villager 6  
Villager 8  
TransPorter 4  
TransPorter 6**



## NOTICE

---

The Club Car Limited Warranties appear on the last pages of this manual. No other warranties, express or implied, are contained herein. Your authorized representative checked the vehicle before it was delivered to you and will provide you a copy of the completed vehicle warranty registration form.

Club Car is not liable for errors in this manual or for incidental or consequential damages that result from the use of the material in this manual.

This manual contains proprietary information that is protected by copyright. All rights are reserved. No part of this manual may be photocopied, reproduced, or translated to another language without the written consent of Club Car, Inc.

The information contained in this document is subject to change without notice.

Club Car reserves the right to make design changes to vehicles without obligation to make these changes on units previously sold.

These vehicles do not conform to Federal Motor Vehicle Safety Standards for automobiles or to FMVSS 500 for low-speed vehicles, and are not equipped for operation on public streets, roads, or highways.



**P. O. Box 204658  
Augusta, Georgia 30917-4658 USA  
Telephone 706-863-3000  
Service Parts Fax 706-855-7413  
[www.clubcar.com](http://www.clubcar.com)**

Copyright © 2005 Club Car, Inc.  
*Club Car*, *PowerDrive*, and *ArmorFlex*  
are registered trademarks of Club Car, Inc.  
This manual effective July 25, 2005.

## FOREWORD

---

Thank you for choosing Club Car, the name most widely recognized as the industry leader in vehicle efficiency and long-lasting value. You have chosen the finest utility vehicle on the market. Please protect your investment and ensure that your Club Car vehicle(s) provides years of reliable, superior performance by reading and following the maintenance instructions in this manual.

Your comfort and safety are important to us, so we urge you to read and follow the step-by-step operating instructions and safety procedures in this manual. These instructions must be followed in order to avoid the risk of severe personal injury. If you rent or loan your vehicle to others, we recommend that you ask them to read this manual before they operate the vehicle.

Club Car products are backed by a customer support system designed to offer you fast, courteous service. In the event that your Club Car vehicle needs repairs or service, we recommend that your local authorized Club Car representative perform them. For the name and address of the Club Car representative nearest you, logon to our web site at [www.clubcar.com](http://www.clubcar.com) or call 1-800-ClubCar (258-2227). If you would prefer to write to us, direct your letter to: Club Car, Attention: Marketing Services, P.O. Box 204658, Augusta, Georgia 30917-4658 USA. Your local authorized Club Car representative can also provide technical advice, parts, and service manuals.

We hope you will consider this owner's manual a permanent part of your Club Car vehicle. If you sell the vehicle, please include the manual so that the next owner will have the important operating, safety, and maintenance information it contains.

## TABLE OF CONTENTS

---

Vehicle Feature Identification .....	4
Safety Details .....	19
General Warnings .....	19
General Information .....	22
Model Identification .....	23
Controls and Indicators .....	23
Pre-Operation and Daily Safety Checklist .....	32
Performance Inspection .....	32
Driving Instructions .....	34
Loading and Unloading .....	37
Transporting on a Trailer .....	38
Storage – Electric Vehicles .....	38
Storage – Gasoline Vehicles .....	40
Maintenance .....	43
Periodic Service Schedules .....	43
Periodic Lubrication Schedules .....	46
Vehicle Controller – Electric Vehicles .....	48
Batteries – Electric Vehicles .....	48
Battery Charger – Electric Vehicles .....	50
Battery – Gasoline Vehicles .....	54
Engine Oil – Gasoline Vehicles .....	55
Fueling Instructions – Gasoline Vehicles .....	56
Cleaning the Vehicle .....	57
Accessories .....	58
Subsequent Owner Registration .....	58
Vehicle Specifications – Electric Vehicles .....	59
Vehicle Specifications – Gasoline Vehicles .....	61

# ELECTRIC DS VILLAGER 4

**OPERATING INSTRUCTIONS**

- Read owner's manual and dash-mounted safety warnings prior to driving.
- Study and understand controls.

**TO OPERATE**

- Turn wheels to desired direction and ensure path is clear.
- Turn key to ON position.
- While stopped, place Forward/Reverse switch in desired position: F=Forward N=Neutral R=Reverse (Buzzer will sound)
- Park brake will release and vehicle will start moving when accelerator pedal is pressed.
- Slowly press accelerator pedal to increase speed.
- To stop, release accelerator pedal and press brake pedal.

**BEFORE LEAVING**

- Press park brake pedal until it locks and holds vehicle.
- Place Forward/Reverse switch in NEUTRAL position.
- Turn key OFF and remove key when not in use.

**MOTOR BRAKING**

- Electric motor braking provides speed regulation functions.
- For parked vehicle, beeping alarm indicates vehicle roll away.
- In operation, beeping alarm indicates reduction in motor braking.
- Apply brakes to further reduce vehicle speed as required.
- System is activated only when tow switch is in the RUN position.
- When towing this vehicle, tow switch must be in the TOW position.

CCI 102518001

**WARNING**

**ROLLOVER OR FALLING OFF MAY CAUSE DEATH.**

- Before using vehicle, read operating instructions.
- Remain seated and hold on to seat handle while moving.
- Do not start vehicle until all occupants are seated.
- Two (2) persons per seat maximum.
- Operate from driver side only and not on public roads.
- Keep entire body inside vehicle while moving.
- Drive slowly in turns and straight up and down slopes.
- Do not leave children unattended on vehicle.
- Never operate under the influence of alcohol or drugs.
- Use brakes to reduce speed when coasting downhill.
- Never stand in front of or behind vehicle.

CCI 101960601

**OPERATING INSTRUCTIONS  
DECAL**

**DRIVER/PASSENGER  
WARNING DECAL**

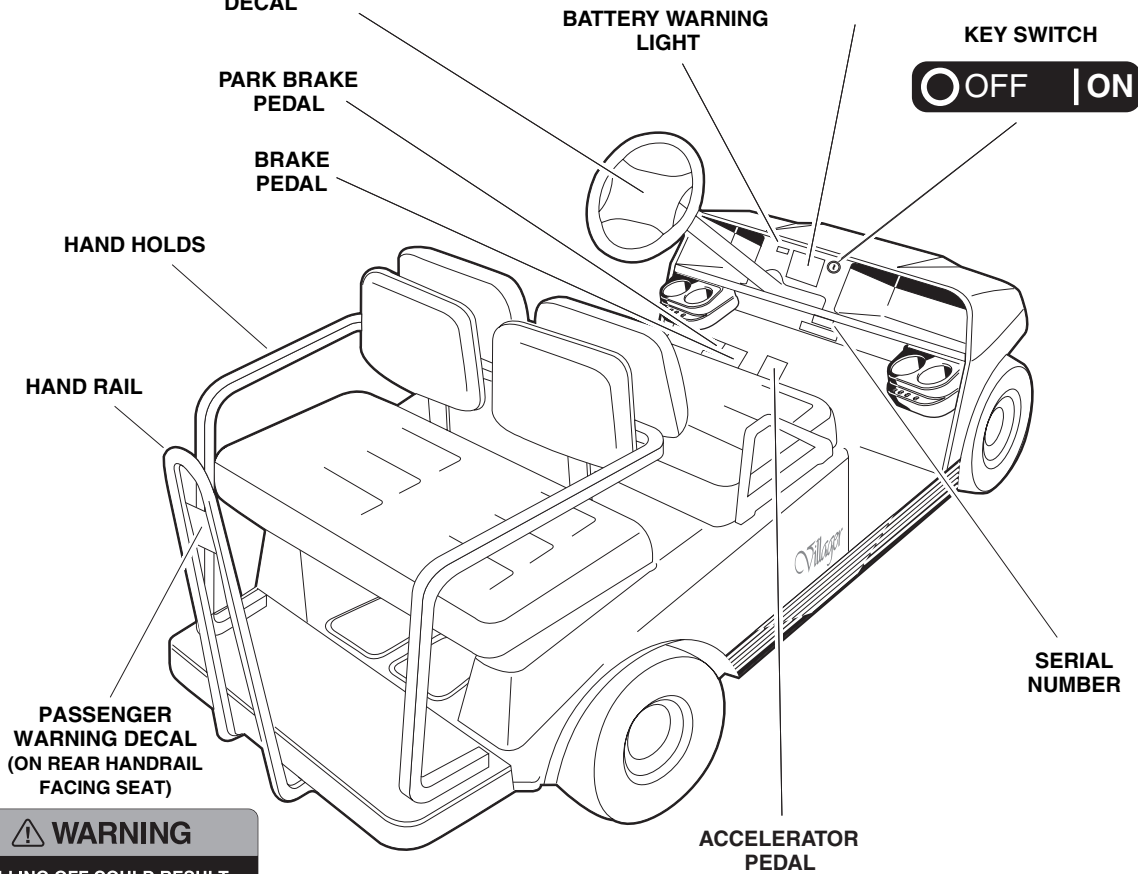

**WARNING**

**FALLING OFF COULD RESULT IN SEVERE INJURY OR DEATH**

- Remain seated with entire body inside vehicle and hold on to seat handle or handrail at all times.
- Two (2) persons per bench seat maximum.
- One (1) person per bucket seat maximum.
- Do not leave children unattended on vehicle at anytime.
- Never stand in front of or behind vehicle.

CCI 101705701

# ELECTRIC DS VILLAGER 4



**BATTERY DANGER**  
(MOLDED ON BATTERY CAPS OR  
ON BODY UNDER SEAT)

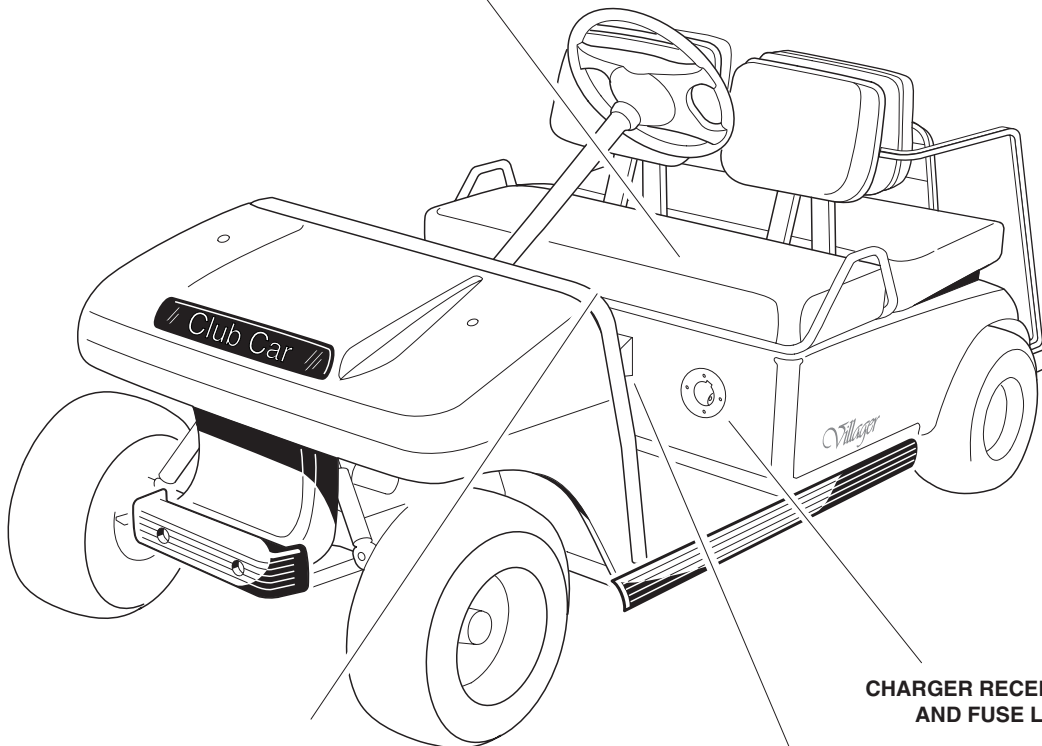

**CHARGER RECEPTACLE  
AND FUSE LINK**

**TOW/RUN WARNING DECAL**  
(IQ SYSTEM VEHICLES ONLY)  
(ON TOW SWITCH BRACKET UNDER SEAT)

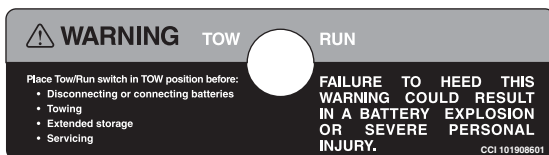

**FORWARD/REVERSE  
SWITCH**

# GASOLINE DS VILLAGER 4

**OPERATING INSTRUCTIONS**

- Read Owner's Manual and safety warnings located on dash panel prior to driving
  - Study and understand controls.
  - Make sure wheels are turned in desired direction.
- Turn key to "ON" position and be sure nothing is in your path.
- While vehicle is stopped, select direction by placing shift lever or switch in desired position:
  - F – Forward N – Neutral R – Reverse (Buzzer will sound)
- Vehicle will start moving when accelerator pedal is depressed.
- Slowly depress accelerator pedal to increase speed. Park brake will release when accelerator pedal is depressed.
- To stop, release accelerator pedal and depress brake pedal.
  - After stopping the vehicle:
    - Firmly depress park brake until it locks.
    - Place Forward/Reverse switch in "NEUTRAL" position.
    - Turn key "OFF" and remove key when not in use.

CCI 101621601

**WARNING**

**ROLLOVER OR FALLING OFF MAY CAUSE DEATH.**

- Before using vehicle, read operating instructions.
- Remain seated and hold on to seat handle while moving.
- Do not start vehicle until all occupants are seated.
- Two (2) persons per seat maximum.
- Operate from driver side only and not on public roads.
- Keep entire body inside vehicle while moving.
- Drive slowly in turns and straight up and down slopes.
- Do not leave children unattended on vehicle.
- Never operate under the influence of alcohol or drugs.
- Use brakes to reduce speed when coasting downhill.
- Never stand in front of or behind vehicle.

CCI 101960601

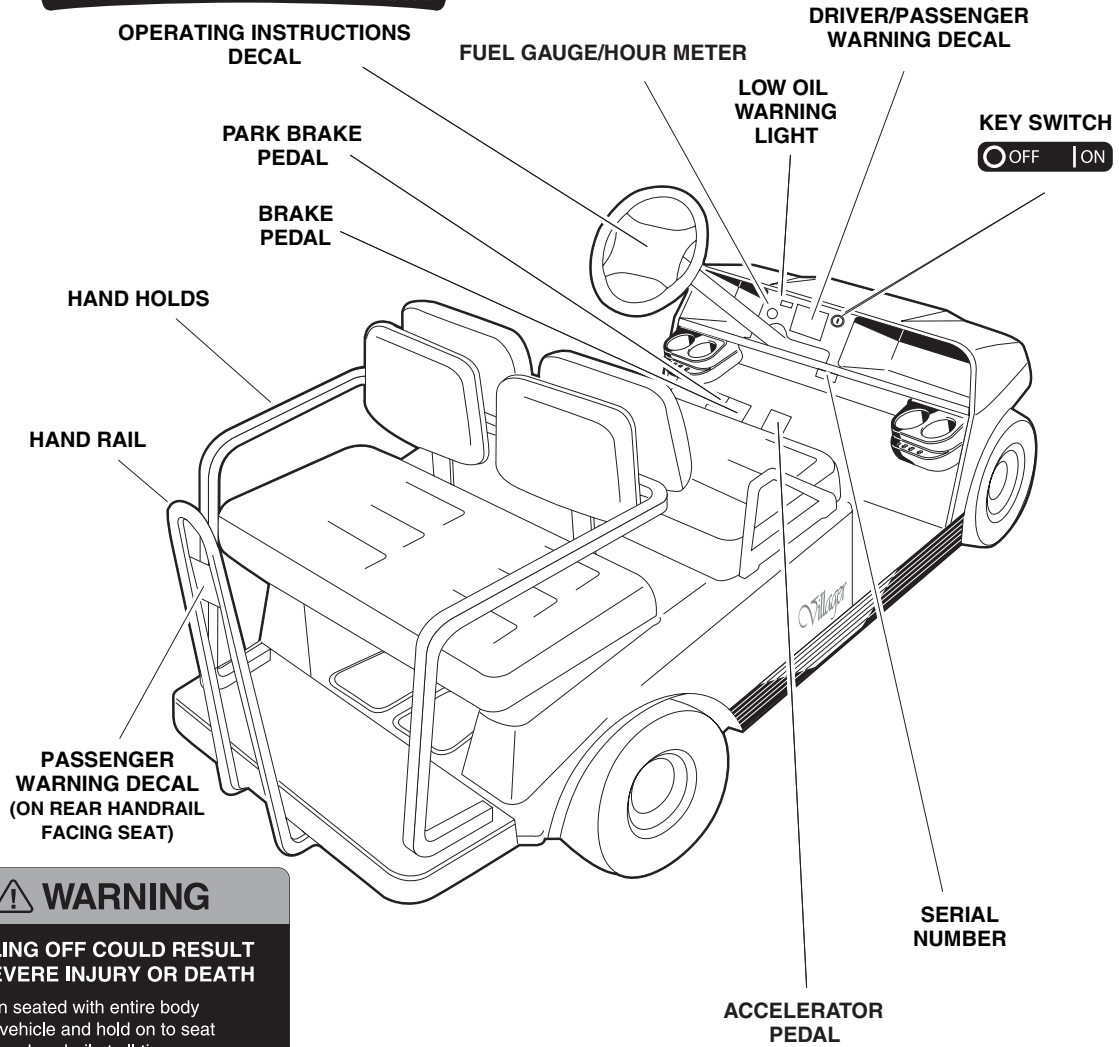

**WARNING**

**FALLING OFF COULD RESULT IN SEVERE INJURY OR DEATH**

- Remain seated with entire body inside vehicle and hold on to seat handle or handrail at all times.
- Two (2) persons per bench seat maximum.
- One (1) person per bucket seat maximum.
- Do not leave children unattended on vehicle at anytime.
- Never stand in front of or behind vehicle.

CCI 101705701

# GASOLINE DS VILLAGER 4

**WARNING**

**GASOLINE EXPLOSION / FIRE.**

- Can cause severe injury or death.
- No smoking, sparks, or open flame.
- Stop engine, allow to cool before refueling.
- Turn fuel valve (←) on during operation, (→) off during storage or transport.

CCI 101547601

**GASOLINE WARNING DECAL  
(ON VEHICLE FRAME NEAR FUEL TANK)**

**WARNING**

**CAN CAUSE SEVERE INJURY**

**Rotating parts**

**HOT manifold & muffler**

**KEEP CLEAR** CCI 101960501

**ROTATING PARTS AND  
HOT MANIFOLD DECAL  
(ON STARTER/GENERATOR  
AND ENGINE)**

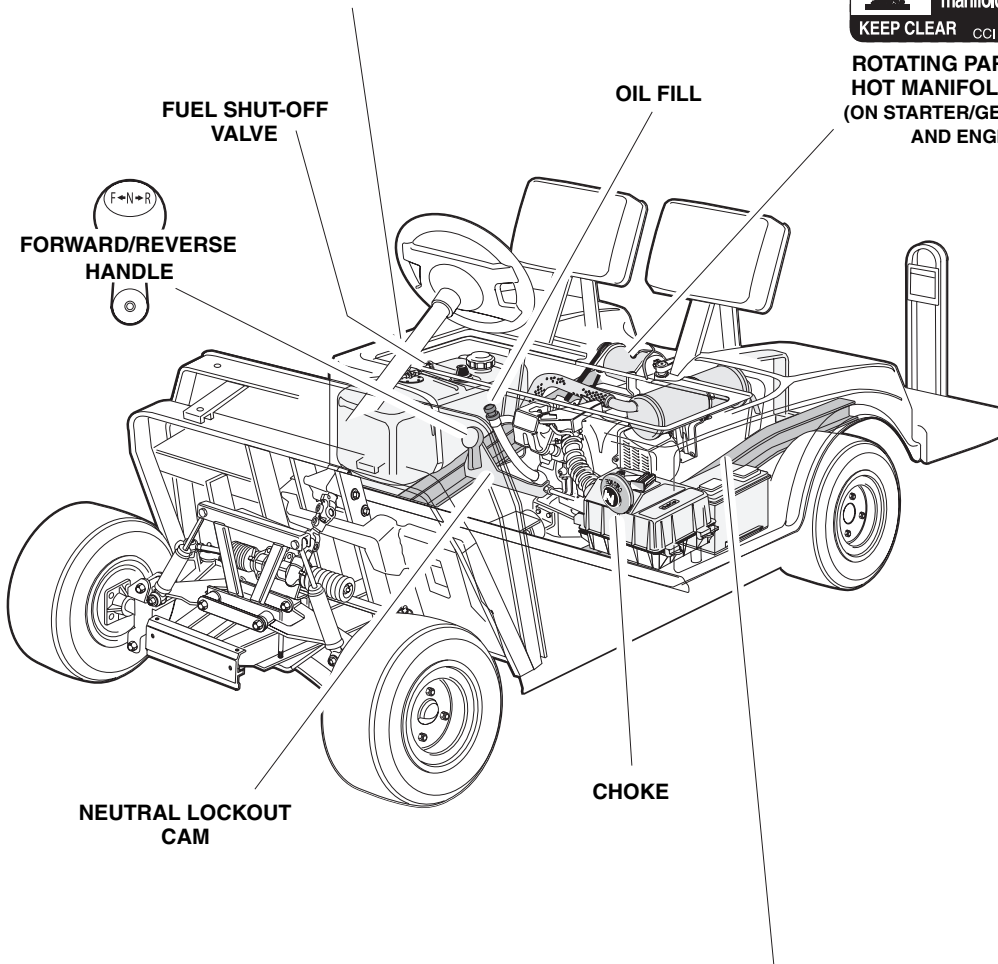

	<p><b>WARNING</b></p> <p>Negative frame ground. Can cause severe injury. Do not contact positive (+) battery post or cable to frame. Disconnect negative battery lead first.</p>		<p><b>WARNING</b></p> <p>Excessive speed. Can cause severe injury or death. Do not tamper with engine governor adjustment. CCI 101915201</p>
--	--	--	--

**FRAME GROUND AND  
GOVERNOR WARNING DECAL  
(ON VEHICLE FRAME NEAR BATTERY)**

# ELECTRIC VILLAGER 6 AND 8

**OPERATING INSTRUCTIONS**

- Read Owner's Manual and safety warnings located on dash panel prior to driving.
  - Study and understand controls.
- Make sure wheels are turned in desired direction.
- Turn key to "ON" position and be sure nothing is in your path.
- While vehicle is stopped, select direction by placing shift lever or switch in desired position:
  - F – Forward N – Neutral R – Reverse (Buzzer will sound)
- Vehicle will start moving when accelerator pedal is depressed.
- Slowly depress accelerator pedal to increase speed. Park brake will release when accelerator pedal is depressed.
- To stop, release accelerator pedal and depress brake pedal.
  - After stopping the vehicle:
    - Firmly depress park brake until it locks.
    - Place Forward/Reverse switch in "NEUTRAL" position.
    - Turn key "OFF" and remove key when not in use.

CCI 101924901

**OPERATING INSTRUCTIONS**

- Read owner's manual and dash-mounted safety warnings prior to driving.
- Study and understand controls.

**TO OPERATE**

- Turn wheels to desired direction and ensure path is clear.
- Turn key to ON position.
- While stopped, place Forward/Reverse switch in desired position:
  - F – Forward N – Neutral R – Reverse (Buzzer will sound)
- Park brake will release and vehicle will start moving when accelerator pedal is pressed.
- Slowly press accelerator pedal to increase speed.
- To stop, release accelerator pedal and press brake pedal.

**BEFORE LEAVING**

- Press park brake pedal until it locks and holds vehicle.
- Place Forward/Reverse switch in "NEUTRAL" position.
- Turn key OFF and remove key when not in use.

**MOTOR BRAKING**

- Electric motor braking provides speed regulation functions.
- For parked vehicle, beeping alarm indicates vehicle roll away.
- In operation, beeping alarm indicates reduction in motor braking.
- Apply brakes to further reduce vehicle speed as required.
- System is activated only when tow switch is in the RUN position.
- When towing this vehicle, tow switch must be in the TOW position.

CCI 102218001

**OPERATING INSTRUCTIONS  
DECAL  
(POWERDRIVE SYSTEM 48 VEHICLES)**

OR

**OPERATING INSTRUCTIONS  
DECAL  
(IQ PLUS VEHICLES)**

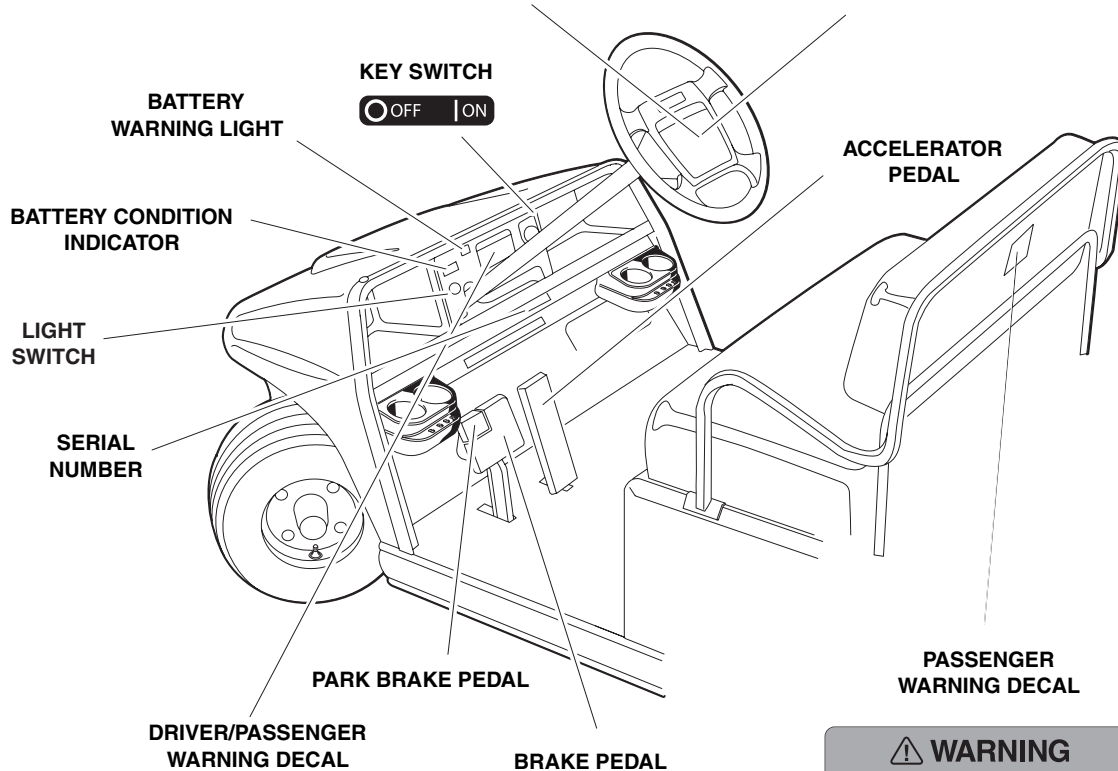

**⚠ WARNING**

**ROLLOVER OR FALLING OFF MAY CAUSE DEATH.**

- Before using vehicle, read operating instructions.
- Remain seated and hold on to seat handle while moving.
- Do not start vehicle until all occupants are seated.
- Two (2) persons per seat maximum.
- Operate from driver side only and not on public roads.
- Keep entire body inside vehicle while moving.
- Drive slowly in turns and straight up and down slopes.
- Do not leave children unattended on vehicle.
- Never operate under the influence of alcohol or drugs.
- Use brakes to reduce speed when coasting downhill.
- Never stand in front of or behind vehicle.

CCI 101960601

**⚠ WARNING**

**FALLING OFF COULD RESULT IN SEVERE INJURY OR DEATH**

- Remain seated with entire body inside vehicle and hold on to seat handle or handrail at all times.
- Two (2) persons per bench seat maximum.
- One (1) person per bucket seat maximum.
- Do not leave children unattended on vehicle at anytime.
- Never stand in front of or behind vehicle.

CCI 101705701

# ELECTRIC VILLAGER 6

**⚠ DANGER / POISON**

**EXPLOSIVE GASES CAN CAUSE BLINDNESS OR INJURY**  
SHIELD EYES

**NO**  
• SPARKS  
• FLAMES  
• SMOKING

**SULFURIC ACID**  
CAN CAUSE BLINDNESS OR SEVERE BURNS

**FLUSH EYES IMMEDIATELY WITH WATER**  
GET MEDICAL HELP FAST

KEEP OUT OF THE REACH OF CHILDREN – DO NOT TIP – KEEP VENT CAPS TIGHT AND LEVEL

**BATTERY DANGER**  
(MOLDED ON BATTERY CAPS OR ON BODY UNDER SEAT)

**⚠ WARNING**

**FALLING OFF COULD RESULT IN SEVERE INJURY OR DEATH**

- Remain seated with entire body inside vehicle and hold on to seat handle or handrail at all times.
- Two (2) persons per bench seat maximum.
- One (1) person per bucket seat maximum.
- Do not leave children unattended on vehicle at anytime.
- Never stand in front of or behind vehicle.

CCI 101705701

**⚠ WARNING**

**BATTERY EXPLOSION COULD RESULT IN SEVERE PERSONAL INJURY.**

- Do not store items in battery compartment.
- Place Run/Tow switch in TOW position before:
  - Disconnecting or connecting battery cables
  - Towing this vehicle
  - Extended storage
  - Servicing the vehicle

NORMAL      TRIPPED

TOW      RUN

CCI 102845101

**TOW/RUN WARNING DECAL**  
(IQ PLUS VEHICLES ONLY)  
(ON TOW SWITCH BRACKET UNDER PASSENGER-SIDE SEAT)

**PASSENGER WARNING DECAL**

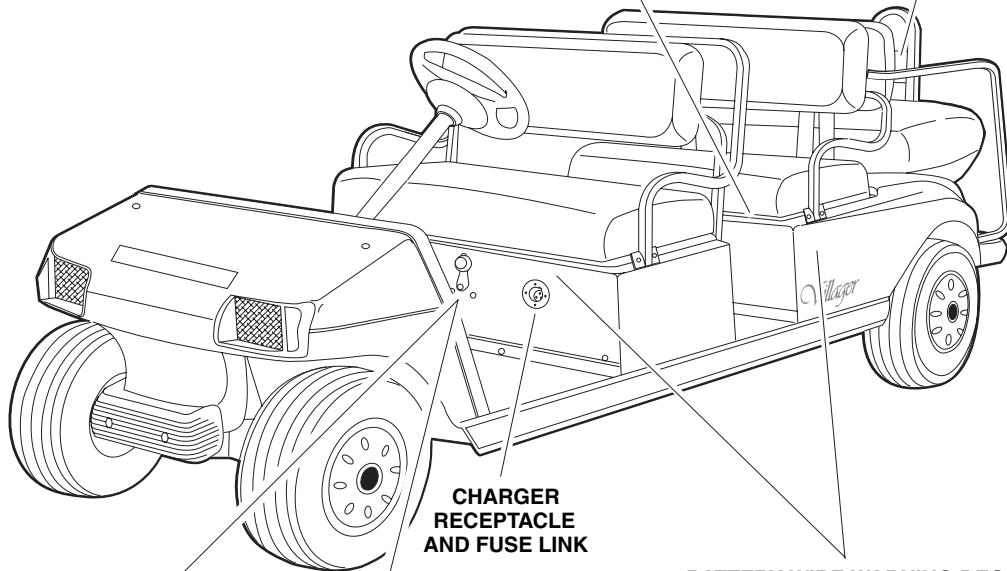

**BATTERY WIRE WARNING DECAL**  
(UNDER FRONT SEAT ON ELECTRICAL COMPONENT BOX COVER AND ON DRIVER SIDE I-BEAM UNDER SECOND SEAT)  
(IQ PLUS VEHICLES ONLY)

**OR**

**FORWARD/REVERSE HANDLE**  
(POWERDRIVE SYSTEM 48 VEHICLES)

**FORWARD/REVERSE SWITCH**  
(IQ PLUS VEHICLES)

**⚠ WARNING**

**AVOID FIRE HAZARD**

- Replacement battery wires must be 4-gauge (AWG) with low-resistance terminals equivalent to factory-installed wires.
- Ensure that battery connections are clean and properly tightened. See owner's manual.

CCI 102967601

# ELECTRIC VILLAGER 8

## TOW/RUN WARNING DECAL (IQ PLUS VEHICLES ONLY)

**⚠ WARNING**

**BATTERY EXPLOSION COULD RESULT IN SEVERE PERSONAL INJURY.**

- Do not store items in battery compartment.
- Place Run/Tow switch in TOW position before:
  - Disconnecting or connecting battery cables
  - Towing this vehicle
  - Extended storage
  - Servicing the vehicle

  
NORMAL

  
TRIPPED

  
TOW

  
RUN

CCI 102845101

(ON TOW SWITCH BRACKET UNDER PASSENGER-SIDE SEAT)

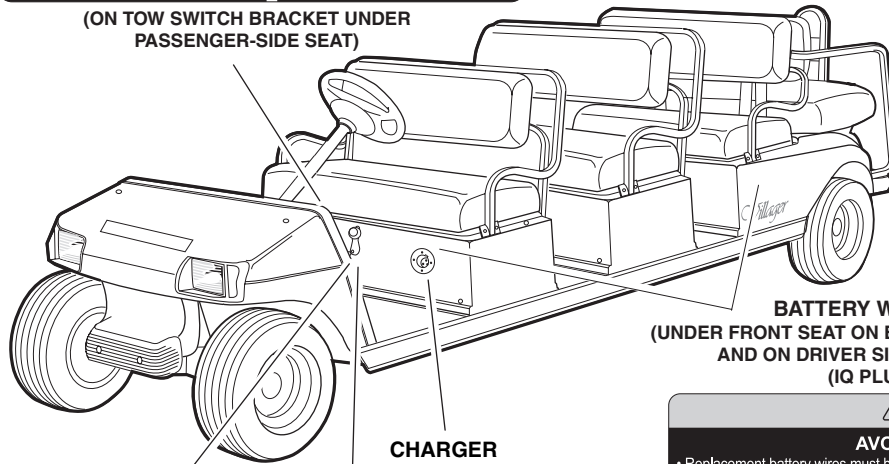

## BATTERY WIRE WARNING DECAL (UNDER FRONT SEAT ON ELECTRICAL COMPONENT BOX COVER AND ON DRIVER SIDE I-BEAM UNDER THIRD SEAT) (IQ PLUS VEHICLES ONLY)

**⚠ WARNING**

**AVOID FIRE HAZARD**

- Replacement battery wires must be 4-gauge (AWG) with low-resistance terminals equivalent to factory-installed wires.
- Ensure that battery connections are clean and properly tightened. See owner's manual.

CCI 102967601

## CHARGER RECEPTACLE

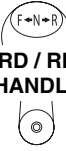
  
**FORWARD / REVERSE HANDLE**  
 (POWERDRIVE SYSTEM 48 VEHICLES)

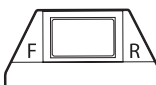
**OR**  
  
**FORWARD/REVERSE SWITCH**  
 (IQ PLUS VEHICLES)

**⚠ WARNING**

**FALLING OFF COULD RESULT IN SEVERE INJURY OR DEATH**

- Remain seated with entire body inside vehicle and hold on to seat handle or handrail at all times.
- Two (2) persons per bench seat maximum.
- One (1) person per bucket seat maximum.
- Do not leave children unattended on vehicle at anytime.
- Never stand in front of or behind vehicle.

CCI 101700701

## PASSENGER WARNING DECAL

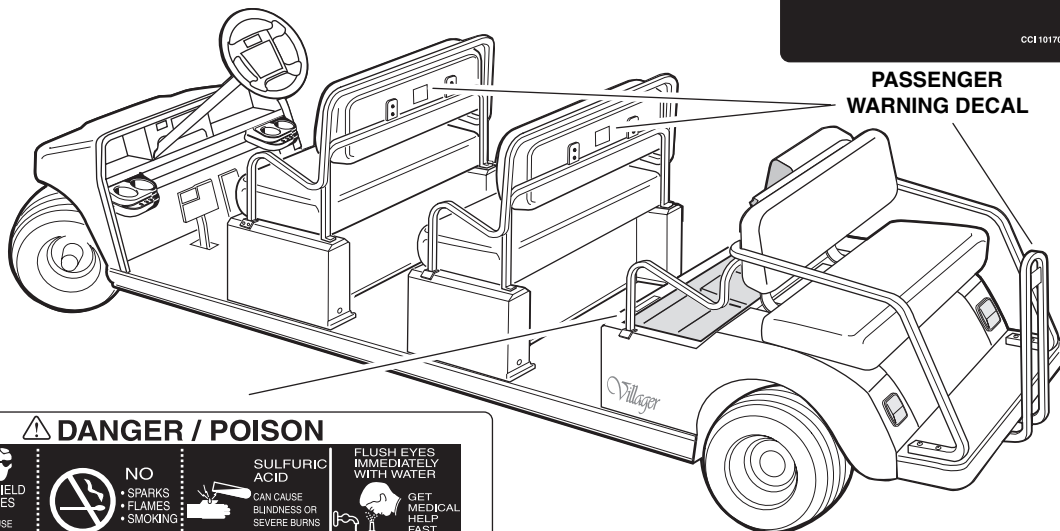

**⚠ DANGER / POISON**

  
EXPLOSIVE GASES CAN CAUSE BLINDNESS OR INJURY

  
SHIELD EYES

  
NO SPARKS • FLAMES • SMOKING

  
SULFURIC ACID CAN CAUSE BLINDNESS OR SEVERE BURNS

  
FLUSH EYES IMMEDIATELY WITH WATER

  
GET MEDICAL HELP FAST

KEEP OUT OF THE REACH OF CHILDREN – DO NOT TIP – KEEP VENT CAPS TIGHT AND LEVEL

## BATTERY DANGER (MOLDED ON BATTERY CAPS OR ON BODY UNDER SEAT)

# GASOLINE VILLAGER 6 AND 8

**WARNING**

**ROLLOVER OR FALLING OFF MAY CAUSE DEATH.**

- Before using vehicle, read operating instructions.
- Remain seated and hold on to seat handle while moving.
- Do not start vehicle until all occupants are seated.
- Two (2) persons per seat maximum.
- Operate from driver side only and not on public roads.
- Keep entire body inside vehicle while moving.
- Drive slowly in turns and straight up and down slopes.
- Do not leave children unattended on vehicle.
- Never operate under the influence of alcohol or drugs.
- Use brakes to reduce speed when coasting downhill.
- Never stand in front of or behind vehicle.

CCI 101960601

**DRIVER / PASSENGER  
WARNING DECAL**

**OPERATING INSTRUCTIONS**

- Read Owner's Manual and safety warnings located on dash panel prior to driving.
- Study and understand controls.

**TO START ENGINE**

- Place shift lever in "N" - Neutral position.
- Depress brake pedal.
- Turn key switch to "START" position and release.

**TO OPERATE VEHICLE**

- Make sure wheels are turned in desired direction.
- Be sure nothing is in your path.
- While vehicle is stopped, and engine is at idle, select vehicle direction by placing shift lever or switch in desired position.

F - Forward    N - Neutral    R - Reverse (Buzzer will sound)

- Park brake will release when accelerator pedal is pushed.
- Slowly push accelerator pedal to increase speed.
- Engine must be at idle before moving shift lever.

**TO STOP VEHICLE**

- Release accelerator pedal and push brake pedal.
- After stopping, firmly push park brake until it locks.
- Turn key to "OFF" position, remove key and place shift lever in straight up neutral position when not in use.

CCI 101693201

**OPERATING INSTRUCTIONS  
DECAL**

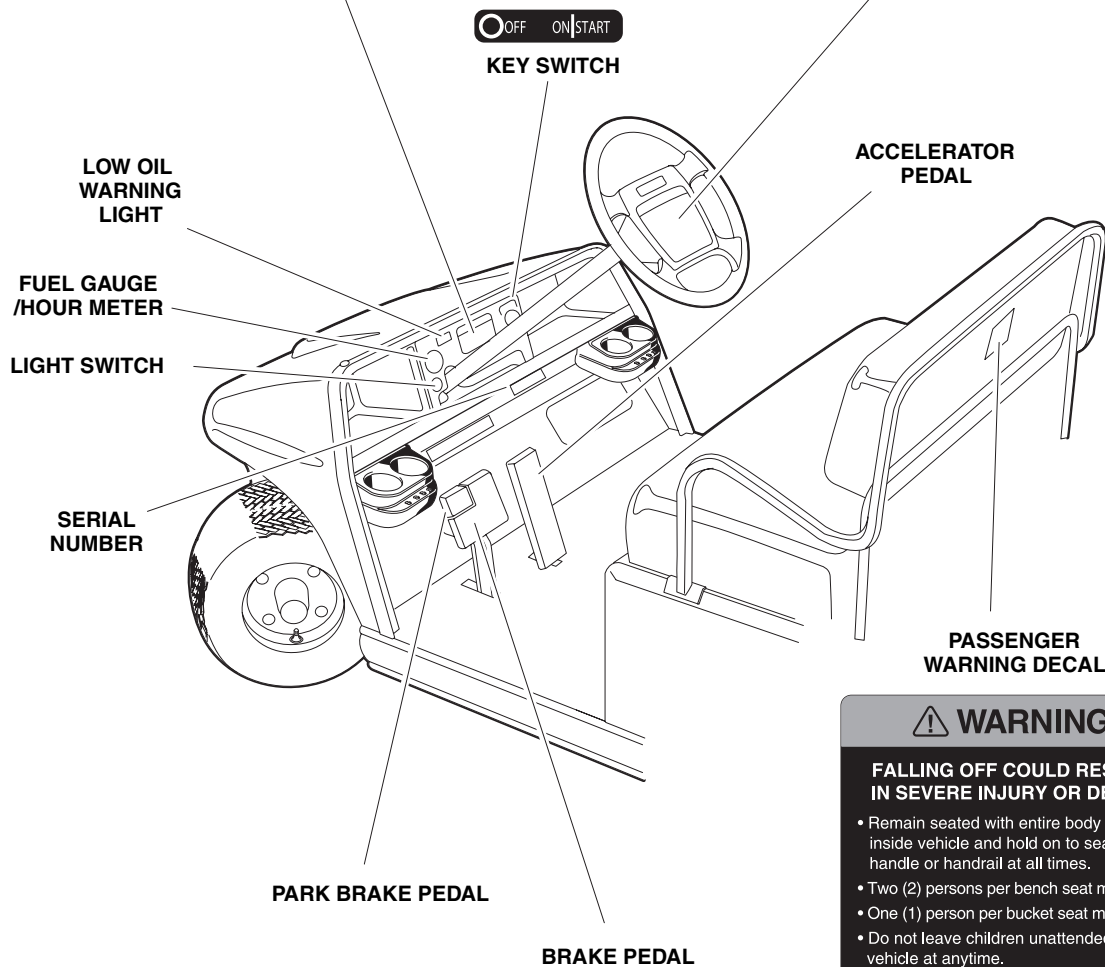

**WARNING**

**FALLING OFF COULD RESULT IN SEVERE INJURY OR DEATH**

- Remain seated with entire body inside vehicle and hold on to seat handle or handrail at all times.
- Two (2) persons per bench seat maximum.
- One (1) person per bucket seat maximum.
- Do not leave children unattended on vehicle at anytime.
- Never stand in front of or behind vehicle.

CCI 101705701

# GASOLINE VILLAGER 6

**⚠ WARNING**

**GASOLINE EXPLOSION / FIRE.**

- Can cause severe injury or death.
- No smoking, sparks, or open flame.
- Stop engine, allow to cool before refueling.
- Turn fuel valve (←) on during operation. (→) off during storage or transport.

CCI 101547601

**GASOLINE WARNING DECAL  
(ON VEHICLE FRAME NEAR FUEL TANK)**

**⚠ WARNING**

**CAN CAUSE SEVERE INJURY**

**Rotating parts**

**HOT**  
manifold & muffler

**KEEP CLEAR** CCI 101960501

**ROTATING PARTS AND  
HOT MANIFOLD DECAL  
(ON STARTER/GENERATOR  
AND ENGINE)**

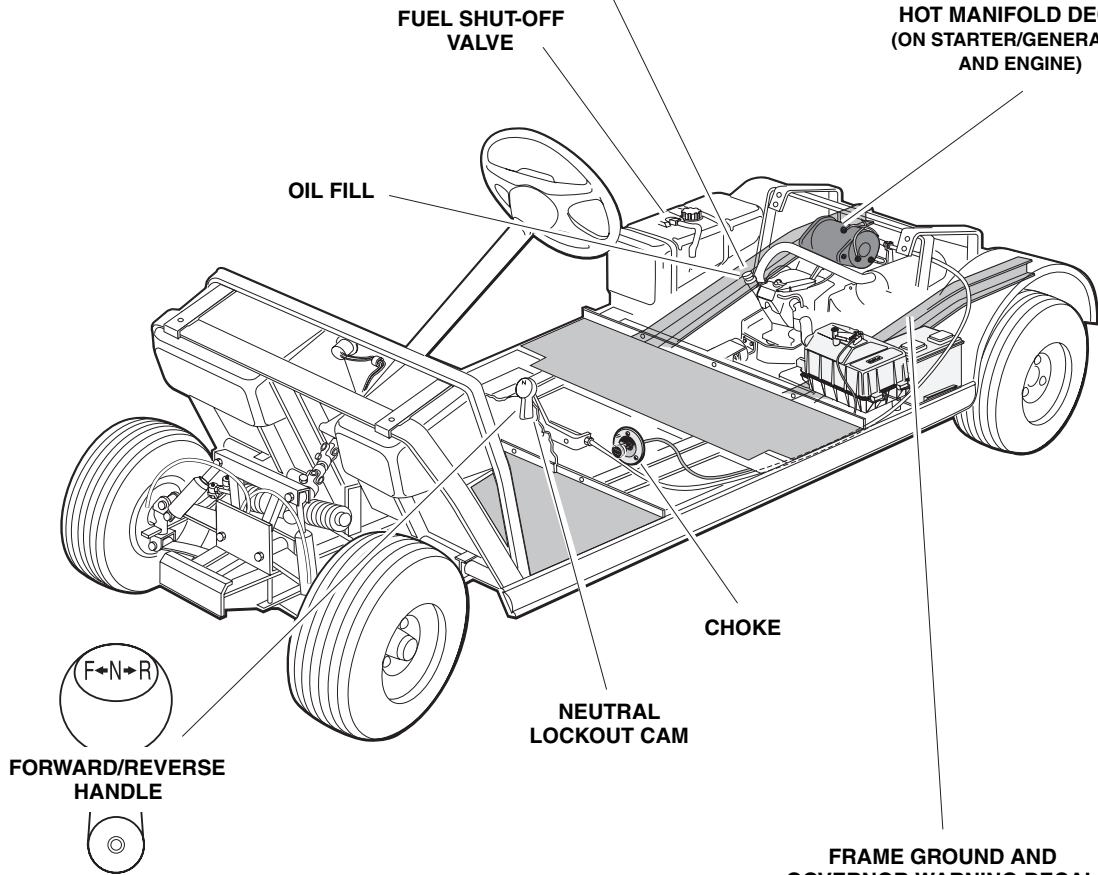

**FRAME GROUND AND  
GOVERNOR WARNING DECAL  
(ON VEHICLE FRAME  
NEAR BATTERY)**

	<p><b>⚠ WARNING</b></p> <p>Negative frame ground. Can cause severe injury. Do not contact positive (+) battery post or cable to frame. Disconnect negative battery lead first.</p>		<p><b>⚠ WARNING</b></p> <p>Excessive speed. Can cause severe injury or death. Do not tamper with engine governor adjustment. CCI 1019152-01</p>
--	--	--	---

# GASOLINE VILLAGER 8

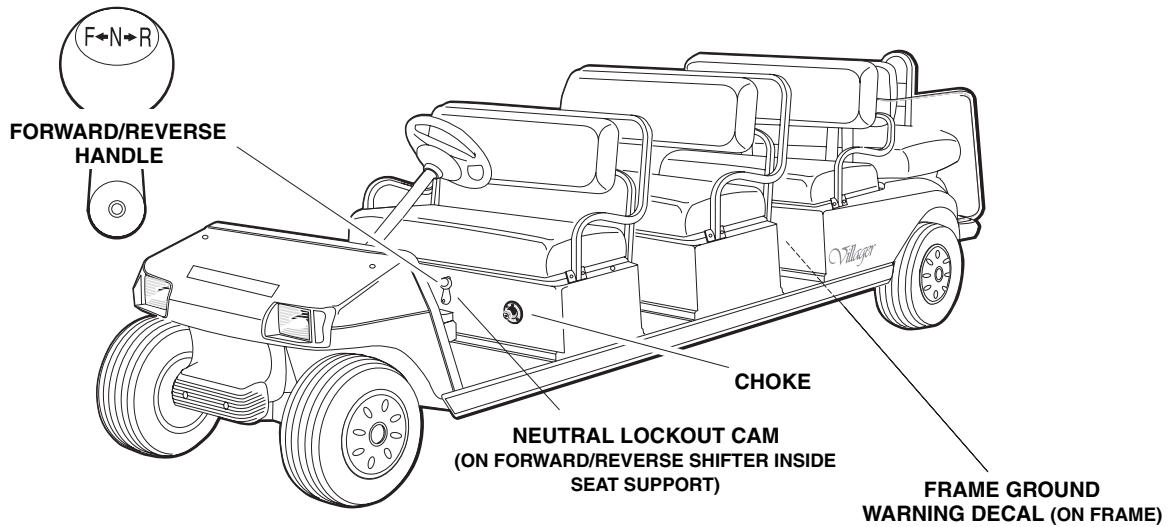

	<p><b>WARNING</b></p> <p>Negative frame ground. Can cause severe injury. Do not contact positive (+) battery post or cable to frame. Disconnect negative battery lead first.</p>		<p><b>WARNING</b></p> <p>Excessive speed. Can cause severe injury or death. Do not tamper with engine governor adjustment. CCI 1019152-01</p>
--	--	--	---

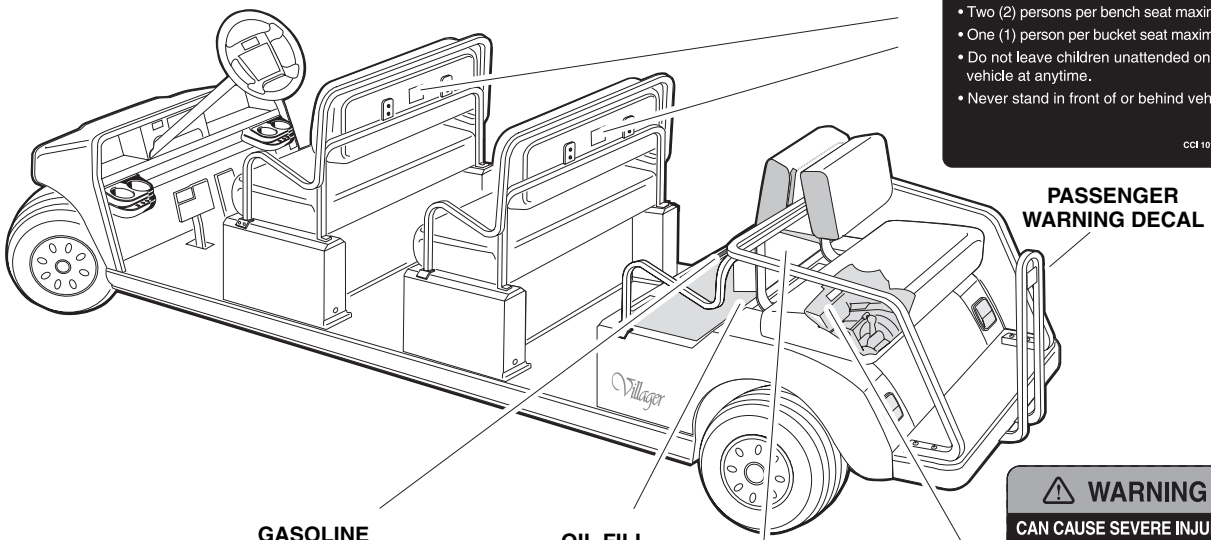

**WARNING**

**FALLING OFF COULD RESULT IN SEVERE INJURY OR DEATH**

- Remain seated with entire body inside vehicle and hold on to seat handle or handrail at all times.
- Two (2) persons per bench seat maximum.
- One (1) person per bucket seat maximum.
- Do not leave children unattended on vehicle at anytime.
- Never stand in front of or behind vehicle.

CCI 101705701

**WARNING**

**GASOLINE EXPLOSION / FIRE.**

- Can cause severe injury or death.
- No smoking, sparks, or open flame.
- Stop engine, allow to cool before refueling.
- Turn fuel valve (←) on during operation. (→) off during storage or transport.

CCI 101547601

**WARNING**

**CAN CAUSE SEVERE INJURY**

**Rotating parts**

**HOT manifold & muffler**

**KEEP CLEAR** CCI 101960501

**ROTATING PARTS AND HOT MANIFOLD DECAL (ON STARTER/GENERATOR AND ENGINE)**

# ELECTRIC TRANSPORTER

**WARNING**

**ROLLOVER OR FALLING OFF MAY CAUSE DEATH.**

- Before using vehicle, read operating instructions.
- Remain seated and hold on to seat handle while moving.
- Do not start vehicle until all occupants are seated.
- Two (2) persons per seat maximum.
- Operate from driver side only and not on public roads.
- Keep entire body inside vehicle while moving.
- Drive slowly in turns and straight up and down slopes.
- Do not leave children unattended on vehicle.
- Never operate under the influence of alcohol or drugs.
- Use brakes to reduce speed when coasting downhill.
- Never stand in front of or behind vehicle.

CCI 101960601

**OPERATING INSTRUCTIONS**

- Read Owner's Manual and safety warnings located on dash panel prior to driving.
  - Study and understand controls.
- Make sure wheels are turned in desired direction.
- Turn key to "ON" position and be sure nothing is in your path.
- While vehicle is stopped, select direction by placing shift lever or switch in desired position:
  - F - Forward N - Neutral R - Reverse (Buzzer will sound)
- Vehicle will start moving when accelerator pedal is depressed.
- Slowly depress accelerator pedal to increase speed. Park brake will release when accelerator pedal is depressed.
- To stop, release accelerator pedal and depress brake pedal.
  - After stopping the vehicle:
    - Firmly depress park brake until it locks.
    - Place Forward/Reverse switch in "NEUTRAL" position.
    - Turn key "OFF" and remove key when not in use.

CCI 101960601

**OPERATING INSTRUCTIONS DECAL  
(POWERDRIVE SYSTEM 48 VEHICLES)**

**OPERATING INSTRUCTIONS**

- Read owner's manual and dash-mounted safety warnings prior to driving.
  - Study and understand controls.
- TO OPERATE**
  - Turn wheels to desired direction and ensure path is clear.
  - Turn key to ON position.
  - While stopped, place Forward/Reverse switch in desired position:
    - F - Forward N - Neutral R - Reverse (Buzzer will sound)
  - Park brake will release and vehicle will start moving when accelerator pedal is pressed.
  - Slowly press accelerator pedal to increase speed.
  - To stop, release accelerator pedal and press brake pedal.
- BEFORE LEAVING**
  - Press park brake pedal until it locks and holds vehicle.
  - Place Forward/Reverse switch in NEUTRAL position.
  - Turn key OFF and remove key when not in use.
- MOTOR BRAKING**
  - Electric motor braking provides speed regulation functions.
  - For parked vehicle, beeping alarm indicates vehicle roll away.
  - In operation, beeping alarm indicates reduction in motor braking.
  - Apply brakes to further reduce vehicle speed as required.
  - System is activated only when tow switch is in the TOW position.
  - When towing this vehicle, tow switch must be in the TOW position.

CCI 102519001

**OPERATING INSTRUCTIONS DECAL  
(IQ PLUS VEHICLES)**

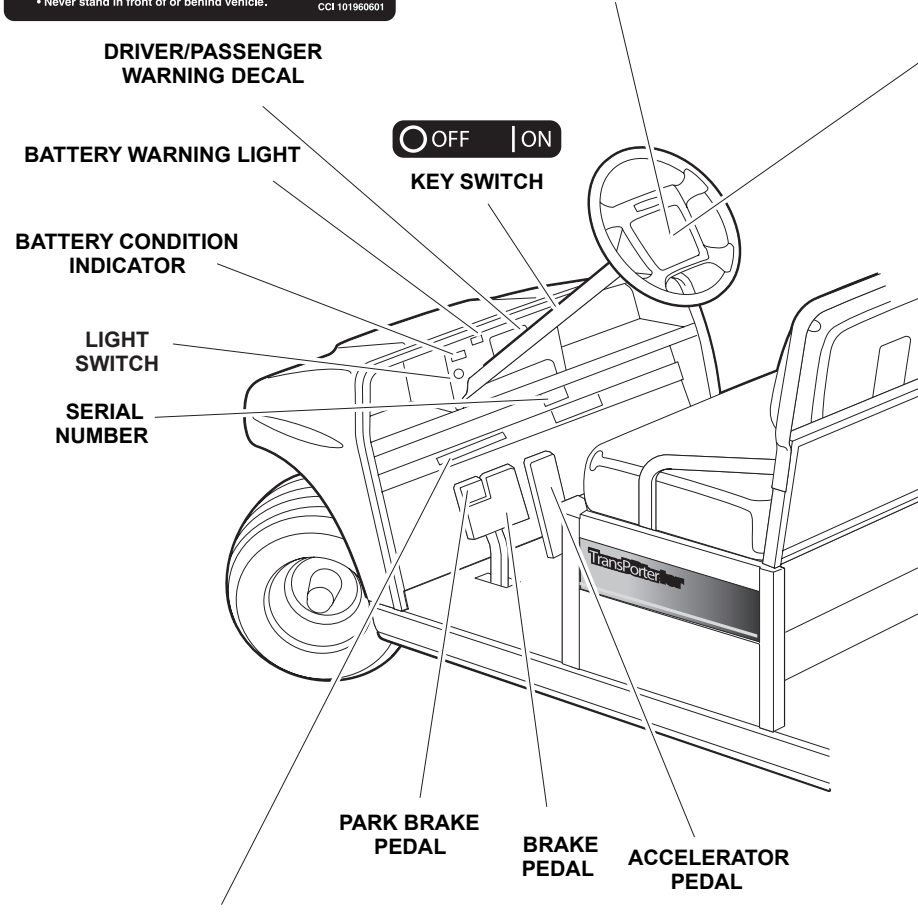

**VEHICLE LOADING**

Read Owner's Manual and warnings on dash.

- Vehicle rated capacity - 1500 lbs. on level surface only. Weight to include passengers, cargo bed load, and gross trailer weight. See Owner's Manual.
- Maximum cargo load CARRYALL 6 and TURF 6 - 1000 lbs., TRANSPORTER - 300 LBS. Weight to include cargo bed load and gross trailer weight.
- Maximum trailer hitch tongue weight - 150 lbs.

- Cargo should be evenly spread over the floor of the cargo bed as far forward as possible and secured.
- For vehicle stability, when fully loaded, drive slowly and avoid stopping on or backing down steep hills.
- Avoid top heavy loads. See Owner's Manual.
- When driving on uneven terrain or down steep hills, reduce speed and load.

CCI 101960001

# ELECTRIC TRANSPORTER

**WARNING**

**BATTERY EXPLOSION COULD RESULT IN SEVERE PERSONAL INJURY.**

- Do not store items in battery compartment.
- Place Run/Tow switch in TOW position before:
  - Disconnecting or connecting battery cables
  - Towing this vehicle
  - Extended storage
  - Servicing the vehicle

NORMAL TOW TRIPPED

TOW RUN

CCI 102845101

**TOW/RUN WARNING DECAL**  
(IQ PLUS VEHICLES ONLY)  
(ON TOW SWITCH BRACKET UNDER PASSENGER-SIDE SEAT)

**NOTICE**

Do not operate vehicle without this cover properly installed. Do not direct water stream in this area, will cause damage to components. See vehicle maintenance and service manual before servicing.

CCI 101931501

**ELECTRICAL COMPONENT COVER CAUTION**  
(ON COVER)

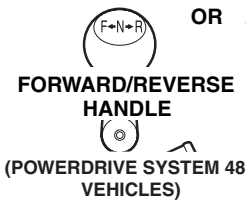

**NOTICE**

**DO NOT USE AS GROUND**

CCI 1019646-01

**ELECTRICAL COMPONENT MOUNTING PLATE NOTICE**  
(ON PLATE)

**DANGER / POISON**

EXPLOSIVE GASES CAN CAUSE BLINDNESS OR INJURY. SHIELD EYES. NO SPARKS, FLAMES, SMOKING. SULFURIC ACID CAN CAUSE BLINDNESS OR SEVERE BURNS. FLUSH EYES IMMEDIATELY WITH WATER. GET MEDICAL HELP FAST.

KEEP OUT OF THE REACH OF CHILDREN - DO NOT TIP - KEEP VENT CAPS TIGHT AND LEVEL

**BATTERY DANGER**  
(MOLDED ON BATTERY CAPS)

**SIX-PASSENGER TRANSPORTER VEHICLE**

**PASSENGER WARNING DECAL**

**BATTERY WIRE WARNING DECAL**  
(UNDER SEAT ON CENTER OF PANEL & ON PASSENGER SIDE I-BEAM)  
(IQ VEHICLES ONLY)

**CHARGER AC CORD REEL**

**WARNING**

**AVOID FIRE HAZARD**

- Replacement battery wires must be 4-gauge (AWG) with low-resistance terminals equivalent to factory-installed wires.
- Ensure that battery connections are clean and properly tightened. See owner's manual.

CCI 102967601

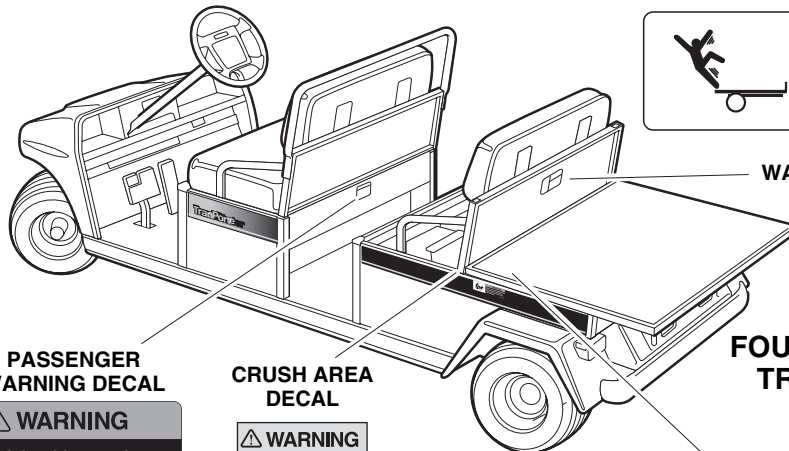

**WARNING**

Riding in cargo bed can cause severe injury or death. Do not ride in cargo bed.

CCI 1015539-01

**BED LOAD WARNING DECAL**

**FOUR-PASSENGER TRANSPORTER VEHICLE**

**WARNING**

**FALLING OFF COULD RESULT IN SEVERE INJURY OR DEATH**

- Remain seated with entire body inside vehicle and hold on to seat handle or handrail at all times.
- Two (2) persons per bench seat maximum.
- One (1) person per bucket seat maximum.
- Do not leave children unattended on vehicle at anytime.
- Never stand in front of or behind vehicle.

CCI 101705701

**WARNING**

**CRUSH AREA**

**STAY CLEAR**

CCI 101609401

**BED BOLT WARNING DECAL**

**WARNING**

FAILURE TO FOLLOW THESE INSTRUCTIONS CAN CAUSE SEVERE INJURY OR DEATH. Bed can tip up unexpectedly. Bed hold down bolts must be fastened.

CCI 101707801

# GASOLINE TRANSPORTER

**WARNING**

**ROLLOVER OR FALLING OFF MAY CAUSE DEATH.**

- Before using vehicle, read operating instructions.
- Remain seated and hold on to seat handle while moving.
- Do not start vehicle until all occupants are seated.
- Two (2) persons per seat maximum.
- Operate from driver side only and not on public roads.
- Keep entire body inside vehicle while moving.
- Drive slowly in turns and straight up and down slopes.
- Do not leave children unattended on vehicle.
- Never operate under the influence of alcohol or drugs.
- Use brakes to reduce speed when coasting downhill.
- Never stand in front of or behind vehicle.

CCI 101960601

**OPERATING INSTRUCTIONS**

- Read Owner's Manual and safety warnings located on dash panel prior to driving.
- Study and understand controls.

**TO START ENGINE**

- Place shift lever in "N" - Neutral position.
- Depress brake pedal.
- Turn key switch to "START" position and release.

**TO OPERATE VEHICLE**

- Make sure wheels are turned in desired direction.
- Be sure nothing is in your path.
- While vehicle is stopped, and engine is at idle, select vehicle direction by placing shift lever or switch in desired position.

F - Forward    N - Neutral    R - Reverse (Buzzer will sound)

- Park brake will release when accelerator pedal is pushed.
- Slowly push accelerator pedal to increase speed.
- Engine must be at idle before moving shift lever.

**TO STOP VEHICLE**

- Release accelerator pedal and push brake pedal.
- After stopping, firmly push park brake until it locks.
- Turn key to "OFF" position, remove key and place shift lever in straight up neutral position when not in use.

CCI 101693201



**DRIVER/PASSENGER WARNING DECAL**

**OPERATING INSTRUCTIONS DECAL**

**LOW OIL WARNING LIGHT**

**SERIAL NUMBER**

**FUEL GAUGE / HOUR METER**

**LIGHT SWITCH**

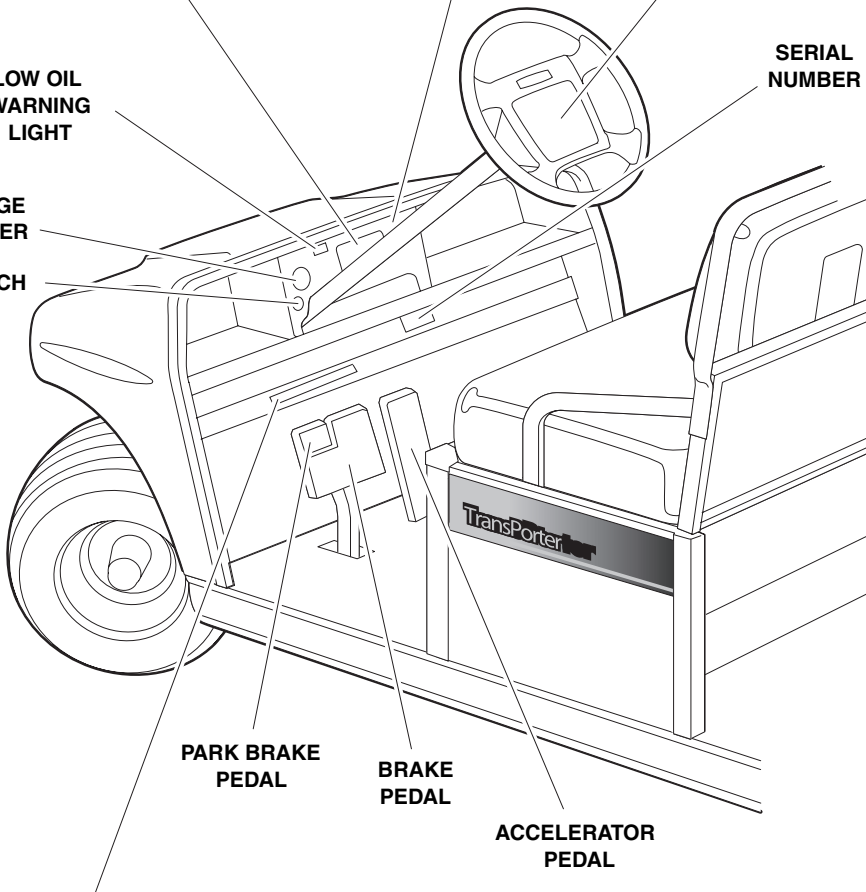

**PARK BRAKE PEDAL**

**BRAKE PEDAL**

**ACCELERATOR PEDAL**

**VEHICLE LOADING DECAL**

<p><b>VEHICLE LOADING</b></p> <p>Read Owner's Manual and warnings on dash.</p>	<ul style="list-style-type: none"> <li>• Vehicle rated capacity - 1500 lbs. on level surface only. Weight to include passengers, cargo bed load, and gross trailer weight. See Owner's Manual.</li> <li>• Maximum cargo load CARRYALL 6 and TURF 6 - 1000 lbs., TRANSPORTER - 300 LBS. Weight to include cargo bed load and gross trailer weight.</li> <li>• Maximum trailer hitch tongue weight - 150 lbs.</li> </ul>	<ul style="list-style-type: none"> <li>• Cargo should be evenly spread over the floor of the cargo bed as far forward as possible and secured.</li> <li>• For vehicle stability, when fully loaded, drive slowly and avoid stopping on or backing down steep hills.</li> <li>• Avoid top heavy loads. See Owner's Manual.</li> <li>• When driving on uneven terrain or down steep hills, reduce speed and load.</li> </ul> <p>CCI 101960001</p>
--	--	---

# GASOLINE TRANSPORTER

**⚠ WARNING**  
**GASOLINE EXPLOSION / FIRE.**

- Can cause severe injury or death.
- No smoking, sparks, or open flame.
- Stop engine, allow to cool before refueling.
- Turn fuel valve (←) on during operation. (→) off during storage or transport.

CCI 101547601

**⚠ WARNING**  
**CAN CAUSE SEVERE INJURY**

**Rotating parts**

**HOT manifold & muffler**

**KEEP CLEAR** CCI 101960501

**⚠ WARNING**  
**FALLING OFF COULD RESULT IN SEVERE INJURY OR DEATH**

- Remain seated with entire body inside vehicle and hold on to seat handle or handrail at all times.
- Two (2) persons per bench seat maximum.
- One (1) person per bucket seat maximum.
- Do not leave children unattended on vehicle at anytime.
- Never stand in front of or behind vehicle.

CCI 101705701

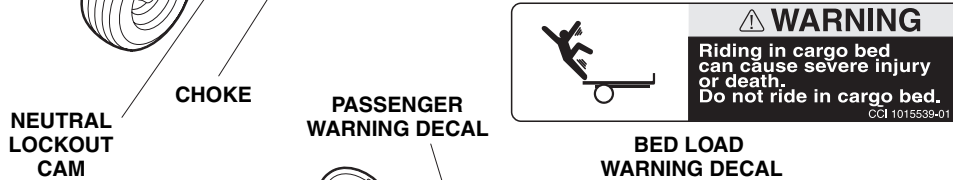
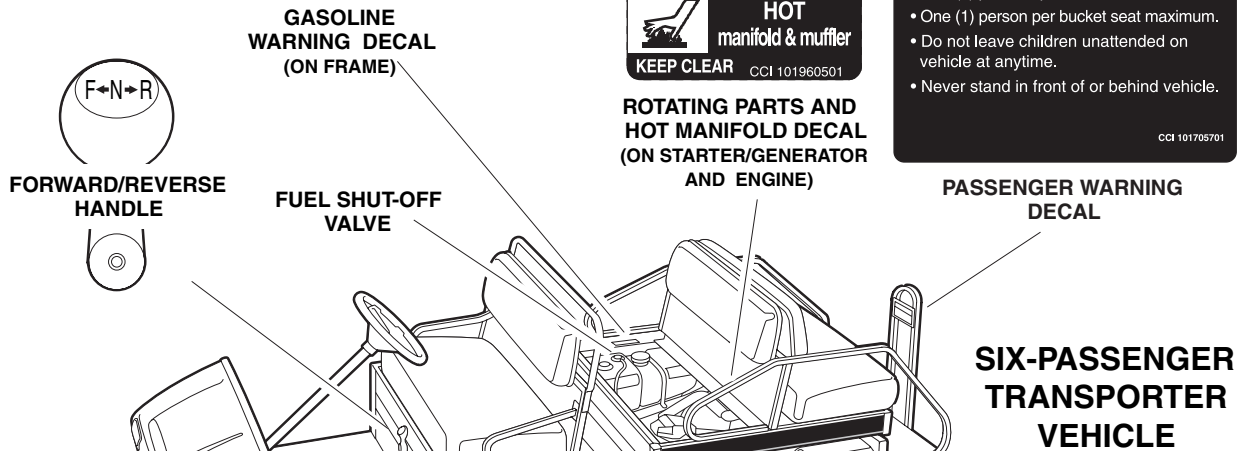

**⚠ WARNING**  
**Riding in cargo bed can cause severe injury or death. Do not ride in cargo bed.**

CCI 1015539-01

**⚠ WARNING**  
**CRUSH AREA**

**STAY CLEAR**

CCI 101609401

**CRUSH AREA DECAL**

**⚠ WARNING**  
**FAILURE TO FOLLOW THESE INSTRUCTIONS CAN CAUSE SEVERE INJURY OR DEATH. Bed can tip up unexpectedly. Bed hold down bolts must be fastened.**

CCI 101707801

	<p><b>⚠ WARNING</b></p> <p>Negative frame ground. Can cause severe injury. Do not contact positive (+) battery post or cable to frame. Disconnect negative battery lead first.</p>		<p><b>⚠ WARNING</b></p> <p>Excessive speed. Can cause severe injury or death. Do not tamper with engine governor adjustment.</p> <p>CCI 1019152-01</p>
--	--	--	--

# Practice Safety



Safety signs like you see above may at first seem shocking, but their impact is mild compared with the reality of severe personal injury.

Your safety and satisfaction are of the utmost importance to Club Car. That is why before operating the vehicle, we urge you to review the information in this manual. Understand and become familiar with the DANGER, WARNING and CAUTION statements and procedures it contains, along with the safety decals that are affixed to your vehicle.

Take time to understand the language of safety. It is a language that can save your life.

## PROPOSITION 65 - STATE OF CALIFORNIA

---

### **▲ WARNING**

This product contains or emits chemicals or substances that have been determined by the state of California to cause cancer and birth defects or other reproductive harm.

---

## SAFETY DETAILS

---

### **WARNING**

- This owner's manual should be read completely before attempting to drive or service the vehicle. Failure to follow the instructions in this manual could result in property damage, severe personal injury, or death.

It is important to note that some vital statements throughout this manual and on the decals affixed to the vehicle are preceded by the words DANGER, WARNING, or CAUTION. For your protection, we recommend that you take special notice of these safety precautions. Safety precautions are essential and must be followed.

If any of the operation or safety decals on the vehicle become damaged, have been removed, or cannot be easily read, they should be replaced immediately to avoid possible property damage, personal injury, or death. Contact your Club Car distributor/dealer.

### **DANGER**

- A DANGER indicates an immediate hazard that will result in severe personal injury or death.

### **WARNING**

- A WARNING indicates an immediate hazard that could result in severe personal injury or death.

### **CAUTION**

- A CAUTION with the safety alert symbol indicates a hazard or unsafe practice that could result in minor personal injury.

### **CAUTION**

- A CAUTION without the safety alert symbol indicates a potentially hazardous situation that could result in property damage.

---

## GENERAL WARNINGS

---

The following safety statements must be heeded whenever the vehicle is being operated, repaired, or serviced. Vehicle feature identification information is also included beginning on page 4. Other specific safety statements appear throughout this manual and on the vehicle.

### **DANGER**

- **Battery – Explosive gases! Do not smoke. Keep sparks and flames away from the vehicle and service area. Ventilate when charging or operating vehicle in an enclosed area. Wear a full face shield and rubber gloves when working on or near batteries.**
- **Gasoline – Flammable! Explosive! Do not smoke. Keep sparks and flames away from the vehicle and service area. Service only in a well-ventilated area.**

**DANGER CONTINUED ON NEXT PAGE...**

---

** DANGER**

- Do not operate gasoline vehicle in an enclosed area without proper ventilation. The engine produces carbon monoxide, which is an odorless, deadly poison.
- A Club Car vehicle will not provide protection from lightning, flying objects, or other storm-related hazards. If caught in a storm while driving a Club Car vehicle, exit the vehicle and seek shelter in accordance with applicable safety guidelines for your location.

** WARNING**

- Follow the procedures exactly as stated in this manual, and heed all DANGER, WARNING, and CAUTION statements in this manual as well as those on the vehicle and battery charger.
- Do not leave children unattended on vehicle.
- Prior to leaving the vehicle unattended or servicing the vehicle, set the park brake, place the Forward/Reverse handle in the NEUTRAL position, turn the key switch to the OFF position, and remove the key. Chock the wheels when servicing the vehicle.
- Improper use of the vehicle or failure to properly maintain it could result in decreased vehicle performance, severe personal injury, or death.
- Any modification or change to the vehicle that affects the stability or handling of the vehicle, or increases maximum vehicle speed beyond factory specifications, could result in severe personal injury or death.
- Check the vehicle for proper location of all vehicle safety and operation decals and make sure they are in place and are easy to read.
- For vehicles with cargo beds, remove all cargo before raising the bed or servicing the vehicle. If the vehicle is equipped with a prop rod, ensure that it is securely engaged while bed is raised. Do not close bed until all persons are clear of cargo bed area. Keep hands clear of all crush areas. Do not drop cargo bed; lower gently and keep entire body clear. Failure to heed this warning could result in severe personal injury or death.
- Only trained technicians should service or repair the vehicle or battery charger. Anyone doing even simple repairs or service should have knowledge and experience in electrical and mechanical repair. The appropriate instructions must be used when performing maintenance, service, or accessory installation.

**All electric vehicles:**

- Ensure battery connections are clean and properly tightened. See Battery Care on page 49.
- To avoid unintentionally starting the vehicle, disconnect the batteries as shown (Figure 2, Figure 3, Figure 4, Figure 5, or Figure 6).

**IQ System and IQ Plus vehicles:**

- Place Tow/Run switch in the TOW position before disconnecting or connecting the batteries. Failure to heed this warning could result in a battery explosion or severe personal injury.
- After disconnecting the batteries, wait 90 seconds for the controller capacitors to discharge.
- Use only 4-gauge (AWG) wires with low-resistance terminals to replace battery wires on IQ Plus models.

**WARNING CONTINUED ON NEXT PAGE...**

## **⚠ WARNING**

### PowerDrive System 48 vehicles:

- After disconnecting the batteries, discharge the controller capacitors as follows:
  - Turn the key switch to the ON position and place the Forward/Reverse handle in the REVERSE position.
  - Slowly press the accelerator pedal and keep it pressed until the reverse warning buzzer can no longer be heard. When the buzzer stops sounding, the controller capacitors are discharged.

### Gasoline vehicles:

- To avoid unintentionally starting the vehicle:
  - Disconnect battery cables, negative (–) cable first (Figure 1).
  - Disconnect the spark plug wire from the spark plug.
- Frame ground – Do not allow tools or other metal objects to contact frame when disconnecting battery cables or other electrical wiring. Do not allow a positive wire to touch the vehicle frame, engine, or any other metal component.

### All vehicles:

- Wear safety glasses or approved eye protection when servicing the vehicle or battery charger. Wear a full face shield and rubber gloves when working on or near batteries.
- Do not wear loose clothing or jewelry such as rings, watches, chains, etc., when servicing the vehicle or battery charger.
- Use insulated tools when working near batteries or electrical connections. Use extreme caution to avoid shorting of components or wiring.

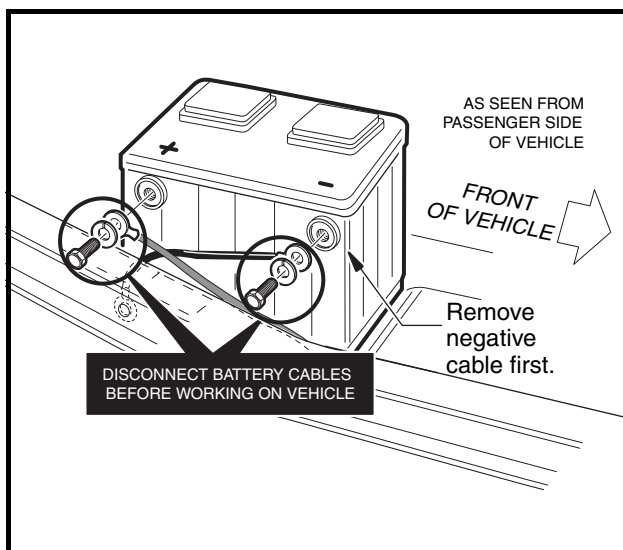

Figure 1 Gasoline Vehicle

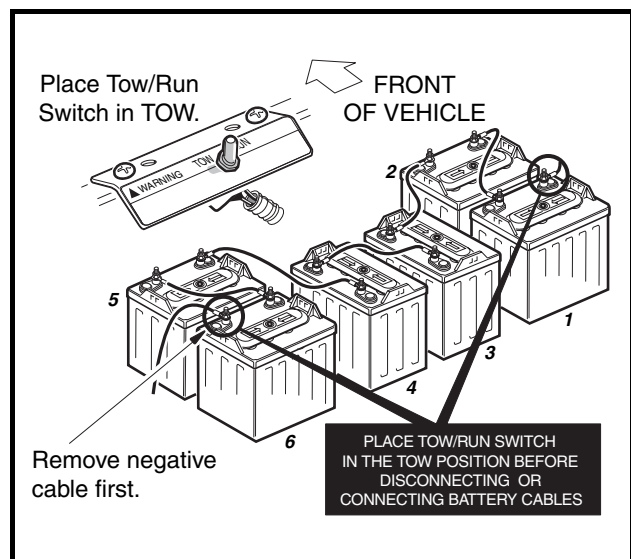

Figure 2 IQ System Vehicle – 8-Volt Battery Configuration

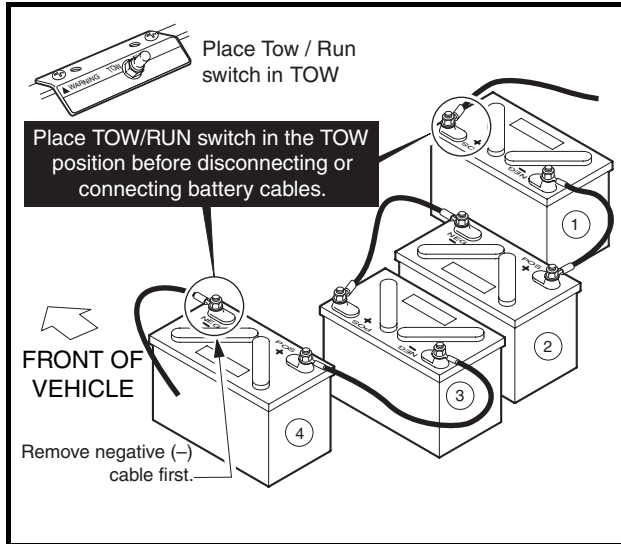

Figure 3 IQ System Vehicle – 12-Volt Battery Configuration

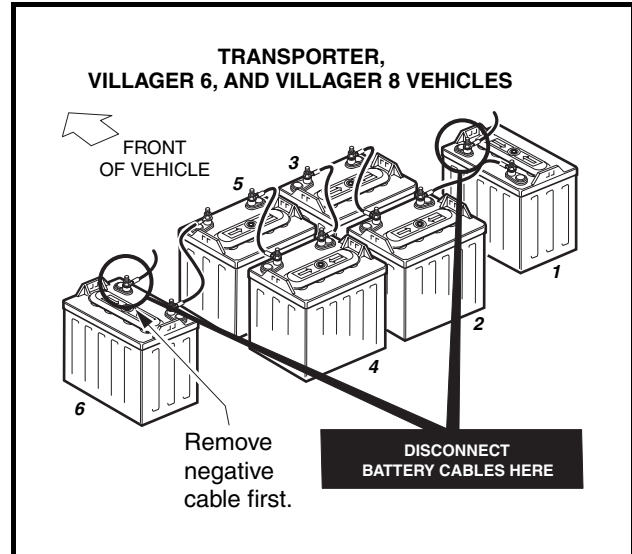

Figure 4 PowerDrive System 48 Electric Vehicle

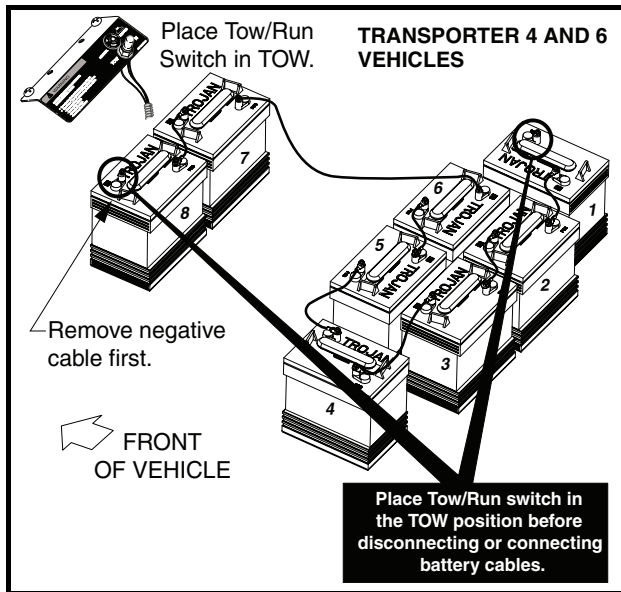

Figure 5 IQ Plus Electric Vehicle

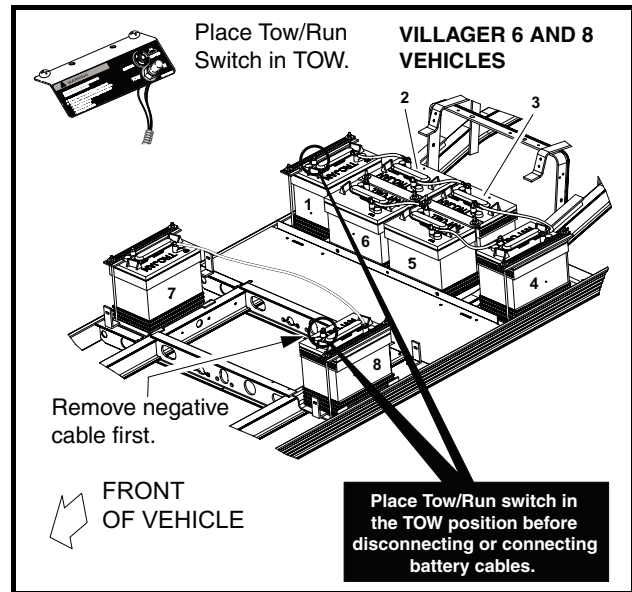

Figure 6 IQ Plus Electric Vehicle

## GENERAL INFORMATION

There are two Transportation models: the Villager and the TransPorter. The DS Villager 4 electric vehicle uses the IQ System electrical system; Villager 6, Villager 8, and Transporter electric vehicles use either the PowerDrive System 48 or the IQ Plus electrical system. Throughout this manual, important features unique to each model and electrical system are highlighted. We urge the owner/operator to read and understand this manual, and to pay special attention to the features specific to their vehicle(s).

---

## MODEL IDENTIFICATION

---

The serial number of the vehicle is printed on a bar code decal (1) mounted on the frame directly above the accelerator pedal (Example: FQ0601-123456) (**Figure 7**). There is also a second serial number decal mounted on the front body frame behind the center dash panel. The center dash panel must be removed to view this decal. **See following NOTE.**

**NOTE:** Have the vehicle serial number available when ordering parts or making inquiries.

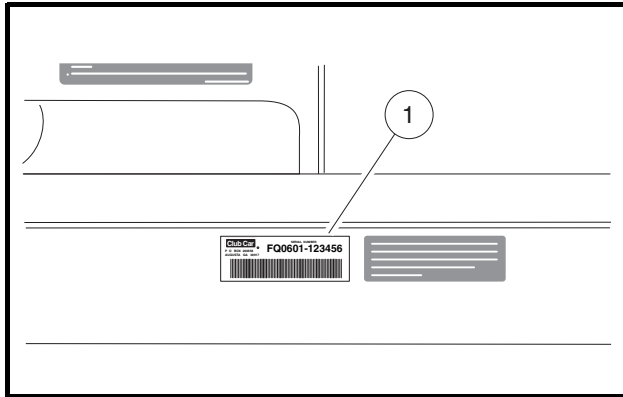

Figure 7 Serial Number

---

## CONTROLS AND INDICATORS

---

See General Warnings on page 19.

### **⚠ WARNING**

- Before allowing anyone to drive the vehicle, make sure the driver is familiar with all controls and operating procedures.
- Do not shift the Forward/Reverse handle or switch while the vehicle is moving. To avoid injury to passenger(s) or damage to the vehicle, always bring the vehicle to a full stop before shifting the handle or switch.
- Release the accelerator pedal and then press the brake pedal firmly until the vehicle stops. To avoid unintentionally starting or rolling the vehicle, set the park brake, place the Forward/Reverse handle or switch in the NEUTRAL, turn the key switch to the OFF position, and remove the key when leaving the vehicle.
- Gasoline vehicles only: Do not tamper with the governor. Doing so will void the warranty, as well as damage the engine and other components, and could result in property damage, personal injury, or death due to unsafe speeds.

### KEY SWITCH

Each vehicle is equipped with either a two-position key switch or a three-position key switch. Vehicles equipped with a two-position key switch are referred to as pedal-start and vehicles equipped with a three-position key switch are referred to as key-start. All electric Transportation vehicles are equipped with a two-position (pedal-start) key switch.

The key switch is mounted on the dash to the right of the steering column.

- **Pedal-start vehicle:** The key switch has two positions, OFF and ON, which are clearly labeled (**Figure 8**).
- **Key-start vehicle:** The key switch has three positions, OFF, ON, and START, which are clearly labeled (**Figure 9**). To start the vehicle, turn the key past the ON position to the START position and hold until the engine is running smoothly. Release the key and it will return to the ON position and the engine should idle. **See following NOTE.**

**NOTE:** The key can be removed only when the key switch is in the OFF position.

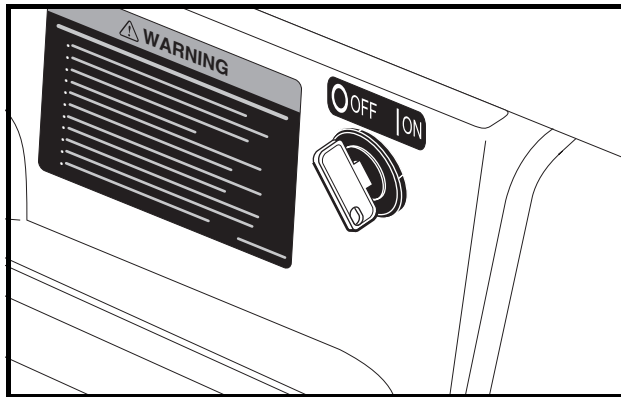

**Figure 8 Two Position Key Switch – Pedal-Start Vehicle**

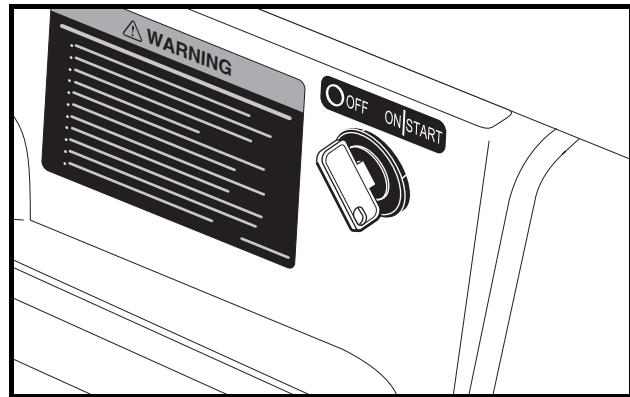

**Figure 9 Three Position Key Switch – Key-Start Vehicle**

## FORWARD/REVERSE CONTROL

### PowerDrive System 48 Electric and Gasoline Vehicles

The Forward/Reverse handle is located on the seat support panel (**Figure 10**). The handle has three distinct positions: **F** (FORWARD), **N** (NEUTRAL), and **R** (REVERSE). Rotate the handle towards the driver (FORWARD) to operate the vehicle in the forward direction, or towards the passenger (REVERSE) to operate the vehicle in the REVERSE position. Club Car vehicles operate at reduced speed in reverse. The reverse buzzer(s) will sound as a warning when the Forward/Reverse handle is in the REVERSE position.

- **Pedal-start vehicle:** When handle is in the straight up position (NEUTRAL), vehicle will not operate.
- **Key-start vehicle:** The engine will idle while in the NEUTRAL position. **See following NOTE.**

**NOTE: Key-start vehicle:** The engine will stop running if the accelerator is pressed while the Forward/Reverse handle is in the NEUTRAL position.

### IQ System and IQ Plus Electric Vehicles

The Forward/Reverse rocker switch is located in the same place as the Forward/Reverse handle on other models: on the seat support panel below and to the right of the driver's knee (**Figure 11**). The **F** (FORWARD) and **R** (REVERSE) positions are clearly marked. Push down the FORWARD side of the switch to operate the vehicle in the forward direction, or push down the REVERSE side of the switch to operate the vehicle in reverse. When the rocker switch is positioned in NEUTRAL, with neither side down, the vehicle will not operate if the accelerator pedal is pressed. The reverse buzzer will sound as a warning when the Forward/Reverse switch is in the REVERSE position.

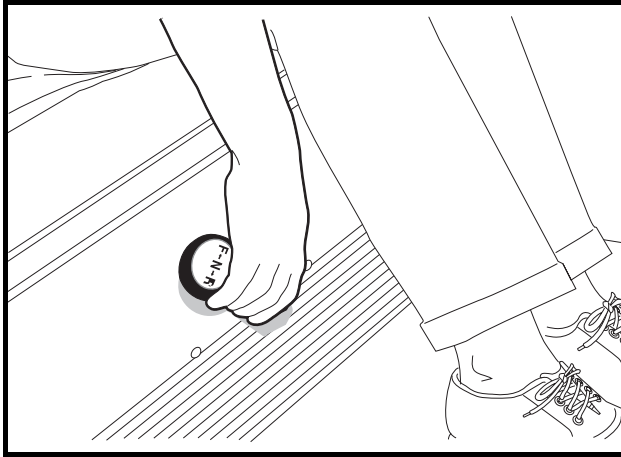

Figure 10 Forward/Reverse Handle

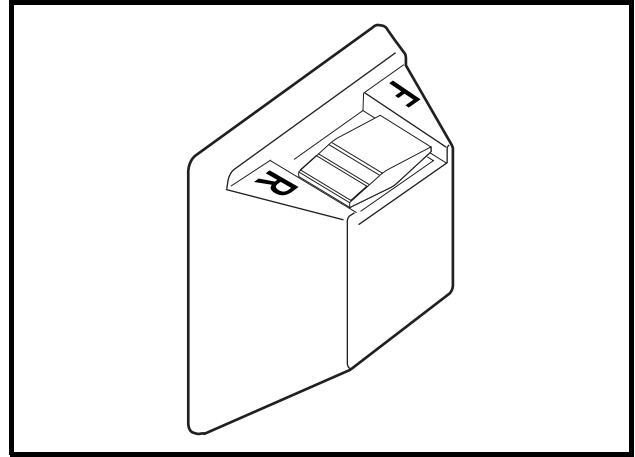

Figure 11 Forward/Reverse Rocker Switch

## ACCELERATOR PEDAL

The accelerator pedal is the pedal on the right, with the word GO molded into it (**Figure 12**). The operation of the accelerator pedal differs from that of an automobile.

- **Pedal-start vehicles:** When the key switch is in the ON position, and the Forward/Reverse handle is in either the FORWARD or REVERSE position, pressing the accelerator pedal will automatically release the park brake and start the vehicle moving in the direction selected (forward or reverse). As the accelerator pedal is pressed, speed will increase until full speed is reached. When the accelerator pedal is released, power will be cut off and the motor or engine will stop running.
- **Key-start vehicles:** The engine must first be running before shifting the Forward/Reverse handle and pressing the accelerator pedal. As the accelerator pedal is pressed, speed will increase until full speed is reached. When the accelerator pedal is released, it will return to the original position and the engine will idle.

## IQ System and IQ Plus Electric Vehicles

IQ System and IQ Plus vehicles use a special electrical system, which employs motor braking in some modes of operation. In those modes, the vehicle operates as follows:

- **Zero Speed Detect:** This prevents the vehicle from rolling away uncontrolled should the driver park on a slope and leave the vehicle without locking the park brake. The vehicle will roll at about 1 mph (1.6 km/h). If the zero speed detect function remains engaged for two seconds or more, a warning buzzer will sound to alert the driver that motor braking has been activated.

### **⚠ WARNING**

- **Zero speed detect will not limit vehicle speed to 1 mph (1.6 km/h) on very steep grades. Do not operate vehicle on slopes exceeding 20% grades.**
- **Pedal Down Motor Braking:** This feature helps to control vehicle downhill speed. Motor braking is activated when the vehicle reaches the programmed top speed and holds the vehicle at that speed. Motor braking is automatically disengaged when vehicle speed slows below the programmed top speed.

- **Pedal Up Motor Braking:**

**IQ System vehicles:** When vehicle speed is above 11 mph (17.7 km/h), releasing the accelerator pedal will activate motor braking, which slows the vehicle speed. Once vehicle speed slows to below approximately 11 mph (17.7 km/h), with the accelerator pedal still released, motor braking will be deactivated and the vehicle will coast freely. This feature is selectable. Contact your Club Car dealer/distributor to inquire about this selectable feature.

**IQ Plus vehicles:** Speed settings are programmable for IQ Plus vehicles. Motor braking is activated when the accelerator pedal is released at or above the programmed speed. When the vehicle slows to the programmed lower speed; motor braking will disengage. If no speed settings are programmed, motor braking will be activated at any time accelerator pedal is released, and it will only disengage when the vehicle comes to a stop. Contact your Club Car dealer/distributor to inquire about this programmable feature.

## BRAKE PEDAL

The brake pedal is the large pedal on the left with the word STOP molded into it (**Figure 12**). To slow or stop the vehicle, press the brake pedal with your foot (**Figure 13**).

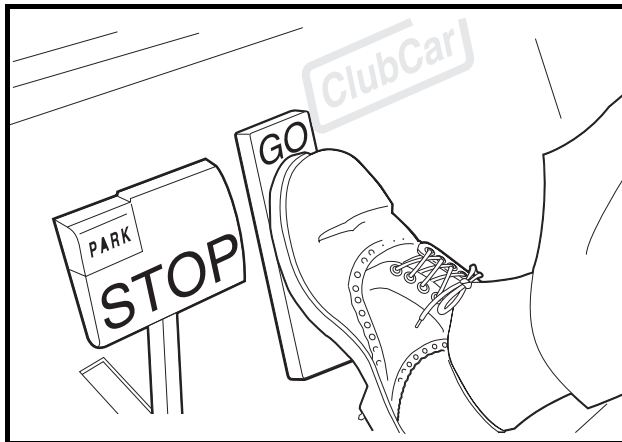

Figure 12 Accelerator and Brake Pedals



Figure 13 Brake Pedal

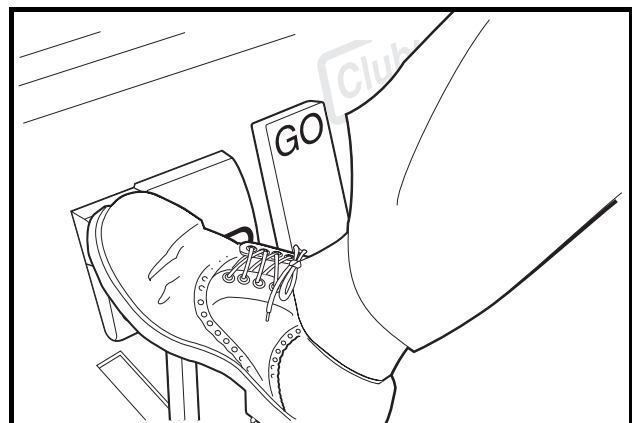

Figure 14 Park Brake Pedal

## PARK BRAKE PEDAL

The park brake pedal is the small raised portion in the upper left corner of the brake pedal. It has the word PARK molded into it and the words PARK BRAKE marked on top (**Figure 13**). To set the park brake, press the brake pedal firmly and tilt the park brake portion of the pedal forward (**Figure 14**). See following **WARNING**.

### **⚠ WARNING**

- The park brake will release automatically when either the accelerator or brake pedal is pressed. The park brake has multiple locking positions and should be firmly pressed and locked to prevent the vehicle from rolling.

## HEADLIGHT CONTROL

### Vehicles with Headlights

The headlight control is located on the front dash to the left of the and steering column. Pull the headlight control knob out to turn the headlights on and push the knob in to turn the headlights off.

**NOTE: Gasoline vehicles:** Using the headlights for extended periods of time without the engine running, or with the engine idling, will discharge the battery.

## BATTERY CONDITION INDICATOR

### Electric TransPorter, Villager 6, and Villager 8 Vehicles

The battery condition indicator features a 10-bar LED display that, when the vehicle is in operation, displays the level of battery capacity, measuring battery voltage over a period of time.

When batteries are fully charged, all indicator lights will be on. When battery voltage drops below 75% of full discharge, the last two indicator lights will flash alternately. Continued use of vehicle after indicator lights begin flashing without recharging could result in decreased vehicle performance.

**NOTE:** If the battery condition indicator moves rapidly (approximately 45 minutes) from full charge to empty, there may be a problem with the wiring or with a battery cell. If indicator display does not reset back to full after recharging, there may be a problem with the battery charger or with one of the batteries. In either case the vehicle should be checked by a Club Car dealer or a trained technician.

## BATTERY WARNING LIGHT

### Electric Vehicles Only

Electric vehicles feature a dash mounted warning light (above steering column) that, when the vehicle is in operation, indicates low battery voltage or, when the vehicle is being charged, indicates a charging problem. The battery warning light is controlled by the onboard computer.

When the vehicle is in operation, the warning light will illuminate and remain illuminated if:

- Batteries' voltage drops below 48 volts when there is no load on the batteries (the vehicle is stopped and there are no accessories on).
- Batteries have discharged to less than 25% of rated capacity.

If the warning light comes on when the vehicle is operating, there will be enough power remaining to drive the vehicle for approximately 30 minutes. However, the vehicle should be charged at the first opportunity. If the warning light comes on and the vehicle is unable to operate for 30 minutes, have your Club Car distributor/dealer check the vehicle for a possible battery or electrical system problem.

When the batteries receive an incomplete charge because 1) the DC power cord is disconnected, 2) AC power to the charger is interrupted, 3) automatic charger shut-off occurs after 16 hours of operation, 4) the charger malfunctions, or 5) the wrong charger is used, the warning light will indicate as follows:

- The warning light will not come on if the charge is 90% or more complete. The onboard computer will retain in memory the amount of charge needed to fully replenish the batteries and will complete the charge during the next charge cycle.
- When the charger is unplugged, the warning light will illuminate and remain illuminated for 10 seconds if the charge is less than 90% complete but the vehicle has enough power for approximately 30 minutes of operation. This will alert the operator that the vehicle may be used, but that it must be charged to completion as soon as possible.
- The warning light will repeatedly illuminate for 10 seconds, with 4 second intervals if the charger times out at 16 hours and the batteries are not sufficiently charged. **See the battery charger owner's manual.** This indicates an abnormal charge cycle. The charger and batteries should be checked by your Club Car distributor/dealer.
- The warning light will repeatedly illuminate for 10 seconds, with 4 second intervals during a charge cycle (DC plug is still connected) if AC power to the charger is interrupted. The light will go out when AC power is restored.

**LED Light:** In addition to the warning light, there is an infrared LED in the dash light assembly, which transmits an infrared signal from the onboard computer (OBC). This signal is received by the optional Communication Display Module, which provides information on the condition of the vehicle and batteries.

## TOW/RUN SWITCH

### IQ System and IQ Plus Electric Vehicles Only

#### **WARNING**

- **Place Tow/Run switch in the TOW position before disconnecting or connecting the batteries. Failure to heed this warning could result in a battery explosion or severe personal injury.**
- **When the Tow/Run switch is in the TOW position, all motor braking functions, including zero-speed detect, are disabled.**

IQ System and IQ Plus vehicles are equipped with a Tow/Run switch (1), located on the seat support panel under the seat (**Figure 15** or **Figure 16**). The switch must be in the RUN position in order to operate the vehicle. When the switch is in the TOW position, power to the vehicle electrical components is turned off and the vehicle will not operate. **See following NOTE.**

**NOTE:** *After placing the Tow/Run switch in the TOW position, allow 10 seconds to elapse before switching back to the RUN position.*

*After placing the Tow/Run switch in RUN position, allow 10 seconds to elapse before operating the vehicle.*

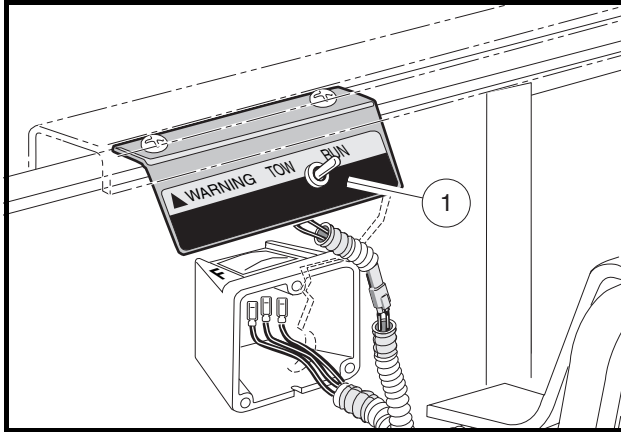

Figure 15 Tow/Run Switch – IQ System

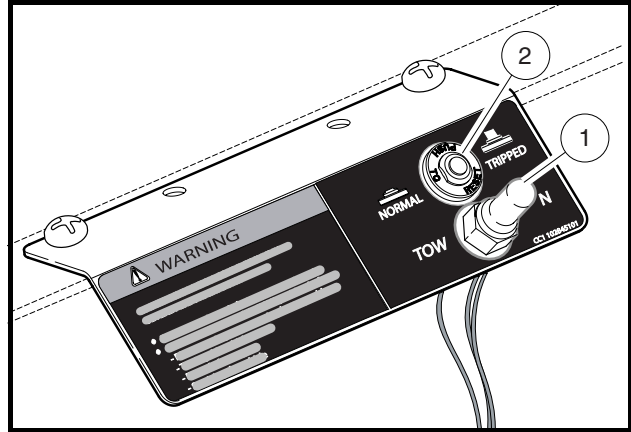

Figure 16 Tow/Run Switch – IQ Plus

The Tow/Run switch should be placed in the TOW position under the following conditions:

- **Before Towing the Vehicle:** Place the Tow/Run switch in the TOW position to disable all motor braking functions, thus preventing possible damage that could occur to the vehicle or electrical components if the vehicle is towed while the Zero-Speed Detect motor braking function is operating.
- **Before Disconnecting or Connecting Battery Cables:** Place the Tow/Run switch in the TOW position to turn off power to the vehicle electrical system, thus preventing severe arcing and possible battery explosion as the battery cables are disconnected.
- **For Long Term Storage:** Place the Tow/Run switch in the TOW position to turn off power to the vehicle electrical system, thus preventing vehicle electrical components from discharging the batteries.

## CIRCUIT BREAKER

### IQ Plus Electric Vehicles Only

IQ Plus vehicles are equipped with a circuit breaker (2), located next to the Tow/Run switch (**Figure 16**). If the circuit breaker has been tripped, a series of rapid beeps will sound and vehicle speed will slow to approximately one-half of its top programmed speed. In the event of a tripped circuit breaker, bring the vehicle to a complete stop, remove seat, and push the breaker to reset. If the circuit breaker trips again when vehicle operation is resumed, contact a local Club Car distributor/dealer.

## NEUTRAL LOCKOUT

### Gasoline Vehicles Only

For the convenience of the trained technician, there is a neutral lockout cam (yellow knob) located on the back of the Forward/Reverse shifter, inside the engine compartment. If the neutral lockout cam is pulled out approximately 3/8 inch (10 mm) and then rotated one-half turn until it snaps into place, the cam will be in the MAINTENANCE position (**Figure 17**).

- **Pedal-start vehicle:** When the cam is in the MAINTENANCE position, it will allow the mechanic to run the engine in neutral for certain maintenance procedures. With the cam in this position, the vehicle will not operate if the Forward/Reverse handle is placed in either the FORWARD or REVERSE position.
- **Key-start vehicle:** When the cam is in the MAINTENANCE position, it will allow the mechanic to run the vehicle in forward, reverse, or neutral for certain maintenance and/or repair functions. However, if the Forward/Reverse handle is in either FORWARD or REVERSE and the accelerator is pressed, the engine will stop running.

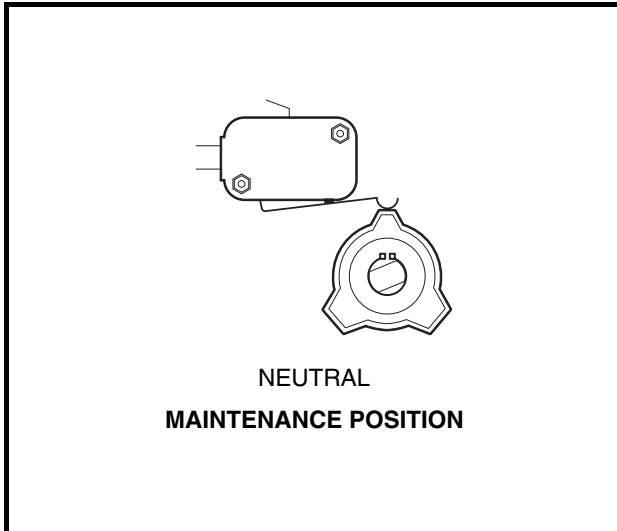

Figure 17 Neutral Lockout – Maintenance

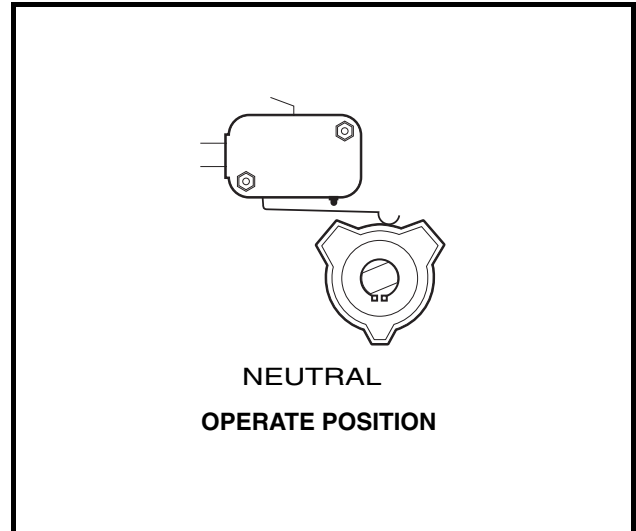

Figure 18 Neutral Lockout – Operate

To put the cam back into the OPERATE position, pull the cam out approximately 3/8 inch (10 mm) and rotate it one-half turn until it snaps into place (**Figure 18**). See following **WARNING** and **NOTE**.

### **⚠ WARNING**

- **With the cam in the MAINTENANCE position and the engine running, the vehicle may move suddenly if the Forward/Reverse handle is shifted or accidentally bumped. To prevent this, chock the front and rear wheels and firmly set the park brake before servicing or leaving the vehicle.**

**NOTE: Pedal-start vehicle:** Be sure to return the cam to the OPERATE position after servicing the vehicle, or it will not run with the Forward/Reverse handle in either the FORWARD or REVERSE position.

**Key-start vehicle:** The cam must be returned to the OPERATE position after servicing is complete, or the engine will stop running when the accelerator pedal is pressed, and the Forward/Reverse handle is in the FORWARD or REVERSE position.

## **CHOKER**

### **Gasoline Vehicles Only**

The choke is located on the seat support panel (**Figure 19** and **Figure 20**). If the vehicle is hard to start in cool or cold temperatures, activate the choke:

- **DS Villager 4 vehicle:** Press the choke cover. Hold choke cover in during start-up and release it after the engine starts and runs smoothly.
- **TransPorter, Villager 6 and Villager 8 vehicles:** Pull out the choke cable. Hold choke cable out during start-up and release it after the engine starts and runs smoothly.

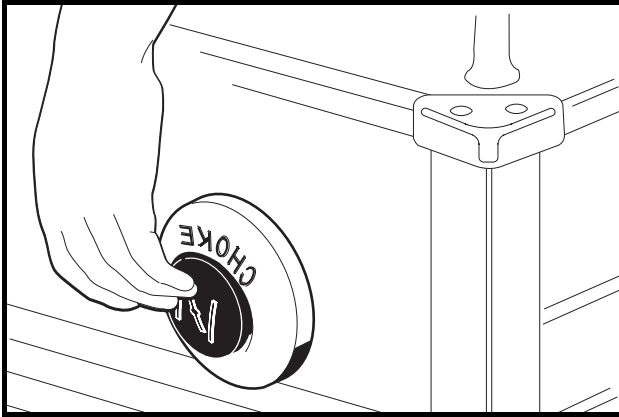

Figure 19 Button Choke

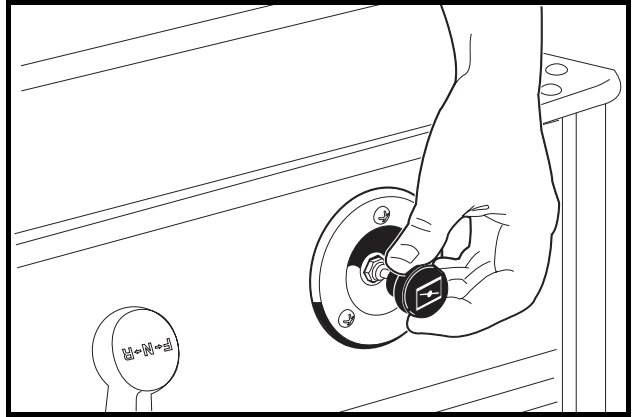

Figure 20 Cable Choke

## LOW OIL WARNING LIGHT

### Gasoline Vehicles Only

The vehicle is equipped with a low oil warning light (1), located on the dash panel just above the steering column (**Figure 21**). If the warning light comes on, oil should be checked and added to the engine as necessary before continuing to use the vehicle. The vehicle should never be driven when the low oil warning light remains on. If the warning light goes on and off, the vehicle may be driven, but oil should be added at the first opportunity. If the oil level is correct and the warning light stays on, have a trained technician check the vehicle.

### **CAUTION**

- Failure to add oil immediately when the low oil warning light stays on may result in permanent engine damage.

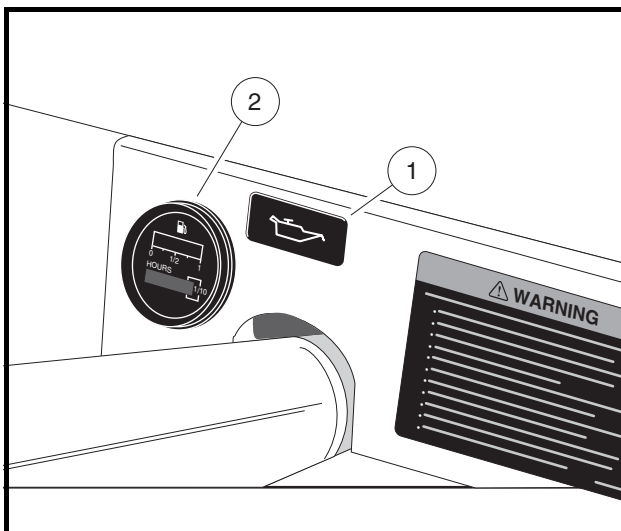

Figure 21 Fuel Gauge/Hour Meter and Low Oil Warning Light

---

## FUEL GAUGE/HOUR METER

### Gasoline Vehicles Only

The gasoline-powered Club Car vehicle is equipped with a fuel gauge/hour meter (2), located on the dash panel (**Figure 21**). The fuel gauge allows the operator to monitor the fuel level in the vehicle. The hour meter should be used by a trained technician to track vehicle usage and to help determine when periodic service is required. **See Periodic Service Schedules on page 43.**

---

## PRE-OPERATION AND DAILY SAFETY CHECKLIST

Each Club Car vehicle has been thoroughly inspected and adjusted at the factory; however, upon receiving your new vehicle(s), you should become familiar with its controls, indicators, and operation. Carefully inspect each vehicle to ensure that it is in proper working condition before accepting delivery.

Use the following checklist as a guide to inspect the vehicle. This checklist should be used daily to ensure that the vehicle is in proper working condition and in conjunction with the Periodic Service Schedule on page 44. Any problems should be corrected by a Club Car distributor/dealer or a trained technician.

- **General:** All the parts should be in place and properly installed. Be sure that all nuts, bolts, and screws are tight. On gasoline vehicles, check all hose clamps for tight fit as well as the starter belt for tightness.
- **Safety and information decals:** Check to ensure that all safety and information decals are in place. **See pages 4 through 17.**
- **Tires:** Check for proper tire pressure. Visually inspect for wear, damage, and proper inflation on a daily basis. **See Vehicle Specifications – Electric Vehicles on page 59.**
- **Battery(ies):** Check electrolyte to ensure that it is at its proper level (**Figure 27, Page 49 or Figure 32, Page 55**). Check battery posts. Wires should be tight and free of corrosion. On electric vehicles, charge batteries fully before first use of vehicle.
- **Charger cord, plug, and receptacle (electric vehicles):** Visually inspect for cracks, loose connections, and frayed wiring. **See Plug and Receptacle on page 53.**
- **Engine (gasoline vehicles):** Check for proper engine oil level. **See Engine Oil – Gasoline Vehicles on page 55.**
- **Fuel (gasoline vehicles):** Check fuel level. **See Fueling Instructions – Gasoline Vehicles on page 56.** Check fuel tank, lines, cap, pump, fuel filters, and carburetor for fuel leakage on a daily basis.
- **Exhaust system (gasoline vehicles):** Check for leaks.

### **WARNING**

- **Be sure the plastic has been removed from the seat bottom before operating the vehicle. Failure to do so may result in fire, property damage, personal injury, or death.**

---

## PERFORMANCE INSPECTION

After you have familiarized yourself with the vehicle controls and have read and understood the driving instructions, take the vehicle for a test drive.

Use the following checklist as a guide to inspect the vehicle and check daily for proper operation. Any problems should be corrected by a Club Car distributor/dealer or a trained technician.

## All Vehicles

- **Forward/Reverse control:** Check for proper operation. **See Controls and Indicators on page 23.**
- **Brakes:** Be sure the brakes function properly. When brake pedal is fully pressed under moderate pressure, it should not go more than halfway to the floor, and vehicle should come to a smooth, straight stop. If the brake pedal goes more than halfway to the floor or if the vehicle swerves or fails to stop, have the brake system checked and adjusted as required. Brake adjustment must be maintained so that the brake pedal cannot be pressed to the floor under any circumstance.
- **Park brake:** When latched, the park brake should lock the wheels and hold the vehicle stationary (on an incline of 20% or less). It should release when either the accelerator or brake pedal is pressed.
- **Reverse buzzer:** The reverse buzzer should sound as a warning when the Forward/Reverse handle or switch is in the REVERSE position.
- **Steering:** The vehicle should be easy to steer and should not have any play in the steering wheel.
- **General:** Listen for any unusual noises such as squeaks or rattles. Check the vehicle ride and performance. Have a Club Car distributor/dealer or a trained technician investigate anything unusual.

## Electric Vehicles

- **Accelerator:** As the accelerator pedal is pressed, the motor should start and the vehicle should accelerate smoothly to full speed. When the pedal is released it should return to the original position and the motor should rotate freely. The vehicle will run at a reduced speed when in the REVERSE position.  
**IQ System and IQ Plus vehicles only:** When the pedal is released it should return to the original position and the motor should rotate freely or go into motor braking mode. **See Pedal Up Motor Braking below.**

## IQ System and IQ Plus Electric Vehicles

- **Zero Speed Detect:** With the vehicle parked on level ground and the park brake disengaged, place the Tow/Run switch in the RUN position and attempt to push the vehicle. Motor braking should engage and cause resistance to rolling (moving at no more than 1 to 3 mph) (1.5 to 4.8 km/h) with the Forward/Reverse switch in any position. When zero speed detect motor braking is engaged, the reverse buzzer should emit a distinct pattern of beeps. **See following WARNING.**

### **WARNING**

- **Zero-speed detect will not limit vehicle speed to 1 mph (1.6 km/h) on very steep grades. Do not operate vehicle on slopes exceeding 20% grades.**
- **Pedal Up Motor Braking:** Accelerate the vehicle to full speed and then release the accelerator pedal. Motor braking should quickly and smoothly slow the vehicle. Motor braking will disengage when vehicle slows to 11 mph (17.7 km/h) for IQ System vehicles and at the programmed speed for IQ Plus vehicles. This feature is selectable for IQ System vehicles and programmable for IQ Plus vehicles. Contact your local Club Car dealer/distributor to inquire about this adjustable feature.
- **Pedal Down Motor Braking:** Accelerate down an incline with the accelerator pedal pressed. When the vehicle reaches maximum designed speed, motor braking should engage and limit the vehicle to its maximum designed speed. On very steep grades, the vehicle may slightly exceed its maximum designed speed, requiring use of the brake pedal.

## Gasoline Vehicles

- **Accelerator for pedal-start vehicles:** With the key switch in the ON position and the Forward/Reverse handle in the FORWARD position, as the accelerator pedal is pressed, the engine should start and the vehicle should accelerate smoothly to full speed. When the pedal is released it should return to the original position and the engine should stop. All Club Car vehicles operate at reduced speed in reverse.
- **Accelerator for key-start vehicles:** After starting the engine with the key switch and placing the Forward/Reverse handle in the FORWARD position, the vehicle should accelerate smoothly to full speed as the accelerator pedal is pressed. When the accelerator pedal is released it should return to the original position and the engine should idle.
- **Governor:** Check maximum speed of the vehicle. All DS Villager 4 vehicles should run at 12-15 mph (19-24 km/h) on a level surface. The TransPorter, Villager 6, and Villager 8 gasoline-powered vehicles should run at 14-16 mph (23-26 km/h) on a level surface.

## DRIVING INSTRUCTIONS

### **WARNING**

- Only licensed drivers should be allowed to drive the vehicle.
- Before allowing anyone to drive the vehicle, make sure the driver is familiar with all controls and operating procedures.
- No more than two people per seat at one time.
- Do not allow riders in the cargo bed.
- The vehicle is not specially equipped for handicapped persons:
  - Make sure all persons can properly operate the vehicle prior to allowing them to drive the vehicle.
  - Make sure all passengers are capable of securing themselves in a vehicle before allowing them to ride in one.
- For night use, vehicle must be equipped with headlights, taillights, and reflectors.
- Stop vehicle before shifting Forward/Reverse handle or switch. Failure to do so may result in injury to inattentive passengers and (or) damage to the vehicle.
- To help avoid being struck, do not stand in front of or behind the vehicle.
- Do not leave children unattended on vehicle.
- Operate the vehicle from the driver seat only.
- To help prevent falls from the vehicle, remain seated and hold on to hand holds or handrails at all times. Driver should keep both hands on the steering wheel when the vehicle is in motion.
- To help prevent the possibility of serious injury, keep entire body inside vehicle.
- To help prevent vehicle from overturning, drive slowly in turns.
- To help prevent vehicle from overturning, drive slowly straight up and down slopes. Avoid driving the vehicle on slopes exceeding 20% incline.
- Avoid stopping a loaded vehicle on a hill. If a loaded vehicle must be stopped on a hill, avoid sudden starts or rolling backwards and stopping suddenly. Failure to heed this warning could result in the vehicle overturning.

WARNING CONTINUED ON NEXT PAGE...

---

## **▲ WARNING**

- To help avoid possible injury to inattentive passengers and (or) damage to the vehicle, avoid sudden starts, sudden stops, and abrupt turns.
- To help avoid the possibility of losing control of or overturning the vehicle, reduce speed for adverse driving conditions such as wet grass or rough terrain.
- Do not use the vehicle on public roads. It is neither designed nor intended for street use and should not be licensed for use on public roads.
- The vehicle should be driven in only specified areas by trained operators.
- Do not drive while under the influence of alcohol, drugs, or medications.
- Use brakes to reduce speed when coasting downhill.

No one should drive the vehicle without first being instructed in the proper operation and use of the vehicle's controls. An experienced operator should accompany each first-time driver on a test drive before allowing him/her to operate the vehicle alone.

To ensure safe operation of the vehicle, follow all procedures exactly as written. Read and understand all instructions prior to driving the vehicle.

## **STARTING THE VEHICLE**

1. Read and understand controls. Read safety warnings located on dash and (or) above pedals.
2. Make sure load is secure.
3. Make sure everyone is seated and holding onto hand holds or handrails. Driver should have both hands on the steering wheel.
4. Make sure wheels are turned in desired direction and that nothing is obstructing vehicle's path.
5. Start the vehicle:

### **Electric and pedal-start gasoline vehicles:**

- 5.1. Turn the key to the ON position.
- 5.2. Select direction by placing the Forward/Reverse handle in the desired position (F = forward or R = reverse). A buzzer will sound as a warning when the Forward/Reverse handle or switch is in the REVERSE position.
- 5.3. Slowly press the accelerator pedal. The park brake will release automatically and the vehicle will start to move. As the accelerator pedal is pressed, speed will increase until full speed is reached. **See following WARNING and NOTE.**

### **Key-start gasoline vehicles:**

- 5.4. Make sure the Forward/Reverse handle is in the NEUTRAL position.
- 5.5. Press and hold brake pedal.
- 5.6. Turn the key all the way to the START position and release after the engine has started. The engine will idle with the Forward/Reverse handle in the NEUTRAL position.
- 5.7. Keeping brake engaged, place the Forward/Reverse handle in desired position (F = forward or R = reverse). A buzzer will sound as a warning when the vehicle is in the REVERSE position.
- 5.8. Release brake pedal and slowly press accelerator pedal. The park brake will release automatically and the vehicle will start to move. As the accelerator pedal is pressed, speed will increase until full speed is reached. **See following WARNING and NOTE.**

** WARNING**

- Operator must control speed when going downhill.

**IQ System and IQ Plus vehicles only:**

- Pedal down or pedal up motor braking may be used to help control speed when going downhill; however, steep terrain or other conditions may require that pedal braking be used in conjunction with motor braking.

**Gasoline vehicles only:**

- Do not shift the vehicle out of FORWARD while going downhill. If you do you will not be able to shift into REVERSE or back into FORWARD until stopped.
- Press the brake pedal as necessary and partially press the accelerator when descending a hill. With the accelerator pedal partially pressed, the governor will cause the engine to assist the brakes in controlling downhill speed.

**NOTE: Pedal-start vehicle:** If the vehicle is shifted into the NEUTRAL position, power will be cut off and the engine will stop running.

**Key-start vehicle:** If accelerator pedal is pressed while the Forward/Reverse handle is in the NEUTRAL position, or if Forward/Reverse handle is shifted from the FORWARD to REVERSE position while the accelerator pedal is pressed, power will be cut off and the engine will stop running. To keep engine running, the accelerator pedal must be released completely before shifting the vehicle.

**STOPPING THE VEHICLE**** WARNING**

- Driving through water may affect the brakes. After driving through water, check effectiveness of the brakes by gently pressing the brake pedal. If the vehicle does not slow down at the normal rate, continue to press the brake pedal until the brakes dry out and normal performance returns.

** CAUTION**

- When stopped on a hill, use the brake pedal to hold your position. Do not use the accelerator pedal.

To stop the vehicle, release the accelerator pedal and press the brake pedal until the vehicle comes to a complete stop.

**PARKING AND LEAVING THE VEHICLE**

1. After coming to a complete stop, firmly press the park brake pedal until it locks. This will prevent the vehicle from rolling.
2. Turn the key switch to the OFF position and place the Forward/Reverse handle or switch in the NEUTRAL position. Remove the key when the vehicle is not in use.
  - **IQ System and IQ Plus vehicles only:** When the Tow/Run switch is in the RUN position (with the Forward/Reverse switch or key switch in any position), the zero speed detect function will prevent the vehicle from rolling at more than 1 to 3 mph (1.5 to 4.8 km/h) unless the accelerator is pressed. This prevents the possibility of a parked vehicle (with the park brake disengaged) rolling away too fast to be overtaken on foot.
  - **Gasoline vehicles only:** Turn the fuel shut-off valve to the closed (OFF) position when the vehicle is not in use.

## LOADING AND UNLOADING

### **⚠ WARNING**

- Firmly engage the park brake before loading the vehicle.
- Do not allow riders in the cargo bed.
- Reduce vehicle load and speed when driving up or down slopes or on uneven terrain.
- Do not exceed the rated capacity of the vehicle. Rated capacity is for level surfaces only.
- Overloading can affect vehicle handling or cause component failure, resulting in loss of control of vehicle and possible severe personal injury or death.
- Reduce speed and avoid sudden stops when backing up. Failure to do so may cause the vehicle to overturn or flip over backwards.
- Do not load the tailgate. The tailgate should be in the upright position and latched securely while the vehicle is in motion.
- To help avoid shifting the vehicle load and possibly overturning the vehicle, avoid sudden starts, sudden stops, and abrupt turns.
- The cargo's center of gravity may affect the handling, steering, and braking of the vehicle. When the vehicle is loaded, reduce speed and drive slowly in turns.
- To help prevent cargo from shifting and possibly injuring a passenger or affecting the vehicle's handling, make sure cargo is well secured.
- Avoid top-heavy loads. The center of gravity of a load should never exceed 15 inches (38 cm) above the bottom of the cargo bed.
- Unload cargo bed before raising vehicle with hoist, jack, or other lifting device.

Center and secure cargo as far forward as possible in the cargo bed. Do not overload the vehicle. **See the following chart for vehicle capacities.**

	DS Villager 4	Villager 6 and Villager 8	TransPorter
<b>Maximum payload capacity</b> (Cargo bed load)	n/a	n/a	300 lb. (136 kg) (four-passenger only)
<b>Maximum vehicle capacity</b> (Cargo bed load plus passengers)	800 lb. (363 kg)	1500 lb. (680 kg)	1500 lb. (680 kg)

Maximum payload capacity must be reduced accordingly when any option or accessory is installed on the vehicle. **See following NOTE.**

**NOTE:** A standard TransPorter vehicle with a cab accessory weighing 235 lb. (107 kg) must reduce its maximum payload capacity by 235 lb. (107 kg) to 65 lb. (31 kg).

---

## TRANSPORTING ON A TRAILER

---

### WARNING

- Do not allow riders in the trailer being towed.
- Avoid sudden starts, sudden stops, and tight turns when towing.
- Avoid stopping on a hill when towing. If you must stop on a hill, avoid sudden starts or rolling backwards and stopping suddenly. Failure to heed this warning could cause the vehicle to overturn, possibly resulting in severe personal injury
- Reduce normal driving speed when towing a Club Car vehicle on a trailer.
- For use on public roads, the trailer must meet all federal, state, and local requirements such as taillights, brake lights, etc.
- Do not tow a Club Car vehicle behind a passenger vehicle or truck on a public road unless it is on an approved trailer.
- The vehicle to be towed should be tied securely to the trailer, with the Forward/Reverse handle or switch in the NEUTRAL position, the key switch in the OFF position, and the park brake firmly pressed and locked.
- Because of the added length of the trailer, use caution when making turns.
- Do not transport the vehicle on a trailer with a load in the vehicle cargo bed.
- Remove the windshield and secure the seat bottom before transporting on a trailer.
- Gasoline vehicles only: Turn the fuel shut-off valve to the closed (OFF) position (Figure 22, Page 41).

If the vehicle must be transported over long distances or on public highways, it should be transported on an approved trailer that has the following approved load rating per vehicle being transported:

DS Villager 4	800 lb. (363 kg)
Villager 6	1600 lb. (727 kg)
Villager 8	2000 lb. (909 kg)
TransPorter	2000 lb. (909 kg)

**NOTE:** A two-car trailer should be rated at 2 x 1600 lb. = 3200 lb. (2 x 727 kg = 1454 kg) for Villager 6, or 2 x 2000 lb. = 4000 lb. (2 x 909 kg = 1818 kg) for Villager 8 or TransPorter vehicles.

## STORAGE – ELECTRIC VEHICLES

---

See General Warnings on page 19.

### WARNING

- Turn the key switch to the OFF position, remove the key, and leave the Forward/Reverse handle or switch in the NEUTRAL position during storage. This is to prevent unintentionally starting the vehicle or a fire hazard. IQ System and IQ Plus vehicles only: Place Tow/Run switch in TOW position.
- Do not attempt to charge frozen batteries or batteries with bulged cases. Discard the battery. Frozen batteries can explode.

## **⚠ CAUTION**

- Batteries in a low state of charge will freeze at low temperatures.
- To avoid exposing electrical components to moisture and subsequent damage, do not use any type of pressure washing or steam cleaning equipment to wash the vehicle.

## **PREPARING THE ELECTRIC VEHICLE FOR EXTENDED STORAGE**

1. Unload the vehicle so that tires are supporting only the weight of the vehicle.
2. Fully charge batteries. **See Charging Batteries on page 52.**
3. Batteries should be clean and free of corrosion. Wash tops and terminals of batteries with a solution of baking soda and water (1 cup (237 mL) baking soda per 1 gallon (3.8 L) of water). Rinse solution off batteries. Do not allow this solution to enter the batteries. Be sure terminals are tight. Let the terminals dry and then coat them with Battery Terminal Protector Spray (CCI P/N 1014305).
4. Store vehicle in a cool, dry place. This will minimize battery self-discharge.
5. Adjust tires to recommended tire pressure. **See Vehicle Specifications – Electric Vehicles on page 59.**
6. Perform semiannual periodic lubrication. **See Periodic Lubrication Schedules on page 46.**
7. Thoroughly clean front body, rear body, seats, cargo bed, battery compartment, and underside of vehicle.
8. Do not engage the park brake. Chock the wheels to prevent the vehicle from rolling.
9. Keep batteries fully charged during storage.
  - Leave battery chargers plugged in during storage. The onboard computer will automatically activate the charger when necessary. If charger cannot remain plugged in, or AC power will not be available during extended storage, disconnect the batteries for storage (**Figure 2, Figure 3, Figure 4, Figure 5, or Figure 6**).

## **CAUTION**

- Be sure to check the vehicle and charger monthly to ensure the charger is operating correctly during storage.

## **RETURNING THE STORED ELECTRIC VEHICLE TO SERVICE**

1. If necessary, connect batteries and tighten terminals to 110 in-lb (12.4 N·m).
2. Fully charge batteries.
3. Adjust tires to recommended tire pressure. **See Vehicle Specifications – Electric Vehicles on page 59.**
4. Perform the Pre-Operation and Daily Safety Checklist on page 32.

---

## STORAGE – GASOLINE VEHICLES

---

See General Warnings on page 19.

### **DANGER**

- Do not attempt to drain gasoline when the engine is hot or while it is running.
- Be sure to clean up any spilled gasoline before operating the vehicle.
- Store gasoline in an approved gasoline container only. Store in a well-ventilated area away from sparks, open flames, heaters, or heat sources.
- Keep gasoline out of the reach of children.
- Do not siphon gasoline from the vehicle.

### **WARNING**

- Turn the key switch to the OFF position, remove the key, and leave the Forward/Reverse handle in the NEUTRAL position during storage. This is to prevent unintentionally starting the vehicle or a fire hazard.
- Turn the fuel shut-off valve to the closed (OFF) position (Figure 22, Page 41).
- Do not attempt to charge frozen batteries or batteries with bulged cases. Discard the battery. Frozen batteries can explode.

### **CAUTION**

- Batteries in a low state of charge will freeze at low temperatures.

## PREPARING THE GASOLINE VEHICLE FOR EXTENDED STORAGE

1. Unload the vehicle so that tires are supporting only the weight of the vehicle.
2. Store vehicle in a cool, dry place. This will minimize battery self-discharge. If the battery appears to be weak, have it charged by a trained technician. Use an automotive-type 12-volt battery charger rated at 10 amps or less.
3. Drain carburetor and seal the fuel tank.
  - 3.1. Place the Forward/Reverse handle in the NEUTRAL position and the neutral lockout cam in the MAINTENANCE position. Turn the fuel shut-off valve to the closed (OFF) position (**Figure 22**) and run the engine until fuel remaining in the carburetor and fuel lines is depleted and the engine stalls. Return the neutral lockout cam to the OPERATE position.

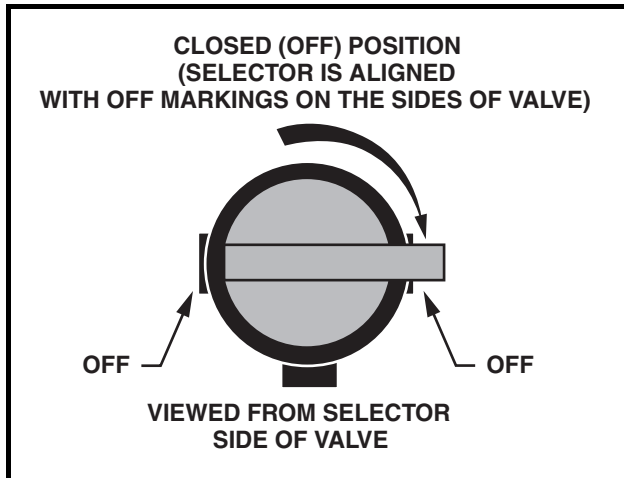

**Figure 22 Fuel Shut-off Valve – Closed Position**

- 3.2. Loosen, but do not remove, the carburetor drain screw and drain fuel remaining in bowl into a small, clean container, then pour the fuel from the container into vehicle fuel tank. Tighten the carburetor drain screw.
- 3.3. Fill fuel tank to about 1 inch (2.5 cm) from top of fuel tank and, following manufacturer's directions, add a commercially available fuel stabilizer (such as Sta-Bil®).
- 3.4. Disconnect fuel vent line from fuel tank vent nipple.
- 3.5. Plug the fuel tank vent nipple so that it is air tight. We recommend using a slip-on vinyl cap.
4. Disconnect the battery cables, negative (–) cable first.
5. Batteries should be clean and free of corrosion. Wash tops and terminals of batteries with a solution of baking soda and water (1 cup (237 mL) baking soda per 1 gallon (3.8 L) of water). Rinse solution off batteries. Do not allow this solution to enter the batteries. Be sure terminals are tight. Let the terminals dry and then coat them with Battery Terminal Protector Spray (CCI P/N 1014305).
6. To protect the engine, remove spark plug and pour 1/2 ounce (14.2 mL) of SAE 10 weight oil into the engine through the spark plug hole. Rotate engine crankshaft by hand several times and then install the spark plug.
7. Adjust tires to recommended tire pressure. **See Vehicle Specifications – Electric Vehicles on page 59.**
8. Perform semiannual periodic lubrication. **See Periodic Lubrication Schedules on page 46.**
9. Thoroughly clean front body, rear body, seats, cargo bed, engine compartment, and underside of vehicle.
10. Do not engage the park brake. Chock the wheels to prevent the vehicle from rolling.

## RETURNING THE STORED GASOLINE VEHICLE TO SERVICE

1. Restore fuel system to operation.
  - 1.1. Remove plug from the fuel tank vent (**Figure 35, Page 57**).
  - 1.2. Connect vent tube to fuel tank vent.
2. Connect battery cables, positive (+) cable first, and tighten terminals to 12 ft-lb (16 N·m).
3. Completely open the fuel shut-off valve (**Figure 23**). Make sure the valve is fully open. A partially closed fuel shut-off valve (**Figure 24**) combined with the use of the choke can result in a fouled spark plug and engine failure.
4. **Pedal-start vehicles:** Place the Forward/Reverse handle in the NEUTRAL position and the neutral lock-out cam in the MAINTENANCE position. Crank the engine until fuel is pumped into the carburetor and fuel lines and the engine starts. Turn the engine off and return the neutral lockout cam to the OPERATE position. **See following NOTE.**

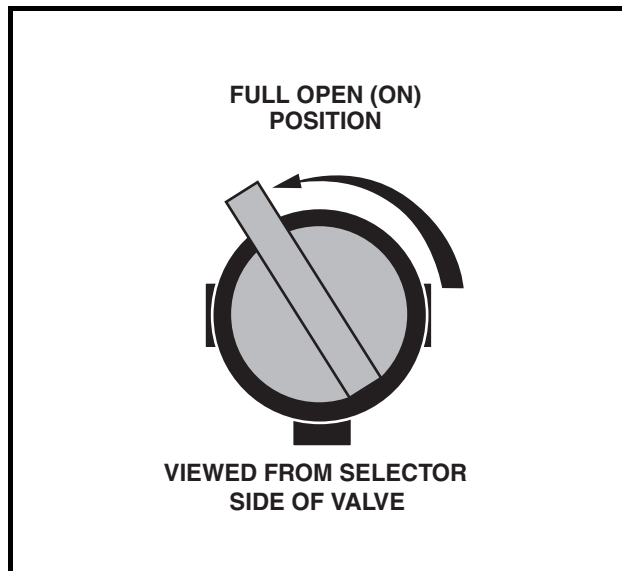

Figure 23 Fuel Shut-off Valve – Open Position

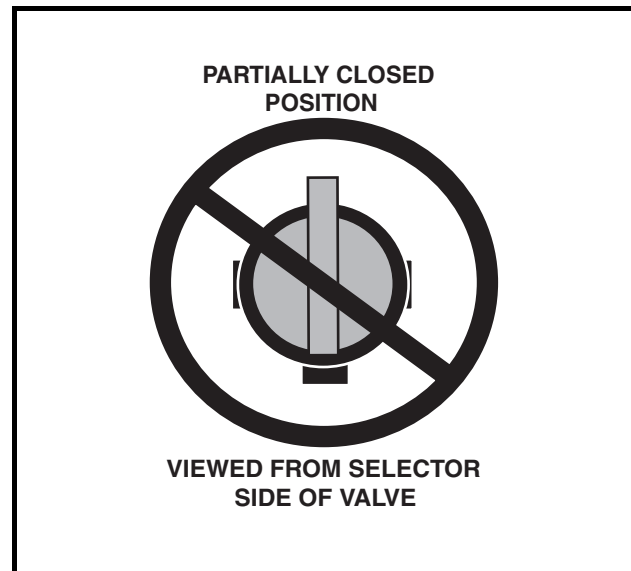

Figure 24 Fuel Shut-off Valve – Partially Closed Position

5. **Key-start vehicles:** Place the Forward/Reverse handle in the NEUTRAL position. Crank the engine until fuel is pumped into the carburetor and fuel lines and the engine starts. Turn the engine off. **See following NOTE.**

**NOTE:** Due to the oil added to the engine in preparation for storage, engine may smoke excessively for a short time when it is run for the first time after storage.

6. Adjust tires to recommended tire pressure. **See Vehicle Specifications – Electric Vehicles on page 59.**
7. Perform the Pre-Operation and Daily Safety Checklist on page 32.

---

## MAINTENANCE

---

### See General Warnings on page 19.

To ensure trouble-free vehicle performance, it is very important to follow an established preventive maintenance program. Regular and consistent vehicle maintenance can prevent vehicle downtime and expensive repairs that can result from neglect. Use the Pre-Operation and Daily Safety Checklist on page 32 and the following Periodic Service Schedules and Periodic Lubrication Schedules to keep the vehicle in proper working condition.

Any vehicle not functioning correctly should be removed from use until it is properly repaired. This will prevent further damage to the vehicle and avoid the possibility of injury due to unsafe conditions.

Contact your local Club Car distributor/dealer to perform all repairs and semiannual and annual periodic service.

### **WARNING**

- If any problems are found during scheduled inspection or service, do not operate the vehicle until repairs are made. Failure to make necessary repairs could result in fire, property damage, severe personal injury, or death.
- Hot! Do not attempt to service hot engine, motor, or exhaust system. Attempting to do so could cause severe burns.
- Do not work on vehicle powertrain or under the cargo bed when it is loaded.

#### Gasoline vehicles only:

- Moving parts: Do not attempt to service gasoline vehicle while the engine is running.
- Turn the fuel shut-off valve to the closed (OFF) position (Figure 22, Page 41).
- To avoid unintentionally starting the vehicle, before servicing always disconnect the battery, negative (-) cable first (Figure 1, Page 21) and disconnect the spark plug wire from the spark plug.
- Frame ground – Do not allow tools or other metal objects to contact frame when disconnecting batteries or other electrical wiring. Never allow a positive wire to touch the vehicle frame, engine, or other metal component.

---

## PERIODIC SERVICE SCHEDULES

---

### **WARNING**

- Service, repairs, and adjustments must be made per instructions in the maintenance and service manual.

**NOTE:** If the vehicle is constantly subjected to heavy use or severe operating conditions, the preventive maintenance procedures should be performed more often than recommended in the periodic service and lubrication schedules.

*Both the Periodic Service Schedules and Periodic Lubrication Schedules must be followed to keep vehicle in optimum operating condition.*

PERIODIC SERVICE SCHEDULE – ELECTRIC VEHICLES		
REGULAR INTERVAL	SERVICE	
Daily service by owner	Batteries	Charge batteries (after each use only).
Weekly service by owner	Batteries	Check electrolyte level. Add water if necessary. <b>See page 49.</b>
Monthly service by owner or trained technician	Batteries	Wash battery tops and clean terminals with baking soda/water solution.
	Tires	Check air pressure and adjust if necessary. <b>See Vehicle Specifications – Electric Vehicles on page 59.</b>
	General vehicle	Wash battery compartment and underside of vehicle.
Semiannual service by trained technician only (or every 50 hours of operation, whichever comes first)	Brake system	Check brake shoes; replace if necessary. <b>See Section 6 – Wheel Brake Assemblies in the appropriate maintenance and service manual.</b>
		Lubricate brake slides per Lubrication Schedule. <b>See Section 6 – Wheel Brake Assemblies in the appropriate maintenance and service manual.</b>
		Check brake cables for damage; replace if necessary.
	Electrical wiring and connections	Check for tightness and damage.
	Forward/Reverse switch	Check condition of contacts and wire connections; make sure connections are tight.
	Front wheel alignment and camber	Check and adjust if required. <b>See Section 7 – Steering and Front Suspension in the appropriate maintenance and service manual.</b>
	Motor controller output regulator (MCOR)	Check for loose hardware, cracks, or other damage.
Annual service by trained technician only (or every 100 hours of operation, whichever comes first)	Batteries	If batteries are not performing as expected, see Section 13 – Batteries in the appropriate maintenance and service manual.

PERIODIC SERVICE SCHEDULE – GASOLINE VEHICLES		
REGULAR INTERVAL	SERVICE	
Monthly service by owner or trained technician	Engine	Check engine oil level; change if necessary. <b>See Periodic Lubrication Schedules on page 46.</b> Dispose of used oil properly.
		Check engine cooling air intake; visually inspect unshrouded area around engine exhaust for grass and debris and clean if necessary.
	Tires	Check air pressure and adjust if necessary. <b>See Vehicle Specifications – Electric Vehicles on page 59.</b>
	General vehicle	Wash engine compartment and underside of vehicle. Do not wash engine when hot.
Semiannual service by trained technician only (or every 50 hours of operation, whichever comes first)	Battery	Clean terminals and wash dirt from casing. Check electrolyte level. <b>See page 55.</b>
	Front wheel alignment and camber	Check and adjust if necessary. <b>See Section 7 – Steering and Front Suspension in the appropriate maintenance and service manual.</b>
	Electrical wiring and connections	Check for tightness and damage.
	Brake system	Check brake shoes; replace if necessary. <b>See Section 6 – Wheel Brake Assemblies in the appropriate maintenance and service manual.</b>
		Lubricate brake slides per Lubrication Schedule. <b>See Section 6 – Wheel Brake Assemblies in the appropriate maintenance and service manual.</b>
Check brake cables for damage; replace if necessary.		
Annual service by trained technician only (or every 100 hours of operation, whichever comes first)	Engine	Check for leaks around gaskets, fill plugs, etc.
		Inspect, clean, and regap spark plug; replace if necessary.
	Engine air intake system	Check air filter element; clean or replace if necessary. Dispose of used filter element properly.
		Check clamps for tightness. Check hose for cracks.
General vehicle	Check for loose hardware and tighten if necessary.	
Two year service by trained technician only (or every 200 hours of operation, whichever comes first)	Fuel filters	Replace. Dispose of used filters properly.

**⚠ WARNING**

- If any problems are found during scheduled inspection or service, do not operate the vehicle until repairs are made. Failure to make necessary repairs could result in fire, property damage, severe personal injury, or death.

## PERIODIC LUBRICATION SCHEDULES

PERIODIC LUBRICATION SCHEDULE – ELECTRIC VEHICLES			
REGULAR INTERVAL	SERVICE	LUBRICATION POINTS	RECOMMENDED LUBRICANT
Semiannually by owner or trained technician (or every 50 hours of operation, whichever comes first)	Brake pedal shaft bearings	1	Dry Moly Lube (CCI P/N 1012151)
	Brake linkage and pivots	2	Dry Moly Lube (CCI P/N 1012151)
	Accelerator pivot rod supports	3	Dry Moly Lube (CCI P/N 1012151)
	Charger receptacle (Villager vehicles only) Forward/Reverse switch contacts (PowerDrive vehicles only)	4	WD-40
	Brake slides	5	Dry Moly Lube (CCI P/N 1012151)
	Front suspension (5 fittings)	6	Chassis Lube – EP NLGI Grade 2
Annually by trained technician only (or every 100 hours of operation, whichever comes first)	Check/fill transaxle to plug level	7	22 oz. (0.67 liters) SAE 30 WT. API Class SE, SF, or SG Oil (or higher)
	Inspect front wheel bearings (Repack if necessary) (four-wheel brake vehicles only)	8	Chassis Lube – EP NLGI Grade 2

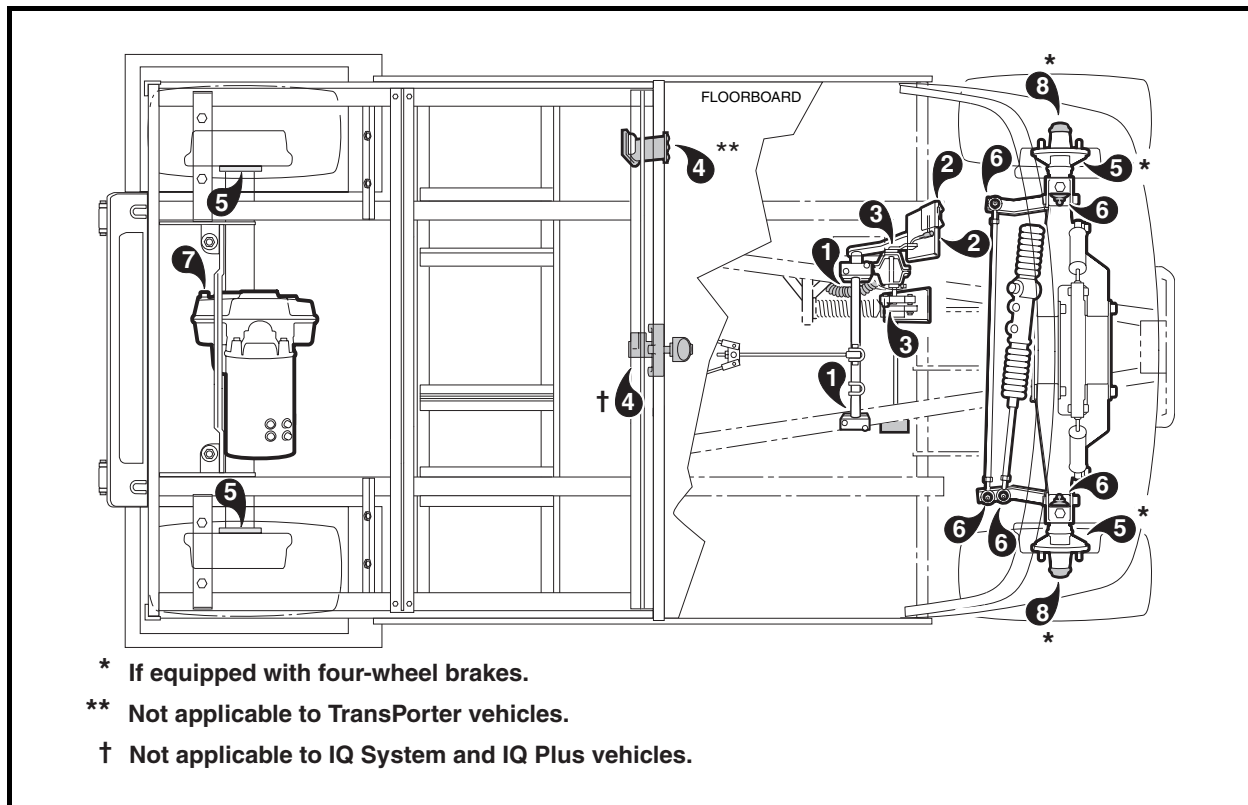

Figure 25 Lubrication Points – Electric Vehicles

PERIODIC LUBRICATION SCHEDULE – GASOLINE VEHICLES			
REGULAR INTERVAL	SERVICE	LUBRICATION POINTS	RECOMMENDED LUBRICANT
Semiannually by owner or trained technician (or every 50 hours of operation, whichever comes first)	Brake pedal shaft bearings	1	Dry Moly Lube (CCI P/N 1012151)
	Brake linkage and pivots	2	Dry Moly Lube (CCI P/N 1012151)
	Accelerator push rod pivots, mounts, and shifter cable pivots	3	Dry Moly Lube (CCI P/N 1012151)
	Front suspension (5 fittings)	4	Chassis Lube (EP NLGI Grade 2)
	Brake slides	5	Dry Moly Lube (CCI P/N 1012151)
Annually by trained technician only (or every 100 hours of operation, whichever comes first)	Check/fill unitized transaxle to plug level	6	27 oz. (0.8 liters) 80-90 WT. API Class GL-3 or 80-90 WT. AGMA Class EP Gear Lube
	Inspect front wheel bearings (Repack as necessary) (four-wheel brake vehicles only)	7	Chassis Lube – EP NLGI Grade 2
First change 100 hours – additional change every 200 hours of operation or annually, whichever comes first.	Change engine oil and oil filter	8	32 oz. (0.95 liters) without filter; 38 oz. (1.12 liters) with filter. See Oil Viscosity on page 56.

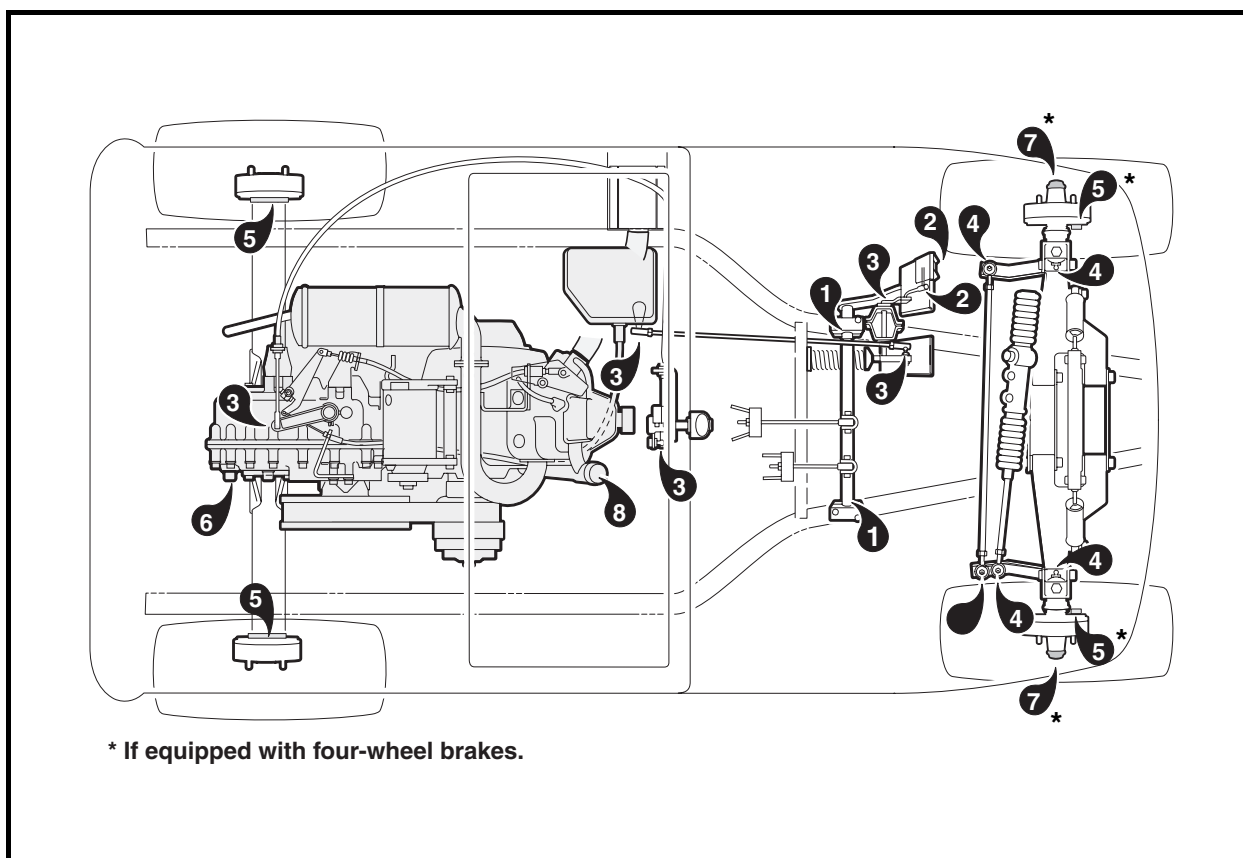

Figure 26 Lubrication Points – Gasoline Vehicles

---

## VEHICLE CONTROLLER – ELECTRIC VEHICLES

---

The Club Car electric vehicle is equipped with solid state speed controllers. In order to properly service and maintain the solid state speed controller vehicle, it is necessary to understand the electrical circuitry and the functions of all components in the system. Therefore, if any repair or service is required, Club Car recommends that it be performed by an authorized Club Car distributor/dealer using Club Car OEM parts.

---

## BATTERIES – ELECTRIC VEHICLES

---

### **DANGER**

- **Battery – Explosive gases! Do not smoke! Keep sparks and flames away from vehicle and service area. Tools, wires, and metal objects can cause sparks when shorted across a battery. Follow all instructions carefully when dealing with batteries.**
- **Charge batteries in a well-ventilated area only. Batteries emit hydrogen while being charged. Hydrogen is an explosive gas and must never exceed a level of 2% of the air.**
- **Battery – Poison! Contains acid! Causes severe burns. Avoid contact with skin, eyes, or clothing. Antidotes:**
  - **External: Flush with water. Call a physician immediately.**
  - **Internal: Drink large quantities of milk or water followed with milk of magnesia or vegetable oil. Call a physician immediately.**
  - **Eyes: Flush with water for 15 minutes. Call a physician immediately.**

### **WARNING**

- **Wear safety glasses or approved eye protection when servicing the vehicle. Wear a full face shield and rubber gloves when working with batteries.**
- **Use insulated tools when working around batteries or electrical connections.**
- **Ensure battery connections are clean and properly tightened. See Battery Care on page 49.**
- **Use only 4-gauge (AWG) wires with low-resistance terminals to replace battery wires on IQ Plus models.**

### **CAUTION**

- **Turn off all accessories before charging batteries.**

**NOTE:** *Recycle or dispose of discarded batteries in accordance with local, state and federal regulations.*

Club Car electric vehicles use deep-cycle batteries. Automotive batteries should never be used in electric vehicles.

New batteries will not deliver their full capabilities until they have been discharged and recharged 20 to 50 times. To obtain the maximum service life from new batteries, restrict the use of vehicles with new batteries to one hour of operation between charges for the first two months the vehicle is in service. Batteries should be fully charged before first use of new vehicle, before first use of a vehicle after storage, and before releasing vehicle for use each day.

## BATTERY CARE

To keep batteries in good working condition, follow this maintenance program on a regular basis. Proper battery maintenance is critical not only for good performance, but also for safe operation. **See following WARNING.**

### **⚠ WARNING**

- **Ensure battery connections are clean and properly tightened.**
  - **Use only 4-gauge (AWG) wires with low-resistance terminals to replace battery wires on IQ Plus models.**
  - **If battery wire terminals are damaged or corroded, they should be replaced or cleaned as necessary. Failure to do so may cause them to overheat during operation.**
1. Batteries should be kept clean and free of corrosion. Wash tops and terminals of batteries with a solution of baking soda and water (1 cup (237 mL) baking soda per gallon (3.8 L) of water). Rinse solution off batteries. Do not allow this solution to enter the batteries. Be sure terminals are tight. Let the terminals dry and then spray them with Battery Terminal Protector Spray (CCI P/N 1014305).

**NOTE:** *Dispose of waste water properly.*

2. The electrolyte level in the batteries should be checked weekly (**Figure 27**). Add water only after charging unless the electrolyte level is below the top of the plates. In this case, add just enough water to cover the plates, charge and then check the level again. Never charge batteries if plates are exposed above electrolyte level. For best battery life, use only distilled water.

**NOTE:** *A battery watering gun or bottle is available at many auto parts dealers.*

3. The hold-down straps should be tight enough so that the batteries do not move while the vehicle is in motion, but not so tight as to crack or buckle the battery case. Tighten hold-down retaining nuts to 40 in-lb (4.5 N-m). The terminal connections should be clean and tight, and any worn insulation or frayed wires should be replaced. Tighten battery terminals to 110 in-lb (12.4 N-m).
4. After use, the batteries should be placed on charge. The batteries should never be left discharged any longer than absolutely necessary (do not leave batteries discharged overnight).

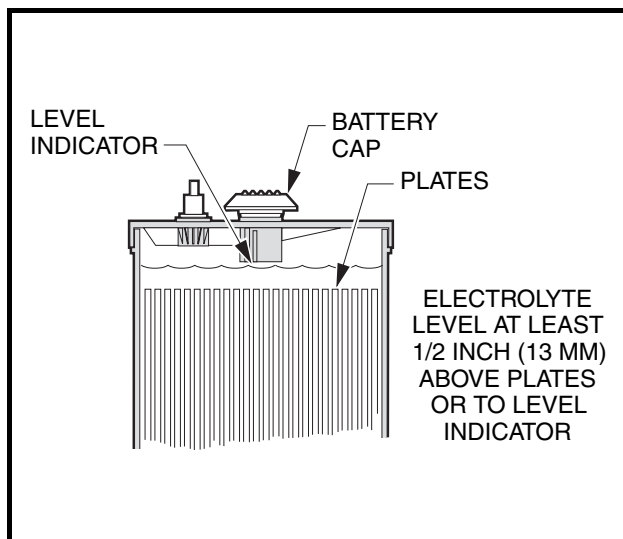

**Figure 27** Electric Battery Electrolyte Level

---

## BATTERY CHARGER – ELECTRIC VEHICLES

---

See General Warnings on page 19.

### **DANGER**

- The charging area must be ventilated. Hydrogen level in the air must never exceed 2%. The total volume of air in the charging area must be changed five times per hour. Exhaust fans should be located at the highest point of the roof. Contact a local HVAC engineer.
- Do not charge the vehicle batteries with the vehicle covered or enclosed. Any enclosure or cover should be removed or unzipped and pulled back when batteries are being charged. An accumulation of hydrogen gas could result in an explosion.

### **WARNING**

- Only trained technicians should repair or service the charger. Contact a Club Car distributor/ dealer.
- Each charger should have its own dedicated 15 or 20 ampere separately protected (circuit breaker or fuse) single phase branch circuit, in accordance with all applicable electrical codes for the location.
- Have worn, cut, or damaged power cords or wires replaced immediately.
- Be sure that all wire connections at the receptacle and fuse link are clean and tight.
- Do not expose to rain or any liquid. Keep the charger dry.
- Do not use near fuels, grain dust, solvents, thinners, or other flammables. Chargers can ignite flammable materials and vapors.
- Connect the charger AC supply cord to a properly grounded, three-wire outlet of the proper voltage and frequency as shown on the charger.
- Do not use an adapter to plug the charger with a three-prong plug into a two-prong outlet. Improper connection of the equipment-grounding conductor can result in a fire or an electrical shock.
- Use only an extension cord or electrical outlet that will accept a three-prong plug. Extension cord should be a three-wire no. 12 AWG (American Wire Gauge) or No. 14 SWG (British Standard Wire Gauge), and be as short as possible. The use of an improper extension cord could result in fire or an electrical shock.
- Do not operate the charger if it has received a sharp blow, was dropped, or otherwise damaged in any way.
- Never push objects of any kind into the charger through cabinet slots. They may touch dangerous voltage points or cause an electrical short circuit that could result in fire or electrical shock.
- Do not connect a stationary charger to the receptacle if the charger cord, plug, or the vehicle receptacle is broken, damaged, or does not make a good electrical connection. Fire or personal injury can result. Have a qualified technician repair or replace it immediately.
- When using a stationary charger, do not pull on the DC cord (Figure 29, Page 53). Do not twist, rock, or bend the plug. To disconnect the plug from the receptacle, grasp the plug, not the cord, and slowly pull it straight out of the receptacle (Figure 28, Page 53).
- When the charger is on, the charger DC cord may be disconnected from the vehicle receptacle *slowly*. Jerking or pulling the DC cord out quickly could cause arcing and burning which could damage the plug and receptacle and could cause batteries to explode.

WARNING CONTINUED ON NEXT PAGE...

** WARNING**

- **Do not use a charger if:**
  - **The plug is too loose or does not make a good connection.**
  - **The plug and receptacle feel hotter than normal during charge.**
  - **The plug pins or contacts are bent or corroded.**
  - **The plug, receptacle or cords are cut, worn, have any exposed wires, or are damaged in any way.**
- **Using a charger with any of the above symptoms could result in fire, property damage, personal injury, or death.**
- **Do not block or cover the charger ventilation slots. The slots provide ventilation and prevent the charger from overheating.**
- **Do not allow clothing, blankets, or other material to cover the charger.**
- **Do not allow the charger to operate for more than 30 minutes at 19 or more amperes.**
- **Install surge arrestors on incoming AC power lines. Surge arrestors will help protect electrical components in the charger and on the vehicle from all but direct or close lightning strikes.**

**NOTE:** *Because the vehicle's onboard computer (OBC) has a storage charge feature that automatically checks and recharges the batteries as necessary every 15 days, the charger can remain plugged to a PowerDrive, IQ System, or IQ Plus vehicle throughout the storage period.*

*PowerDrive System 48 vehicles only: Shortly after charging begins, battery chargers will shut off in order to run a self-diagnostic program (ammeter will drop to zero). Charging will resume in a few moments (ammeter returns to previous rate of charge). This will be repeated at one hour and at two hours into the charge cycle.*

*IQ System and IQ Plus Vehicles: At one hour and at two hours into the charge cycle, the charger will shut off in order to run a self-diagnostic program (ammeter will drop to zero). Charging will resume in a few moments (ammeter returns to previous rate of charge).*

Each electric vehicle is supplied with either a fully automatic, stationary, battery charger (Villager vehicles) or fully automatic onboard charger (TransPorter) as standard equipment. The AC cord from the charger should be connected to a source capable of supplying 15 amperes minimum per charger.

To reduce the risk of electric shock, the battery charger must be grounded. The charger is equipped with an AC electric cord having an equipment-grounding conductor and a grounding type plug. The AC plug must be connected to an appropriate receptacle that is properly installed and grounded in accordance with the National Electrical Code and all local codes and ordinances. See the owner's manual supplied with the battery charger for specific operating instructions before using the charger.

The use of an extension cord with the charger should be avoided. If an extension cord must be used, use a three-conductor no. 12 AWG (American Wire Gauge) or no. 14 SWG (British Standard Wire Gauge), heavy-duty cord with ground, properly wired and in good electrical condition. Keep it as short as possible (no more than 12 feet (3.7 m)). Place all cords so they will not be stepped on, tripped over, or otherwise subject to damage or stress.

Ensure that the charger ventilation slots are unobstructed and that there is adequate ventilation.

## CHARGING BATTERIES

**NOTE:** When temperatures fall below 65 °F (18.3 °C), batteries charged in unheated areas should be placed on charge as soon as possible after use. Batteries are warmest immediately after use, while cold batteries require more time to fully charge.

- **Villager (stationary charger)**

Insert the charger AC plug into a dedicated AC receptacle that is properly grounded and wired in accordance with the National Electric Code and all local codes and ordinances. Then insert the charger DC plug into the vehicle receptacle. The charger will turn on two to ten seconds later (**Figure 28, Page 53**).

- **TransPorter (onboard charger)**

Insert the onboard charger AC plug into a dedicated AC receptacle that is properly grounded and wired in accordance with the National Electric Code and all local codes and ordinances. The charger will turn on two to ten seconds later.

Club Car battery chargers interact with the vehicle onboard computer. The computer records the amount of energy consumed during vehicle use. While the charger is plugged in, the vehicle's control circuit is locked out, preventing operation of the vehicle as well as the possibility of subsequent damage to the charger and the vehicle.

Once the lockout is actuated, the charger turns on. The onboard computer then records the amount of energy being returned to the batteries. When the optimum amount of energy needed to replenish the batteries is returned, the charger will turn off. The control circuit lockout remains activated until the charger plug is disconnected from the vehicle.

PowerDrive and IQ Plus battery chargers are not interchangeable, nor can they be used with other Club Car models or vehicles made by other manufacturers. Charger compatibility for each vehicle is as follows:

- PowerDrive System 48 and IQ System vehicles use the PowerDrive charger.
- IQ Plus vehicles use the IQ Plus charger.

As long as the charger is allowed to shut off by itself, the batteries will be fully charged. Overcharging and undercharging will normally be prevented.

### **CAUTION**

- **Only IQ Plus chargers should be used with IQ Plus vehicles. Long-term use of a PowerDrive battery charger with IQ Plus vehicles will damage the batteries.**

Batteries should be put on charge even if they have been used for only a short time (10 minutes). The charger is automatic and will turn off when batteries are fully charged. If the charger does not seem to be operating properly, or if the batteries seem weak, contact a Club Car distributor/dealer.

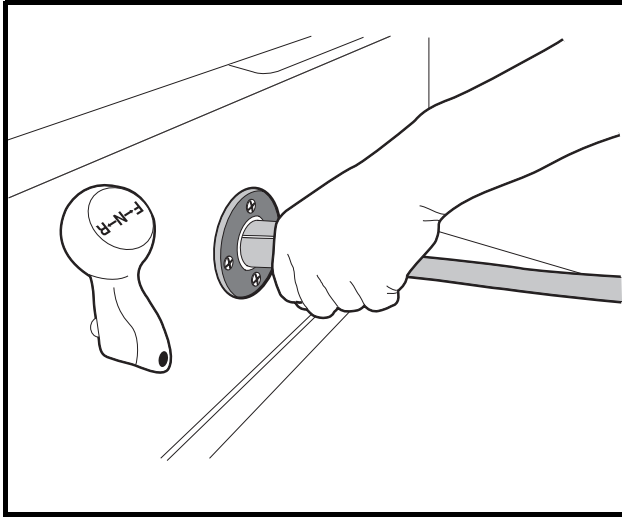

Figure 28 Correct Insertion of Charger DC Plug

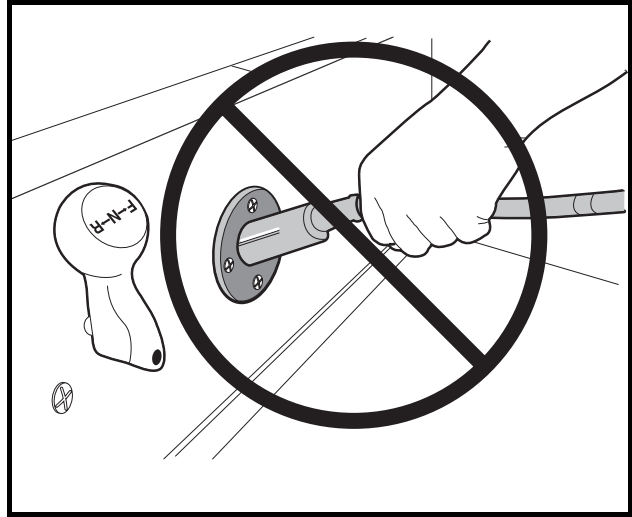

Figure 29 Incorrect Insertion of Charger DC Plug

## PLUG AND RECEPTACLE

**Villager vehicles:** The charger cord, plug, and receptacle are wear items and should be inspected daily. Visually inspect them for cracks, loose connections, and frayed wiring; they must be replaced when worn or damaged. If charger plug or receptacle show signs of corrosion or the plug is difficult to insert or remove, the receptacle contacts and plug terminals should be cleaned with a good electrical contact cleaner or lightly sprayed with WD-40® brand spray lubricant. The plug should then be inserted and removed several times to ensure ease of insertion, ease of removal, and good electrical contact. **See following NOTE.**

**NOTE:** If the warning tag has been damaged or removed from the DC cord, have it replaced immediately.

## RECEPTACLE FUSE LINK

**Villager vehicles:** As an additional feature to protect the batteries and charging circuit from an overload, the electric vehicle is equipped with a receptacle fuse link (**Figure 30**). If the charger does not come on when the vehicle is placed on charge, visually inspect the fuse link. **See following WARNING.**

### **⚠ WARNING**

- If the receptacle fuse link is blown, determine the source of the problem and correct it before replacing the fuse.
- Never modify wiring to bypass the gray sense lead fuse (**Figure 30**).

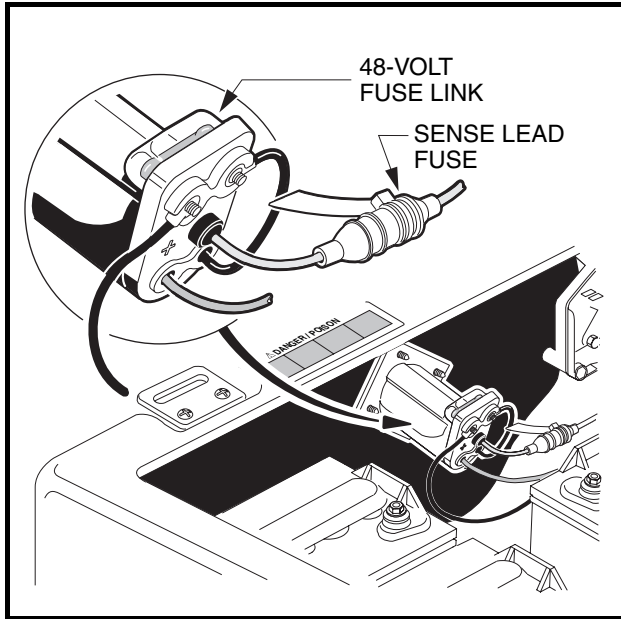

Figure 30 Receptacle Fuse Link

## BATTERY – GASOLINE VEHICLES

See General Warnings on page 19.

### **⚠ DANGER**

- **Battery – Explosive gases! Do not smoke. Keep sparks and flames away from the vehicle and service area. Ventilate when charging or operating vehicle in an enclosed area. Wear a full face shield and rubber gloves when working on or near batteries.**
- **Tools, wires and metal objects can cause sparks when shorted across battery.**
- **Follow all instructions carefully when working with batteries.**
- **Charge battery in a well-ventilated area only.**
- **Battery – Poison! Contains acid! Causes severe burns. Avoid contact with skin, eyes, or clothing. Antidotes:**
  - **External: Flush with water. Call a physician immediately.**
  - **Internal: Drink large quantities of milk or water followed with milk of magnesia or vegetable oil. Call a physician immediately.**
  - **Eyes: Flush with water for 15 minutes. Call a physician immediately.**

### **⚠ WARNING**

- **Do not jump start a dead battery using another battery and jumper cables.**

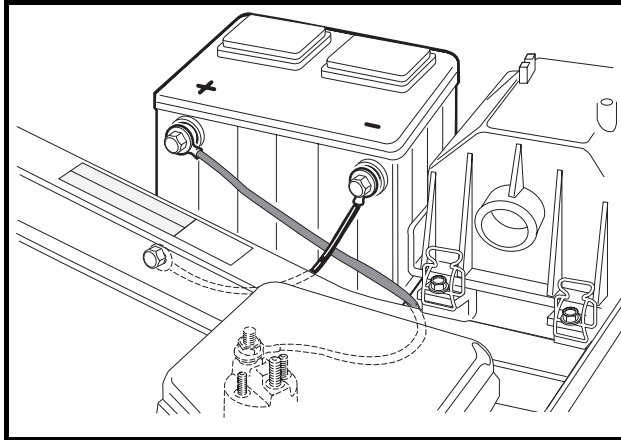

Figure 31 Battery

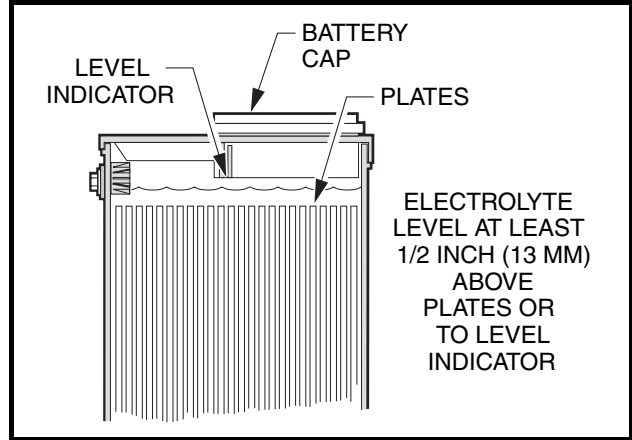

Figure 32 Gasoline Battery Electrolyte Level

The gasoline vehicle battery is a 12-volt, low-maintenance battery that requires infrequent watering (**Figure 31**). Any corrosion around the positive (+) or negative (–) terminals should be washed off with a solution of baking soda and water (1 cup (237 mL) per gallon (3.8 L) of water). Rinse solution off the battery. Do not allow this solution to get into the battery. Be sure terminals are tight (battery terminals should be tightened to 12 ft-lb (16 N·m)). Let the terminals dry and then spray them with Battery Terminal Protector Spray (CCI P/N 1014305). **See preceding WARNING and following CAUTION.**

### **⚠ CAUTION**

- If battery wire terminals are damaged or corroded, they should be replaced or cleaned as necessary. Failure to do so may cause them to overheat during operation.

Be sure battery clamp is properly tightened. Tighten to 12 ft-lb (16 N·m). A loose clamp may allow the battery to become damaged from vibration or jarring.

If battery appears weak, have it charged by a trained technician. The battery should never be left discharged any longer than absolutely necessary (do not leave battery discharged overnight).

## **ENGINE OIL – GASOLINE VEHICLES**

Even though the low oil warning light on the dash should illuminate if oil level becomes low, engine oil level should be checked monthly. Vehicle should be on a level surface when checking oil. Do not overfill with oil.

### **ENGINE OIL LEVEL CHECK**

1. Remove the oil level dipstick from the oil filler tube and wipe oil from stick (**Figure 33**). **See following CAUTION.**

### **⚠ CAUTION**

- Do not remove dipstick while engine is running.
2. Check oil by fully inserting the dipstick into the oil filler tube and immediately removing it.

3. If the oil level is at or below the low level mark on the dipstick gauge, add oil until the level is between low and full levels (safe level).
4. Reinsert dipstick into the oil filler tube.

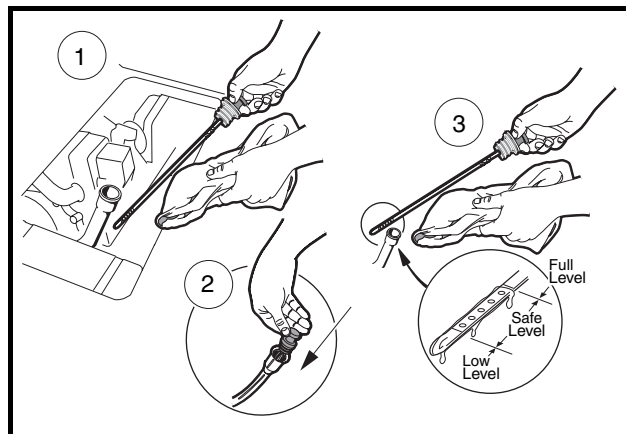

Figure 33 Engine Oil Level Check

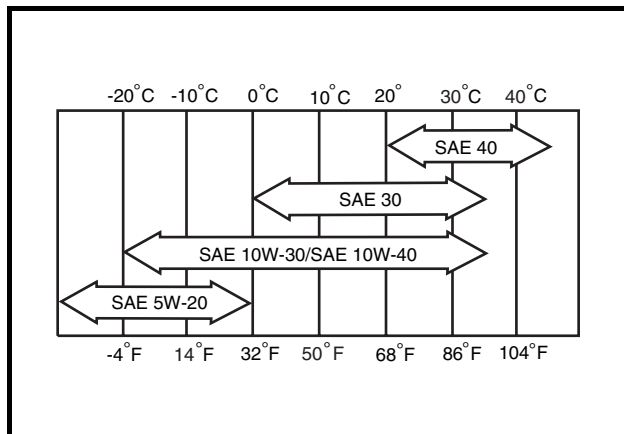

Figure 34 Oil Viscosity Chart

## OIL VISCOSITY

Choose the viscosity according to the temperature as indicated by the oil viscosity chart (Figure 34). See following NOTE.

**NOTE:** Using multi-grade oils (5W-20, 10W-30 and 10W-40) will increase oil consumption. Check oil level more frequently when using multi-grade oils.

## FUELING INSTRUCTIONS – GASOLINE VEHICLES

See General Warnings on page 19.

### **⚠ DANGER**

- Turn the key switch to the OFF position before fueling.
- Do not pour gasoline into fuel tank when engine is hot or while it is running.
- To avoid electric arc caused by static electricity, the fuel storage/pumping device must be grounded. If the pump is not grounded, the vehicle must be grounded to the pump before and during the fueling operation.
- If the vehicle has an all-weather enclosure installed, be sure the fuel tank is properly vented as shown (Figure 35).
- To avoid the possibility of fire, clean up any spilled gasoline before operating the vehicle.

### **⚠ CAUTION**

- To allow for expansion, do not fill higher than one inch from top of the fuel tank. Avoid spilling fuel.

**NOTE:** Whenever possible, avoid using oxygenated fuels and fuels that are blended with alcohol. Vehicles to be stored for extended periods should be prepared for storage as instructed. See **Preparing the Gasoline Vehicle for Extended Storage on page 40.**

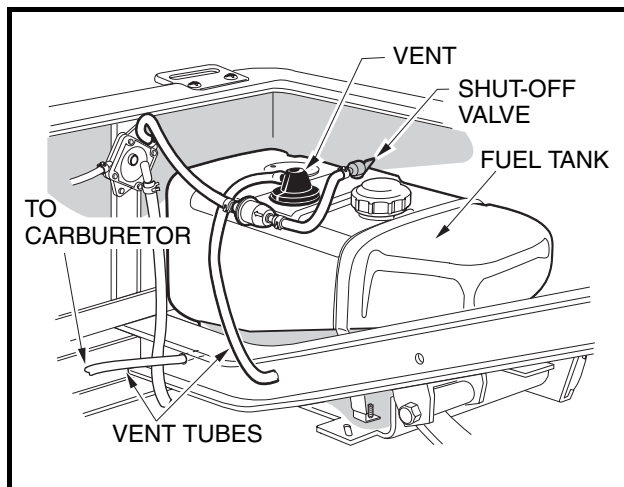

**Figure 35 Fuel Tank**

#### **DS Villager 4:**

1. Lift and remove the driver seat bottom. Proceed to Step 2.

#### **Villager 6, Villager 8, and TransPorter:**

1. Lift and remove the second forward-facing seat.
2. The fuel tank is located on passenger side of vehicle. Remove fuel cap and fill the fuel tank with fresh unleaded gasoline only. **See preceding CAUTION and NOTE.**
3. Replace fuel cap on tank. Ensure cap is securely tightened.
4. Replace seat bottom.

## **CLEANING THE VEHICLE**

Transportation vehicles are equipped with ArmorFlex® front bodies and either ArmorFlex or all-aluminum rear bodies. The four-passenger TransPorter vehicle has an aluminum cargo bed. The center bodies of Villager 6 and Villager 8 vehicles are ABS/DR acrylic material. Use only commercially available automotive cleaner with a sponge or soft cloth for normal cleaning. A garden hose at normal residential water pressure is adequate. To remove oxidation or discoloration from aluminum, use a commercially available aluminum cleaner paste and fine grade (No. 00) steel wool.

Club Car does not recommend any type of pressure washing or steam cleaning. Such a process (especially if the vehicle has an ArmorFlex rear body that has been removed) will expose electrical components to moisture. Moisture entering electrical components can result in water damage and subsequent component failure.

Use non-abrasive wax products. Battery acid, fertilizers, tars, asphalt, creosote, paint, or chewing gum should be removed immediately to prevent possible stains.

The center bodies of Villager 6 and Villager 8 vehicles are made of an ABS/DR acrylic material similar to the material used to manufacture hot tubs and shower/tub units. Cleaning and repair techniques for the center

body are the same as those used on conventional acrylic sheet. Repair kits, cleaning and polishing products may be purchased at any hardware store where ABS/DR acrylic (hot tubs and shower/tub units) are sold.

The seats of the vehicle will last longer with proper cleaning. Use a solution of 10% liquid soap and warm water applied with a soft cloth. For imbedded dirt, a soft bristle brush may be used. For heavy soiling, difficult stains or scratches, blemishes, or other body damage, see Section 4 of the maintenance and service manual.

**NOTE:** *Dispose of waste water properly.*

## ACCESSORIES

---

There is a complete line of accessory equipment available from Club Car and our dealers/distributors. You can obtain the name and phone number of your closest Club Car contact by visiting our web site at [www.clubcar.com](http://www.clubcar.com) and clicking the “*Dealer Locator*” link.

Care should be taken that these accessories are properly installed by trained technicians, and that they are used in the manner for which they were designed. **See following WARNING.**

### **WARNING**

---

- **Custom cab assemblies, weatherproof enclosures, door kits, and tinted windshields will not protect occupants from flying objects (golf balls, etc.).**

## SUBSEQUENT OWNER REGISTRATION

---

In the event a vehicle is bought as a used vehicle, we strongly urge the new owner to register the vehicle with Club Car. This will enable us to contact you if the need arises. Please send your name, address, and serial number(s) of the vehicle(s) to Club Car, Inc., P.O. Box 204658, Augusta, Georgia 30917-4658, Attention: Vehicle Registration.

## VEHICLE SPECIFICATIONS – ELECTRIC VEHICLES

SPECIFICATIONS	Villager 4 IQ System	Villager 6 Villager 8 IQ Plus	Villager 6 Villager 8 Power-Drive System 48	TransPorter 4 IQ Plus	TransPorter 4 Power-Drive System 48	TransPorter 6 IQ Plus	TransPorter 6 Power-Drive System 48
<b>POWER SOURCE</b>							
<b>Drive motor:</b> Direct drive, 48 volts DC, series-wound, 3.1 hp			.		.		.
<b>Drive motor:</b> Direct drive, 48 volts DC, shunt-wound, 3.2 hp	.						
<b>Drive motor:</b> Direct drive, 48 volts DC, shunt-wound, 3.7 hp		.		.		.	
<b>Transaxle:</b> Double reduction helical gear with 12.28:1 direct drive axle	.	.	.	.	.	.	.
<b>Electrical system:</b> 48 volts DC, reduced speed reverse	.	.	.	.	.	.	.
<b>Batteries:</b> High capacity, deep cycle, Trojan PowerDrive 8 volt, 117 min. capacity	.		.		.		.
<b>Batteries:</b> High capacity, deep cycle, Trojan 6 volt, 160 min. capacity		.		.		.	
<b>Batteries:</b> High capacity, deep cycle Trojan 12 volt	.						
<b>Charger:</b> Automatic, 17 amp; UL and CSA listed	.	.	.	.	.	.	.
<b>STEERING/SUSPENSION/BRAKES</b>							
<b>Steering:</b> Self-adjusting rack and pinion	.	.			.		.
<b>Suspension:</b> Front mono-leaf and rear multi-leaf springs with dual hydraulic shocks	.				.		.
<b>Suspension:</b> Front and rear multi-leaf springs with dual hydraulic shocks		.					
<b>Brakes:</b> Mechanical brake cable system to self-adjusting drum brakes on each rear wheel. Park brake is automatically released. Self-adjusting multi-latch ratchet and pawl	.						
<b>Brakes:</b> Mechanical brake cable system to manually adjusted drum brakes on all four wheels. Park brake is automatically released. Self-adjusting multi-latch ratchet and pawl			.		.		.
<b>BODY/CHASSIS</b>							
<b>Frame/Chassis:</b> Twin I-Beam welded aluminum	.	.			.		.
<b>Side and rear body:</b> All aluminum					.		.
<b>Front body:</b> ArmorFlex®	.	.			.		.
<b>Front body finish:</b> Matched paint finish over molded-in color	.	.			.		.
<b>Center body:</b> ABS/DR acrylic		.					
<b>Tires:</b> 18 x 8.50 - 8 tubeless, 4 ply rated load range front and rear	.						
<b>Tires:</b> 18 x 8.50 - 8 tubeless, 6 ply rated load range front and rear		.			.		.
<b>DIMENSIONS/WEIGHT</b>							
<b>Overall length</b>	100 in. (254 cm)	Vil. 6: 124 in. (315 cm) Vil. 8: 157 in. (398 cm)		134 in. (340 cm)		133 in. (338 cm)	
Specifications continued on next page . . .							

<b>SPECIFICATIONS</b>	<b>Villager 4 IQ System</b>	<b>Villager 6 Villager 8 IQ Plus</b>	<b>Villager 6 Villager 8 Power-Drive System 48</b>	<b>TransPorter 4 IQ Plus</b>	<b>TransPorter 4 Power-Drive System 48</b>	<b>TransPorter 6 IQ Plus</b>	<b>TransPorter 6 Power-Drive System 48</b>
<b>Overall width</b>	47.3 in. (120 cm)	47.3 in. (120 cm)		49.3 in. (125 cm)		49.3 in. (125 cm)	
<b>Overall height (at steering wheel)</b>	48 in. (122 cm)	48 in. (122 cm)		48 in. (122 cm)		48 in. (122 cm)	
<b>Wheelbase</b>	65.5 in. (166 cm)	Vil. 6: 98.5 in. (250 cm) Vil. 8: 131.5 in. (334 cm)		98.5 in. (250 cm)		98.5 in. (250 cm)	
<b>Ground clearance</b>	4.5 in. (11 cm)	4.5 in. (11 cm)		4.5 in. (11 cm)		4.5 in. (11 cm)	
<b>Front wheel tread</b>	34.5 in. (88 cm)	34.5 in. (88 cm)		34.5 in. (88 cm)		34.5 in. (88 cm)	
<b>Rear wheel tread</b>	38.5 in. (98 cm)	38.5 in. (98 cm)		38.5 in. (98 cm)		38.5 in. (98 cm)	
<b>Weight:</b> Standard electric powered vehicle	885 lb. (401 kg)	Vil. 6: 1127 lb. (511 kg) Vil. 8: 1241 lb. (563 kg)	Vil. 6: 950 lb. (431 kg) Vil. 8: 1064 lb. (483 kg)	1286 lb. (583 kg)	1060 lb. (481 kg)	1286 lb. (583 kg)	1077 lb. (489 kg)
<b>Forward speed</b>	12-15 mph (19-24 km/h)	12-15 mph (19-24km/h)		12-15 mph (19-24 km/h)		12-15 mph (19-24 km/h)	
<b>Curb clearance circle (diameter)</b>	17 ft.-6 in. (533 cm)	Vil. 6: 24 ft.-8 in. (752 cm) Vil. 8: 32 ft.-7 in. (993 cm)		24 ft.-8 in. (752 cm)		24 ft.-8 in. (752 cm)	
<b>Turning radius per SAE J 695</b>	68 in. (173 cm)	Vil. 6: 129 in. (328 cm) Vil. 8: 191 in. (485 cm)		129 in. (328 cm)		129 in. (328 cm)	
<b>Intersecting aisle clearance</b>	72 in. (183 cm)	Vil. 6: 89.8 in. (228 cm) Vil. 8: 108 in. (274 cm)		89.8 in. (228 cm)		89.8 in. (228 cm)	
<b>Floorboard height</b>	11.8 in. (30 cm)	11.8 in. (30 cm)		11.8 in. (30 cm)		11.8 in. (30 cm)	
<b>Seat height</b>	29.5 in. (75 cm)	30 in. (76 cm)		30 in. (76 cm)		30 in. (76 cm)	
<b>Load bed height</b>				27 in. (69 cm)			
<b>Load bed size (flat bed dimensions)</b>				35.8 in.x 44.3 in. (91x112 cm)			
<b>Vehicle rated capacity (level surface only)</b>	800 lb. (363 kg)	1500 lb. (680 kg)		1500 lb. (680 kg)		1500 lb. (680 kg)	
<b>Standard seating capacity</b>	4	Vil. 6: 6 Vil. 8: 8		4		6	
<b>LIQUID CAPACITIES</b>							
<b>Transaxle</b>	22 oz. (0.67 liters)	22 oz. (0.67 liters)					
<b>TIRE PRESSURE</b>							
<b>Front and rear</b>	12-14 psi (0.83-0.96 Bars)	30-34 psi (2.07-2.34 Bars)					

## VEHICLE SPECIFICATIONS – GASOLINE VEHICLES

SPECIFICATIONS	DS Villager 4 Pedal-Start Gasoline	Villager 6 Villager 8 Key-Start Gasoline	TransPorter 4 Key-Start Gasoline	TransPorter 6 Key-Start Gasoline
<b>POWER SOURCE</b>				
<b>Engine:</b> 4 cycle, OHV, 286 cc, 9 hp rated, single cylinder, air cooled, with pressure lubrication system	.			
<b>Engine:</b> 4 cycle, OHV, 351 cc, 11 hp rated, single cylinder, air cooled, with pressure lubrication system		.	.	.
<b>Fuel system:</b> Side draft carburetor with float bowl, fixed jets, fuel filter, and impulse fuel pump	.	.	.	.
<b>Governor:</b> Automatic ground speed sensing, internally geared in unitized transaxle	.	.	.	.
<b>Ignition:</b> Transistor electronic ignition with electronic RPM limiter	.	.	.	.
<b>Unitized transaxle:</b> Fully synchronized forward and reverse with neutral (11.8:1 forward, 17.1:1 reverse)	.	.	.	.
<b>Electrical system:</b> 12 volt, 500 cca at 0 °F (–17.8 °C), 650 cca at 32 °F (0 °C), 105 minute reserve capacity and 35 amp charging capacity	.	.	.	.
<b>Torque converter:</b> Automatic, variable speed, dry type	.	.	.	.
<b>STEERING/SUSPENSION/BRAKES</b>				
<b>Steering:</b> Self-adjusting rack and pinion	.	.	.	.
<b>Suspension:</b> Front mono-leaf and rear multi-leaf springs with dual hydraulic shocks	.			
<b>Suspension:</b> Front and rear multi-leaf springs with dual hydraulic shocks		.	.	.
<b>Brakes:</b> Mechanical brake cable system to self-adjusting drum brakes on each rear wheel. Park brake is automatically released. Self-adjusting multi-latch ratchet and pawl	.			
<b>Brakes:</b> Mechanical brake cable system to manually adjusted drum brakes on all four wheels. Park brake is automatically released. Self-adjusting multi-latch ratchet and pawl		.	.	.
<b>BODY/CHASSIS</b>				
<b>Frame/Chassis:</b> Twin I-Beam welded aluminum	.	.	.	.
<b>Side and rear Body:</b> All aluminum			.	.
<b>Front body:</b> ArmorFlex®	.	.	.	.
<b>Front body finish:</b> Matched paint finish over molded-in color	.	.	.	.
<b>Center body:</b> ABS/DR acrylic		.		
<b>Tires:</b> 18 x 8.50 - 8 tubeless, 4 ply rated load range front and rear	.			
<b>Tires:</b> 18 x 8.50 - 8 tubeless, 6 ply rated load range front and rear		.	.	.
<b>DIMENSIONS/WEIGHT</b>				
<b>Overall length</b>	100 in. (254 cm)	Vil. 6: 124 in. (315 cm) Vil. 8: 157 in. (398 cm)	134 in. (340 cm)	133 in. (338 cm)
<b>Overall width</b>	47.3 in. (120 cm)	47.3 in. (120 cm)	49.3 in. (125 cm)	49.3 in. (125 cm)
<b>Overall height (at steering wheel)</b>	48 in. (122 cm)	48 in. (122 cm)	48 in. (122 cm)	48 in. (122 cm)
<b>Specifications continued on next page . . .</b>				

Vehicle Specifications – Gasoline Vehicles

<b>SPECIFICATIONS</b>	<b>DS Villager 4 Pedal-Start Gasoline</b>	<b>Villager 6 Villager 8 Key-Start Gasoline</b>	<b>TransPorter 4 Key-Start Gasoline</b>	<b>TransPorter 6 Key-Start Gasoline</b>
<b>Wheelbase</b>	65.5 in. (166 cm)	Vil. 6: 98.5 in. (250 cm) Vil. 8: 131.5 in. (334 cm)	98.5 in. (250 cm)	98.5 in. (250 cm)
<b>Ground clearance</b>	4.5 in. (11 cm)	4.5 in. (11 cm)	4.5 in. (11 cm)	4.5 in. (11 cm)
<b>Front wheel tread</b>	34.5 in. (88 cm)	34.5 in. (88 cm)	34.5 in. (88 cm)	34.5 in. (88 cm)
<b>Rear wheel tread</b>	38.5 in. (98 cm)	38.5 in. (98 cm)	38.5 in. (98 cm)	38.5 in. (98 cm)
<b>Weight:</b> Standard gasoline-powered vehicle (without gasoline in fuel tank)	633 lb. (287 kg)	Vil. 6: 745 lb. (338 kg) Vil. 8: 866 lb. (393 kg)	825 lb. (374 kg)	842 lb. (381 kg)
<b>Forward speed</b>	12-15 mph (19-24 km/h)	14-16 mph (23-26 km/h)	14-16 mph (23-26 km/h)	14-16 mph (23-26 km/h)
<b>Curb clearance circle (diameter)</b>	17 ft.-6 in. (533 cm)	Vil. 6: 24 ft.-8 in. (752 cm) Vil. 8: 32 ft.-7 in. (993 cm)	24 ft.-8 in. (752 cm)	24 ft.-8 in. (752 cm)
<b>Turning radius per SAE J 695</b>	68 in. (173 cm)	Vil. 6: 129 in. (328 cm) Vil. 8: 191 in. (485 cm)	129 in. (328 cm)	129 in. (328 cm)
<b>Intersecting aisle clearance</b>	72 in. (183 cm)	Vil. 6: 89.8 in. (228 cm) Vil. 8: 108 in. (274 cm)	89.8 in. (228 cm)	89.8 in. (228 cm)
<b>Floorboard height</b>	11.8 in. (30 cm)	11.8 in. (30 cm)	11.8 in. (30 cm)	11.8 in. (30 cm)
<b>Seat height</b>	29.5 in. (75 cm)	30 in. (76 cm)	30 in. (76 cm)	30 in. (76 cm)
<b>Load bed height</b>			27 in. (69 cm)	
<b>Load bed size (flat bed dimensions)</b>			35.8 in.x 44.3 in. (91x112 cm)	
<b>Vehicle rated capacity (level surface only)</b>	800 lb. (363 kg)	1500 lb. (680 kg)	1500 lb. (680 kg)	1500 lb. (680 kg)
<b>Standard seating capacity</b>	4	Vil. 6: 6 Vil. 8: 8	4	6
<b>LIQUID CAPACITIES</b>				
<b>Engine crankcase without filter</b>	32 oz. (0.95 liters)			
<b>Engine crankcase with filter</b>	38 oz. (1.12 liters)			
<b>Unitized transaxle</b>	27 oz. (0.8 liters)			
<b>Fuel tank</b>	7 gallons (26.5 liters)			
<b>TIRE PRESSURE</b>				
<b>Front and rear</b>	12-14 psi (0.83-0.96 Bars)	30-34 psi (2.07-2.34 Bars)	30-34 psi (2.07-2.34 Bars)	30-34 psi (2.07-2.34 Bars)

# CLUB CAR<sup>®</sup> LIMITED TWO YEAR WARRANTY FOR 2006 TRANSPORTATION AND UTILITY VEHICLES

---

## 1. WARRANTY:

CLUB CAR, INC., ("CLUB CAR") hereby warrants to the Original Retail Purchaser that its new 2006 Model Transportation and Utility Vehicles purchased from CLUB CAR or an authorized dealer shall be free from defects in material and workmanship under normal use and service as a transportation or utility vehicle for the periods stated below, subject to the provisions, limitations and exclusions contained in this limited warranty.

**LIMITED TWO YEAR / 2000 HOUR WARRANTY:** The engine assembly, unitized transaxle assembly (gasoline vehicle), motor, transaxle assembly (electric vehicle), main frame assembly, hydraulic dump kit, Custom Cab assembly and doors, and Driving Range Protective Enclosure are warranted with respect to parts and labor against defects in material and workmanship for a period of two years or 2000 hours of operation, whichever first occurs, from the date of purchase.

**LIMITED ONE YEAR / 1000 HOUR WARRANTY:** All remaining components of the vehicle not specified otherwise, the Portable Refreshment Center, and all other original equipment options and accessories supplied by CLUB CAR are warranted with respect to parts and labor against defects in material and workmanship for a period of one year or 1000 hours of operation, whichever first occurs, from the date of purchase.

This limited warranty covers material, workmanship and repair labor cost as to those items specifically listed above for the periods specified. Such repair labor shall be performed only by CLUB CAR, its authorized dealers, or a service agency approved by CLUB CAR.

IF THE WARRANTY REGISTRATION FORM IS NOT COMPLETED AND RETURNED TO CLUB CAR AT THE TIME OF THE ORIGINAL RETAIL SALE, PURCHASER MUST PROVIDE PROOF OF DATE OF PURCHASE WITH ANY WARRANTY CLAIM.

## 2. EXCLUSIONS:

Excluded from any CLUB CAR warranty are all fuses, filters, decals (except safety decals), spark plugs, light bulbs, lubricants, trim pieces, seats, routine wear items such as the charger plug and receptacle, brake shoes, belts, brushes, bushings, engine mounts, mats and pads, maintenance adjustments, cosmetic deterioration, and items which deteriorate or fail due to exposure or ordinary wear and tear. Batteries, battery charger, onboard computer, and solid-state speed controller are covered under separate CLUB CAR warranties. Also excluded from any CLUB CAR warranty is damage to a vehicle or component resulting from a cause other than a defect including unreasonable or unintended strain or use, improper installation of accessories, installation of parts or accessories that are not original equipment, overloading, accident, alteration, abuse or neglect.

Transportation expenses for warranty services are also excluded from this warranty.

## 3. VOIDING OF WARRANTY:

THIS AND ANY OTHER WARRANTY SHALL BE VOID IF THE VEHICLE IS ABUSED OR USED IN AN UNINTENDED MANNER OR SHOWS INDICATIONS THAT IT HAS BEEN ALTERED IN ANY WAY, INCLUDING, BUT NOT LIMITED TO, MODIFICATION OF THE SPEED GOVERNOR, BRAKING SYSTEM, STEERING, TRANSAXLE, OR OTHER OPERATING SYSTEMS OF THE VEHICLE TO CAUSE IT TO PERFORM OUTSIDE CLUB CAR SPECIFICATIONS. THE WARRANTY IS LIKEWISE VOID IF THE VEHICLE INVOLVED SHOWS INDICATIONS THAT REASONABLE OR NECESSARY MAINTENANCE AS OUTLINED IN THE OWNER'S MANUAL AND MAINTENANCE AND SERVICE MANUAL WAS NOT PERFORMED AT THE TIME AND IN THE MANNER SPECIFIED IN SUCH MANUALS.

## 4. SOLE REMEDY:

CLUB CAR's liability under this limited warranty, or in any action whether based upon warranty, contract, negligence, strict product liability or otherwise, shall be the repair or replacement, at CLUB CAR's option, of the vehicle or component thereof that CLUB CAR deems to be defective. Replacement shall mean furnishing, during the applicable limited warranty period, a new vehicle or factory-reconditioned vehicle or component thereof that is identical or reasonably equivalent to the warranted product or component at no cost to the purchaser. Repair shall mean remedying a defect in the vehicle or component thereof at no cost to the purchaser during the applicable limited warranty period. If CLUB CAR elects to repair the vehicle, it may provide factory-reconditioned parts or components. All parts and components replaced under warranty shall become the property of CLUB CAR.

## **5. HOW TO MAKE A WARRANTY CLAIM:**

To make a warranty claim under this limited warranty, you must present the vehicle or defective component to an authorized CLUB CAR dealer or send the defective component, freight prepaid, to WARRANTY SERVICES, CLUB CAR, INC., 4125 Washington Road, Evans, Georgia 30809, U.S.A., 706-863-3000.

## **6. DISCLAIMER:**

**THIS LIMITED WARRANTY IS EXCLUSIVE. CLUB CAR MAKES NO OTHER WARRANTY OF ANY KIND, EXPRESSED OR IMPLIED. ANY IMPLIED WARRANTIES OF MERCHANTABILITY OR FITNESS FOR A PARTICULAR PURPOSE WHICH EXCEED THE OBLIGATIONS OR TIME LIMITS STATED IN THIS WARRANTY ARE HEREBY DISCLAIMED BY CLUB CAR AND EXCLUDED FROM THIS WARRANTY. THE PURCHASER AND CLUB CAR EXPRESSLY AGREE THAT THE REMEDY OF THE REPLACEMENT OR REPAIR OF THE DEFECTIVE VEHICLE OR COMPONENT THEREOF IS THE SOLE REMEDY OF THE PURCHASER. CLUB CAR MAKES NO OTHER REPRESENTATION OR WARRANTY OF ANY KIND, AND NO REPRESENTATIVE, EMPLOYEE, OR DEALER OF CLUB CAR HAS THE AUTHORITY TO MAKE OR IMPLY ANY REPRESENTATION, PROMISE OR AGREEMENT, WHICH IN ANY WAY VARIES THE TERMS OF THIS WARRANTY.**

## **7. NO CONSEQUENTIAL DAMAGES:**

**IN NO EVENT SHALL CLUB CAR BE LIABLE FOR ANY INCIDENTAL OR CONSEQUENTIAL DAMAGES INCLUDING, BUT NOT LIMITED TO, LOSS RELATED TO PROPERTY OTHER THAN THE VEHICLE, LOSS OF USE, LOSS OF TIME, INCONVENIENCE, OR ANY OTHER ECONOMIC LOSS.**

Some states allow neither limitation on the duration of an implied warranty nor exclusions or limitation of incidental or consequential damages. Therefore, the above limitations or exclusions may not apply to you.

This warranty gives you specific legal rights, and you may also have other rights, which vary from state to state.

## **8. INFORMATION:**

For further information contact WARRANTY SERVICES, CLUB CAR, INC., P.O. Box 204658, Augusta, Georgia 30917-4658, U.S.A., 706-863-3000.

## **9. WARNING:**

Any modification or alteration of any vehicle beyond factory specifications, including those that affect the weight distribution, stability, or speed of the vehicle, can cause serious personal injury or death.

# **CLUB CAR<sup>®</sup> LIMITED FOUR YEAR WARRANTY FOR 2006 UTILITY T-105 6-VOLT BATTERIES**

---

CLUB CAR, INC., ("CLUB CAR") hereby warrants to the original retail purchaser that the new "Trojan T-105" 6-Volt Battery installed in its new electric utility vehicle purchased from CLUB CAR or an authorized distributor or dealer will be free from defects in material and workmanship and will provide for a period of four years or 18,000 energy units whichever occurs first, subject to the terms and conditions contained herein.

This limited warranty only covers defects in material and workmanship for a period of four years or 18,000 energy units from date of purchase. The terms of this limited four year warranty shall be as follows:

Free replacement with respect to parts and labor within four years or 18,000 energy units, whichever first occurs, from date of purchase.

The battery should be returned to an authorized CLUB CAR distributor or dealer with evidence of proof of purchase date. CLUB CAR reserves the right to test and recharge any battery returned for adjustment.

## **LIMITED WARRANTY EXCLUSIONS**

THE PROVISIONS OF THIS LIMITED WARRANTY SHALL NOT APPLY TO FAILURE DUE TO:

- 1) Abuse such as overcharging, undercharging, improper fluid levels, loose wiring, or rusted or corroded hardware;
- 2) Lack of proper maintenance as outlined in the electric vehicle owner's manual;
- 3) Damages caused by improper installation of the battery;
- 4) Neglect, breakage, freezing, fire, explosion, wreckage, the addition of any chemical, or the operation of the battery in an uncharged condition (below half charge - 1,200 specific gravity);
- 5) A battery damaged by a defective charger.

Without limiting the generality of the foregoing in any way, and as part of its limited warranty exclusion, CLUB CAR does not warrant that its battery is suitable for use in any application other than in its products. As in the use of any battery, a prudent owner will read and study the charger owner's manual, the electric vehicle owner's manual, the operator instructions, and the battery warning labels; and will exercise due care in working on or around batteries.

Transportation expenses for warranty services are also excluded from this warranty.

#### **WARRANTY LIMITATIONS**

CLUB CAR's liability under this limited warranty shall be to replace a defective battery. Replacement shall be furnishing a new or used battery with sufficient life to complete the remainder of the warranty term, which is identical or reasonably equivalent to the warranted product at no cost to the purchaser during the four years or 18,000 energy units warranty period, whichever first occurs. All batteries, which are replaced under this limited warranty, become the property of CLUB CAR.

**THIS LIMITED WARRANTY IS EXCLUSIVE. CLUB CAR MAKES NO OTHER WARRANTY OF ANY KIND, EXPRESSED OR IMPLIED. ANY IMPLIED WARRANTIES OF MERCHANTABILITY OR FITNESS FOR A PARTICULAR PURPOSE WHICH EXCEED THE OBLIGATIONS OR TIME LIMITS STATED IN THIS WARRANTY ARE HEREBY DISCLAIMED BY CLUB CAR AND EXCLUDED FROM THIS WARRANTY. THE PURCHASER AND CLUB CAR EXPRESSLY AGREE THAT THE REPLACEMENT OR REPAIR OF THE DEFECTIVE VEHICLE OR COMPONENT THEREOF IS THE SOLE REMEDY OF THE PURCHASER. CLUB CAR MAKES NO OTHER REPRESENTATION OR WARRANTY OF ANY KIND AND NO REPRESENTATIVE, EMPLOYEE, DISTRIBUTOR OR DEALER OF CLUB CAR HAS THE AUTHORITY TO MAKE OR IMPLY ANY REPRESENTATION, PROMISE OR AGREEMENT, WHICH IN ANY WAY VARIES THE TERMS OF THIS WARRANTY.**

This battery is intended to be used by persons with training and experience with batteries and only in CLUB CAR electric vehicles. Any other use renders the Limited Warranties expressed herein and all implied warranties null and void and same are hereby excluded.

**ALSO EXCLUDED FROM THIS LIMITED WARRANTY ARE ANY AND ALL INCIDENTAL OR CONSEQUENTIAL DAMAGES INCLUDING, BUT NOT LIMITED TO, LOSS OF USE OR REVENUE, LOSS OF TIME, INCONVENIENCE OR ANY OTHER ECONOMIC LOSS.**

Damage not resulting from a defect in material or workmanship or that occurs due to abuse or neglect (including failure to provide reasonable and necessary maintenance), accident or alteration is excluded from this limited warranty.

Some states allow neither limitation on the duration of an implied warranty nor exclusions or limitations of incidental or consequential damages. Therefore, the above limitations or exclusions may not apply to you.

This warranty gives you specific legal rights, and you may also have other rights, which vary from states to states.

For further information contact WARRANTY SERVICES, CLUB CAR, INC., P.O. Box 204658, Augusta, Georgia, 30917-4658, U.S.A., 706-863-3000.

## **CLUB CAR<sup>®</sup> LIMITED FOUR YEAR WARRANTY FOR 2006 UTILITY T-145 6-VOLT BATTERIES**

---

CLUB CAR, INC., ("CLUB CAR") hereby warrants to the original retail purchaser that the new "Trojan T-145" 6-Volt Battery installed in its new electric utility vehicle purchased from CLUB CAR or an authorized distributor or dealer will be free from defects in material and workmanship and will provide for a period of four years or 20,000 energy units whichever occurs first, subject to the terms and conditions contained herein.

This limited warranty only covers defects in material and workmanship for a period of four years or 20,000 energy units from date of purchase. The terms of this limited four year warranty shall be as follows:

Free replacement with respect to parts and labor within four years or 20,000 energy units, whichever first occurs, from date of purchase.

The battery should be returned to an authorized CLUB CAR distributor or dealer with evidence of proof of purchase date. CLUB CAR reserves the right to test and recharge any battery returned for adjustment.

#### **LIMITED WARRANTY EXCLUSIONS**

THE PROVISIONS OF THIS LIMITED WARRANTY SHALL NOT APPLY TO FAILURE DUE TO:

- 1) Abuse such as overcharging, undercharging, improper fluid levels, loose wiring, or rusted or corroded hardware;

- 2) Lack of proper maintenance as outlined in the electric vehicle owner's manual;
- 3) Damages caused by improper installation of the battery;
- 4) Neglect, breakage, freezing, fire, explosion, wreckage, the addition of any chemical, or the operation of the battery in an uncharged condition (below half charge - 1,200 specific gravity);
- 5) A battery damaged by a defective charger.

Without limiting the generality of the foregoing in any way, and as part of its limited warranty exclusion, CLUB CAR does not warrant that its battery is suitable for use in any application other than in its products. As in the use of any battery, a prudent owner will read and study the charger owner's manual, the electric vehicle owner's manual, the operator instructions, and the battery warning labels; and will exercise due care in working on or around batteries.

Transportation expenses for warranty services are also excluded from this warranty.

#### **WARRANTY LIMITATIONS**

CLUB CAR's liability under this limited warranty shall be to replace a defective battery. Replacement shall be furnishing a new or used battery with sufficient life to complete the remainder of the warranty term, which is identical or reasonably equivalent to the warranted product at no cost to the purchaser during the four years or 20,000 energy units warranty period, whichever first occurs. All batteries, which are replaced under this limited warranty, become the property of CLUB CAR.

**THIS LIMITED WARRANTY IS EXCLUSIVE. CLUB CAR MAKES NO OTHER WARRANTY OF ANY KIND, EXPRESSED OR IMPLIED. ANY IMPLIED WARRANTIES OF MERCHANTABILITY OR FITNESS FOR A PARTICULAR PURPOSE WHICH EXCEED THE OBLIGATIONS OR TIME LIMITS STATED IN THIS WARRANTY ARE HEREBY DISCLAIMED BY CLUB CAR AND EXCLUDED FROM THIS WARRANTY. THE PURCHASER AND CLUB CAR EXPRESSLY AGREE THAT THE REPLACEMENT OR REPAIR OF THE DEFECTIVE VEHICLE OR COMPONENT THEREOF IS THE SOLE REMEDY OF THE PURCHASER. CLUB CAR MAKES NO OTHER REPRESENTATION OR WARRANTY OF ANY KIND AND NO REPRESENTATIVE, EMPLOYEE, DISTRIBUTOR OR DEALER OF CLUB CAR HAS THE AUTHORITY TO MAKE OR IMPLY ANY REPRESENTATION, PROMISE OR AGREEMENT, WHICH IN ANY WAY VARIES THE TERMS OF THIS WARRANTY.**

This battery is intended to be used by persons with training and experience with batteries and only in CLUB CAR electric vehicles. Any other use renders the Limited Warranties expressed herein and all implied warranties null and void and same are hereby excluded.

**ALSO EXCLUDED FROM THIS LIMITED WARRANTY ARE ANY AND ALL INCIDENTAL OR CONSEQUENTIAL DAMAGES INCLUDING, BUT NOT LIMITED TO, LOSS OF USE OR REVENUE, LOSS OF TIME, INCONVENIENCE OR ANY OTHER ECONOMIC LOSS.**

Damage not resulting from a defect in material or workmanship or that occurs due to abuse or neglect (including failure to provide reasonable and necessary maintenance), accident or alteration is excluded from this limited warranty.

Some states allow neither limitation on the duration of an implied warranty nor exclusions or limitations of incidental or consequential damages. Therefore, the above limitations or exclusions may not apply to you.

This warranty gives you specific legal rights, and you may also have other rights, which vary from states to states.

For further information contact WARRANTY SERVICES, CLUB CAR, INC., P.O. Box 204658, Augusta, Georgia, 30917-4658, U.S.A., 706-863-3000.

## **CLUB CAR<sup>®</sup> LIMITED FOUR YEAR WARRANTY FOR 2006 DEEP CYCLE<sup>®</sup> 12-VOLT BATTERIES**

---

CLUB CAR, INC., ("CLUB CAR") hereby warrants to the original retail purchaser that the Deep Cycle 12 volt Battery installed in its new DS electric vehicle equipped with the IQ System™ purchased from CLUB CAR or an authorized distributor or dealer will be free from defects in material and workmanship and will provide 36-hole performance (60 minute discharge capacity) for a period of four years or 800 rounds, whichever first occurs, from the date of purchase subject to the terms and conditions contained herein.

This limited warranty only covers defects in material and workmanship for a period of four years or 800 golf car rounds from date of purchase. The terms of this four-year or 800 round limited warranty shall be as follows:

Vehicles used for golf, free replacement with respect to parts and labor within four years or 800 rounds, whichever first occurs, from date of purchase.

Vehicles used for purposes other than golf, free replacement with respect to parts and labor within four years or 16,000 energy units as recorded by the Onboard Computer, whichever first occurs, from the date of purchase.

The battery should be returned to an authorized CLUB CAR distributor or dealer with evidence of proof of purchase date and number of rounds, freight prepaid. CLUB CAR reserves the right to test and recharge any battery returned for adjustment, and to verify number of rounds played by accessing information contained in the IQ System Onboard Computer.

### **LIMITED WARRANTY EXCLUSIONS**

THE PROVISIONS OF THIS LIMITED WARRANTY SHALL NOT APPLY TO FAILURE DUE TO:

- 1) Abuse such as overcharging, undercharging, improper fluid levels, loose wiring, or rusted or corroded hardware;
- 2) Lack of proper maintenance as outlined in the electric vehicle owner's manual;
- 3) Damages caused by improper installation of the battery;
- 4) Neglect, breakage, freezing, fire, explosion, wreckage, the addition of any chemical, or the operation of the battery in an uncharged condition (below half charge 1.200 specific gravity);
- 5) A battery damaged by a defective charger.

Without limiting the generality of the foregoing in any way, and as part of its limited warranty exclusion, CLUB CAR does not warrant that its PowerDrive battery is suitable for use in any application other than in its products. As in the use of any battery, a prudent owner will read and study the charger owner's manual, the electric vehicle owner's manual, the operator instructions, and the battery warning labels; and will exercise due care in working on or around batteries.

Transportation expenses for warranty services are also excluded from this warranty.

### **WARRANTY LIMITATIONS**

CLUB CAR's liability under this limited warranty shall be to replace a defective battery. Replacement shall be furnishing a new or used battery with sufficient life to complete the remainder of the warranty term, which is identical or reasonably equivalent to the warranted product at no cost to the purchaser during the four-year, 800 round or 16,000 Energy Unit limited warranty period, whichever first occurs. All batteries, which are replaced under this limited warranty, become the property of CLUB CAR.

**THIS LIMITED WARRANTY IS EXCLUSIVE. CLUB CAR MAKES NO OTHER WARRANTY OF ANY KIND, EXPRESSED OR IMPLIED. ANY IMPLIED WARRANTIES OF MERCHANTABILITY OR FITNESS FOR A PARTICULAR PURPOSE WHICH EXCEED THE OBLIGATIONS OR TIME LIMITS STATED IN THIS WARRANTY ARE HEREBY DISCLAIMED BY CLUB CAR AND EXCLUDED FROM THIS WARRANTY. THE PURCHASER AND CLUB CAR EXPRESSLY AGREE THAT THE REPLACEMENT OR REPAIR OF THE DEFECTIVE VEHICLE OR COMPONENT THEREOF IS THE SOLE REMEDY OF THE PURCHASER. CLUB CAR MAKES NO OTHER REPRESENTATION OR WARRANTY OF ANY KIND AND NO REPRESENTATIVE, EMPLOYEE, DISTRIBUTOR OR DEALER OF CLUB CAR HAS THE AUTHORITY TO MAKE OR IMPLY ANY REPRESENTATION, PROMISE OR AGREEMENT, WHICH IN ANY WAY VARIES THE TERMS OF THIS WARRANTY.**

This battery is intended to be used by persons with training and experience with batteries and only in CLUB CAR electric vehicles. Any other use renders the Limited Warranties expressed herein and all implied warranties null and void and same are hereby excluded.

**ALSO EXCLUDED FROM THIS LIMITED WARRANTY ARE ANY AND ALL INCIDENTAL OR CONSEQUENTIAL DAMAGES INCLUDING, BUT NOT LIMITED TO, LOSS OF USE OR REVENUE, LOSS OF TIME, INCONVENIENCE OR ANY OTHER ECONOMIC LOSS.**

Damage not resulting from a defect in material or workmanship or that occurs due to abuse or neglect (including failure to provide reasonable and necessary maintenance), accident or alteration is excluded from this limited warranty.

Some states allow neither limitation on the duration of an implied warranty nor exclusions or limitations of incidental or consequential damages. Therefore, the above limitations or exclusions may not apply to you.

This warranty gives you specific legal rights, and you may also have other rights, which vary from state to state.

For further information contact WARRANTY SERVICES, CLUB CAR, INC., P.O. Box 204658, Augusta, Georgia, 30917-4658, U.S.A., 706-863-3000.

# **CLUB CAR<sup>®</sup> LIMITED FOUR YEAR WARRANTY FOR 2006 POWERDRIVE<sup>®</sup> 8-VOLT BATTERIES**

---

CLUB CAR, INC., ("CLUB CAR") hereby warrants to the original retail purchaser that the new PowerDrive 8-volt Battery installed in its new electric vehicle equipped with the PowerDrive System 48™, PowerDrive Plus<sup>®</sup>, or IQ System™ purchased from CLUB CAR or an authorized distributor or dealer will be free from defects in material and workmanship and will provide 36-hole performance (60 minute discharge capacity) for a period of four years or 800 rounds, whichever first occurs, from the date of purchase subject to the terms and conditions contained herein.

This limited warranty only covers defects in material and workmanship for a period of four years or 800 golf car rounds from date of purchase. The terms of this four-year or 800 round limited warranty shall be as follows:

Vehicles used for golf, free replacement with respect to parts and labor within four years or 800 rounds, whichever first occurs, from date of purchase.

Vehicles used for purposes other than golf, free replacement with respect to parts and labor within four years or 16,000 energy units as recorded by the Onboard Computer, whichever first occurs, from the date of purchase.

The battery should be returned to an authorized CLUB CAR distributor or dealer with evidence of proof of purchase date and number of rounds, freight prepaid. CLUB CAR reserves the right to test and recharge any battery returned for adjustment, and to verify number of rounds played by accessing information contained in the PowerDrive System 48, PowerDrive Plus, or IQ System Onboard Computer.

## **LIMITED WARRANTY EXCLUSIONS**

THE PROVISIONS OF THIS LIMITED WARRANTY SHALL NOT APPLY TO FAILURE DUE TO:

- 1) Abuse such as overcharging, undercharging, improper fluid levels, loose wiring, or rusted or corroded hardware;
- 2) Lack of proper maintenance as outlined in the electric vehicle owner's manual;
- 3) Damages caused by improper installation of the battery;
- 4) Neglect, breakage, freezing, fire, explosion, wreckage, the addition of any chemical, or the operation of the battery in an uncharged condition (below half charge – 1.200 specific gravity);
- 5) A battery damaged by a defective charger.

Without limiting the generality of the foregoing in any way, and as part of its limited warranty exclusion, CLUB CAR does not warrant that its PowerDrive battery is suitable for use in any application other than in its products. As in the use of any battery, a prudent owner will read and study the charger owner's manual, the electric vehicle owner's manual, the operator instructions, and the battery warning labels; and will exercise due care in working on or around batteries.

Transportation expenses for warranty services are also excluded from this warranty.

## **WARRANTY LIMITATIONS**

CLUB CAR's liability under this limited warranty shall be to replace a defective battery. Replacement shall be furnishing a new or used battery with sufficient life to complete the remainder of the warranty term that is identical or reasonably equivalent to the warranted product at no cost to the purchaser during the four-year, 800 round or 16,000 Energy Unit limited warranty period, whichever first occurs. All batteries, which are replaced under this limited warranty, become the property of CLUB CAR.

**THIS LIMITED WARRANTY IS EXCLUSIVE. CLUB CAR MAKES NO OTHER WARRANTY OF ANY KIND, EXPRESSED OR IMPLIED. ANY IMPLIED WARRANTIES OF MERCHANTABILITY OR FITNESS FOR A PARTICULAR PURPOSE WHICH EXCEED THE OBLIGATIONS OR TIME LIMITS STATED IN THIS WARRANTY ARE HEREBY DISCLAIMED BY CLUB CAR AND EXCLUDED FROM THIS WARRANTY. THE PURCHASER AND CLUB CAR EXPRESSLY AGREE THAT THE REPLACEMENT OR REPAIR OF THE DEFECTIVE VEHICLE OR COMPONENT THEREOF IS THE SOLE REMEDY OF THE PURCHASER. CLUB CAR MAKES NO OTHER REPRESENTATION OR WARRANTY OF ANY KIND AND NO REPRESENTATIVE, EMPLOYEE, DISTRIBUTOR OR DEALER OF CLUB CAR HAS THE AUTHORITY TO MAKE OR IMPLY ANY REPRESENTATION, PROMISE OR AGREEMENT, WHICH IN ANY WAY VARIES THE TERMS OF THIS WARRANTY.**

This battery is intended to be used by persons with training and experience with batteries and only in CLUB CAR electric vehicles. Any other use renders the Limited Warranties expressed herein and all implied warranties null and void and same are hereby excluded.

**ALSO EXCLUDED FROM THIS LIMITED WARRANTY ARE ANY AND ALL INCIDENTAL OR CONSEQUENTIAL DAMAGES INCLUDING, BUT NOT LIMITED TO, LOSS OF USE OR REVENUE, LOSS OF TIME, INCONVENIENCE OR ANY OTHER ECONOMIC LOSS.**

Damage not resulting from a defect in material or workmanship or that occurs due to abuse or neglect (including failure to provide reasonable and necessary maintenance), accident or alteration is excluded from this limited warranty.

Some states allow neither limitation on the duration of an implied warranty nor exclusions or limitations of incidental or consequential damages. Therefore, the above limitations or exclusions may not apply to you.

This warranty gives you specific legal rights, and you may also have other rights, which vary from state to state.

For further information contact WARRANTY SERVICES, CLUB CAR, INC., P.O. Box 204658, Augusta, Georgia, 30917-4658, U.S.A., 706-863-3000.

---

## **CLUB CAR<sup>®</sup> LIMITED FOUR YEAR WARRANTY FOR 2006 POWERDRIVE<sup>®</sup> BATTERY CHARGERS**

---

CLUB CAR, INC., ("CLUB CAR") hereby warrants to the original retail purchaser that its new PowerDrive Chargers purchased from CLUB CAR or an authorized distributor or dealer will be free from defects in material and workmanship under normal use and service for a period of four years from the date of purchase, subject to the terms, provisions, limitations, and exclusions contained herein.

The limited warranty with respect to parts and labor only covers defects in material and workmanship for a period of four years from the date of purchase. Such repair labor shall be performed only by CLUB CAR or by an authorized distributor or dealer. Purchaser shall be responsible for all freight costs to and from CLUB CAR's facility.

### **LIMITED WARRANTY EXCLUSIONS**

THE PROVISIONS OF THIS LIMITED WARRANTY SHALL NOT APPLY TO FAILURE DUE TO:

- 1) Lack of normal maintenance services such as preventive maintenance checks and tightening loose wire connections;
- 2) Semiconductor parts such as diodes and fuses which are vulnerable to electrical overloads (including lightning) beyond the control of CLUB CAR;
- 3) Charger DC cord set with plug, which is a wear item and subject to user abuse.

Any warranty service, which includes labor during the first year, must be performed by CLUB CAR or by an authorized distributor or dealer. For repairs made by qualified technicians other than CLUB CAR's factory technicians or an authorized distributor or dealer, CLUB CAR will provide only the replacement parts or components.

The PowerDrive Chargers are intended to be used by persons with knowledge of the chargers and proper charging practices and only on CLUB CAR PowerDrive System 48™, PowerDrive Plus<sup>®</sup>, and IQ System™ vehicles. Any other use renders the Limited Warranties expressed herein and any implied warranties null and void and same are hereby excluded.

Without limiting the generality of the foregoing in any way, and as part of its limited warranty exclusion, CLUB CAR does not warrant that the PowerDrive Charger is suitable for use in any application other than its PowerDrive System 48, PowerDrive Plus, and IQ System products. As in the use of any electrical device, a prudent owner will read and study the charger owner's manual, the electric vehicle owner's manual, the operator instructions, and the battery warning labels; and will exercise due care in working on or around electrical devices.

Transportation expenses for warranty services are also excluded from this warranty.

### **WARRANTY LIMITATIONS**

CLUB CAR's liability under this limited warranty, or in any action whether based upon warranty, contract, negligence, strict product liability or otherwise, shall be the replacement or repair of a charger or component thereof that CLUB CAR deems to be defective. Replacement shall mean furnishing, during the applicable limited warranty period, a new charger or component thereof that is identical or reasonably equivalent to the warranted product or defective component at no cost to the purchaser. Repair shall mean remedying a defect in the charger or component thereof at no cost to the purchaser during the applicable limited warranty period. If CLUB CAR elects to repair the charger, it may provide factory-reconditioned parts or components. All parts and components replaced under warranty shall become the property of CLUB CAR.

**THIS LIMITED WARRANTY IS EXCLUSIVE. CLUB CAR MAKES NO OTHER WARRANTY OF ANY KIND, EXPRESSED OR IMPLIED. ANY IMPLIED WARRANTIES OF MERCHANTABILITY OR FITNESS FOR A PARTICULAR PURPOSE WHICH EXCEED THE OBLIGATIONS OR TIME LIMITS STATED IN THIS WARRANTY ARE HEREBY**

**DISCLAIMED BY CLUB CAR AND EXCLUDED FROM THIS WARRANTY. THE PURCHASER AND CLUB CAR EXPRESSLY AGREE THAT THE REPLACEMENT OR REPAIR OF THE DEFECTIVE VEHICLE OR COMPONENT THEREOF IS THE SOLE REMEDY OF THE PURCHASER. CLUB CAR MAKES NO OTHER REPRESENTATION OR WARRANTY OF ANY KIND AND NO REPRESENTATIVE, EMPLOYEE, DISTRIBUTOR OR DEALER OF CLUB CAR HAS THE AUTHORITY TO MAKE OR IMPLY ANY REPRESENTATION, PROMISE OR AGREEMENT, WHICH IN ANY WAY VARIES THE TERMS OF THIS WARRANTY.**

**IN NO EVENT SHALL CLUB CAR BE LIABLE FOR ANY INCIDENTAL OR CONSEQUENTIAL DAMAGES INCLUDING, BUT NOT LIMITED TO, LOSS RELATED TO PROPERTY OTHER THAN THE BATTERY CHARGER, LOSS OF USE, LOSS OF TIME, INCONVENIENCE, OR ANY OTHER ECONOMIC LOSS.**

Damage not resulting from a defect that occurs due to unreasonable use, abuse or neglect (including failure to provide reasonable or necessary maintenance), accident or alteration is excluded from the limited warranty.

Some states allow neither limitation on the duration of an implied warranty nor exclusions or limitations of incidental or consequential damages. Therefore, the above limitations or exclusions may not apply to you.

This warranty gives you specific legal rights, and you may also have other rights, which vary from state to state.

For further information contact WARRANTY SERVICES, CLUB CAR, INC., P.O. Box 204658, Augusta, Georgia 30917-4658, U.S.A., 706-863-3000.

## **CLUB CAR<sup>®</sup> LIMITED FOUR YEAR WARRANTY FOR 2006 ONBOARD COMPUTERS AND SOLID STATE SPEED CONTROLLERS**

---

CLUB CAR, INC., ("CLUB CAR") hereby warrants to the original retail purchaser that the new Onboard Computer and the Solid State Speed Controller, hereinafter called "Computer" and "Controller" respectively, installed in its new electric vehicle equipped with the PowerDrive<sup>®</sup> System 48™, PowerDrive Plus<sup>®</sup>, or IQ System™ purchased from CLUB CAR or an authorized distributor or dealer will be free from defects in material and workmanship for a period of four years or 800 rounds, whichever first occurs, from the date of purchase subject to the terms and conditions contained herein.

This limited warranty only covers defects in material and workmanship for a period of four years or 800 golf car rounds from date of purchase. The terms of this four-year or 800 round limited warranty shall be as follows:

Vehicles used for golf, free replacement with respect to parts and labor within four years or 800 rounds, whichever first occurs, from date of purchase.

Vehicles used for purposes other than golf, free replacement with respect to parts and labor within four years or 16,000 energy units as recorded by the Computer, whichever first occurs, from date of purchase.

The Computer or Controller should be returned to an authorized CLUB CAR distributor or dealer with evidence of proof of purchase date and number of rounds, freight prepaid. CLUB CAR reserves the right to test any Computer returned for warranty and to verify number of rounds played by accessing information contained in the Computer.

### **LIMITED WARRANTY EXCLUSIONS**

THE PROVISIONS OF THIS LIMITED WARRANTY SHALL NOT APPLY TO FAILURE DUE TO:

- 1) Abuse or neglect, such as improper battery fluid levels, loose wiring, or rusted or corroded hardware;
- 2) Lack of proper maintenance as outlined in the electric vehicle owner's manual;
- 3) Damages caused by improper installation of the Computer or Controller;
- 4) Vehicles charged by systems other than the CLUB CAR PowerDrive Charger.

Without limiting the generality of the foregoing in any way, and as part of its limited warranty exclusion, CLUB CAR does not warrant that the Computer or Controller is suitable for use in any application other than its PowerDrive System 48, PowerDrive Plus, and IQ System products. As in the use of any battery operated device, a prudent owner will read and study the charger owner's manual, the electric vehicle owner's manual, the operator instructions, and the battery warning labels; and will exercise due care in working on or around batteries.

Transportation expenses for warranty services are also excluded from this warranty.

### **WARRANTY LIMITATIONS:**

CLUB CAR's liability under this limited warranty shall be to replace a defective Computer or Controller. Replacement shall be furnishing a new or reconditioned Computer or Controller that is identical or reasonably equivalent to the warranted

product at no cost to the purchaser during the four-year or 800 round limited warranty period for golf use or 4 years or 16,000 energy units for use other than golf, whichever first occurs, except for transportation expenses. All parts and components replaced under this limited warranty become the property of CLUB CAR.

**THIS LIMITED WARRANTY IS EXCLUSIVE. CLUB CAR MAKES NO OTHER WARRANTY OF ANY KIND, EXPRESSED OR IMPLIED. ANY IMPLIED WARRANTIES OF MERCHANTABILITY OR FITNESS FOR A PARTICULAR PURPOSE WHICH EXCEED THE OBLIGATIONS OR TIME LIMITS STATED IN THIS WARRANTY ARE HEREBY DISCLAIMED BY CLUB CAR AND EXCLUDED FROM THIS WARRANTY. THE PURCHASER AND CLUB CAR EXPRESSLY AGREE THAT THE REPLACEMENT OR REPAIR OF THE DEFECTIVE VEHICLE OR COMPONENT THEREOF IS THE SOLE REMEDY OF THE PURCHASER. CLUB CAR MAKES NO OTHER REPRESENTATION OR WARRANTY OF ANY KIND AND NO REPRESENTATIVE, EMPLOYEE, DISTRIBUTOR OR DEALER OF CLUB CAR HAS THE AUTHORITY TO MAKE OR IMPLY ANY REPRESENTATION, PROMISE OR AGREEMENT, WHICH IN ANY WAY VARIES THE TERMS OF THIS WARRANTY.**

This computer or controller is intended to be used only in CLUB CAR PowerDrive System 48, PowerDrive Plus, and IQ System electric vehicles. Any other use renders the Limited Warranties expressed herein and all implied warranties null and void and same are hereby excluded.

**ALSO EXCLUDED FROM THIS LIMITED WARRANTY ARE ANY AND ALL INCIDENTAL OR CONSEQUENTIAL DAMAGES INCLUDING, BUT NOT LIMITED TO, LOSS OF USE OR REVENUE, LOSS OF TIME, INCONVENIENCE OR ANY OTHER ECONOMIC LOSS.**

Damage not resulting from a defect in material or workmanship or that occurs due to abuse or neglect (including failure to provide reasonable and necessary maintenance), accident or alteration is excluded from this limited warranty.

Some states allow neither limitation on the duration of an implied warranty nor exclusions or limitations of incidental or consequential damages. Therefore, the above limitations or exclusions may not apply to you.

This warranty gives you specific legal rights, and you may also have other rights, which vary from state to state.

For further information contact WARRANTY SERVICES, CLUB CAR, INC., P.O. Box 204658, Augusta, Georgia, 30917-4658, U.S.A., 706-863-3000.

# CALIFORNIA EMISSION CONTROL WARRANTY STATEMENT

Your new Club Car, Inc. ("CLUB CAR") vehicle engine complies with both the U.S. EPA and State of California emission regulations.

## YOUR WARRANTY RIGHTS AND OBLIGATIONS:

The California Air Resources Board ("CARB") and CLUB CAR are pleased to explain the emission control system warranty on your 2006 vehicle engine. In California, new small off-road engines (SORE) must be designed, built and equipped to meet the State's stringent anti-smog standards. CLUB CAR must warrant the emission control system on the vehicle engine for the periods of time listed below provided there has been no abuse, neglect or improper maintenance of your small off-road engine.

Your emission control system may include parts such as the carburetor or fuel-injection system, the ignition system, and catalytic converter. Also included may be hoses, belts, connectors and other emission-related assemblies.

Where a warrantable condition exists, CLUB CAR will repair your vehicle engine at no cost to you including diagnosis, parts and labor.

## MANUFACTURER'S WARRANTY COVERAGE:

This emission control system is warranted for two years. If any emission-related part on your equipment is defective, the part will be repaired or replaced by CLUB CAR.

## OWNER'S WARRANTY RESPONSIBILITIES:

- As the vehicle engine owner, you are responsible for the performance of the required maintenance listed in your owner's manual. CLUB CAR recommends that you retain all receipts covering maintenance on your vehicle engine, but CLUB CAR cannot deny warranty solely for the lack of receipts or for your failure to ensure the performance of all scheduled maintenance.

- As the vehicle engine owner, you should however be aware that CLUB CAR may deny you warranty coverage if vehicle engine or a part has failed due to abuse, neglect, improper maintenance or unapproved modifications.

- You are responsible for presenting vehicle engine to a CLUB CAR distribution center as soon as a problem exists. The warranty repairs should be completed in a reasonable amount of time, not to exceed 30 days.

If you have any questions regarding your warranty rights and responsibilities, you should contact WARRANTY SERVICES, CLUB CAR, INC., P.O. Box 204658, Augusta, Georgia 309017-4658, U.S.A., 1-706-863-3000.

## CLUB CAR EXPLANATION OF EMISSION CONTROL WARRANTY:

### 1. WARRANTY:

CLUB CAR warrants to the ultimate purchaser and each subsequent purchaser that the SORE or equipment is designed, built and equipped so as to conform with all applicable regulations; and free from defects in materials and workmanship that cause the failure of a warranted part to be identical in all material respects to that part as described in CLUB CAR's application for certification. The warranty period begins on the date the engine or equipment is delivered to an ultimate purchaser or first placed into service. The warranty period is two years.

### 2. COVERAGE:

Subject to certain conditions and exclusions as stated below, the warranty on emission-related parts is as follows:

(1) Any warranted part that is not scheduled for replacement as required maintenance in the written instructions supplied, is warranted for the warranty period stated above. If the part fails during the period of warranty coverage, the part will be repaired or replaced by CLUB CAR according to subsection (4) below. Any such part repaired or replaced under warranty will be warranted for the remainder of the period.

(2) Any warranted part that is scheduled only for regular inspection in the written instructions supplied is warranted for the warranty period stated above. Any such part repaired or replaced under warranty will be warranted for the remaining warranty period.

(3) Any warranted part that is scheduled for replacement as required maintenance in the written instructions supplied is warranted for the period of time before the first scheduled replacement date for that part. If the part fails before the first scheduled replacement, the part will be repaired or replaced by CLUB CAR according to subsection (4) below. Any such part repaired or replaced under warranty will be warranted for the remainder of the period prior to the first scheduled replacement point for the part.

(4) Repair or replacement of any warranted part under the warranty provisions herein must be performed at a warranty station\* at no charge to the owner.

(5) Notwithstanding the provisions herein, warranty services or repairs will be provided at all of our distribution centers that are franchised to service the subject engines or equipment.

(6) The engine or equipment owner will not be charged for diagnostic labor that is directly associated with diagnosis of a defective, emission-related warranted part, provided that such diagnostic work is performed at a warranty station\*.

(7) CLUB CAR is liable for damages to other engine or equipment components proximately caused by a failure under warranty of any warranted part.

(8) Throughout the engine or equipment warranty period stated above, CLUB CAR will maintain a supply of warranted parts sufficient to meet the expected demand for such parts.

(9) Any replacement part may be used in the performance of any warranty maintenance or repairs and must be provided without charge to the owner. Such use will not reduce the warranty obligations of CLUB CAR.

(10) Add-on or modified parts that are not exempted by the Air Resources Board may not be used. The use of any non-exempted add-on or modified parts by the ultimate purchaser will be grounds for disallowing a warranty claim. CLUB CAR will not be liable to warrant failures of warranted parts caused by the use of a non-exempted add-on or modified part.

\*CLUB CAR, its authorized dealers, or a service agency approved by CLUB CAR.

### ITEMS COVERED BY THIS WARRANTY:

The repair or replacement of any warranted part otherwise eligible for warranty coverage may be excluded from such warranty coverage if CLUB CAR demonstrates that the engine or equipment has been abused, neglected, or improperly maintained, and that such abuse, neglect, or improper maintenance was the direct cause of the need for repair or replacement of the part. That notwithstanding, any adjustment of a component that has a factory installed, and properly operating, adjustment limiting device is still eligible for warranty coverage. The following emission warranty parts list are covered:

#### SYSTEMS COVERED

Fuel Metering

Exhaust

Air Induction

Ignition

Positive Crankcase Ventilation (PCV) System

Misc. Parts

Emission-related parts will vary between vehicles; therefore, certain vehicles may not include all of the listed parts or may include equivalent parts.

#### PARTS DESCRIPTION

Carburetor assembly, fuel injection pump, fuel injection nozzle, fuel regulator

Catalyst

Air filter housing, air filter\*, crankcase breather tube

Flywheel magneto, ignition pulse generator, ignition coil assembly, ignition control module, spark plug cap, spark plug\*

PCV valve, oil filler cap

Belts, fuel hose, hosing, tubing, fittings, seals, gasket, and clamps associated with the above systems

### 3. EXCLUSIONS:

Excluded from this warranty is damage to a vehicle or component resulting from a cause other than a defect including unreasonable or unintended strain or use, improper installation of accessories, installation of parts or accessories that are not original equipment, overloading, accident, alteration, abuse or neglect. This warranty covers only those failures resulting from defects in material or workmanship.

Transportation expenses for warranty services are also excluded from this warranty.

### 4. VOIDING OF WARRANTY:

THIS AND ANY OTHER WARRANTY SHALL BE VOID IF THE VEHICLE IS ABUSED OR USED IN AN UNINTENDED MANNER OR SHOWS INDICATIONS THAT IT HAS BEEN ALTERED IN ANY WAY, INCLUDING, BUT NOT LIMITED TO, MODIFICATION OF THE SPEED GOVERNOR, BRAKING SYSTEM, STEERING, TRANSAXLE, OR OTHER OPERATING SYSTEMS OF THE VEHICLE TO CAUSE IT TO PERFORM OUTSIDE CLUB CAR SPECIFICATIONS. THE WARRANTY IS LIKEWISE VOID IF THE VEHICLE INVOLVED SHOWS INDICATIONS THAT REASONABLE OR NECESSARY MAINTENANCE AS OUTLINED IN THE OWNERS MANUAL AND MAINTENANCE AND SERVICE MANUAL WAS NOT PERFORMED AT THE TIME AND IN THE MANNER SPECIFIED IN SUCH MANUALS.

### 5. NO CONSEQUENTIAL DAMAGES:

In no event shall Club Car be liable for any incidental or consequential damages including, but not limited to, loss related to property other than the vehicle, loss of use, loss of time, inconvenience, or any other economic loss. This warranty is applicable only where the California or U.S. EPA emission control system warranty regulation is in effect.

### 6. HOW TO MAKE A WARRANTY CLAIM:

To make a warranty claim under this limited warranty, you must present the vehicle or defective component to an authorized CLUB CAR dealer or send the defective component, freight prepaid, to WARRANTY SERVICES, CLUB CAR, INC., 4125 Washington Road, Evans, Georgia 30809, U.S.A., 706-863-3000.

IF THE WARRANTY REGISTRATION FORM IS NOT COMPLETED AND RETURNED TO CLUB CAR AT THE TIME OF THE ORIGINAL RETAIL SALE, PURCHASER MUST PROVIDE PROOF OF DATE OF PURCHASE WITH ANY WARRANTY CLAIM.

# EMISSION CONTROL INFORMATION

## Fuel Information

THIS VEHICLE IS CERTIFIED TO OPERATE ON UNLEADED REGULAR GRADE GASOLINE ONLY. A minimum of 87 octane of the anti-knock index is recommended. The anti-knock index is posted on service station pumps in the U.S.A.

## Emission Control Information

To protect the environment in which we all live, Club Car has incorporated crankcase emission (1) and exhaust emission (2) control systems (EM) in compliance with applicable regulations of the U.S. Environmental Protection Agency and California Air Resources Board.

### 1. Crankcase Emission Control System

A sealed-type crankcase emission control system is used to eliminate blow-by gases. The blow-by gases are led to the breather chamber through the crankcase. Then, it is led to the air cleaner.

Oil is separated from the gases while passing through the inside of the breather chamber from the crankcase, and then returned back to the bottom of the crankcase.

### 2. Exhaust Emission Control System

The exhaust emission control system applied to this engine consists of a carburetor and an ignition system having optimum ignition timing characteristics.

The carburetors have been calibrated to provide lean air/fuel mixture characteristics and optimum fuel economy with a suitable air cleaner and exhaust system.

### Maintenance and Warranty

Proper maintenance is necessary to ensure that your engine will continue to have low emission levels. Those items identified by the Periodic Maintenance Chart are necessary to ensure compliance with the applicable standards.

The Club Car Limited Emission Control System Warranty requires that you return your engine to an authorized Club Car Dealer for remedy under warranty. Please read the warranty carefully, and keep it valid by complying with the owner's obligations it contains.

### Tampering with Emission Control System Prohibited

California State law prohibits the following

acts or the causing thereof: (1) the removal or rendering inoperative by any person other than for purposes of maintenance, repair, or replacement, of any device or element of design incorporated into any new engine for the purposes of emission control prior to its sale or delivery to the ultimate purchaser or while it is in use, or (2) the use of the engine after such device or element of design has been removed or rendered inoperative by any person.

Among those acts presumed to constitute tampering are the acts listed below:

Do not tamper with the original emission related parts:

- Carburetor and internal parts
- Spark plugs
- Magneto or electronic ignition system
- Fuel filter element
- Air cleaner element
- Crankcase
- Cylinder head
- Breather chamber and internal parts
- Intake pipe and tube

# FUEL AND OIL RECOMMENDATIONS

## Fuel

Use only clean, fresh, unleaded regular grade gasoline.

### Octane Rating

The octane rating of a gasoline is a measure of its resistance to "knocking". Use of a minimum of 87 octane of the anti-knock index is recommended. The anti-knock index is posted on service station pumps in the U.S.A.

### NOTE

- If "knocking or pinging" occurs, use a different brand of gasoline or higher octane rating.

## CAUTION

- Do not mix oil with gasoline.

## Oxygenated Fuel

If you use oxygenated fuel (either ethanol or MTBE added to gasoline), be sure it is unleaded and meets the minimum octane rating requirement.

The following are the EPA approved percentages of fuel oxygenates.

**ETHANOL:** (Ethyl or Grain Alcohol) You may use gasoline containing up to 10% ethanol by volume.

**MTBE:** (Methyl Tertiary Butyl Ether) You may use gasoline containing up to 15% MTBE by volume.

**METHANOL:** (Methanol or Wood Alcohol) 5% by volume.

You may use gasoline containing up to 5% methanol by volume, as long as it also contains cosolvents and corrosion inhibitors to protect the fuel system. Gasoline containing more than 5% methanol by volume may cause starting and/or performance problems. It may also damage metal, rubber, and plastic parts of your fuel system.

## WARNING

- Gasoline is extremely flammable and can be explosive under certain conditions. Turn the engine switch OFF. Do not smoke. Make sure the area is well ventilated and free from any source of flame or sparks; this includes any appliance with a pilot light. Never fill the tank so the fuel level rises into the filler neck. If the tank is overfilled, heat may cause the fuel to expand and overflow through the vent in the fuel tank.

## Engine Oil

The following engine oils are recommended. API Service Classification: SC, SD, SE, SF, SG, or SH.

## WARNING

- After refueling, make sure the tank cap is closed securely.
- If gasoline is spilled on the fuel tank wipe it off immediately.

## Oil Viscosity

Choose the viscosity according to the temperature as follows:

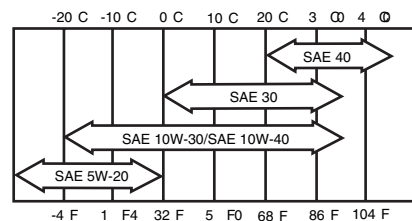

### NOTE

- Using multi-grade oils (5W-20, 10W-30, and 10W-40) will increase oil consumption. Check oil level more frequently when using them.









Publication Part Number 102907505  
Edition Code 0705C1205B



**Club Car, Inc.**  
P.O. Box 204658  
Augusta, GA 30917-4658  
USA

<b>Web</b>	www.clubcar.com
<b>Phone</b>	1.706.863.3000
	1.800.ClubCar
<b>Int'l'l</b>	+1 706.863.3000
<b>Fax</b>	1.706.863-5808