



2008  
DS Gold Standard  
Vehicles  
Electric

Owner's Manual

Golf Car  
Handyman  
4-Passenger  
Lynx Box Bed  
Lynx 4-Passenger





## NOTICE

---

Warranty information appears at the end of this manual. No other warranties, expressed or implied, are contained herein. Your authorized representative checked the vehicle before it was delivered to you and will provide you a copy of the completed vehicle warranty registration form.

Club Car is not liable for errors in this manual or for incidental or consequential damages that result from the use of the material in this manual.

Golf cars covered in this manual conform to the current American National Standards Institute's Z130 Safety and Performance Requirements for Golf Cars. This standard, which promotes safety in the design, application, and operation of golf cars, defines a golf car as "a vehicle used to convey a person or persons and equipment to play the game of golf in an area designated as a golf course." Throughout this manual, the words "golf car" are used in reference to golf cars only. The word "vehicle" is used in reference to any other vehicles covered in this manual, or may be used when referring to all vehicles, including golf cars, categorically.

This manual contains proprietary information that is protected by copyright. All rights are reserved. No part of this manual may be photocopied, reproduced, or translated to another language without the written consent of Club Car, Inc.

The information contained in this document is subject to change without notice.

Club Car reserves the right to make design changes to vehicles without obligation to make these changes on units previously sold.

These vehicles do not conform to Federal Motor Vehicle Safety Standards for automobiles or to FMVSS 500 for low-speed vehicles, and are not equipped for operation on public streets, roads, or highways.



**P. O. Box 204658  
Augusta, Georgia 30917-4658 USA  
Telephone 706-863-3000  
Service Parts Fax 706-855-7413  
www.clubcar.com**

Copyright © 2007 Club Car, Inc.  
*Club Car, Carryall, Intellitrak, and Precedent* are  
registered trademarks of Club Car, Inc.  
This manual effective August 1, 2007.

## FOREWORD

---

Thank you for choosing Club Car, the name most widely recognized as the industry leader in vehicle efficiency and long-lasting value. You have chosen the finest vehicle on the market. Please protect your investment and ensure that your Club Car vehicle(s) provides years of reliable, superior performance by reading and following the maintenance instructions in this manual.

Your comfort and safety are important to us, so we urge you to read and follow the step-by-step operating instructions and safety procedures in this manual. These instructions must be followed in order to avoid the risk of severe personal injury. If you rent or loan your vehicle to others, we recommend that you ask them to read this manual before they operate the vehicle.

Club Car products are backed by a customer support system designed to offer you fast, courteous service. In the event that your Club Car vehicle needs repairs or service, we recommend that your local authorized Club Car representative perform them. For the name and address of the Club Car representative nearest you, logon to our web site at [www.clubcar.com](http://www.clubcar.com) or call 1-800-ClubCar (258-2227). If you would prefer to write to us, direct your letter to: Club Car, Attention: Marketing Services, P.O. Box 204658, Augusta, Georgia 30917-4658 USA. Your local authorized Club Car representative can also provide technical advice, parts, and service manuals.

We hope you will consider this owner's manual a permanent part of your Club Car vehicle. If you sell the vehicle, please include the manual so that the next owner will have the important operating, safety, and maintenance information it contains.

## TABLE OF CONTENTS

---

Safety Decal and Feature Identification .....	4
Practice Safety .....	7
Proposition 65 – State of California .....	7
Safety Details .....	8
General Warnings .....	8
General Information .....	10
Model Identification .....	10
Controls and Indicators .....	11
Pre-Operation and Daily Safety Checklist .....	16
Performance Inspection .....	16
Driving Instructions .....	17
Loading and Unloading – Box Bed Vehicles .....	19
Towing with the Vehicle – Golf Car and Handyman Vehicles .....	20
Towing the Vehicle .....	21
Transporting on a Trailer .....	22
Storage .....	22
Maintenance .....	23
Periodic Service Schedule .....	24
Periodic Lubrication Schedule .....	26
Vehicle Controller .....	28
Batteries .....	28
Battery Charger .....	30
Cleaning the Vehicle .....	33
Accessories .....	34
Subsequent Owner Registration .....	34
Specifications – Golf Car, 4-Passenger, and Handyman .....	35
Specifications – Lynx 4-passenger and Box Bed Vehicle .....	36

## **SAFETY DECAL AND FEATURE IDENTIFICATION**

---

The following pages contain safety decal and feature identification information. For detailed information on specific features, read the appropriate section in this manual.

# ELECTRIC VEHICLE

**WARNING**

**ROLLOVER OR FALLING OFF MAY CAUSE DEATH.**

- Before using vehicle, read operating instructions.
- Remain seated and hold on to seat handle while moving.
- Do not start vehicle until all occupants are seated.
- Two (2) persons per seat maximum.
- Operate from driver side only and not on public roads.
- Keep entire body inside vehicle while moving.
- Drive slowly in turns and straight up and down slopes.
- Do not leave children unattended on vehicle.
- Never operate under the influence of alcohol or drugs.
- Use brakes to reduce speed when coasting downhill.
- Never stand in front of or behind vehicle.

CCI 101960601

**UNDER 16**

**WARNING**

**YOUNG DRIVERS INCREASE CHANCE OF DEATH**

- Young drivers may not be able to control vehicle.
- No drivers younger than 16 years old.

CCI 102075801

**OPERATING INSTRUCTIONS**

- Read owner's manual and dash-mounted safety warnings prior to driving.
- Study and understand controls.

TO OPERATE

- Turn wheels to desired direction and ensure path is clear.
- Turn key to ON position.
- While stopped, place Forward/Reverse switch in desired position:  
F—Forward N—Neutral R—Reverse (Buzzer will sound)
- Park brake will release and vehicle will start moving when accelerator pedal is pressed.
- Slowly press accelerator pedal to increase speed.
- To stop, release accelerator pedal and press brake pedal.

BEFORE LEAVING

- Press park brake pedal until it locks and holds vehicle.
- Place Forward/Reverse switch in NEUTRAL position.
- Turn key OFF and remove key when not in use.

MOTOR BRAKING

- Electric motor braking provides speed regulation functions.
- For parked vehicle, beeping alarm indicates vehicle roll away.
- In operation, beeping alarm indicates reduction in motor braking.
- Apply brakes to further reduce vehicle speed as required.
- System is activated only when tow switch is in the TOW position.
- When towing this vehicle, tow switch must be in the TOW position.

CCI 102519201

**IMPORTANT NOTICE**

This vehicle does not conform to ANSI Z130.1 - "Standard for Golf Cars - Safety and Performance Requirements" because it is capable of speeds in excess of 15 miles per hour. Exercise caution.

CCI 102228701

**IMPORTANT NOTICE**

- Maximum vehicle speed is limited by motor braking during downhill operation with accelerator pedal depressed.
- If motor brake enabled, vehicle motor will brake when accelerator pedal is released.
- Beeping alarm indicates reduction in motor braking. Apply brakes to reduce speed.
- System is activated only when tow switch is in the "RUN" position.

101959902

**VEHICLE LOADING**

Read Owner's Manual and warnings on dash.

- Vehicle rated capacity - 550 lbs. on level surface only. Weight to include passengers, cargo bed load, and gross trailer weight. See Owner's Manual.
- Maximum cargo load - 150 lbs. Weight to include cargo bed load and gross trailer weight.
- Maximum trailer hitch tongue weight - 150 lbs.

- Cargo should be evenly spread over the floor of the cargo bed as far forward as possible and secured.
- For vehicle stability, when fully loaded, drive slowly and avoid stopping on or backing down steep hills.
- Avoid top heavy loads. See Owner's Manual.
- When driving on uneven terrain or down steep hills, reduce speed and load.

SVP147801

275

1	101825101	Decal, On/Off Key Switch (above key switch)	11		Brake Pedal
2	101959902	Decal, Motor Braking Notice (below instrument panel)	12		Park Brake Pedal
3	101960601	Decal, Rollover Warning (on instrument panel)	13		
4	102075801	Decal, Young Driver Warning (below instrument panel)	14		
5	102228701	Decal, Private Speed Notice (below instrument panel) (with private speed option)	15		
6	102519201	Decal, Operating Instructions (on steering wheel)	16		
7	SVP147801	Decal, Vehicle Loading Instructions (below instrument panel) (Handyman and Lynx box bed vehicles)	17		
8		Battery Warning Light	18		
9		Serial Number	19		
10		Accelerator Pedal	20		

2008 DS Electric Gold Standard Vehicle Owner's Manual

Page 5

Downloaded from [www.Manualslib.com](http://www.Manualslib.com) manuals search engine

**ELECTRIC VEHICLE**

**NOTICE**  
Do not operate vehicle without this cover properly installed. Do not direct water stream in this area; will cause damage to components. See vehicle maintenance and service manual before servicing. CCI 101931501

**WARNING** TOW RUN  
Place Tow/Run switch in TOW position before:  
• Disconnecting or connecting batteries  
• Towing  
• Extended storage  
• Servicing  
FAILURE TO HEED THIS WARNING COULD RESULT IN A BATTERY EXPLOSION OR SEVERE PERSONAL INJURY. CCI 101908601

**WARNING**  
Riding in cargo bed can cause severe injury or death. Do not ride in cargo bed. CCI 101533901

**WARNING**  
FALLING OFF COULD RESULT IN SEVERE INJURY OR DEATH  
• Remain seated with entire body inside vehicle and hold on to seat handle or handrail at all times.  
• Two (2) persons per bench seat maximum.  
• One (1) person per bucket seat maximum.  
• Do not leave children unattended on vehicle at anytime.  
• Never stand in front of or behind vehicle. CCI 101705701

**NOTICE**  
• DO NOT OPERATE VEHICLE WITHOUT COVER IN PLACE.  
• DO NOT DIRECT WATER STREAM AT THIS SWITCH. CCI 1016109-01

276

1	101553901	Decal, Bed Loading Warning (on cargo bed) (Handyman and Lynx box bed vehicles)	11		
2	101610901	Decal, Wiper Switch Cover Notice (on wiper switch cover) (Wiper switch vehicles)	12		
3	101705701	Decal, Falling Off Warning (on rear-facing hand rail (4-passenger vehicles)	13		
4	101908601	Decal, Tow Switch Warning (on Tow/Run switch plate, under seat)	14		
5	101931501	Decal, Component Cover Notice (on electrical component cover)	15		
6		Forward/Reverse Control	16		
7		Forward/Reverse Control	17		
8			18		
9			19		
10			20		

---

**PRACTICE SAFETY**

---

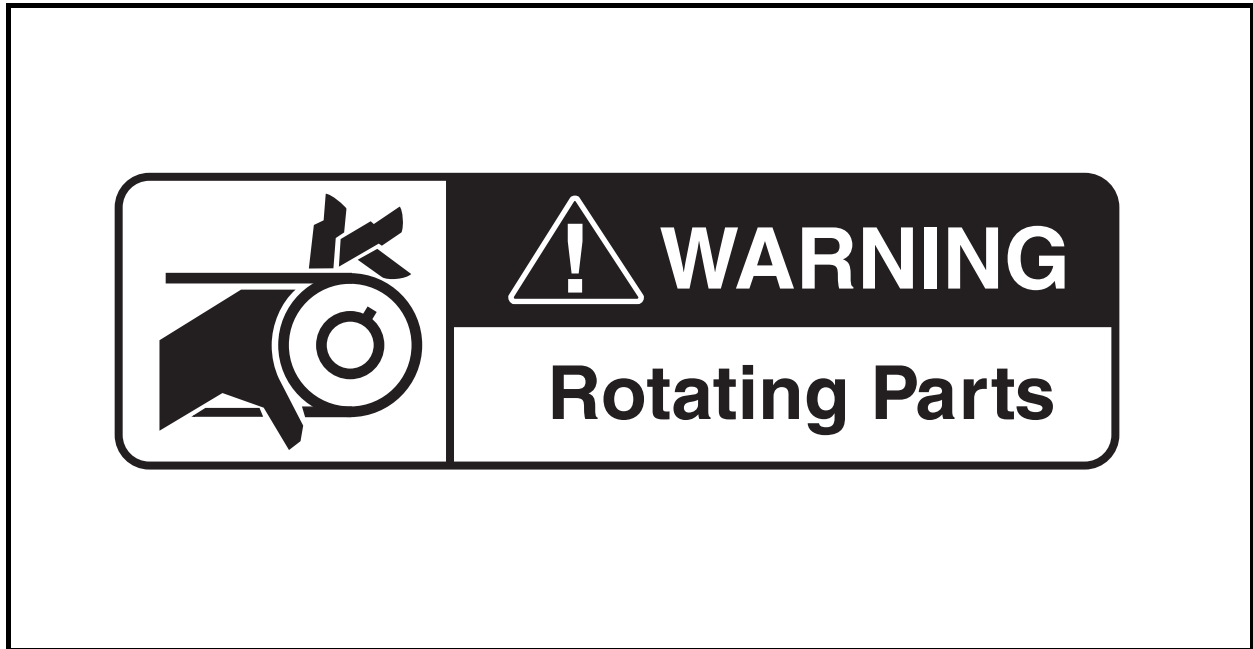

Figure 1 Practice Safety

Safety signs like you see above may at first seem shocking, but their impact is mild compared with the reality of severe personal injury.

Your safety and satisfaction are of the utmost importance to us. That is why before operating the vehicle, we urge you to review the information in this manual. Understand and become familiar with the DANGER, WARNING, and CAUTION statements and procedures it contains, along with the safety decals that are affixed to your vehicle.

Take time to understand the language of safety. It is a language that can save your life.

---

**PROPOSITION 65 – STATE OF CALIFORNIA**

---

** WARNING**

- This product contains or emits chemicals or substances that have been determined by the state of California to cause cancer and birth defects or other reproductive harm.

---

## SAFETY DETAILS

---

### **WARNING**

- This owner's manual should be read completely before attempting to drive or service the vehicle. Failure to follow the instructions in this manual could result in property damage, severe personal injury, or death.

It is important to note that some vital statements throughout this manual and on the decals affixed to the vehicle are preceded by the words DANGER, WARNING, or CAUTION. For your protection, we recommend that you take special notice of these safety precautions. Safety precautions are essential and must be followed.

Throughout this manual and on the operation and safety decals affixed to the vehicle, the words "golf car" are used in reference to golf cars only. The word "vehicle" is used in reference to any other vehicles covered in this manual, or may be used when referring to all vehicles, including golf cars, categorically.

If any of the operation or safety decals on the vehicle become damaged, have been removed or cannot be easily read, they should be replaced immediately to avoid possible property damage, personal injury, or death. Contact your distributor/dealer.

### **DANGER**

- A DANGER indicates an immediate hazard that will result in severe personal injury or death.

### **WARNING**

- A WARNING indicates an immediate hazard that could result in severe personal injury or death.

### **CAUTION**

- A CAUTION with the safety alert symbol indicates a hazard or unsafe practice that could result in minor personal injury.

### **CAUTION**

- A CAUTION without the safety alert symbol indicates a potentially hazardous situation that could result in property damage.

---

## GENERAL WARNINGS

---

The following safety statements must be heeded whenever the vehicle is being operated, repaired, or serviced. **See Safety Decal and Feature Identification on page 4.** Other specific safety statements appear throughout this manual and on the vehicle.

### **DANGER**

- **Battery – Explosive gases! Do not smoke. Keep sparks and flames away from the vehicle and service area. Ventilate when charging or operating vehicle in an enclosed area. Wear a full face shield and rubber gloves when working on or near batteries.**
- **The vehicle will not provide protection from lightning, flying objects, or other storm-related hazards. If caught in a storm while driving a Club Car vehicle, exit the vehicle and seek shelter in accordance with applicable safety guidelines for your location.**

** WARNING**

- Follow the procedures exactly as stated in this manual, and heed all DANGER, WARNING, and CAUTION statements in this manual as well as those on the vehicle and battery charger.
- Do not leave children unattended on vehicle.
- Prior to leaving the vehicle unattended or servicing the vehicle, set the park brake, place the Forward/Reverse handle or switch in the NEUTRAL position, turn the key switch to the OFF position, and remove the key. Chock the wheels when servicing the vehicle.
- Improper use of the vehicle or failure to properly maintain it could result in decreased vehicle performance, severe personal injury, or death.
- Any modification or change to the vehicle that affects the stability or handling of the vehicle, or increases maximum vehicle speed beyond factory specifications, could result in severe personal injury or death.
- Check the vehicle for proper location of all vehicle safety and operation decals and make sure they are in place and are easy to read.
- Only trained technicians should service or repair the vehicle or battery charger. Anyone doing even simple repairs or service should have knowledge and experience in electrical and mechanical repair. The appropriate instructions must be used when performing maintenance, service, or accessory installation.

**PowerDrive Plus and IQ System vehicles:**

- Place Tow/Run switch in the TOW position before disconnecting or connecting the batteries. Failure to heed this warning could result in a battery explosion or severe personal injury.

**All electric vehicles:**

- To avoid unintentionally starting the vehicle, disconnect the batteries as shown (Figure 1 or Figure 2).

**IQ System vehicles:**

- After disconnecting the batteries, wait 90 seconds for the controller capacitors to discharge.

**PowerDrive System 48 and PowerDrive Plus vehicles:**

- After disconnecting the batteries, discharge the controller capacitors as follows:
  - Turn key switch to the ON position and place the Forward/Reverse handle in the REVERSE position.
  - Slowly press the accelerator pedal and keep it pressed until the reverse warning buzzer can no longer be heard. When the buzzer stops sounding, the controller capacitors are discharged.

**All electric vehicles:**

- Wear safety glasses or approved eye protection when servicing the vehicle or battery charger. Wear a full face shield and rubber gloves when working on or near batteries.
- Do not wear loose clothing or jewelry such as rings, watches, chains, etc., when servicing the vehicle or battery charger.
- Use insulated tools when working near batteries or electrical connections. Use extreme caution to avoid shorting of components or wiring.

## GENERAL INFORMATION

This manual features the following Gold Standard electric vehicles:

- Golf car
- 4-passenger vehicle
- Handyman (**see following NOTE**)
- Lynx vehicle
- Lynx 4-passenger vehicle

The electric vehicles have one of several possible powertrain configurations: PowerDrive System 48, PowerDrive Plus, and IQ System. It is important that you know which powertrain your vehicle has.

**NOTE:** Throughout this manual, the term “Handyman vehicle” is used when referring to the Golf Car vehicle equipped with a box bed. The Lynx also has a box bed, but it has larger tires, a lifted chassis, and a brush guard.

There is also a Lynx 4-passenger vehicle; unless noted otherwise, the term 4-passenger vehicle refers to both the 4-passenger Golf Car and Lynx models.

Throughout this manual, important features unique to each model are highlighted. We urge the owner/operator to read and understand this manual and to pay special attention to the features specific to his/her vehicle(s).

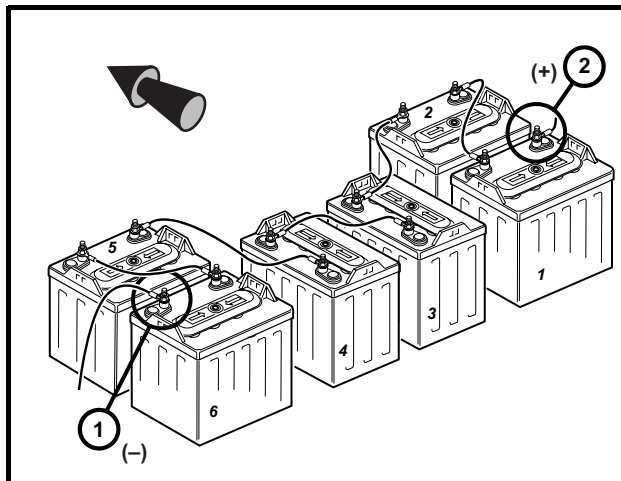

**Figure 1 PowerDrive System 48 Vehicle**

(Viewed from driver side of vehicle)

1. Remove negative battery cable.
  2. Remove positive battery cable.
- Connect battery cables in reverse order.

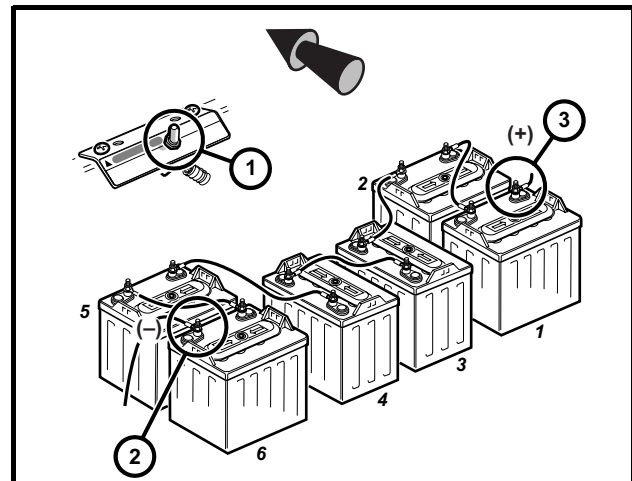

**Figure 2 PowerDrive Plus and IQ System Vehicles**

(Viewed from driver side of vehicle)

1. Place TOW/RUN Switch in TOW before disconnecting or connecting battery cables.
  2. Remove negative battery cable.
  3. Remove positive battery cable.
- Connect battery cables in reverse order.

## MODEL IDENTIFICATION

The serial number of the vehicle is printed on a bar code decal mounted on the frame directly above the accelerator pedal (Example: 2A0601-123456) (**Figure 3**). There is also a second serial number decal mounted on the front body frame behind the center dash panel. The center dash panel must be removed to view this decal. **See following NOTE.**

**NOTE:** Have the vehicle serial number available when ordering parts or making inquiries.

The model year designation of a Gold Standard vehicle is the year that the vehicle was remanufactured, rather than the year that it was originally manufactured.

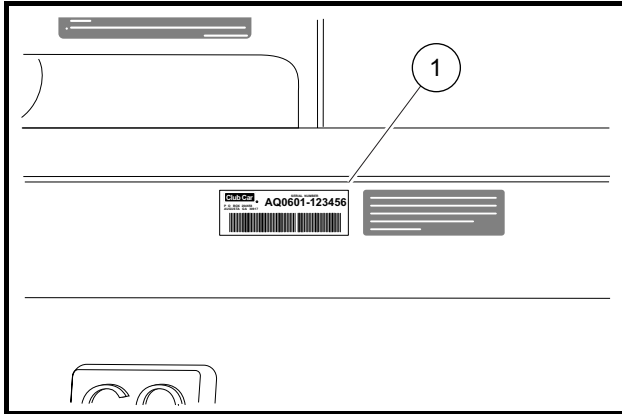

Figure 3 Serial Number Decal

## CONTROLS AND INDICATORS

See General Warnings on page 8.

### **⚠ WARNING**

- If loaning the vehicle, make sure the driver is familiar with all controls and operating procedures before allowing the vehicle to be driven.
- Any modification or change to the vehicle that affects the stability or handling of the vehicle, or increases maximum vehicle speed beyond factory specifications, could result in severe personal injury or death.
- Do not shift the Forward/Reverse handle or switch while the vehicle is moving. To avoid injury to an unsuspecting passenger or damage to the vehicle, always bring the vehicle to a full stop before shifting the Forward/Reverse handle or switch.
- Release the accelerator pedal and then press the brake pedal firmly until the vehicle stops. To avoid unintentionally starting or rolling the vehicle, set the park brake, place the Forward/Reverse handle or switch in the NEUTRAL position, turn the key switch to the OFF position, and remove the key when leaving the vehicle.

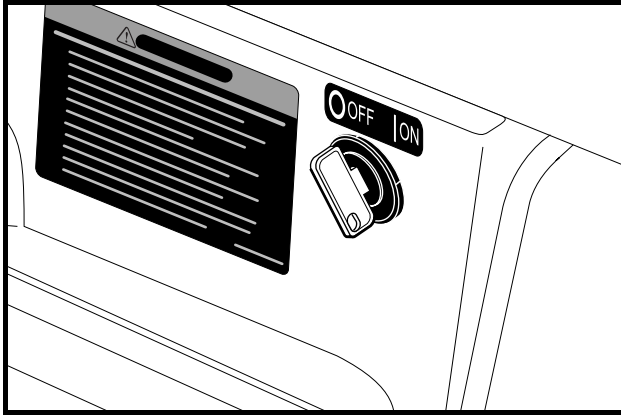

Figure 4 Key Switch

## KEY SWITCH

The key switch is mounted on the dash to the right of the steering column (**Figure 4**). It has two positions, OFF and ON, which are clearly labeled. **See following NOTE.**

**NOTE:** The key can be removed only when the key switch is in the OFF position.

## FORWARD/REVERSE CONTROL

### PowerDrive System 48 Vehicles

The Forward/Reverse handle is located on the seat support panel, below and to the right of the driver's right knee (**Figure 5**). The Forward/Reverse handle has three distinct positions: **F** (FORWARD), **R** (REVERSE), and **N** (NEUTRAL). Rotate the handle towards the driver (FORWARD) to operate the vehicle in the forward direction, or towards the passenger (REVERSE) to operate vehicle in reverse. When the handle is in the straight up position (NEUTRAL), the vehicle will not operate. Club Car vehicles operate at reduced speed in reverse. The reverse buzzer will sound as a warning when the Forward/Reverse handle is in the REVERSE position.

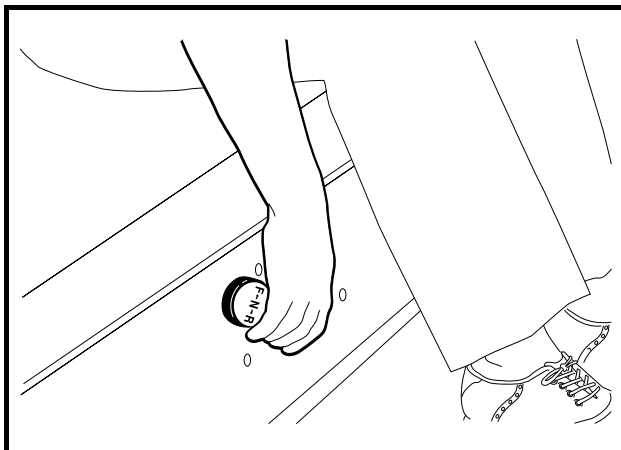

Figure 5 Forward/Reverse Handle

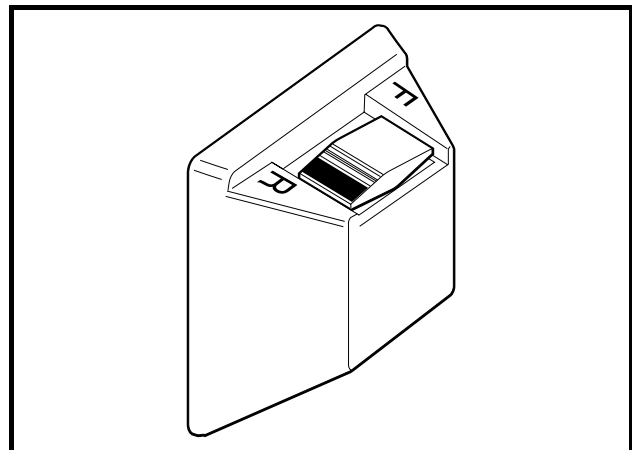

Figure 6 Forward/Reverse Rocker Switch

### PowerDrive Plus and IQ System Vehicles

The Forward/Reverse rocker switch is located in the same place as the Forward/Reverse handle on all other models: on the seat support panel below and to the right of the driver's right knee. The **F** (FORWARD) and **R**

(REVERSE) positions are clearly marked. Push down the FORWARD side of the switch to operate the vehicle in the forward direction, or push down the REVERSE side of the switch to operate the vehicle in reverse. When the rocker switch is positioned in NEUTRAL, with neither side down, the vehicle will not operate if the accelerator pedal is pressed (**Figure 6**). The reverse buzzer will sound as a warning when the Forward/Reverse switch is in the REVERSE position.

## ACCELERATOR PEDAL

The accelerator pedal is the pedal on the right, with the word GO molded into it (**Figure 7**). The operation of the accelerator pedal differs from that of an automobile. When the key switch is in the ON position, and the Forward/Reverse handle or switch is in either the FORWARD or REVERSE position, pressing the accelerator pedal will automatically release the park brake and start the vehicle moving in the direction selected (forward or reverse). As the accelerator pedal is pressed, speed will increase until full speed is reached. When the accelerator is released, power will be cut off and the motor will stop running.

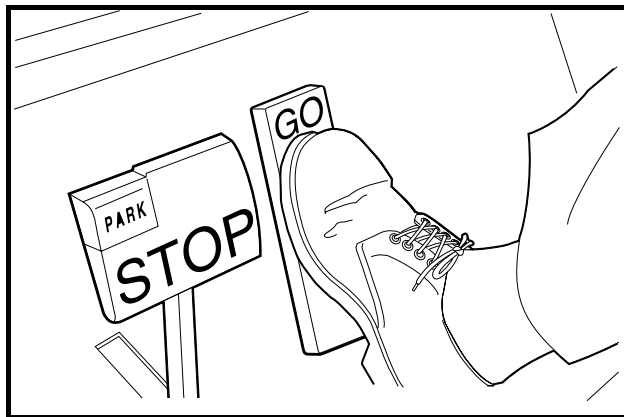

Figure 7 Accelerator and Brake Pedals

## BRAKE PEDAL

The brake pedal is the large pedal on the left with the word STOP molded into it (**Figure 7**). To slow or stop the vehicle, press the brake pedal with your foot (**Figure 8**).

## PARK BRAKE PEDAL

The park brake pedal is the small raised portion in the upper left corner of the brake pedal. It has the word PARK molded into it and the words PARK BRAKE marked on top of it (**Figure 8**). To set the park brake, press the brake pedal firmly and tilt the park brake portion of the pedal forward with your foot (**Figure 9**). **See following WARNING.**

### **⚠ WARNING**

- The park brake will release automatically when either the accelerator or brake pedal is pressed. The park brake has multiple locking positions and should be firmly pressed and locked to prevent the vehicle from rolling.

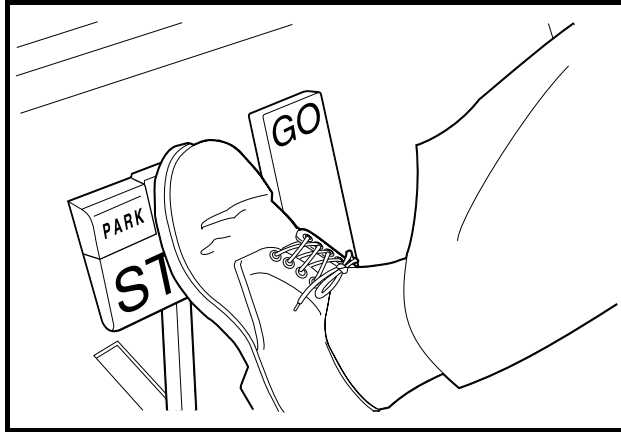

Figure 8 Brake Pedal

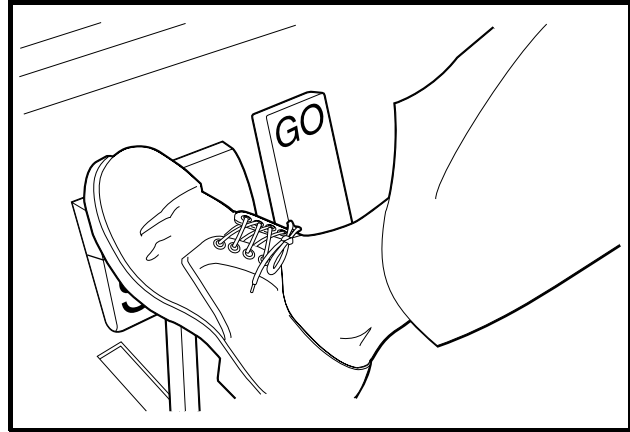

Figure 9 Park Brake Pedal

## BATTERY WARNING LIGHT

Electric vehicles feature a dash-mounted warning light (above steering column) that, when the vehicle is in operation, indicates low battery voltage or, when the vehicle is being charged, indicates a charging problem. The battery warning light is controlled by the onboard computer.

When the vehicle is in operation, the warning light will illuminate and remain illuminated if:

- Batteries' voltage drops below 48 volts when there is no load on the batteries (the vehicle is stopped and there are no accessories on).
- Batteries have discharged to less than 25% of rated capacity.

If the warning light illuminates when the vehicle is operating, there will be enough power remaining to drive the vehicle for approximately 30 minutes. However, the vehicle should be charged at the first opportunity. If the warning light illuminates and the vehicle is unable to operate for 30 minutes, have your Club Car distributor/dealer check the vehicle for a possible battery or electrical system problem.

When the batteries receive an incomplete charge because 1) the DC power cord is disconnected, 2) AC power to the charger is interrupted, 3) automatic charger shut-off occurs after 16 hours of operation, 4) the charger malfunctions, or 5) the wrong charger is used, the warning light will indicate as follows:

- The warning light will not illuminate if the charge is 90% or more complete. The onboard computer will retain in memory the amount of charge needed to fully replenish the batteries and will complete the charge during the next charge cycle.
- When the charger is unplugged, the warning light will illuminate and remain illuminated for 10 seconds if the charge is less than 90% complete but the vehicle has enough power for approximately 30 minutes of operation. This will alert the operator that the vehicle may be used, but that it must be charged to completion as soon as possible.
- The warning light will repeatedly illuminate for 10 seconds, with 4 second intervals if the charger times out at 16 hours and the batteries are not sufficiently charged. **See the battery charger owner's manual.** This indicates an abnormal charge cycle. The charger and batteries should be checked by your Club Car distributor/dealer.
- The warning light will repeatedly illuminate for 10 seconds, with 4 second intervals during a charge cycle (DC plug is still connected) if AC power to the charger is interrupted. The light will go out when AC power is restored.

**LED Light:** In addition to the warning light, there is an infrared LED in the dash light assembly, which transmits an infrared signal from the onboard computer. This signal is received by the optional Communication Display Module (CCI P/N 101831801), which provides information on the condition of the vehicle and batteries.

## TOW/RUN SWITCH

### PowerDrive Plus and IQ System Vehicles

#### **⚠ WARNING**

- Place Tow/Run switch in the TOW position before disconnecting or connecting the batteries. Failure to heed this warning could result in a battery explosion or severe personal injury.
- When the Tow/Run switch is in the TOW position, all motor braking functions, including zero speed detect, are disabled.

PowerDrive Plus and IQ System vehicles are equipped with a Tow/Run switch, located under the seat just above the Forward/Reverse switch (**Figure 10**). The switch must be in the RUN position in order to operate the vehicle. When the switch is in the TOW position, power to the vehicle electrical components is turned off and the vehicle will not operate. **See following NOTE.**

**NOTE:** After placing the Tow/Run switch in the TOW position, allow 10 seconds to elapse before switching back to the RUN position.

After placing the Tow/Run switch in the RUN position, allow 10 seconds to elapse before operating the vehicle.

The Tow/Run switch should be placed in the TOW position under the following conditions:

- **Before Towing the Vehicle:** Place the Tow/Run switch in the TOW position to disable all motor braking functions, thus preventing possible damage that could occur to the vehicle or electrical components if the vehicle is towed while the zero speed detect motor braking function is operating.
- **Before Disconnecting or Connecting Battery Cables:** Place the Tow/Run switch in the TOW position to turn off power to the vehicle electrical system, thus preventing severe arcing and possible battery explosion as the battery cables are disconnected.
- **For Long-Term Storage:** Place the Tow/Run switch in the TOW position to turn off power to the vehicle electrical system, thus preventing vehicle electrical components from discharging the batteries.

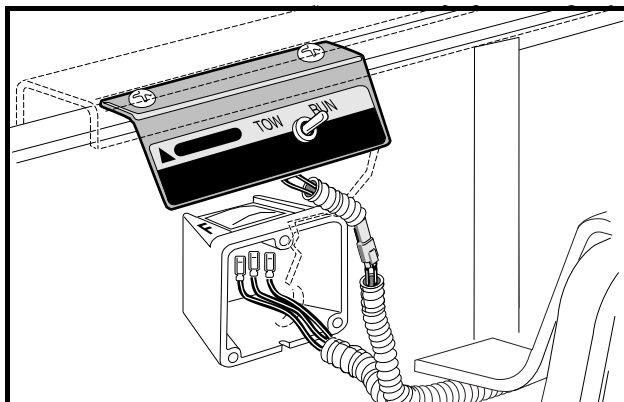

**Figure 10** Tow/Run Switch

---

## PRE-OPERATION AND DAILY SAFETY CHECKLIST

---

Each Club Car vehicle has been thoroughly inspected and adjusted at the factory; however, upon receiving your new vehicle(s), you should become familiar with its controls, indicators, and operation. Carefully inspect each vehicle to ensure that it is in proper working condition before accepting delivery.

Use the following checklist as a guide to inspect the vehicle. This checklist should be used daily to ensure that the vehicle is in proper working condition and in conjunction with the Periodic Service Schedule on page 24. Any problems should be corrected by a Club Car distributor/dealer or a trained technician.

- **General:** All the parts should be in place and properly installed. Be sure that all nuts, bolts, and screws are tight.
- **Safety and information decals:** Check to ensure that all safety and information decals are in place. **See Safety Decal and Feature Identification on page 4.**
- **Tires:** Check for proper tire pressure. Visually inspect tires for wear, damage, and proper inflation on a daily basis. **See Specifications – Golf Car, 4-Passenger, and Handyman on page 35 or Specifications – Lynx 4-passenger and Box Bed Vehicle on page 36.**
- **Batteries:** Check electrolyte to ensure that it is at the proper level (**Figure 14, Page 29**). Check battery posts. Wires should be tight and free of corrosion. On electric vehicles, charge batteries fully before first use of vehicle.
- **Charger cord, plug, and receptacle:** Visually inspect for cracks, loose connections, and frayed wiring. **See Plug and Receptacle on page 32.**
- **Wiper switch:** Be sure wiper switch cover is properly secured prior to operating the vehicle.

### **WARNING**

- **Be sure the plastic has been removed from the seat bottom before operating the vehicle. Failure to do so may result in a fire, property damage, personal injury, or death.**

---

## PERFORMANCE INSPECTION

---

After you have familiarized yourself with the vehicle controls and have read and understood the driving instructions, take the vehicle for a test drive.

Use the following checklist as a guide to inspect the vehicle and check daily for proper operation. Any problems should be corrected by a Club Car distributor/dealer or a trained technician.

### All Vehicles

- **Forward/Reverse control:** Check for proper operation. **See Controls and Indicators on page 11.**
- **Brakes:** Be sure the brakes function properly. When brake pedal is fully pressed under moderate pressure, it should not go more than halfway to the floor, and vehicle should come to a smooth, straight stop. If the pedal goes more than halfway to the floor, or if the vehicle swerves or fails to stop, have the brake system checked and adjusted as required. Brake adjustment must be maintained so that the brake pedal cannot be pressed to the floor under any circumstance.
- **Park brake:** When latched, the park brake should lock the wheels and hold the vehicle stationary (on an incline of 20% or less). It should release when either the accelerator or brake pedal is pressed.
- **Reverse buzzer:** The reverse buzzer should sound as a warning when the Forward/Reverse handle or switch is in the REVERSE position.
- **Steering:** The vehicle should be easy to steer and should not have any play in the steering wheel.

- **Accelerator:** With the key switch in the ON position and the Forward/Reverse switch in the FORWARD position, as the accelerator pedal is pressed, the motor should start and the vehicle should come up smoothly to full speed. When the pedal is released it should return to the original position and the motor should rotate freely. All Club Car vehicles operate at reduced speed in reverse.

**PowerDrive Plus and IQ System vehicles:** When the pedal is released it should return to the original position and the motor should rotate freely or go into motor braking mode. **See Pedal Up Motor Braking below.**

- **General:** Listen for any unusual noises such as squeaks or rattles. Check the vehicle's ride and performance. Have a Club Car distributor/dealer or a trained technician investigate anything unusual.

## PowerDrive Plus and IQ System Vehicles

- **Zero Speed Detect:** With the vehicle parked on level ground and the park brake disengaged, place the Tow/Run switch in the RUN position and attempt to push the vehicle. Motor braking should engage and cause resistance to rolling (moving at no more than 1 to 3 mph) (1.5 or 4.8 km/h) with the Forward/Reverse switch in any position. IQ System vehicles: When zero speed detect motor braking is engaged, the reverse buzzer should emit a distinct pattern of beeps. **See following WARNING.**

### **WARNING**

- **Zero speed detect will not limit vehicle speed to 1 mph (1.6 km/h) on very steep grades. Do not operate vehicle on slopes exceeding 20% grades.**
- **Pedal Up Motor Braking (adjustable on IQ System vehicles):** Accelerate the vehicle to full speed and then release the accelerator pedal. Motor braking should quickly and smoothly slow the vehicle to approximately 11 mph (17.7 km/h). Motor braking will disengage when vehicle slows to 11 mph (17.7 km/h). This feature is adjustable for IQ System vehicles only. Contact your local Club Car dealer/distributor to inquire about this adjustable feature.
- **Pedal Down Motor Braking:** Accelerate down an incline with the accelerator pedal pressed. When the vehicle reaches maximum designed speed, motor braking should engage and limit the vehicle to its maximum designed speed. On very steep grades, the vehicle may slightly exceed its maximum designed speed, requiring use of the brake pedal.

## DRIVING INSTRUCTIONS

### **WARNING**

- **Only licensed drivers should be allowed to drive the vehicle.**
- **If renting or loaning the vehicle, make sure the driver is familiar with all controls and operating procedures before allowing the vehicle to be driven.**
- **No more than two people should be on the vehicle at one time, except for the 4-passenger vehicle, which can carry four people.**
- **The vehicle is not specially equipped for handicapped persons:**
  - **Be sure all persons can properly operate the vehicle prior to allowing them to drive the vehicle.**
  - **Be sure all passengers are capable of securing themselves in a vehicle before allowing them to ride in one.**

WARNING CONTINUED ON NEXT PAGE...

## **WARNING**

- For night use, the vehicle must be equipped with headlights, taillights and reflectors.
- Stop the vehicle before shifting the Forward/Reverse handle. Failure to do so may result in injury to an unsuspecting passenger and (or) damage to the vehicle.
- To help avoid being struck, do not stand in front of or behind the vehicle.
- Operate the vehicle from the driver seat only.
- To help prevent falls from the vehicle, remain seated in a moving vehicle and hold on to hand holds or handrails at all times. Driver should keep both hands on the steering wheel when the vehicle is in motion.
- To help prevent the possibility of serious injury, keep your entire body inside the vehicle.
- Do not leave children unattended on vehicle.
- To help prevent overturning the vehicle, drive slowly straight up and down slopes. Avoid driving the vehicle on slopes exceeding 20% incline.
- To help avoid possible injury to an inattentive passenger and (or) damage to the vehicle, avoid sudden starts, sudden stops, and abrupt turns.
- To help avoid the possibility of losing control of or overturning the vehicle, reduce speed for adverse driving conditions such as wet grass or rough terrain.
- Do not use the vehicle on public roads. It is not designed or intended for street use and should not be licensed for use on public roads.
- Where applicable, obey all local rules concerning golf cars and off-road vehicles.
- The vehicle should be driven in only specified areas by trained drivers.
- Do not drive while under the influence of alcohol, drugs, or medications.
- To prevent overturning the vehicle, drive slowly in turns.
- Use brakes to reduce speed when coasting downhill.

No one should drive the vehicle without first being instructed in the proper operation and use of the vehicle's controls. An experienced operator should accompany each first-time driver on a test drive before allowing him/her to operate the vehicle alone.

To ensure safe operation of the vehicle, follow exactly and in order, all of the following procedures. Read and understand all instructions prior to driving the vehicle.

### **Starting the vehicle**

1. Study and understand controls.
2. Read safety warnings located on dash and above pedals.
3. For vehicles with cargo beds: Make sure load is secure.
4. Make sure everyone is seated and holding onto seat hand holds or handrails.
5. Make sure wheels are turned in desired direction and that nothing is in your path.
6. Turn key to the ON position.
7. Select direction by placing the Forward/Reverse handle or switch in desired position (F = forward or R = reverse). A buzzer will sound as a warning when the Forward/Reverse handle or switch is in the REVERSE position.
8. Place both hands on the steering wheel.
9. Slowly press accelerator pedal. The park brake will release automatically and the vehicle will start to move. As the accelerator pedal is pressed, speed will increase until full speed is reached. **See following WARNING and NOTE.**

### **WARNING**

- Operator must control vehicle speed when going downhill.
- PowerDrive Plus and IQ System vehicles only: “Pedal down” or “pedal up” motor braking may be used to help control speed when going downhill; however, steep terrain or other conditions may require that pedal braking be used in conjunction with motor braking.

## STOPPING THE VEHICLE

### **WARNING**

- Driving through water may affect the brakes. After driving through water, check effectiveness of the brakes by gently pressing the brake pedal. If the vehicle does not slow down at the normal rate, continue to press the brake pedal until the brakes dry out and normal performance returns.

### **CAUTION**

- When stopped on a hill, use the brake pedal to hold your position. Do not use the accelerator pedal to hold position.

To stop the vehicle, release the accelerator pedal and press the brake pedal with your right foot until the vehicle comes to a complete stop.

## PARKING AND LEAVING THE VEHICLE

1. After stopping the vehicle, firmly press the park brake pedal until it locks. This will prevent the vehicle from rolling.
2. Turn the key switch to the OFF position and place the Forward/Reverse handle or switch in the NEUTRAL position. Remove the key when the vehicle is not in use.
3. **PowerDrive Plus and IQ System vehicles:** When the Tow/Run switch is in the RUN position, (with the Forward/Reverse switch or key switch in any position), the zero speed detect function will prevent the vehicle from rolling at more than 1 or 3 mph (1.5 or 4.8 km/h) unless the accelerator is pressed. This prevents the possibility of a parked vehicle (with the park brake disengaged) rolling away too fast to be overtaken on foot. **See Zero Speed Detect on page 17.**

## LOADING AND UNLOADING – BOX BED VEHICLES

---

### **WARNING**

- Firmly engage the park brake before loading the vehicle.
- Do not allow riders in the cargo bed.
- Do not exceed the rated capacity of the vehicle. Rated capacity is for level surfaces only.

WARNING CONTINUED ON NEXT PAGE...

## **WARNING**

- **Overloading can affect vehicle handling or cause component failure, resulting in loss of control of vehicle and possible severe personal injury.**
- **Reduce speed and avoid sudden stops when backing up. Failure to do so may cause the vehicle to overturn or flip over backwards.**
- **Avoid stopping on a hill when loaded. If you must stop on a hill, avoid sudden starts, or rolling backwards and stopping suddenly. Failure to heed this warning may cause vehicle to overturn, possibly resulting in severe personal injury.**
- **Reduce vehicle load and speed when driving up or down slopes or on uneven terrain.**
- **Do not load the tailgate. The tailgate should be in the upright position and latched securely while the vehicle is in motion.**
- **To help avoid shifting the vehicle load and possibly overturning the vehicle, avoid sudden starts, sudden stops, and abrupt turns. make sure cargo is well-secured.**
- **The cargo's center of gravity may affect the handling, steering, and braking of the vehicle. When the vehicle is loaded, reduce speed and drive slowly in turns.**
- **Avoid top-heavy loads. the center of gravity of a load should never exceed 15 inches (38 cm) above the bottom of the cargo bed.**
- **Unload cargo bed before raising vehicle with a lift, hoist, or jack.**

When loading the vehicle, center and secure cargo as far forward as possible in the cargo bed. Do not overload the vehicle. **See the following chart for vehicle capacities.**

<b>Maximum payload capacity</b> (cargo bed load plus gross trailer weight)	150 lb. (68 kg)
<b>Maximum vehicle capacity</b> (cargo bed load, passengers, plus gross trailer weight)	550 lb. (249.5 kg)
<b>Trailer tongue weight</b>	150 lb. force (667 N)

## **TOWING WITH THE VEHICLE – GOLF CAR AND HANDYMAN VEHICLES**

---

### **WARNING**

- **Do not tow a vehicle or trailer on public streets or highways.**
- **Normal vehicle operating speed should be reduced when towing.**
- **Extreme caution should be used when towing.**
- **Total vehicle capacity, including the vehicle load rating and the gross weight of the vehicle or trailer being towed should not exceed the weight previously specified.**

**WARNING CONTINUED ON NEXT PAGE...**

---

** WARNING**

- Do not allow riders in the vehicle or trailer being towed.
- Avoid sudden starts, sudden stops, and tight turns when towing.
- Avoid stopping on a hill when towing. If you must stop on a hill, avoid sudden starts or rolling backwards and stopping suddenly. Failure to heed this warning could cause vehicle to overturn, possibly resulting in severe personal injury.

Because towing a vehicle or trailer can have adverse effects on vehicle handling, be especially cautious when towing with a Club Car vehicle. **See the preceding chart for vehicle capacities.**

Parking the vehicle with a trailer on a hill should be avoided. If you must park on a hill, apply the brakes and have someone chock the tires of the trailer. Brakes should be released to allow the chocks to absorb the load of the trailer. After the tires have been chocked, engage the park brake.

---

**TOWING THE VEHICLE**** WARNING**

- Do not tow the vehicle on public streets or highways.
- Use only approved Club Car tow bars.
- Turn the key switch to the OFF position and place the Forward/Reverse handle or switch in the NEUTRAL position before towing the vehicle.
- Extreme caution should be used when towing any vehicle.
- Do not exceed 5 mph (8 km/h) towing speed.
- Do not allow people in the vehicles being towed.
- Avoid sudden starts, sudden stops, and tight turns when towing.
- Avoid stopping on a hill when towing. If you must stop on a hill, avoid sudden starts or rolling backwards and stopping suddenly. Failure to heed this warning could cause the vehicle to overturn, possibly resulting in severe personal injury.
- Do not tow more than one Club Car vehicle with another Club Car vehicle. If more than one vehicle must be towed, an adequately powered vehicle (tractor or full sized truck) properly fitted, with a tow hitch height of 11 inches (28 cm) should be used. Only heavy-duty tow bars should be used for multi-vehicle towing. Never tow more than five vehicles at one time.
- PowerDrive Plus and IQ System vehicles only: Place the Tow/Run switch in TOW position; otherwise, the vehicle will not roll while being towed.

Golf cars and Handyman vehicles are equipped with both front and rear tow bar attaching points. A heavy duty tow bar and an onboard tow bar are available for multi-vehicle towing. The four-passenger vehicle is equipped with a front tow bar attaching point. A light duty tow bar is available for break-down towing and single vehicle towing. Observe all of the previous WARNING statements when towing.

---

## TRANSPORTING ON A TRAILER

---

### **WARNING**

- For use on public roads, the trailer must meet all federal, state, and local requirements such as taillights, brake lights, etc.
- Do not tow a Club Car vehicle behind a passenger vehicle or truck on a public road unless it is on an approved trailer.
- The vehicle to be towed should be tied securely to the trailer, with the Forward/Reverse handle or switch in the NEUTRAL position, the key switch in the OFF position, and the park brake firmly pressed and locked.
- Do not allow people in the trailer or vehicle being towed.
- Avoid sudden starts, sudden stops, and tight turns when towing.
- Avoid stopping on a hill when towing. If you must stop on a hill, avoid sudden starts or rolling backwards and stopping suddenly. Failure to heed this warning could cause the vehicle to overturn, possibly resulting in severe personal injury.
- When towing on a trailer, normal road speed of the tow vehicle should be reduced.
- Because of the added length of the trailer, use caution when making turns.
- Remove the vehicle windshield and secure the seat bottom before transporting on a trailer.

If the vehicle must be transported over long distances or on public highways, it should be transported on an approved trailer that has the approved load rating of 1200 lb. (544 kg) per vehicle being transported.

**NOTE:** A two-car trailer should be rated at  $2 \times 1200 = 2400$  lb. ( $2 \times 544 = 1088$  kg).

---

## STORAGE

---

See General Warnings on page 8.

### **WARNING**

- Turn the key switch to the OFF position, remove the key, and leave the Forward/Reverse handle or switch in the NEUTRAL position during storage. PowerDrive Plus and IQ System vehicles only: Place Tow/Run switch in the TOW position. This is to prevent unintentionally starting the vehicle or a fire hazard.
- Do not attempt to charge frozen batteries or batteries with bulged cases. Discard the battery. Frozen batteries can explode.

### **CAUTION**

- Batteries in a low state of charge will freeze at low temperatures.
- To avoid exposing electrical components to moisture and subsequent damage, do not use any type of pressure washing or steam cleaning equipment to wash the vehicle.

## PREPARING THE ELECTRIC VEHICLE FOR EXTENDED STORAGE

1. Unload the vehicle so that the tires are supporting only the weight of the vehicle.

2. Fully charge batteries. **See Charging Batteries on page 31.**
3. Batteries should be clean and free of corrosion. Wash tops and terminals of batteries with a solution of baking soda and water (1 cup (237 mL) baking soda per 1 gallon (3.8 L) of water). Rinse solution off batteries. Do not allow this solution to enter the batteries. Be sure terminals are tight. Let the terminals dry and then coat them with Battery Terminal Protector Spray (CCI P/N 1014305).
4. Store vehicle in a cool, dry place. This will minimize battery self-discharge.
5. Adjust tires to recommended tire pressure. **See Specifications – Golf Car, 4-Passenger, and Handyman on page 35 or Specifications – Lynx 4-passenger and Box Bed Vehicle on page 36.**
6. Perform semiannual periodic lubrication. **See Periodic Lubrication Schedule on page 26.**
7. Thoroughly clean front body, rear body, seats, battery compartment, and underside of vehicle.
8. Do not engage the park brake. Chock the wheels to prevent the vehicle from rolling.
9. Keep batteries fully charged during storage.
  - **PowerDrive Chargers:** Leave PowerDrive Chargers plugged in during storage. The onboard computer will automatically activate the charger when necessary. If charger cannot remain plugged in, or AC power will not be available during extended storage, disconnect the batteries for storage (**Figure 1, Page 10**).

## **CAUTION**

- **Be sure to check the batteries and charger monthly to maintain correct battery water level and to ensure the charger is operating correctly during storage.**

## **RETURNING THE STORED ELECTRIC VEHICLE TO SERVICE**

1. If necessary, connect batteries and tighten terminals to 110 in-lb (12.4 N·m).
2. Fully charge batteries.
3. Adjust tires to recommended tire pressure. **See Specifications – Golf Car, 4-Passenger, and Handyman on page 35 or Specifications – Lynx 4-passenger and Box Bed Vehicle on page 36.**
4. Perform the Pre-Operation and Daily Safety Checklist on page 16 and the Performance Inspection on page 16.

## **MAINTENANCE**

### **See General Warnings on page 8.**

To ensure trouble-free vehicle performance, it is very important to follow an established preventive maintenance program. Regular and consistent vehicle maintenance can prevent vehicle downtime and expensive repairs that can result from neglect. Use the Pre-Operation and Daily Safety Checklist on page 16, the Performance Inspection on page 16, and the following Periodic Service Schedule and Periodic Lubrication Schedule to keep the vehicle in proper working condition.

Any vehicle not functioning correctly should be removed from use until it is properly repaired. This will prevent further damage to the vehicle and avoid the possibility of injury due to unsafe conditions.

Contact your local Club Car distributor/dealer to perform all repairs and semiannual and annual periodic service.

## **WARNING**

- If any problems are found during scheduled inspection or service, do not operate the vehicle until repairs are made. Failure to make necessary repairs could result in fire, property damage, severe personal injury, or death.
- Do not wear loose clothing or jewelry, such as rings, watches, chains, etc., when servicing the vehicle.
- Turn key switch to the OFF position, remove the key, place the Forward/Reverse handle in the NEUTRAL position, and chock wheels prior to servicing.
- Hot! Do not attempt to service hot motor or resistors. Attempting to do so could cause severe burns.
- Do not work on the vehicle powertrain or under the cargo bed when it is loaded.

## **PERIODIC SERVICE SCHEDULE**

---

See General Warnings on page 8.

## **WARNING**

- Service, repairs, and adjustments must be made per instructions in the maintenance and service manual.

**NOTE:** *If the vehicle is constantly subjected to heavy use or severe operating conditions, the preventive maintenance procedure should be performed more often than recommended in the periodic service and lubrication schedules.*

*Both the Periodic Service Schedule and Periodic Lubrication Schedule must be followed to keep vehicle in optimum operating condition.*

PERIODIC SERVICE SCHEDULE		
REGULAR INTERVAL	SERVICE	
Daily service by owner	Pre-Operation and Daily Safety Checklist	See Pre-Operation and Daily Safety Checklist on page 16.
	Performance Inspection	See Performance Inspection on page 16.
	Batteries	Charge batteries (after each daily use only).
Weekly service by owner	Batteries	Check electrolyte level. Add water if necessary. See page 28.
Monthly service by owner or trained technician	Batteries	Wash battery tops and clean terminals with baking soda/water solution.
	Tires	Check air pressure and adjust if necessary.
	Wiper switch See Figure 12, Page 27 to determine applicability.	Check for cracks or other damage; make sure switch is securely fastened to frame. Check moveable contact for correct operation.
	General vehicle	Wash battery compartment and underside of vehicle.
Semiannual service by trained technician only (every 50 hours of operation or 100 rounds of golf)	Brake system	Check brake shoes; replace if necessary. See Section 6 – Wheel Brake Assemblies in the appropriate maintenance and service manual.
		Lubricate brake slides per Lubrication Schedule. See Section 6 – Wheel Brake Assemblies in the appropriate maintenance and service manual.
		Check brake cables for damage; replace if necessary.
	Electrical wiring and connections	Check for tightness and damage.
	Forward/Reverse switch	Check condition of contacts and wire connections. Make sure connections are tight.
	Front wheel alignment and camber	Check and adjust as required. See Section 7 – Steering and Front Suspension in the appropriate maintenance and service manual.
	Motor controller output regulator (MCOR) See Figure 13, Page 27 to determine applicability.	Check for loose hardware, cracks and other damage.
Annual service by trained technician only (every 100 hours of operation or 200 rounds of golf)	Batteries	If batteries are not performing as expected, see Section 13 – Batteries in the appropriate maintenance and service supplement.

**⚠ WARNING**

- If any problems are found during scheduled inspection or service, do not operate the vehicle until repairs are made. Failure to make necessary repairs could result in fire, property damage, severe personal injury, or death.

## PERIODIC LUBRICATION SCHEDULE

PERIODIC LUBRICATION SCHEDULE			
REGULAR INTERVAL	SERVICE	LUBRICATION POINTS	RECOMMENDED LUBRICANT
Semiannually by owner or trained technician (every 50 hours of operation or 100 rounds of golf)	Brake pedal shaft bearings	1	Dry Moly Lube (CCI P/N 1012151)
	Brake linkage and pivots	2	Dry Moly Lube (CCI P/N 1012151)
	Accelerator pivot rod supports	3	Dry Moly Lube (CCI P/N 1012151)
	‡ Spring-loaded ball joint (vehicles equipped with a wiper switch)	4	Dry Moly Lube (CCI P/N 1012151)
	Charger receptacle (all vehicles). Forward/Reverse switch contacts* (PowerDrive System 48 only)	5	WD-40
	Brake slides	6	Dry Moly Lube (CCI P/N 1012151)
	Front suspension (5 fittings)	7	Chassis Lube – EP NLGI Grade 2
Annually by trained technician only (every 100 hours of operation or 200 rounds of golf)	Check/fill transaxle to plug level	8	22 oz. (0.67 liters) 22 oz. (0.67 liters) SAE 30 WT. API Class SE, SF, or SG Oil (or higher)
	** Repack tapered front wheel bearings. (Sealed bearings require no lubrication.)	9	Chassis Lube – EP NLGI Grade 2

‡ Some vehicles are equipped with an MCOR throttle device (Figure 13).

\*\* Tapered front wheel bearings are provided with a chrome metal bearing cap. Sealed ball bearing front wheel bearings are provided with a black plastic bearing cap.

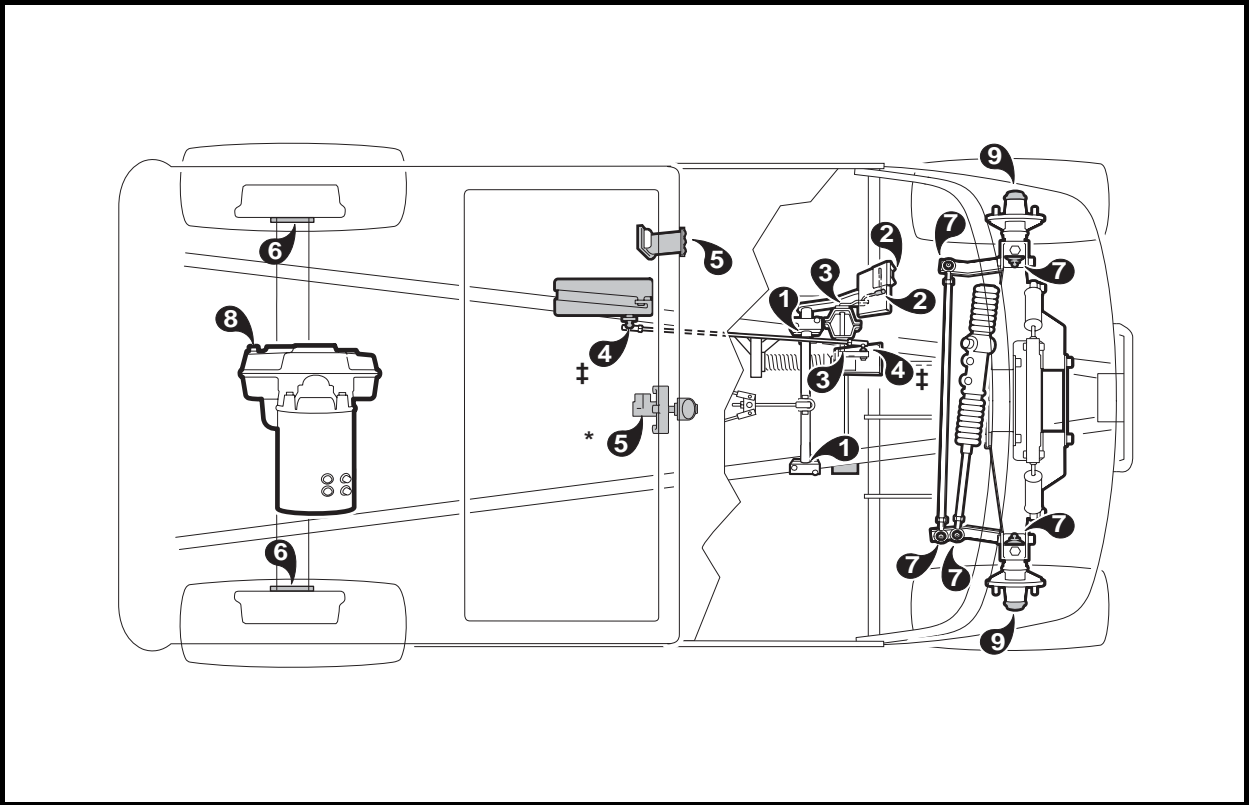

Figure 11 Lubrication Points – Electric Vehicles

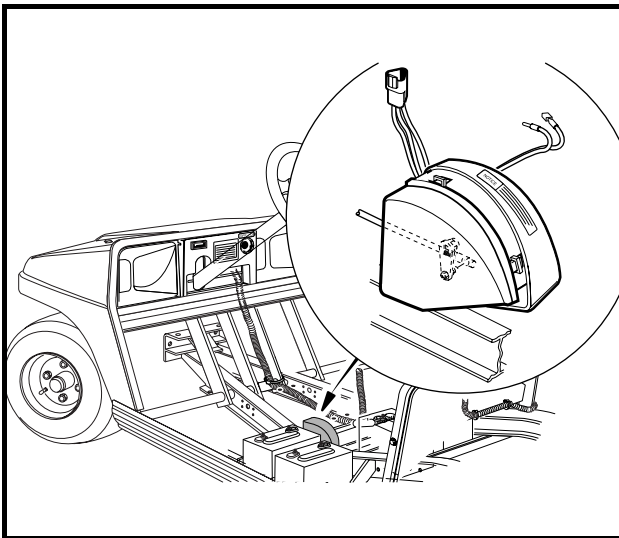

Figure 12 Vehicle Equipped with Multi-step Potentiometer (Wiper Switch)

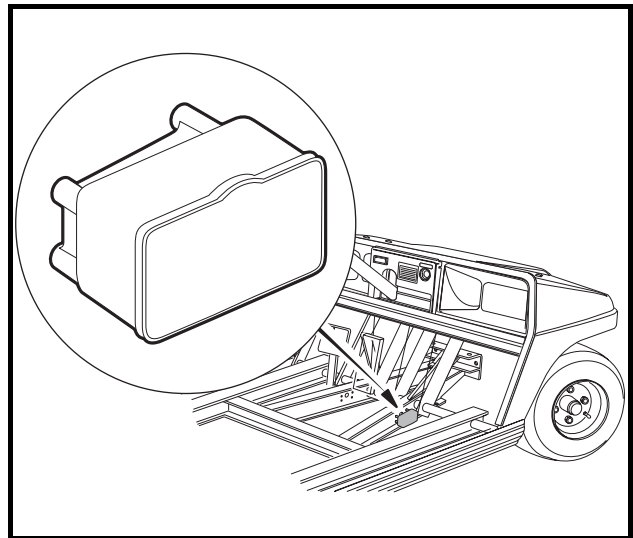

Figure 13 Vehicle Equipped with Motor Controller Output Regulator (MCOR)

---

## VEHICLE CONTROLLER

---

The electric vehicle is equipped with a solid state speed controller. In order to properly service and maintain the solid state controller vehicle, it is necessary to understand the electrical circuitry and the functions of all components in both systems. Therefore, if any repair or servicing needs to be performed, we recommend that it be performed by an authorized Club Car distributor/dealer using Club Car OEM parts.

---

## BATTERIES

---

See General Warnings on page 8.

### **DANGER**

- **Battery – Explosive gases! Do not smoke. Keep sparks and flames away from the vehicle and service area. Ventilate when charging or operating vehicle in an enclosed area. Wear a full face shield and rubber gloves when working on or near batteries.**
- **Charge batteries in a well-ventilated area only. Batteries emit hydrogen while being charged. Hydrogen is an explosive gas and must never exceed a level of 2% of the air.**
- **Battery – Poison! Contains acid! Causes severe burns. Avoid contact with skin, eyes, or clothing. Antidotes:**
  - **External: Flush with water. Call a physician immediately.**
  - **Internal: Drink large quantities of milk or water followed with milk of magnesia or vegetable oil. Call a physician immediately.**
  - **Eyes: Flush with water for 15 minutes. Call a physician immediately.**

### **WARNING**

- **Wear safety glasses or approved eye protection when servicing the vehicle or battery charger. Wear a full face shield and rubber gloves when working on or near batteries.**
- **Use insulated tools when working near batteries or electrical connections. Use extreme caution to avoid shorting of components or wiring.**

### **CAUTION**

- **On all vehicles, turn off all accessories before charging batteries.**

**NOTE:** *Recycle or dispose of discarded batteries in accordance with local, state, and federal regulations.*

Club Car electric vehicles use deep-cycle batteries. Automotive batteries should never be used.

New batteries will not deliver their full capabilities until they have been discharged and recharged 20 to 50 times. To obtain the maximum service life from new batteries, restrict vehicles with new batteries to 36 holes of use or 60 minutes of actual vehicle operation between charges in the first two months of operation. Batteries should be fully charged before first use of new vehicle, before first use of a vehicle after storage, and before releasing vehicle for use each day.

## BATTERY CARE

To keep batteries in good working condition, follow this maintenance program on a regular basis:

1. The batteries should be kept clean and free of corrosion. Wash tops and terminals of batteries with a solution of baking soda and water (1 cup (237 mL) baking soda per gallon (3.8 L) of water). Rinse solution off of the batteries. Do not allow this solution to enter the battery. Be sure terminals are tight. Let the terminals dry and then coat with Battery Terminal Protector Spray (CCI P/N 1014305). **See following NOTE.**

**NOTE:** *Dispose of waste water properly.*

2. The electrolyte level in the batteries should be checked weekly (**Figure 14**). Add water only after charging unless the electrolyte level is below the top of the plates. In this case, add just enough water to cover the plates, charge and then check the level again. Never charge batteries if plates are exposed above electrolyte level. For best battery life, add only distilled water. **See following CAUTION and NOTE.**

### **⚠ CAUTION**

- **Do not overfill the batteries.**

**NOTE:** *A battery watering gun or bottle is available at many auto parts dealers.*

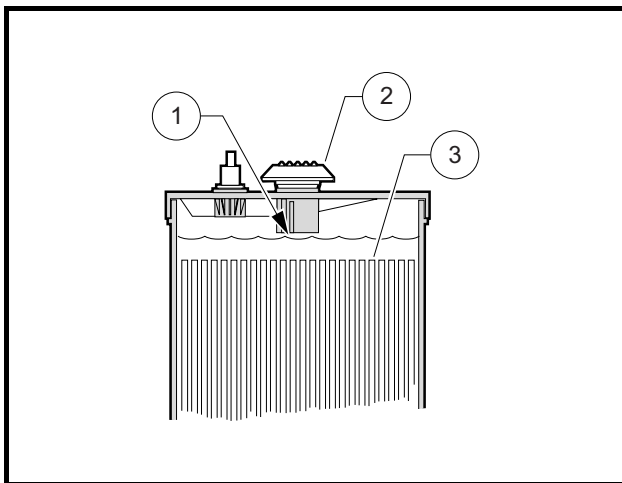

**Figure 14 Battery Electrolyte Level**

1. Level Indicator 2. Cap 3. Plates

Electrolyte level at least 1/2 inch (13 MM) above plates or to level indicator.

3. The hold-down straps should be tight enough so that the batteries do not move while the vehicle is in motion, but not so tight as to crack or buckle the battery case. Tighten hold-down retaining nuts to 40 in-lb (4.5 N·m). The terminal connections should be clean and tight, and any worn insulation or frayed wires should be replaced. Tighten battery terminals to 110 in-lb (12.4 N·m). **See following WARNING.**

### **⚠ WARNING**

- **If battery wire terminals are damaged or corroded, replace or clean them as necessary. Failure to do so may result in a fire hazard.**

4. After use, the batteries should be placed on charge. The batteries should never be left discharged any longer than absolutely necessary (do not leave discharged overnight).

---

## BATTERY CHARGER

---

### **⚠ DANGER**

- The charging area must be ventilated. Hydrogen level in the air must never exceed 2%. The total volume of air in the charging area must be changed five times per hour. Exhaust fans should be located at the highest point of the roof. Contact a local HVAC engineer.
- Do not charge the vehicle batteries with the vehicle covered or enclosed. Any enclosure or cover should be removed or unzipped and pulled back when batteries are being charged. An accumulation of hydrogen gas could result in an explosion.

### **⚠ WARNING**

- Only trained technicians should repair or service the charger. Contact your nearest Club Car distributor/dealer.
- Each charger should have its own dedicated 15 or 20 ampere separately protected (circuit breaker or fuse) single phase branch circuit, in accordance with all applicable electrical codes for the location.
- Connect the charger AC supply cord to a properly grounded, three-wire outlet of the proper voltage and frequency as shown on the charger.
- Do not use an adapter to plug the charger with a three-prong plug into a two-prong outlet. Improper connection of the equipment-grounding conductor can result in a fire or an electrical shock.
- An extension cord or electrical outlet must accept a three-prong plug. Extension cord should be a three-wire No. 12 AWG (American Wire Gauge) or No. 14 SWG (British Standard Wire Gauge), and be as short as possible. The use of improper extension cord could result in fire or an electrical shock.
- Do not operate the charger if it has received a sharp blow, was dropped, or otherwise damaged in any way.
- Have worn, cut, or damaged power cords or wires replaced immediately.
- Do not use near fuels, grain dust, solvents, thinners, or other flammables. Chargers can ignite flammable materials and vapors.
- Do not expose to rain or any liquid. Keep the charger dry.
- Never push objects of any kind into the charger through cabinet slots. They may touch dangerous voltage points or cause an electrical short circuit that could result in fire or electrical shock.
- Do not connect a stationary charger to the receptacle if the charger cord, plug, or the vehicle receptacle is broken, damaged, or does not make a good electrical connection. Fire or personal injury can result. Have a qualified technician replace the parts.
- When the charger is on, the charger DC cord may be disconnected from the vehicle receptacle slowly. Jerking or pulling the DC cord out quickly could cause arcing and burning that could damage the plug and receptacle and could cause batteries to explode.
- Do not block or cover the charger ventilation slots. The slots provide ventilation and protect the charger from overheating.
- Do not allow clothing, blankets, or other material to cover the charger.
- Do not allow the charger to operate for more than 30 minutes at 19 or more amperes.
- Install surge arrestors on incoming AC power lines. Surge arrestors will help protect electrical components in the charger and on the vehicle from all but direct or close lightning strikes.

**NOTE:** Because the vehicle onboard computer (OBC) has a storage charge feature that automatically checks and recharges the batteries as necessary every 15 days, the charger can remain plugged to the vehicle throughout the storage period.

*PowerDrive System 48 and PowerDrive Plus Vehicles:* Shortly after charging begins, the charger will shut off in order to run a self-diagnostic program (ammeter will drop to zero). Charging will resume in a few moments (ammeter returns to previous rate of charge). This will be repeated at one hour and at two hours into the charge cycle.

*IQ System Vehicles:* At one hour and two hours into the charge cycle, the charger will shut off in order to run a self-diagnostic program (ammeter will drop to zero). Charging will resume in a few moments (ammeter returns to previous rate of charge).

Each electric vehicle is supplied with a fully automatic battery charger as standard equipment. The AC cord to each charger is to be connected to a source capable of supplying 15 amperes minimum per charger.

To reduce the risk of electric shock, the battery charger must be grounded. The charger is equipped with an AC electric cord having an equipment-grounding conductor and a grounding type plug. The AC plug must be connected to an appropriate receptacle that is properly installed and grounded in accordance with the National Electrical Code and all local codes and ordinances. See the owner's manual supplied with the charger for specific operating instructions before using the charger.

The use of an extension cord with the charger should be avoided. If an extension cord must be used, use a three-conductor no. 12 AWG (American Wire Gauge) or no. 14 SWG (British Standard Wire Gauge), heavy-duty cord with ground, properly wired and in good electrical condition. Keep it as short as possible (no more than 12 feet (3.7 m)). Place all cords so they will not be stepped on, tripped over, or otherwise subject to damage or stress.

Ensure that the charger ventilation slots are unobstructed and that there is adequate ventilation.

## CHARGING BATTERIES

### **⚠ WARNING**

- Be sure all wire connections at the receptacle and the fuse link are clean and tight.
- Do not rock or bend the plug. To connect the charger plug to the vehicle receptacle, grasp the plug handle and push the plug straight into the receptacle (Figure 15, Page 32).
- Do not pull on the DC cord (Figure 16, Page 32). Do not twist, rock or bend the plug. To disconnect the charger plug from the vehicle receptacle, grasp the plug by the handle and pull the plug straight out of the receptacle.
- Do not connect a charger to the receptacle if the charger cord, plug, or the vehicle receptacle is broken, damaged in any manner, or does not make a good electrical connection. Fire or personal injury can result. Have it replaced by a qualified service person immediately.
- Failure to follow these instructions could result in damage to the charger cord, the plug, and (or) the vehicle receptacle.
- Do not use a charger if:
  - The plug is too loose or does not make a good connection.
  - The plug and receptacle feel hotter than normal during charge.
  - The plug pins or receptacle contacts are bent or corroded.
  - The plug, receptacle, or cords are cut, worn, have any exposed wires or are damaged in any way.
- Using the charger with any of the above symptoms could result in a fire, property damage, personal injury, or death.

**NOTE:** When temperatures fall below 65 °F (18.3 °C), batteries charged in unheated areas should be placed on charge as soon as possible after use. Batteries are warmest immediately after use, and cold batteries require more time to fully charge.

Insert the charger DC plug into the vehicle receptacle. The charger will turn on two to ten seconds later (**Figure 15**).

When inserting the DC plug, align the raised guide on the plug with the guide slot in the receptacle and push straight in slowly.

Club Car battery chargers interact with the vehicle's onboard computer. The computer records the amount of energy consumed during vehicle use. While the charger is plugged in, the vehicle's control circuit is locked out, preventing operation of the vehicle as well as the possibility of consequent damage to the charger and the vehicle.

Once the lockout is actuated, the charger turns on. The onboard computer then records the amount of energy being returned to the batteries. When the optimum amount of energy needed to replenish the batteries is returned, the charger will shut off. The control circuit lockout remains activated until the charger plug is disconnected from the vehicle.

Only PowerDrive System 48, PowerDrive Plus and IQ System vehicles are compatible with PowerDrive chargers. Other Club Car models or vehicles made by other manufacturers are not compatible.

As long as the charger is allowed to shut off by itself, the batteries will be fully charged. Overcharging and undercharging will normally be prevented.

Batteries should be put on charge even if they have been used for only a short period (9 holes of golf or 10 minutes). The charger is automatic and will turn off when batteries are fully charged. If the charger does not seem to be operating properly, or if the batteries seem weak, contact your local Club Car distributor/dealer.

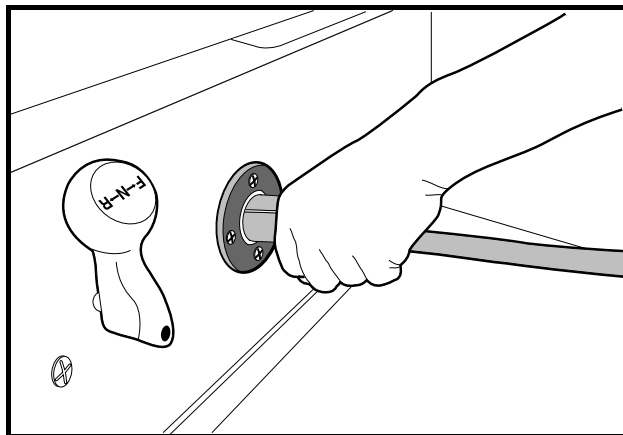

**Figure 15** Correct Insertion of Charger DC Plug

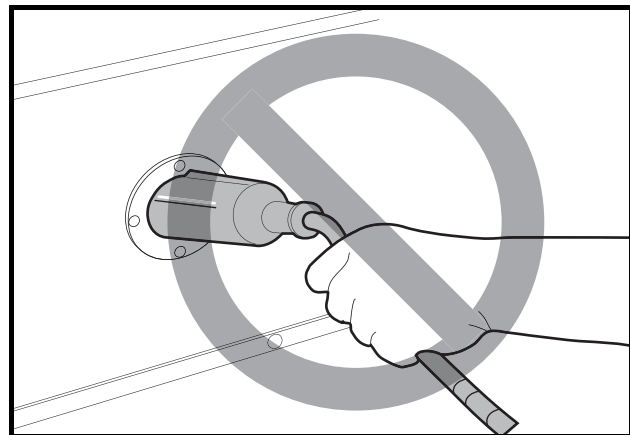
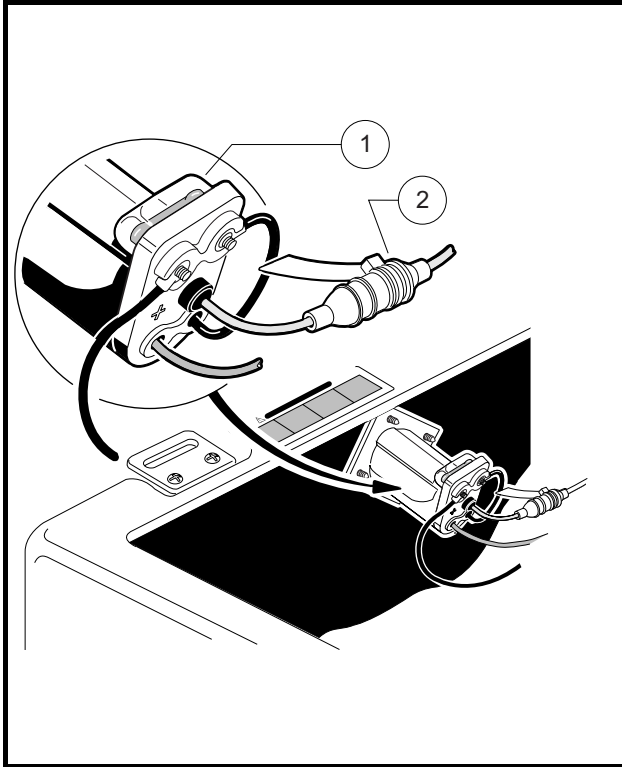

**Figure 16** Incorrect Insertion of Charger DC Plug

## PLUG AND RECEPTACLE

The charger cord, plug, and receptacle are wear items and should be inspected daily. Visually inspect them for cracks, loose connections, and frayed wiring; they must be replaced when worn or damaged. If charger plug or receptacle show signs of corrosion or the plug is difficult to insert or remove, the receptacle contacts and plug terminals should be cleaned with a good electrical contact cleaner or lightly sprayed with WD-40® brand spray lubricant. The plug should then be inserted and removed several times to ensure ease of insertion, ease of removal, and good electrical contact. **See following NOTE.**

**NOTE:** If the warning tag has been damaged or removed from the DC cord, have it replaced immediately.



**Figure 17 Sense Lead Fuse**

1. Sense Lead Fuse 2. 48-Volt Fuse Link.

## RECEPTACLE FUSE LINK

As an additional feature to protect the batteries and charging circuit from an overload, the electric vehicle is equipped with a receptacle fuse link (**Figure 17**). If the charger does not come on when the vehicle is placed on charge, visually inspect the fuse link. **See following WARNING.**

### **⚠ WARNING**

- If the receptacle fuse link is blown, determine the source of the electrical problem and correct it before replacing the fuse. Contact your nearest Club Car distributor/dealer.

## CLEANING THE VEHICLE

Club Car DS Gold Standard vehicles are equipped with ArmorFlex<sup>®</sup> front and rear bodies. Use only commercially available automotive cleaners with a sponge or soft cloth for normal cleaning. A garden hose at normal residential water pressure is adequate.

The use of any type of pressure washing or steam cleaning system is not recommended. Such a process (especially if the vehicle has an ArmorFlex rear body that is removed) will expose electrical components to moisture. Moisture entering electrical components can result in water damage and subsequent component failure.

Use non-abrasive wax products. Battery acid, fertilizers, tars, asphalt, creosote, paint, or chewing gum should be removed immediately to prevent possible stains.

The seats of the vehicle will last longer with proper cleaning. Use a solution of 10% liquid soap and warm water applied with a soft cloth. For imbedded dirt, a soft bristle brush may be used. For heavy soiling, difficult stains or scratches, blemishes, or other body damage, see Section 4 of the appropriate maintenance and service manual.

**NOTE:** *Dispose of waste water properly.*

## ACCESSORIES

---

There is a complete line of accessory equipment available from Club Car and our dealers/distributors. You can obtain the name and phone number of your closest Club Car contact by visiting our web site at [www.clubcar.com](http://www.clubcar.com) and clicking the "Dealer Locator" link.

Care should be taken that these accessories are properly installed by trained technicians, and that they are used in the manner for which they were designed. **See following WARNING.**

### **WARNING**

- **Tinted windshields and weather-proof enclosures will not protect occupants from flying objects (golf balls, etc.).**

## SUBSEQUENT OWNER REGISTRATION

---

In the event a vehicle is bought as a used vehicle, we strongly urge the new owner to register the vehicle with Club Car. This will enable us to contact you if the need arises. Please send your name, address, and serial number(s) of the vehicle(s) to Club Car, Inc., P.O. Box 204658, Augusta, Georgia 30917-4658, Attention: Vehicle Registration.

## SPECIFICATIONS – GOLF CAR, 4-PASSENGER, AND HANDYMAN

SPECIFICATIONS	POWERDRIVE SYSTEM 48 ELECTRIC	POWERDRIVE PLUS AND IQ SYSTEM ELECTRIC
<b>POWER SOURCE</b>		
<b>Drive motor:</b> Direct drive, 48 volts DC, series-wound, 3.1 hp	•	
<b>Drive motor:</b> Direct drive, 48 volts DC, shunt-wound, 3.2 hp		•
<b>Transaxle:</b> Double reduction helical gear with 12.3:1 direct drive axle	•	•
<b>Electrical system:</b> 48 volts DC, reduced speed reverse	•	•
<b>Batteries:</b> High capacity, deep cycle, Trojan PowerDrive 8-volt, 117 min. capacity	•	•
<b>Charger:</b> Automatic, 48-volt; UL and CSA listed	•	•
<b>STEERING/SUSPENSION/BRAKES</b>		
<b>Steering:</b> Self-adjusting rack and pinion	•	•
<b>Suspension:</b> Front and rear tapered mono-leaf springs with dual hydraulic shocks	•	•
<b>Brakes:</b> Dual rear wheel self-adjusting brakes with cast iron drums and single brake pedal with automatic-release park brake	•	•
<b>BODY/CHASSIS</b>		
<b>Frame/Chassis:</b> Twin I-Beam welded aluminum	•	•
<b>Front and rear body:</b> ArmorFlex®	•	•
<b>Body finish:</b> Matched paint finish over molded-in color	•	•
<b>Tires:</b> 18 x 8.50 – 8 tubeless, 4 ply rated	•	•
<b>DIMENSIONS/WEIGHT</b>		
<b>Overall length</b>	91.5 in. (232 cm)	
<b>Overall width</b>	47.25 in. (120 cm)	
<b>Overall height (with canopy)</b>	68.5 in. (174 cm)	
<b>Overall height (at steering wheel)</b>	48 in. (122 cm)	
<b>Wheelbase</b>	65.5 in. (166 cm)	
<b>Ground clearance</b>	4.5 in. (11 cm)	
<b>Front wheel tread</b>	34.5 in (88 cm)	
<b>Rear wheel tread</b>	38.5 in. (98 cm)	
<b>Weight (without batteries)</b>	476 lb. (216 kg)	494 lb. (224 kg)
<b>Forward speed</b>	12-15 mph (19-24 km/h)	
<b>Curb clearance circle (diameter)</b>	17 ft.-6 in. (533 cm)	
<b>Standard seating capacity (Golf and Handyman vehicles)</b>	2	
<b>Standard seating capacity (Four-passenger vehicle)</b>	4	
<b>LIQUID CAPACITIES</b>		
<b>Transaxle</b>	22 oz. (0.67 liters)	
<b>TIRE PRESSURE</b>		
<b>Front and rear</b>	18-20 psi (1.24-1.38 Bars)	

## SPECIFICATIONS – LYNX 4-PASSENGER AND BOX BED VEHICLE

SPECIFICATIONS	POWERDRIVE SYSTEM 48 ELECTRIC	POWERDRIVE PLUS AND IQ SYSTEM ELECTRIC
<b>POWER SOURCE</b>		
<b>Drive motor:</b> Direct drive, 48 volts DC, series-wound, 3.1 hp	•	
<b>Drive motor:</b> Direct drive, 48 volts DC, shunt-wound, 3.2 hp		•
<b>Transaxle:</b> Double reduction helical gear with 12.3:1 direct drive axle	•	•
<b>Electrical system:</b> 48 volts DC, reduced speed reverse	•	•
<b>Batteries:</b> High capacity, deep cycle, Trojan PowerDrive 8-volt, 117 min. capacity	•	•
<b>Charger:</b> Automatic, 48-volt; UL and CSA listed	•	•
<b>STEERING/SUSPENSION/BRAKES</b>		
<b>Steering:</b> Self-adjusting rack and pinion	•	•
<b>Front Suspension:</b> Tapered mono-leaf springs with dual hydraulic shocks	•	•
<b>Rear Suspension:</b> Heavy duty multi-leaf springs with dual hydraulic shocks	•	•
<b>Brakes:</b> Dual rear wheel self-adjusting brakes with cast iron drums and single brake pedal with automatic-release park brake	•	•
<b>BODY/CHASSIS</b>		
<b>Frame/Chassis:</b> Twin I-Beam welded aluminum	•	•
<b>Front and rear body:</b> ArmorFlex®	•	•
<b>Body finish:</b> Matched paint finish over molded-in color	•	•
<b>Tires:</b> 22 x 11.00– 10, 6 ply rated	•	•
<b>DIMENSIONS/WEIGHT</b>		
<b>Overall length</b>	91.5 in. (232 cm)	
<b>Overall width</b>	50.5 in. (128 cm)	
<b>Overall height (with canopy)</b>	70 in. (178 cm)	
<b>Overall height (at steering wheel)</b>	49.5 in. (126 cm)	
<b>Wheelbase</b>	66.38 in. (169 cm)	
<b>Ground clearance</b>	6.0 in. (15 cm)	
<b>Front wheel tread</b>	34.5 in. (88 cm)	
<b>Rear wheel tread</b>	38.5 in. (98 cm)	
<b>Weight (without batteries)</b>	587 lb. (266 kg)	605 lb. (275 kg)
<b>Forward speed</b>	12-15 mph (19-24 km/h)	
<b>Curb clearance circle (diameter)</b>	17 ft.-6 in. (533 cm)	
<b>Standard seating capacity (Box bed vehicles)</b>	2	
<b>Standard seating capacity (Four-passenger vehicle)</b>	4	
<b>LIQUID CAPACITIES</b>		
<b>Transaxle</b>	22 oz. (0.67 liters)	
<b>TIRE PRESSURE</b>		
<b>Front and rear: Off-road tread</b>	14-18 psi (0.96-1.24 Bars)	

# CLUB CAR<sup>®</sup> LIMITED ONE YEAR WARRANTY FOR GOLD STANDARD VEHICLE

---

## 1. WARRANTY:

CLUB CAR, INC., ("CLUB CAR") hereby warrants to the Purchaser that its Gold Standard Vehicle purchased from CLUB CAR shall be free from defects in material and workmanship under normal use and service for the periods stated below, subject to the provisions, limitations and exclusions contained in this limited warranty.

**LIMITED ONE YEAR WARRANTY:** All original equipment including battery charger and solid state speed controller, supplied by CLUB CAR are warranted with respect to parts and labor against defects in material and workmanship for a period of one year from the date of purchase.

This limited warranty covers material, workmanship and repair labor cost listed above for the period specified. Such repair labor shall be performed only by CLUB CAR, its authorized distributors or dealers, or a service agency approved by CLUB CAR.

IF THE WARRANTY REGISTRATION FORM IS NOT COMPLETED AND RETURNED TO CLUB CAR AT THE TIME OF THE ORIGINAL RETAIL SALE, PURCHASER MUST PROVIDE PROOF OF DATE OF PURCHASE WITH ANY WARRANTY CLAIM.

## 2. EXCLUSIONS:

Excluded from any CLUB CAR warranty are all fuses, filters, decals (except safety decals), spark plugs, light bulbs, lubricants, trim pieces, seats, routine wear items such as the charger plug and receptacle, brake shoes, belts, brushes, bushings, drive buttons, engine mounts, mats and pads, maintenance adjustments, cosmetic deterioration, and items which deteriorate or fail due to exposure or ordinary wear and tear. Batteries and onboard computer are covered under a separate CLUB CAR Limited REserve warranty. Also excluded from any CLUB CAR warranty is damage to a golf car or component resulting from a cause other than a defect including unreasonable or unintended strain or use, improper installation of accessories, installation of parts or accessories that are not original equipment, overloading, accident, alteration, abuse or neglect.

Transportation expenses for warranty services are also excluded from this warranty.

## 3. VOIDING OF WARRANTY:

THIS AND ANY OTHER WARRANTY SHALL BE VOID IF THE VEHICLE IS ABUSED OR USED IN AN UNINTENDED MANNER OR SHOWS INDICATIONS THAT IT HAS BEEN ALTERED IN ANY WAY, INCLUDING, BUT NOT LIMITED TO, MODIFICATION OF THE SPEED GOVERNOR, BRAKING SYSTEM, STEERING, TRANSAXLE, OR OTHER OPERATING SYSTEMS OF THE VEHICLE TO CAUSE IT TO PERFORM OUTSIDE CLUB CAR SPECIFICATIONS. THE WARRANTY IS LIKEWISE VOID IF THE VEHICLE INVOLVED SHOWS INDICATIONS THAT REASONABLE OR NECESSARY MAINTENANCE AS OUTLINED IN THE OWNER'S MANUAL AND MAINTENANCE AND SERVICE MANUAL WAS NOT PERFORMED AT THE TIME AND IN THE MANNER SPECIFIED IN SUCH MANUALS.

## 4. SOLE REMEDY:

CLUB CAR's liability under this limited warranty, or in any action whether based upon warranty, contract, negligence, strict product liability, or otherwise, shall be the repair or replacement, at CLUB CAR's option, of the vehicle or component thereof that CLUB CAR deems to be defective. Replacement shall mean furnishing, during the applicable limited warranty period, a factory-reconditioned vehicle or component thereof that is identical or reasonably equivalent to the warranted product or component at no cost to the purchaser. Repair shall mean remedying a defect in the vehicle or component thereof at no cost to the purchaser during the applicable limited warranty period. If CLUB CAR elects to repair the vehicle, it may provide factory-reconditioned parts or components. All parts and components replaced under warranty shall become the property of CLUB CAR.

## 5. HOW TO MAKE A WARRANTY CLAIM:

To make a warranty claim under this limited warranty, you must present the vehicle or defective component to an authorized CLUB CAR distributor or dealer or send the defective component, freight prepaid, to WARRANTY SERVICES, CLUB CAR, INC., 4125 Washington Road, Evans, Georgia 30809, U.S.A., 706-863-3000.

## 6. DISCLAIMER:

THIS LIMITED WARRANTY IS EXCLUSIVE. CLUB CAR MAKES NO OTHER WARRANTY OF ANY KIND, EXPRESSED OR IMPLIED. ANY IMPLIED WARRANTIES OF MERCHANTABILITY OR FITNESS FOR A PARTICULAR PURPOSE WHICH EXCEED THE OBLIGATIONS OR TIME LIMITS STATED IN THIS WARRANTY ARE HEREBY DISCLAIMED BY CLUB CAR AND EXCLUDED FROM THIS WARRANTY. THE PURCHASER AND CLUB CAR EXPRESSLY AGREE THAT THE REMEDY OF THE REPLACEMENT OR REPAIR OF THE DEFECTIVE VEHICLE OR COMPONENT THEREOF IS THE SOLE REMEDY OF THE PURCHASER. CLUB CAR MAKES NO OTHER REPRESENTATION OR WARRANTY OF ANY KIND, AND NO REPRESENTATIVE, EMPLOYEE, DISTRIBUTOR OR DEALER OF CLUB CAR HAS THE AUTHORITY TO MAKE OR IMPLY ANY REPRESENTATION, PROMISE OR AGREEMENT, WHICH IN ANY WAY VARIES THE TERMS OF THIS WARRANTY.

## 7. NO CONSEQUENTIAL DAMAGES:

IN NO EVENT SHALL CLUB CAR BE LIABLE FOR ANY INCIDENTAL OR CONSEQUENTIAL DAMAGES INCLUDING, BUT NOT LIMITED TO, LOSS RELATED TO PROPERTY OTHER THAN THE VEHICLE, LOSS OF USE, LOSS OF TIME, INCONVENIENCE, OR ANY OTHER ECONOMIC LOSS.

Some states allow neither limitation on the duration of an implied warranty nor exclusions or limitation of incidental or consequential damages. Therefore, the above limitations or exclusions may not apply to you.

This warranty gives you specific legal rights, and you may also have other rights, which vary from state to state.

## 8. INFORMATION:

For further information contact WARRANTY SERVICES, CLUB CAR, INC., P.O. Box 204658, Augusta, Georgia 30917-4658, U.S.A., 706-863-3000.

## 9. WARNING:

Any modification or alteration of any vehicle beyond factory specifications, including those that affect the weight distribution, stability, or speed of the vehicle, can cause serious personal injury or death.

# CLUB CAR® LIMITED THREE YEAR WARRANTY FOR GOLD STANDARD VEHICLE POWERDRIVE® T-875 8-VOLT BATTERIES & ONBOARD COMPUTER

---

CLUB CAR, INC., ("CLUB CAR") hereby warrants to the original purchaser that the new PowerDrive T-875 8-volt Battery and the new Onboard Computer installed in the electric vehicle equipped with the PowerDrive System 48, PowerDrive Plus or IQ System™ purchased from CLUB CAR will be free from defects in material and workmanship and will provide 60 minute discharge capacity for a period of three years or 18,000 energy units, whichever first occurs, from the date of purchase subject to the terms and conditions contained herein.

This limited warranty only covers defects in material and workmanship for a period of three years or 18,000 energy units as recorded by the Onboard Computer, whichever first occurs, from the date of purchase.

The battery or computer should be returned to an authorized CLUB CAR distributor or dealer with evidence of proof of purchase date and number of rounds, freight prepaid. CLUB CAR reserves the right to test any computer and test or recharge any battery returned for warranty, and to verify number of rounds played by accessing information contained in the PowerDrive System 48, PowerDrive Plus or IQ System Onboard Computer.

## LIMITED WARRANTY EXCLUSIONS

THE PROVISIONS OF THIS LIMITED WARRANTY SHALL NOT APPLY TO FAILURE DUE TO:

- 1) Abuse such as overcharging, undercharging, improper fluid levels, loose wiring, or rusted or corroded hardware;
- 2) Lack of proper maintenance as outlined in the electric vehicle owner's manual;
- 3) Damages caused by improper installation of the battery or computer;
- 4) Neglect, breakage, freezing, fire, explosion, wreckage, the addition of any chemical, or the operation of the battery in an uncharged condition (below half charge - 1,200 specific gravity);
- 5) Vehicles charged by systems other than the CLUB CAR PowerDrive Charger;
- 6) A battery damaged by a defective charger.

---

Without limiting the generality of the foregoing in any way, and as part of its limited warranty exclusion, CLUB CAR does not warrant that its PowerDrive battery or Computer is suitable for use in any application other than in its products. As in the use of any battery, a prudent owner will read and study the charger owner's manual, the electric vehicle owner's manual, the operator instructions, and the battery warning labels; and will exercise due care in working on or around batteries.

Transportation expenses for warranty services are also excluded from this warranty.

#### **WARRANTY LIMITATIONS**

CLUB CAR's liability under this limited warranty shall be to replace a defective battery or computer. Replacement shall be furnishing a new or used battery or computer with sufficient life to complete the remainder of the warranty term, which is identical or reasonably equivalent to the warranted product at no cost to the purchaser during the three-year or 18,000 Energy Unit limited warranty period, whichever first occurs. All parts and components, which are replaced under this limited warranty, become the property of CLUB CAR.

**THIS LIMITED WARRANTY IS EXCLUSIVE. CLUB CAR MAKES NO OTHER WARRANTY OF ANY KIND, EXPRESSED OR IMPLIED. ANY IMPLIED WARRANTIES OF MERCHANTABILITY OR FITNESS FOR A PARTICULAR PURPOSE WHICH EXCEED THE OBLIGATIONS OR TIME LIMITS STATED IN THIS WARRANTY ARE HEREBY DISCLAIMED BY CLUB CAR AND EXCLUDED FROM THIS WARRANTY. THE PURCHASER AND CLUB CAR EXPRESSLY AGREE THAT THE REPLACEMENT OR REPAIR OF THE DEFECTIVE VEHICLE OR COMPONENT THEREOF IS THE SOLE REMEDY OF THE PURCHASER. CLUB CAR MAKES NO OTHER REPRESENTATION OR WARRANTY OF ANY KIND AND NO REPRESENTATIVE, EMPLOYEE, DISTRIBUTOR OR DEALER OF CLUB CAR HAS THE AUTHORITY TO MAKE OR IMPLY ANY REPRESENTATION, PROMISE OR AGREEMENT, WHICH IN ANY WAY VARIES THE TERMS OF THIS WARRANTY.**

This battery or computer is intended to be serviced by persons with training and experience with CLUB CAR PowerDrive System 48, PowerDrive Plus and IQ System electric vehicles. Any other use renders the Limited Warranties expressed herein and all implied warranties null and void and same are hereby excluded.

**ALSO EXCLUDED FROM THIS LIMITED WARRANTY ARE ANY AND ALL INCIDENTAL OR CONSEQUENTIAL DAMAGES INCLUDING, BUT NOT LIMITED TO, LOSS OF USE OR REVENUE, LOSS OF TIME, INCONVENIENCE OR ANY OTHER ECONOMIC LOSS.**

Damage not resulting from a defect in material or workmanship or that occurs due to abuse or neglect (including failure to provide reasonable and necessary maintenance), accident or alteration is excluded from this limited warranty.

Some states allow neither limitation on the duration of an implied warranty nor exclusions or limitations of incidental or consequential damages. Therefore, the above limitations or exclusions may not apply to you.

This warranty gives you specific legal rights, and you may also have other rights, which vary from state to state.

For further information contact WARRANTY SERVICES, CLUB CAR, INC., P.O. Box 204658, Augusta, Georgia, 30917-4658, U.S.A., 706-863-3000.





Publication Part Number 103372924  
Edition Code 0607B0907A

Manual No. 103372924



**Club Car, Inc.**  
P.O. Box 204658  
Augusta, GA 30917-4658  
USA

<b>Web</b>	www.clubcar.com
<b>Phone</b>	1.706.863.3000 1.800.ClubCar
<b>Int'l</b>	+1 706.863.3000
<b>Fax</b>	1.706.863-5808