

GATSBY USER'S MANUAL



WARNING

- Read the User Manual carefully before operating the **GATSBY**
- If you do not fully understand any part of this manual, please contact your dealer or any of our Service Centres
- Read this manual step by step, as injury or damage may occur from misuse!

WARNING

- Electromagnetic Interference ("EMI") can cause powered vehicles to behave erratically which could be dangerous to the user
- For your safety and protection, it is **IMPERATIVE** that you take time to read in Section 5 the "EMI WARNINGS" before operating the **GATSBY**

CONTENTS

1.	INTENDED USE	3
2.	SHORT PRODUCT INTRODUCTION	3
3.	WARNING AND SAFETY SYMBOLS	4
4.	SAFETY INSTRUCTIONS	8
5.	EMI / RFI WARNINGS	20
6.	CHARGING THE BATTERIES	22
7.	ADJUSTMENTS INSTRUCTIONS	24
8.	OPERATION	29
9.	CARE AND MAINTENANCE	34
10.	TROUBLESHOOTING AND REPAIR	37
11.	WARRANTY	40
A1.	SPECIFICATIONS	41
A2.	DISASSEMBLY + ASSEMBLY	43
A3.	STORAGE INSTRUCTIONS	45
A4.	MARKING PLATE	46

1. INTENDED USE

The intended use of the Rehasys Mobility Scooter, **GATSBY** model, is to provide mobility to normal and disabled adults with limited walking that have the capability of operating a scooter.

2. SHORT PRODUCT INTRODUCTION

Congratulations for choosing **GATSBY** as your electrically powered scooter.

- **GATSBY** is designed for a maximum occupant mass of 150 kg (332 lbs).
- **GATSBY**'s maximum forward speed is 15 km/h. Maximum reverse speed is 6 km/h.
- **GATSBY** is an indoor /outdoor scooter designed to work in environmental conditions ranging between -8°C /18°F and 45°C /113°F
- **GATSBY** will operate in light rain showers, but extended use in *heavy rain or snow* is not recommended.
- **GATSBY** is easy to operate. The relatively large wheels let the user drive on unpaved roads, over moderately rough terrain and over obstacles as high as 50 mm (2"). Refer to specifications sheet in Appendix A1 for the required tyre pressure.
- **GATSBY** can climb slopes with angles and loads as detailed in Figure 1 (page 10).
- **GATSBY**'s maximum **safe** slope is: 8° (14 %).
- The braking system stops the **GATSBY** smoothly and within a short distance after the throttle control lever is released. A handbrake is also available for additional security.
- **GATSBY** is equipped with both front and rear shock absorbers to give the user a comfortable and smooth drive, even when using the vehicle on moderately rough roads. The seat is spacious and comfortable, and can be rotated for easy access (standard seats). It can be adjusted forward and backward, and up and down by a technician.
- All controls are conveniently mounted on the tiller and are simple to operate. Under normal conditions, the **GATSBY** can travel up to 40 km before the batteries require recharging.
- After reading through this entire manual and before using the **GATSBY**, do a visual check of all the parts of the vehicle, to make sure that there is no visible damage. If you have any questions or concerns, contact your dealer.
- **GATSBY** was designed to use only maintenance-free sealed batteries.
- The unoccupied **GATSBY** is suitable for land, sea and /or air transport.
- Information regarding **GATSBY** scooter will be available as long as reasonable necessary. Contact the manufacturer or nearest importer for support.
- Any changes to information provided for existing users shall be clearly communicated in the website of Rehabilitations-Systeme AG – www.rehasys.ch - if they are important for patient safety.

3. WARNING AND SAFETY SYMBOLS



WARNING! An authorized supplier or qualified technician must perform the initial setup of this scooter, and must perform all of the procedures in this manual.

The symbols below are used throughout this user's manual and on the scooter to identify warnings and important information. It is very important for you to read them and understand them completely.



WARNING! Indicates a potentially hazardous condition / situation. Failure to follow designated procedures can cause either personal injury, component damage, or malfunction. On the scooter, this is a triangular black symbol.



MANDATORY! These actions must be performed as specified. Failure to perform mandatory actions can cause personal injury and/or equipment damage. On the scooter, this is a white symbol on a dark background.



PROHIBITED! These actions are prohibited. These actions must not be performed at any time or under any circumstances. Performing a prohibited action can cause personal injury and/or equipment damage. On the scooter, this is a black symbol with a circle and slash.



Please note and strictly adhere to the following Safety Instructions. Additional Warnings and Notices are printed in this user manual; it is imperative that you read carefully all chapters of this manual before operating the GATSBY. It is also advisable to refresh your memory by re-reading this manual periodically.



Get acquainted with the GATSBY and its operational features before driving it. Drive slowly (speed limit dial set to MIN) until you get used to the GATSBY, to its various functions, safety features, and to its braking capabilities and limitations.



Watch carefully for pedestrians and drive your GATSBY accordingly. In crowded areas, always drive with the speed limit dial set to MIN. Drive only where permitted according to all applicable local laws and ordinances. GATSBY is 66 cm (26") wide. Take great care not to hit persons or any objects around the vehicle.



Never remove any of the GATSBY safety parts such as fenders, plastic covers or emergency brake lever. Never remove any of the Warning labels.



Never put your hands, fingers, or legs into any moving parts or under any protective cover, since moving parts and hot surfaces are under those covers.



When making adjustments (folding the seat back, adjusting the armrest, moving the seat forward or backward, adjusting the tiller distance), as well as when squeezing the throttle control lever, always take care that your hands and fingers are not trapped between any of the moving parts. When moving the tiller forward or backward, be careful not to trap your fingers in the mechanism.



The load in the front basket must not exceed 5 kg (11 lbs). The **GATSBY** is designed to carry ONE person only on the Single Seat model. Never operate it with an additional person on board, including a child.



Never inflate the **GATSBY** tyres more than the manufacturer's recommended pressure shown on the tires.



Never use the **GATSBY** on stairs. Never try to go over an obstacle that is more than the maximum recommended slope angle and obstacle height given in the specification sheet. When driving over an obstacle, always drive so that the front of the **GATSBY** is facing the obstacle.



If for any reason the **GATSBY** does not stop when you release the throttle control lever, or takes longer to stop than it should (3 meters on a level surface), turn the main key switch to OFF, and contact your dealer.



Do not use the **GATSBY** in heavy rain or extreme humidity, or at temperatures below -8°C (-18°F) or above $+45^{\circ}\text{C}$ ($+113^{\circ}\text{F}$).



The seat weighs 21 kg (46 lbs). Each battery weighs a minimum of 22.5 kg (49.6 lbs). Be careful when lifting the seat and the batteries. See instruction for lifting the seat and the batteries in Chapter 7: Adjustments Instructions and Chapter 10: Troubleshooting and Repair. Always lift using your knees and legs, not your back.



Use lead acid maintenance-free sealed batteries only.



If the **GATSBY** is involved in any kind of an accident in which parts are damaged, you must get a qualified technician to examine it before continuing to use it.



WARNING! Special care must be taken to prevent children from operating the **GATSBY**.

Do not allow unsupervised children to play near the **GATSBY** scooter while the batteries are charging.



Always drive carefully. Adjust your speed according to road conditions. When turning at high speed, the **GATSBY** can become unstable. Before making sharp turns, reduce speed to minimum to prevent roll-over.



The **GATSBY** is able to go up slopes higher than the recommended safe slope. However, do not drive on slopes whose incline you do not know. Always drive very slowly and do not drive on the side of such slopes.

Before starting to drive, make sure your emergency brake operates properly.



Do not release either the manual or the manual release lever of the electromagnetic brake (EMB) when the **GATSBY** is on a slope.

When on any sort of an incline, never place the **GATSBY** in freewheel mode while seated on it or standing next to it.



The lights of the **GATSBY** should be on when visibility is reduced, day or night.



Since your seat upholstery is fire resistant, do not cover it or replace with any upholstery other than upholstery of the same kind. When removing the battery cover, watch out for hot parts. The motor, axle, EMB, electronic cards and electronic controller might be hot, Do not touch them until you have checked their temperature.



Make sure your fingers are not squeezed between the levers and the rubber grip.



Do not use a cell phone, walkie-talkie, laptop, or other radio transmitter while operating the **GATSBY**.



Removal of the grounding prong can create electrical hazard. If it is necessary to use a 2-pronged electrical outlet, properly install an approved 3-pronged adapter.



Do not connect an extension cord to the AC/DC converter or to the battery charger.



Keep tools and other metal objects away from the battery terminals. Contact with tools can cause electrical shock. Do not sit on the **GATSBY** when it is on any type of lift / elevation product.



Explosive conditions exist



Disposal and recycling: Contact your authorized dealer for information on proper disposal of your **GATSBY** and its packaging.



Wear safety glasses.



Contains lead



The battery charger is for indoor use only.



Flammable material. Do not expose to open flame.



At the rear of the **GATSBY** is the manual release lever of the Electromagnetic Brake EMB. When using this lever, be careful not to touch the internal surface of the motor, as it could be very hot and cause injury. See the warning label at the rear of the scooter near the lever.

4. SAFETY INSTRUCTIONS

GENERAL



MANDATORY Do not operate your new **GATSBY** scooter for the first time without reading and understanding this User Manual completely.

The contents of this manual are based on the expectation that a mobility device expert has properly fitted the **GATSBY** scooter to the user and has assisted the prescribing healthcare professional and/or the authorized dealer to give instructions for the use of the product.

There are certain situations, including some medical conditions, where the user will need to practice operating the **GATSBY** scooter in the presence of a trained attendant. A trained attendant can be defined as a family member or care professional specially trained in assisting a user in various daily living activities.

Visually impaired people should get consultancy by healthcare professional before attempting to drive the **GATSBY** scooter.

As you begin using your **GATSBY** scooter during daily activities, you will probably encounter situations in which you will need some practice. Simply take your time and you will soon be in full and confident using control.

Below are some precautions, tips, and other safety considerations that will help you operate the **GATSBY** scooter safely.

MODIFICATIONS



We have designed and engineered your **GATSBY** to provide maximum mobility and utility. Under no circumstances should you modify, add, remove, or disable any feature, part, or function of your **GATSBY**.

WARNING! Do not modify your GATSBY in any way not authorized by the manufacturer. Do not use accessories if they have not been tested or approved by the manufacturer.

REMOVABLE PARTS



WARNING! Do not attempt to lift or move your GATSBY by any of its removable parts, including the armrests, seat, or shroud.

PRE-RIDE SAFETY CHECK



Get to know the feel of your **GATSBY** and its capabilities. We recommend that you perform a safety check before using the scooter to make sure your **GATSBY** operates smoothly and safely.

Perform the following inspections prior to using your scooter:

- ✓ Check for proper tire inflation. Maintain but do not exceed the psi/bar/kPa air pressure rating indicated on each tire (refer to Specification sheet for details).
- ✓ Check all electrical connections. Make sure they are secure and not corroded.
- ✓ Check all harness connections. Make sure they are secured properly.
- ✓ Check the brakes – electromagnetic and handbrake.
- ✓ Check the battery charge level.
- ✓ If you discover a problem, contact your authorized **GATSBY** dealer for assistance.

TIRE INFLATION



Your **GATSBY** is equipped with pneumatic tires. Check the tire pressure at least once a week. Proper inflation pressures will prolong the life of your tires and help ensure the smooth operation of your **GATSBY**.

WARNING! It is critically important that the psi/bar/kPa air pressure indicated on each tire is maintained at all times. Do not under-inflate or over-inflate the tires. Under-inflation may result in loss of control, and over-inflation may burst the tire. Failure to maintain the indicated pressure rating at all times may result in tire and/or wheel failure.

WARNING! Inflate your scooter tires from a regulated air source with an attached pressure gauge. Inflating your tires from an unregulated air source could over-inflate them, resulting in a burst tire.

WEIGHT LIMITATIONS



Your scooter is rated for a maximum weight capacity. Refer to Specification sheet for details.

MANDATORY! Stay within the specified weight capacity for your GATSBY. Exceeding the weight capacity voids your warranty. We will not be held responsible for injuries and/or property damage resulting from failure to observe weight limitations.

WARNING! Do not carry passengers on your scooter. Carrying passengers on your GATSBY may result in instability.

INCLINE INFORMATION



More and more buildings have ramps with specified degrees of inclination, designed for easy and safe access. Some ramps may have turning switchbacks (180-degree turns) that require you to have good cornering skills on your **GATSBY** scooter.

WARNING! Move the seat forward when driving up on a large incline. Danger of tilting over backwards (refer also to Figures 1 and 3).

- ✓ Proceed with extreme caution as you approach the downgrade of a ramp or incline.
- ✓ Take wide turns with your **GATSBY** scooter around any tight corners. If you do that, the scooter's rear wheels will follow a wide arc. Do not cut the corner short, and do not bump into or get hung up on any railing corners.
- ✓ When driving down a ramp, keep the **GATSBY** scooter's speed adjustment set to the slowest speed setting to ensure a safely controlled descent.
- ✓ Avoid sudden stops and starts.
- ✓ Refer to Figure 1 to determine the maximum slope.

Figure 1: Maximum Recommended Incline Angles

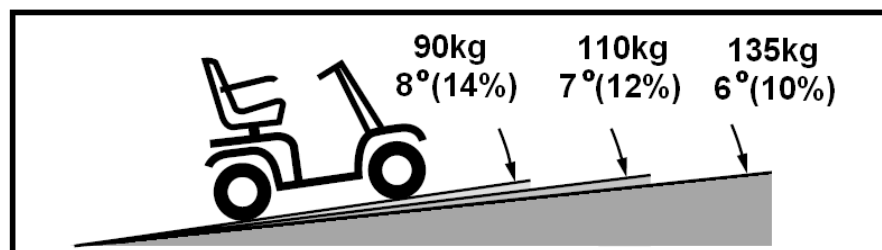

When driving up an incline, try to keep your **GATSBY** moving. If you must stop, start up again slowly, and then accelerate cautiously. When driving down an incline, set the speed switch to MIN and drive forward only. If **GATSBY** starts to move down the incline faster than you want, allow it to come to a complete stop by releasing the throttle control lever, then push the throttle control lever forward slightly to ensure a safely controlled descent. When necessary, you can also make use of the handbrake.

WARNING! When on any incline, never place the GATSBY in freewheel mode while seated on it or standing next to it.

WARNING! When climbing an incline, do not zigzag or drive up at an angle. Always drive your GATSBY scooter straight up the incline. This greatly reduces the possibility of tipping over or a fall. Always exercise extreme caution when driving on an incline.

WARNING! Do not drive your GATSBY scooter across an incline or diagonally up or down an incline; if possible, do not stop while driving up or down an incline.

WARNING! Do not drive up or down a potentially hazardous incline (e.g., areas covered with snow, ice, cut grass, or wet leaves).

WARNING!

Even though your GATSBY is capable of climbing slopes greater than those illustrated in Figure 1, do not, under any circumstances, exceed the incline guidelines or any other specifications presented in this manual. Doing so could cause your GATSBY to become unstable. Note that public accesses ramps are not subject to government regulation in all countries, and therefore do not necessarily have the same standard degree of slope.

Other inclines may be natural or not be designed specifically for scooters. Figure 1 illustrates your GATSBY's stability and its ability to climb includes under various weight loads and under controlled testing conditions.

These tests were conducted with the GATSBY seat in the highest position and in its farthest rearward position. Use this information as a guideline. Your GATSBY ability to travel up inclines is affected by your weight, scooter speed, your angle of approach to the incline, and your GATSBY setup.

WARNING! Any attempt to go up or down a slope steeper than shown in Figure 1 may bring your GATSBY in unstable position and cause it to tip.

WARNING! Never carry an oxygen tank weighing more than 6.8 kg (15 lbs). Never put more than 5 Kg (11 lbs) in the front basket.

When you approach an incline, it is best to lean forward (Figures 2 and 3). This shifts the centre of gravity of you and your GATSBY toward the front of the GATSBY for improved stability.

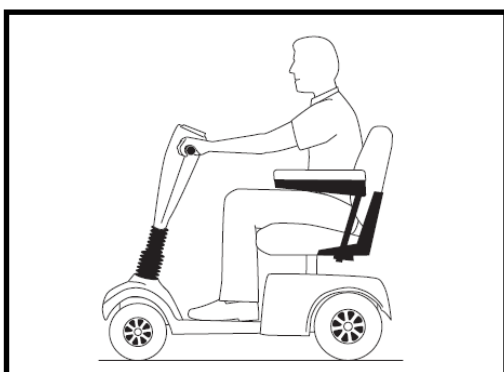

Figure 2: Normal Driving Position

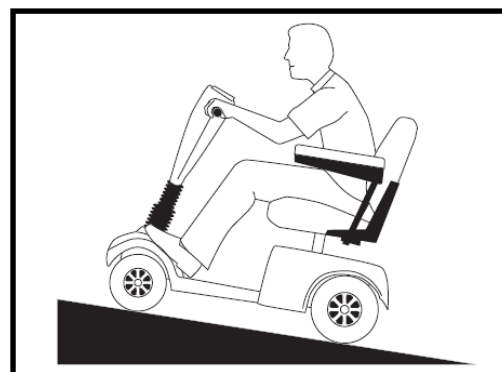

Figure 3: Increased Stability Drive Position

NOTE: If the throttle control lever is released while you are moving forward up a ramp, the GATSBY may roll back approximately 300 mm (12”) before the brake engages. If the throttle control lever is released while you are moving in reverse, the GATSBY may roll back approximately 1000 mm (39”) before the brake engages. If needed, you can use the handbrake for a shorter stop.

CORNERING INFORMATION

Excessively high cornering speeds can result in tipping. Factors that affect the possibility of tipping include, but are not limited to, cornering speed, steering angle (how sharply you are turning), uneven road surfaces, inclined road surfaces, riding from an area of low traction to an area of high traction (such as passing from a grassy area to a paved area – especially at high speed while turning), and abrupt changes of direction. High cornering speeds are not recommended. If you feel that you may tip over in a corner, reduce your speed and steering angle (i.e., lessen the sharpness of the turn) to prevent your **GATSBY** from tipping.

WARNING! When cornering sharply, reduce your speed and maintain a stable centre of gravity. When using your **GATSBY** at higher speeds, do not corner sharply. This greatly reduces the possibility of a tip or fall. Always exercise your common sense when cornering.

BRAKING INFORMATION

Your **GATSBY** scooter is equipped with powerful braking systems:

- ✓ **Regenerative:** Uses electricity to rapidly slow the vehicle when the throttle control lever returns to the centre/stop position.
- ✓ **Park Brake:** Activates automatically after regenerative braking slows the vehicle to a near stop, or when power is removed from the system for any reason.
- ✓ **Handbrake:** Manually activated when an immediate stop is required or if the scooter has stopped in an incline position in order to avoid a roll back effect.

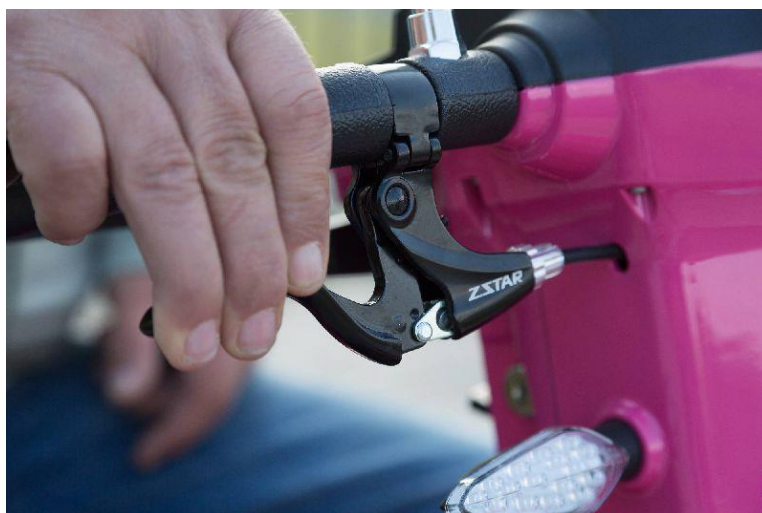

Figure 4: Handbrake

OUTDOOR DRIVING SURFACES

- ✓ Your **GATSBY** is designed to provide optimum stability under normal driving conditions, on dry, level surfaces of concrete, tarmac, or asphalt. However, we recognize that there will be times when you will encounter other surfaces. For this reason, your **GATSBY** is designed to perform well on packed soil, grass, and gravel. Feel free to use your **GATSBY** safely on lawns and in parks.
- ✓ Reduce your **GATSBY** speed when driving on uneven terrain and/or soft surfaces.
- ✓ Avoid tall grass that can become tangled in the running gear.
- ✓ Avoid loosely packed gravel and sand.
- ✓ If you feel unsure about a driving surface, avoid it.

PUBLIC STREETS AND ROADWAYS

WARNING! Do not operate your GATSBY on public streets or roadways. It may be difficult for traffic to see you when you are seated on your **GATSBY**. Obey all local pedestrian traffic rules. Wait until your path is clear of traffic, and then proceed with extreme caution.

STATIONARY OBSTACLES (STEPS, CURBS, ETC.)



WARNING! Do not drive near raised surfaces, unprotected ledges, and/or drop-offs (curbs, porches, stairs, etc.).

WARNING! Do not try to go up or down an obstacle that is too high.

WARNING! Do not try to go backward down any step, curb, or other obstacle. This may cause the GATSBY to tip.

WARNING! Be sure your GATSBY scooter is travelling perpendicular to any curb you may be required to go up or down.

WARNING! Do not attempt to negotiate a curb that is higher than 50 mm (2").

PRECAUTIONS DURING INCLEMENT WEATHER

Avoid exposing your **GATSBY** scooter to inclement weather.

If you are suddenly caught up in rain, snow, severe cold or heat while operating your **GATSBY**, proceed to shelter at the earliest opportunity. Thoroughly dry your **GATSBY** before storing, charging, or operating it.

PROHIBITED! Do not operate your GATSBY in rain, snow, salt, mist/spray conditions, or on icy slippery surfaces, as this can have an adverse effect on the electrical system. Maintain and store your GATSBY in dry and clean conditions.

WARNING! Prolonged exposure to extreme hot or cold may affect the temperature of parts of the GATSBY, possibly resulting in burns. Exercise caution when using your GATSBY in extremely hot or cold conditions or when exposing your GATSBY to direct sunlight for prolonged periods of time.

FREEWHEEL MODE

MANUAL FREEWHEEL MODE



Your **GATSBY** is equipped with a **manual freewheel lever** that, when pushed forward releases the electromagnetic brakes. This function allows moving the scooter manually.

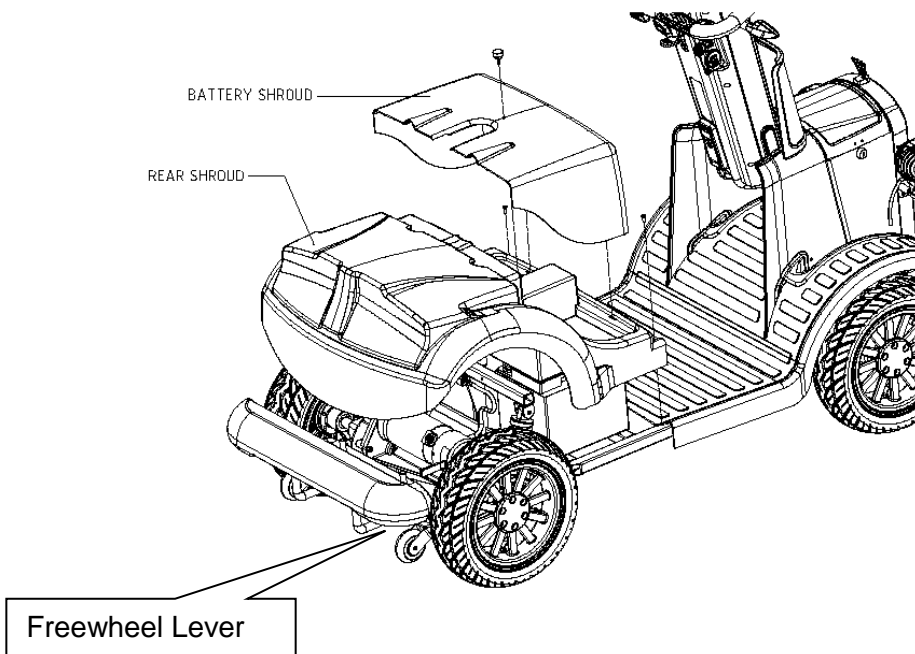

Figure 5: Manual Freewheel Lever

ELECTRICAL FREEWHEEL MODE

Your **GATSBY** is also equipped with an **electric button** located on the dashboard to release the electromagnetic brake. Turn the key-switch to ON position. To release the brake push the button and hold. To release the freewheel mode just release the button. This function allows moving scooter manually.



Electric button to release the electromagnetic brake

Figure 6: Electric button for Freewheel mode

WARNING! When your GATSBY is in freewheel mode, the parking system is disengaged.

WARNING! Do not press the automatic freewheel button while the GATSBY is driving

- ✓ Disengage the drive motors only on a level surface.
- ✓ Stand beside the **GATSBY** to engage or disengage freewheel mode. Never do this while sitting on the **GATSBY**.
- ✓ After you have finished pushing your **GATSBY**, always return it to the drive mode to lock the brakes (pull the manual freewheel lever backward).
- ✓ When using the freewheel lever, be careful **not to touch** the internal surface of the motor, as it could be very hot and cause injury. See the following warning label at the rear of the scooter near the lever.



STAIRS AND ESCALATORS

GATSBY scooters are not designed to travel up or down stairs or escalators. Always use an elevator.

WARNING! Do not use your GATSBY scooter to negotiate stairs or escalators.

DOORS

- ✓ Determine whether the door opens toward or away from you.
- ✓ Use your hand to turn the knob or to push the handle or push-bar.
- ✓ If the door opens away from you, drive your **GATSBY** gently and slowly forward to push the door open.
- ✓ If the door opens towards you, drive your **GATSBY** gently and slowly backwards to pull the door open.

CORRIDORS

The minimum width of corridor in which the scooter can be turned to face the opposite direction should be 2600 mm.

ELEVATORS

Modern elevators have a safety mechanism on the edge of the door that, when pushed, reopens the door(s).

- ✓ If you are in the doorway of an elevator when the door(s) begin to close, push on the rubber door edge or allow the rubber door edge to contact the **GATSBY** and the door will reopen.
- ✓ Take care that handbags, packages, or **GATSBY** accessories do not become caught in elevator doors.

NOTE: *Sometimes manoeuvring your GATSBY may be difficult in elevators and building entrances. Use caution when attempting to manoeuvre your **GATSBY** in small spaces, and avoid areas that might pose a problem.*

LIFTS /ELEVATION PRODUCTS

If you travel with your **GATSBY**, you may find it necessary to use a lift or elevation product to aid in transportation. We recommend that you closely review the manufacturer's instructions, specifications, and safety information before using the lift/elevation product.

WARNING! Never sit on your **GATSBY** when it is being used with any type of lift/elevation product. Your **GATSBY** was not designed for such use, and any damage or injury resulting from such use is not our responsibility.

BATTERIES (see also Storage and Specification Instructions)

GATSBY contains two lead-acid sealed batteries.



Figure 7: Batteries and battery connections



In addition to all Warnings below, be sure to comply with all battery handling information.



MANDATORY! Battery posts, terminals, and rated accessories contain lead and lead compounds. Wear goggles and gloves when handling batteries. Wash hands immediately after handling batteries.

WARNING! Scooter batteries are heavy. If you are unable to lift that much weight, be sure to get help. Use proper lifting techniques and avoid lifting beyond your capacity.

WARNING! Do not operate the scooter with depleted batteries.

WARNING! Always protect the batteries from freezing and never charge a frozen battery.

WARNING! Connect the battery cables correctly. RED (+) cables must be connected to positive (+) battery terminals/posts and BLACK (-) cables must be connected to negative (-) battery terminals /posts. REPLACE damaged cables immediately. Protective caps must be installed over all battery terminals.

NOTE: If the battery is damaged or cracked, immediately enclose it in a plastic bag and contact your local waste disposal agency or authorized **GATSBY** dealer for instructions for disposal or for recycling (which we recommend).

Disposal and recycling: Contact your authorized dealer for information on proper disposal of your **GATSBY** and its packaging.

MOTOR VEHICLE TRANSPORTATION

The GATSBY scooter is not intended to be used as a seat in a motor vehicle.

WARNING! Do not sit on your GATSBY while it is in a moving vehicle.



Figure 7 – Symbol for prohibition not intended to be used as a seat in a motor vehicle

The **GATSBY** should be stowed in the car or in the back of a truck or van with the batteries removed and properly secured. In addition, all removable parts, including the armrests, seat, and shroud, should be removed and/or properly secured during transportation.

WARNING! Although your GATSBY scooter may be equipped with an optional tie-down belt, this belt is not designed to provide restraint during motor vehicle transportation. Anyone travelling in a motor vehicle must be properly secured in the motor vehicle seat with securely fastened seat belts.

WARNING! Always be sure that GATSBY and its batteries are properly secured when it is being transported. Batteries must be secured in an upright position, and protective caps must be installed on the battery terminals. Batteries must not be transported with any flammable or combustible items.

PREVENTING UNINTENDED MOVE OF THE SCOOTER

WARNING! If you anticipate being stationary for an extended period of time, turn off the power. This will prevent unintended move caused by accidentally touching the throttle control lever.

GETTING ONTO AND OFF YOUR GATSBY



Getting onto and off your **GATSBY** requires a good sense of balance. Please observe the following safety tips when getting on and off your **GATSBY**:

- ✓ Remove the key from the key switch.
- ✓ Ensure that your **GATSBY** is not in freewheel mode
- ✓ Ensure that the seat is secured in place.
- ✓ Pivot the armrests up.

WARNING! Position yourself as far back as possible in the seat to prevent the GATSBY from tipping and causing injury.

WARNING! Avoid putting all of your weight on the armrests, and do not make the armrests bear weight, such as during transfers. Such use may cause the GATSBY to tip, resulting in a fall from the GATSBY and/or personal injury.

WARNING! Avoid putting all of your weight on the floorboard. Such use may cause the GATSBY to tip.

REACHING AND BENDING

Avoid reaching or bending while driving your **GATSBY**. Bending forward creates the risk of accidentally contacting the throttle control lever. Bending to the side while seated creates the risk of tipping. It is important to maintain a stable centre of gravity to keep the **GATSBY** from tipping. We recommend that you determine your personal limitations and practice bending and reaching in the presence of a qualified attendant.

WARNING! Do not bend, lean, or reach for objects if you have to pick them up from the GATSBY deck or from either side of the GATSBY. Movements such as these may change your centre of gravity and the weight distribution of the GATSBY, causing it to tip.

PROHIBITED! Keep your hands away from the tires and wheels when driving. Be aware that loose-fitting clothing can become caught in tires and wheels.

PRESCRIPTION DRUGS / PHYSICAL LIMITATIONS

The **GATSBY** user must exercise care and common sense when operating the **GATSBY**. This includes awareness of safety issues when taking prescription or over-the-counter drugs or when the user has specific physical limitations.

WARNING! Consult your physician if you are taking prescription or over-the-counter medication or if you have certain physical or cognitive limitations. Some medications and limitations may impair your ability to operate your GATSBY in a safe manner.

SMOKING

WARNING! The manufacturer strongly recommends that you do not smoke while seated on your GATSBY, although the GATSBY seat has passed the necessary testing requirements for cigarette smoking.

You must adhere to the following safety guidelines if you decide to smoke cigarettes while seated on your **GATSBY**:

- ✓ Do not smoke while driving.
- ✓ Do not leave lit cigarettes unattended.
- ✓ Keep ashtrays a safe distance from the seat cushions.
- ✓ Always make sure cigarettes are completely extinguished before disposal.

ALCOHOL

WARNING! Do not operate your GATSBY while you are under the influence of alcohol, as this may impair your ability to operate the GATSBY in a safe manner.

5. EMI / RFI WARNINGS

Electromagnetic Interference / Radio Frequency Interference



All types of electrically powered vehicles, such as powered wheelchairs and motorized scooters (in this text all types will be referred to as “powered vehicles”) may be susceptible to Electromagnetic (EMI) and Radio Frequency waves (RFI). EMI/RFI can come from sources such as cellular phones, mobile two-way radios (such as walkie-talkies), radio stations, TV stations, amateur radio (HAM) transmitters, wireless computer links, microwave signals, paging transmitters and medium- range mobile transceivers used by emergency vehicles. In some cases, they can cause unintended movement or damage to the control system.

The interference (from radio wave sources) can cause the powered vehicle to release its brakes, move by itself, or move in unintended direction. It can also damage the powered vehicle’s control system. The intensity of the interfering EM energy can be measured in volts per meter (V/m). Each powered vehicle can resist EMI interfering electromagnetic energy (EM) emitted up to a certain intensity. This is called its “immunity level”.

The higher the immunity level, the greater is the protection. At this time, current technology is capable of achieving an immunity level that would provide useful protection from the more common sources of radiated EMI. This vehicle as shipped, with no further modification, has an immunity level of 20 V/m.

There are a number of sources of relatively intense electromagnetic fields in the everyday environment. Some of these sources are obvious and easy to avoid. Others are not apparent and exposure is unavoidable. However, we believe that by following the warning listed below, your risk of EMI/RFI will be minimized:

The sources of radiated EMI/RFI can be broadly classified into three types:

1. Hand-held portable transceivers (transmitters-receivers) with the antenna mounted directly on the transmitting unit. Examples include: citizen band (CB) radios, “walkie talkies”, security, fire and police transceivers, cellular telephones and other personal communication devices.
NOTE: Some cellular telephones and similar devices transmit signals while they are turned ON, even when not being used.
2. Medium-range mobile transceivers such as those used in police cars, fire trucks, ambulances and taxis. These usually have the antenna mounted on the outside of the vehicle.
3. Long-range transmitters and transceivers such as commercial broadcast transmitters (radio and TV broadcast antenna towers) and amateur (HAM) radios.

NOTE: *Other types of hand held devices, such as cordless phones, laptop computers, AM/FM radios, TV sets, CDplayers, cassette players and small appliances such as electric shavers and hair dryers, as far as we know, are not likely to cause EMI problems to your powered vehicle.*

WARNING! The addition of accessories or components to an electrically powered mobility vehicle can increase its susceptibility to EMI. Do not modify your GATSBY scooter in any way not authorized by the manufacturer.

WARNING! The GATSBY itself can interfere with other electrical devices located nearby, such as alarm systems.

POWERED VEHICLE Electromagnetic Interference (EMI)

Because EM energy rapidly becomes more intense as one move closer to the transmitting antenna, the EM field from hand-held radio wave sources (transceivers) are of special concern. It is possible to unintentionally bring high levels of EM energy close to the powered vehicle's control system while using these devices. This can affect powered vehicle movement and braking.

Therefore, the warnings listed below are recommended to prevent possible interference with the control system of the powered vehicle:

WARNINGS

Electromagnetic interference (EMI) from sources such as radio and TV stations, amateur radio (HAM) transmitters, two-way radios and cellular phones can affect powered vehicles.

Following the warnings listed below should reduce the chance of unintended brake release or powered vehicle movement which could result in serious injury:

WARNINGS!

- 1) Do not operate hand-held transceivers (transmitters-receivers) such as citizen band (CB) radios, or turn ON personal communication devices such as cellular phones, while the powered vehicle is ON**
- 2) Be aware of nearby transmitters, such as radio or TV stations and try to avoid coming close to them.**
- 3) On appearance of unintended movements or brake release occurrences, switch the powered vehicle OFF as soon as it is safe to do so. You can use, if necessary the handbrake to manually stop the scooter.**
- 4) Be aware that adding accessories or components, or modifying the powered vehicle, may make it more susceptible to EMI (since there is no easy way to evaluate their effect on the overall immunity level of the powered vehicle).**
- 5) Please report to us all incidents of unintended movement or brake release and note whether there is a source of EMI nearby.**

Important information

- 1) 20 volts per meter (V/m) is a generally achievable and useful immunity level against EMI (as of May 1994). The higher the level the greater the protection;
- 2) This product delivered to you has an immunity level of 20 V/m.

6. CHARGING THE BATTERIES

Read the Charger instructions before using it.

WARNING: If you use a charger other than the one supplied with your GATSBY ask your dealer for instructions.

CHARGING BATTERIES (see Figure 8)

1. Insert the Charger plug in the charging socket located on the right side of the tiller column.
 2. Plug the Charger power cord into a wall socket.
 3. When charging is complete, remove the Charger power cord from the wall socket and then remove the charger plug from the charging socket.
 4. Under ideal storage conditions, batteries that were charged to full capacity and were not used should be recharged every month. Recommended charging time is two days. After recharging disconnect the batteries.
 6. If you have not used your **GATSBY** for an extended period of time, charge the batteries for at least 24 hours before driving.
- NOTE: There is NO need to disconnect the charging plug immediately after the charging is complete.
 - DO NOT leave the Charger connected to the batteries FOR MORE THAN TWO WEEKS.
 - As long as the charging plug is in the charging socket, the electronic control of the GATSBY automatically cuts all power to the electric system and it cannot be driven.
 - The Charger supplied is suitable for charging lead acid dry/gel batteries. Use only the defined type of charger. Before using any other type of Charger, check with your dealer.

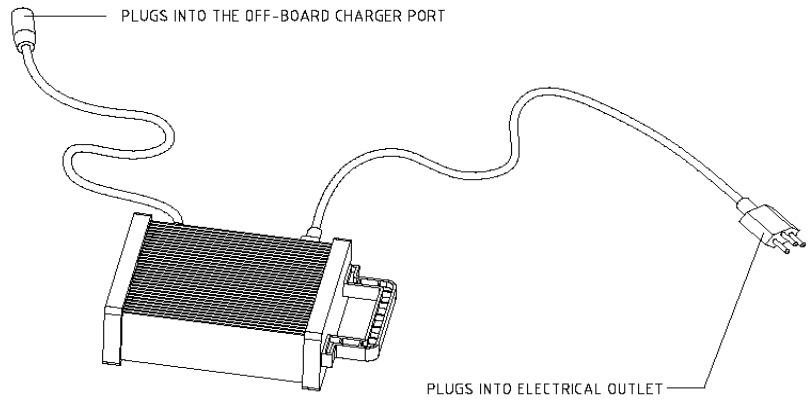

Figure 8: Battery Charger

Electrical System Fuses

Your GATSBY scooter is equipped with a series of electrical system fuses, which help protect the off-board charging system, key switch, and lighting system from receiving an overload of electrical current. These fuses are the same type used in automobiles and are located in a compartment on the tiller (see figure 9).

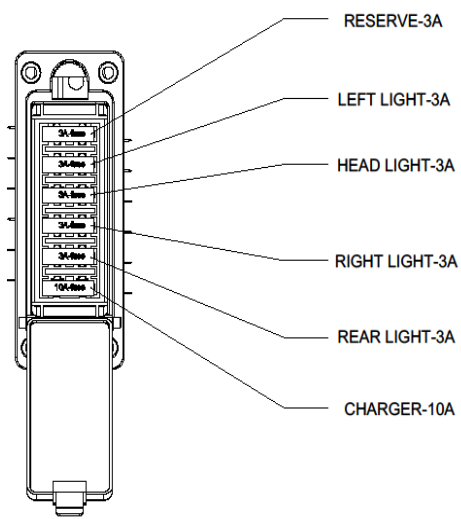

Figure 9: Electrical system fuses

7. ADJUSTMENTS INTRUCTIONS

TILLER ADJUSTMENT LEVER

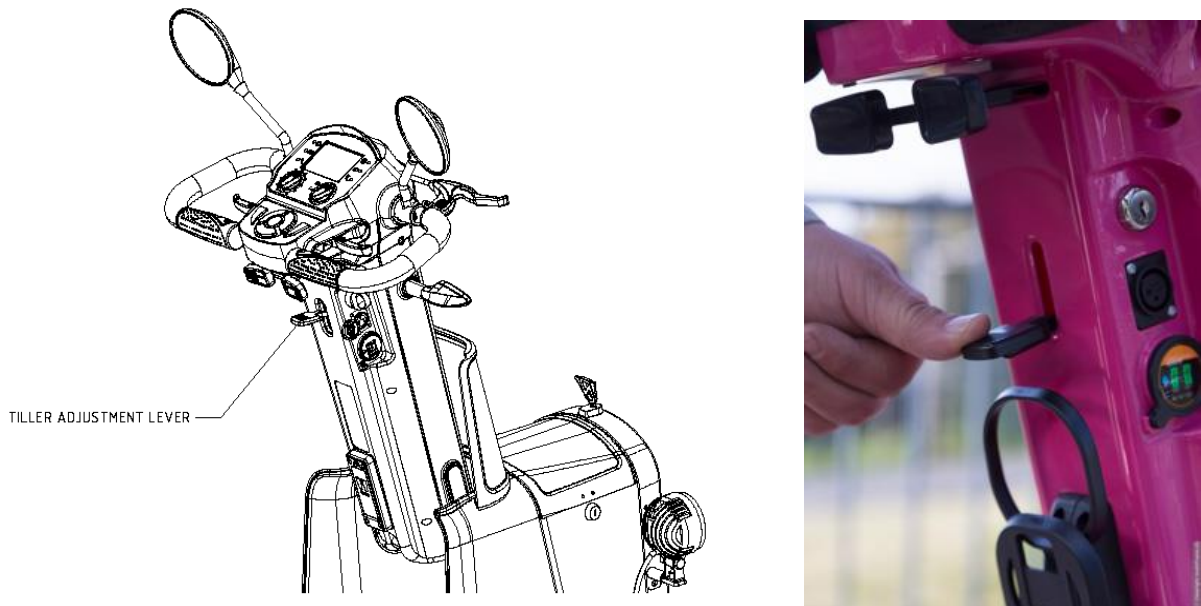

Figure 10: Tiller adjustment

WARNING!

**Remove the key from the key switch before adjusting the tiller or the seat.
Do not attempt to adjust the tiller or the seat while the scooter is in motion.**

You can adjust the tiller to many positions. The tiller adjustment lever locks the tiller in place. It has a spring-loaded mechanism that enables you to rotate the tiller and change its position.

To change the tiller angle:

1. Squeeze the tiller adjustment lever. See figure 8.
2. Move the tiller to a comfortable position.
3. Release the tiller adjustment lever to lock the tiller into place.

NOTE: In order to fully lower the tiller for purposes of disassembly or transport, you must first completely remove the seat. See A2: "Disassembly and Assembly".

MIRROR INSTALLATION

To install the mirror (see figure 9 below):

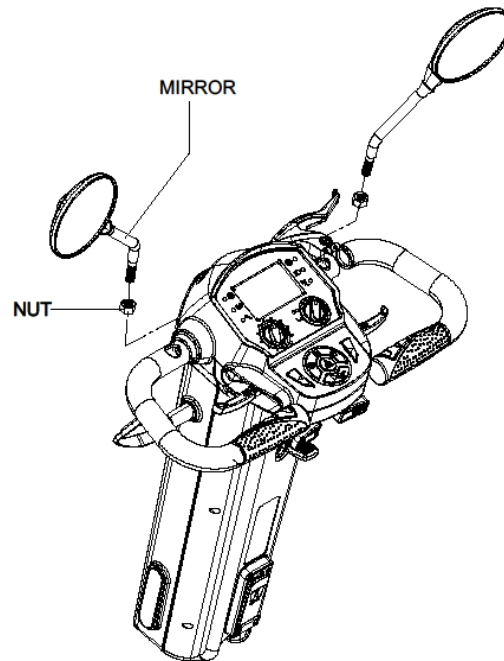

Figure 11: Mirror installation



1. Determine on which side to install the mirror and remove the rubber plug from the top of the tiller handle.
2. Insert the threaded end of the mirror holder into the opening and rotate it clockwise until snug.
3. If necessary, rotate the nut clockwise to secure the mirror in place.

To adjust the mirror:

1. Position yourself in a seated driving position facing forward.
2. Adjust the mirror left, right, up, or down until you have a good line of sight behind you.

SEAT ADJUSTMENTS

WARNING! Do not operate your scooter with the seatback in a reclined position.

WARNING! Always keep your back pressed firmly against the seatback while adjusting the angle.

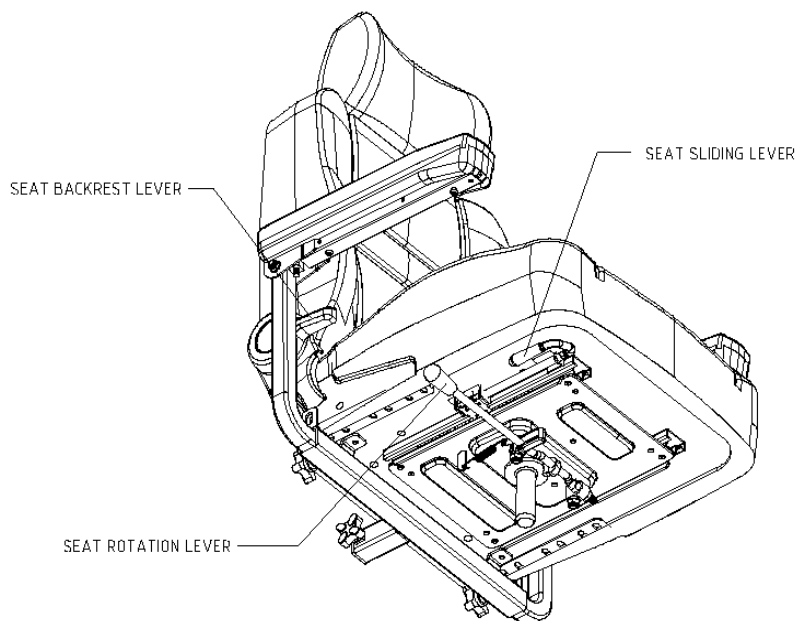

Figure 12: Seat adjustments (seen from below)

SEAT RECLINING ADJUSTMENT

1. With your back pressed up against the seatback, lift up on the seatback adjustment lever and lean forward or rearward to adjust the seatback angle.
2. Release the seatback adjustment lever once the seat is in a comfortable riding position.



Seat backrest
lever

Figure 13: Seat backrest adjustment lever

SEAT ROTATION ADJUSTMENT

The seat rotation lever will secure the seat into several positions.

1. Push forward on the seat rotation lever to disengage the seat
2. Rotate the seat to the desired position.
3. Release the lever to secure the seat into place.



Figure 14: Seat rotation and front-to-back adjustment levers

FRONT-TO-BACK SEAT ADJUSTMENT (Figure 14)

You can reposition the seat forward or rearward to adjust the distance between the seat and the tiller:

1. Move the seat sliding lever located at the lower left side of the seat outward
2. While holding the lever out, slide the seat forward or rearward.
3. Release the seat sliding lever once the seat is in the desired position.

SEAT HEIGHT ADJUSTMENT (Figure 15)

The **GATSBY** seat can be adjusted to different heights. To reposition the scooter seat height proceed as follows:

1. Remove the seat and the shroud above the batteries.(see also Appendix A2)
2. Remove the seat height adjustment bolt.
3. Raise or lower the upper seat post to the desired seat height.
4. While holding the upper seat post at that height, match up the locating holes in the upper seat post with those of the lower seat post.
5. Insert the seat height adjustment bolt through the locating holes of both the upper and lower seat posts.
6. Reinstall the nut onto the seat height adjustment bolt and tighten.

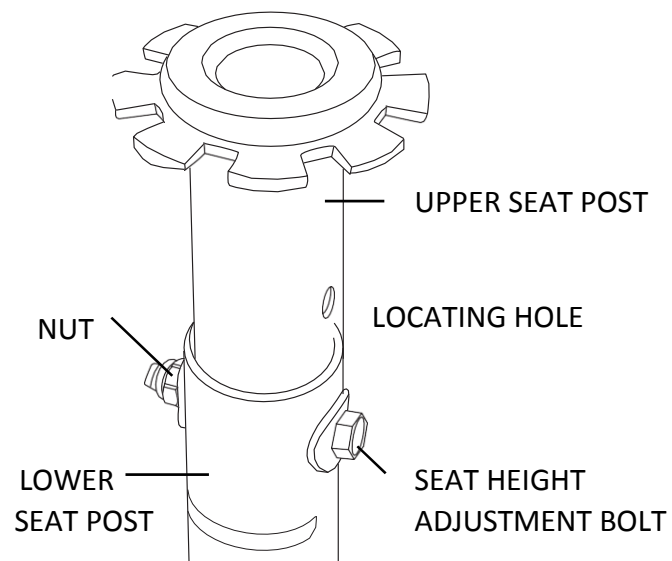

Figure 15: Seat height adjustment



WARNING! Do not lift beyond your physical capability. Ask for assistance when necessary for adjusting the seat height of your scooter.

8. OPERATION

WARNING! Do not operate the scooter with depleted batteries.

WARNING! Do not operate the scooter when behaving abnormally.

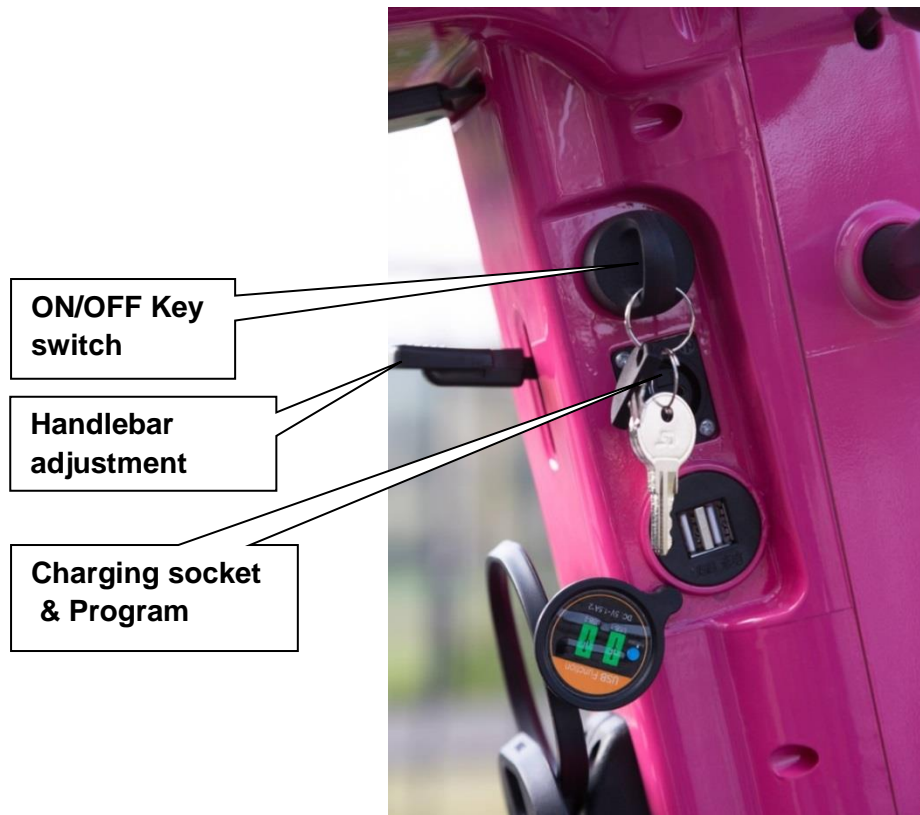
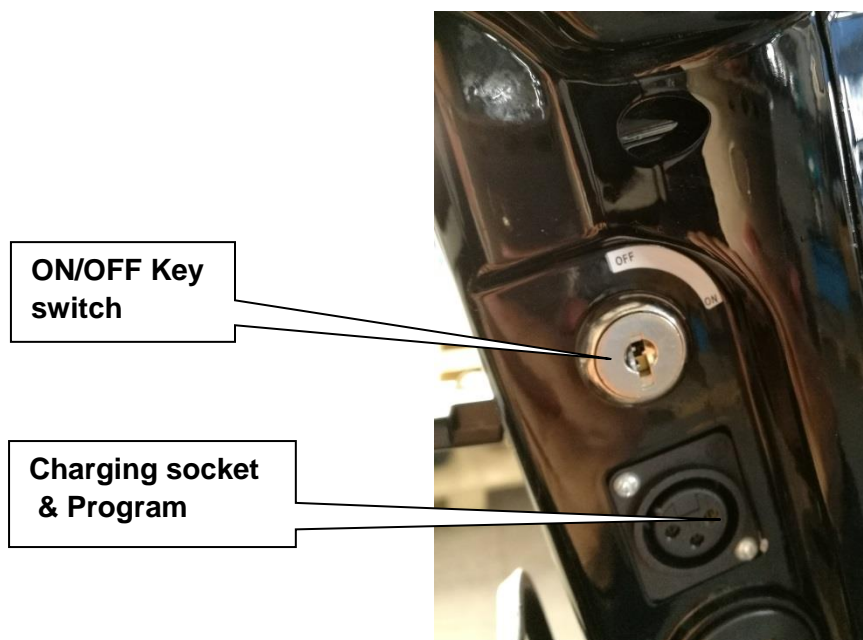

Figure 16: ON/OFF Switch – Charging socket



Explanations to Figure 16

ON/OFF Key Switch	<ul style="list-style-type: none">• The main key switch is located on side of tiller column• The key switch has two positions• OFF: The GATSBY cannot be driven and the EMB is locked.• ON: Power is supplied to the GATSBY and the EMB is released automatically when the throttle control lever is squeezed. <p>To operate the GATSBY, insert the key in the key switch and turn it to ON (clockwise). The switch will remain in this position and the Power indicator will be lit.</p> <p>NOTE: The key switch is used to operate the GATSBY, not for locking</p>
Handlebar Adjustment Lever	<p>Adjust the position of the handlebars (height and distance) as follows:</p> <ol style="list-style-type: none">1. Push the handlebar adjustment lever (which locks the handlebars in place), and move the handlebars to the position
Charging Socket	<p>Before attempting to drive the GATSBY, make sure the plug is disconnected from the charging socket.</p> <p>NOTE: While the plug is in the charging socket, the GATSBY cannot be operated.</p> <p>Insert the charger plug in the charging socket located on the right side of the tiller column to charge your scooter.</p> <p>IMPORTANT: Read Section 6 for more information regarding Charging Instructions.</p>

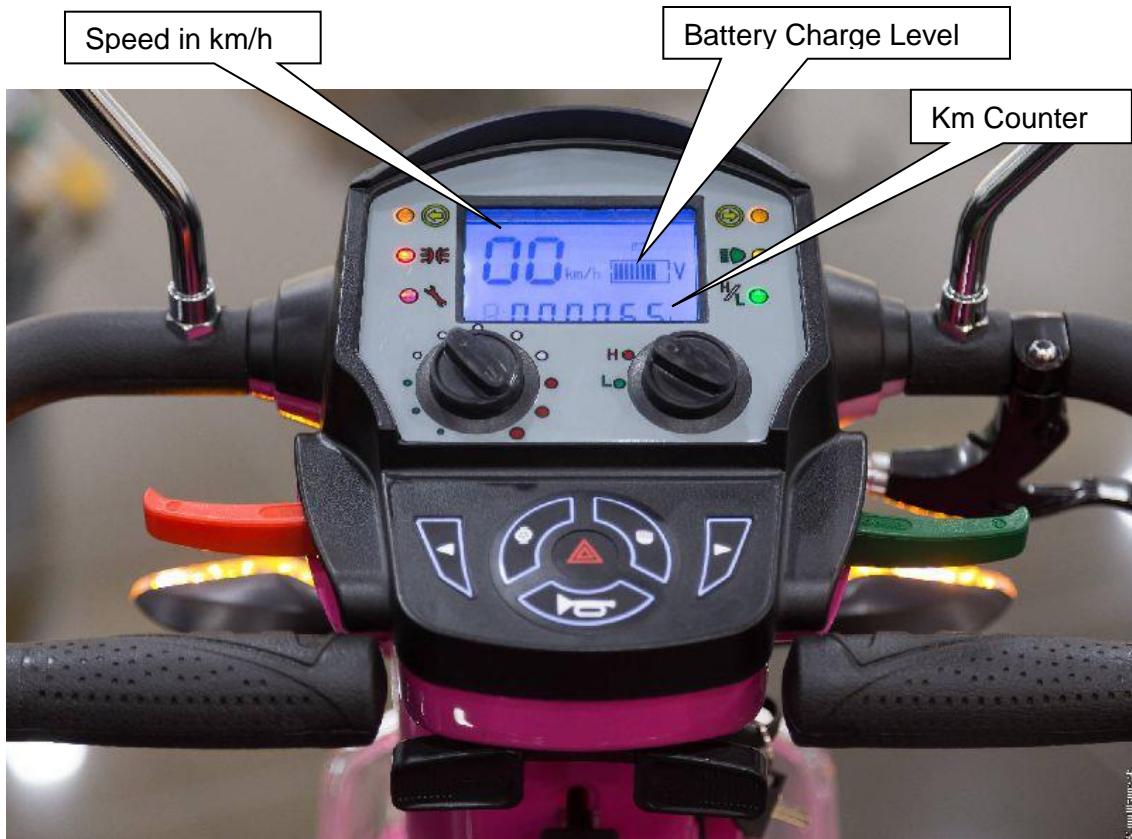

Figure 17a: Tiller Dashboard

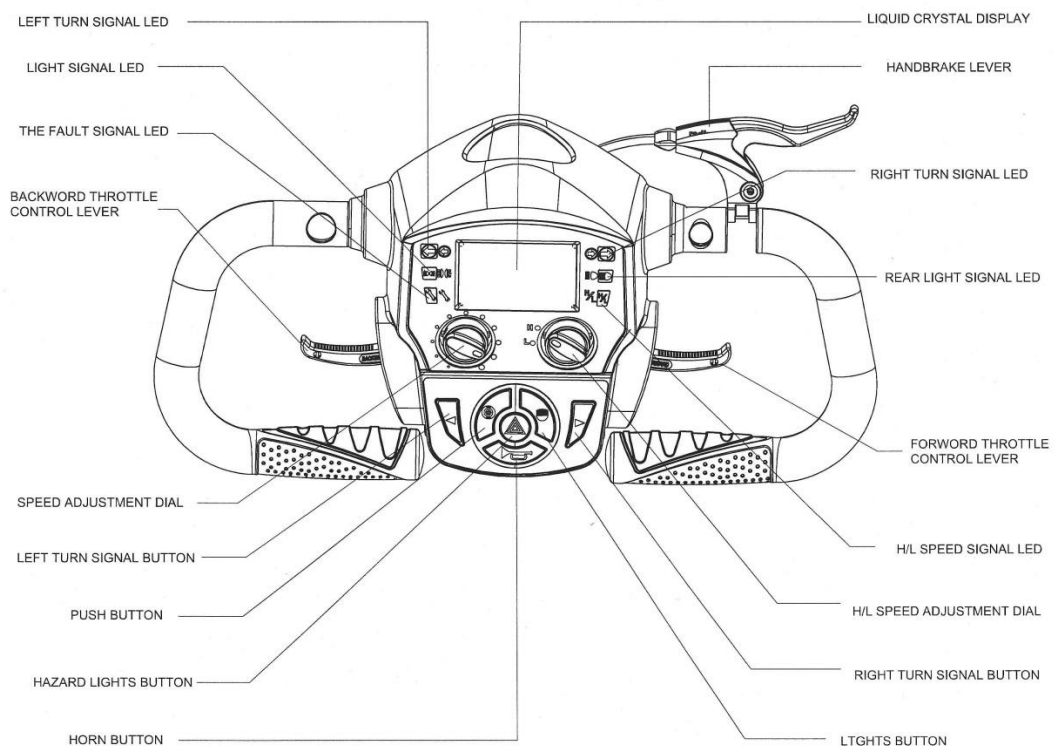

Figure 17b: Tiller Dashboard (Detail)

Explanations to Figure 17

<p>Speed Adjustment Dial</p>	<p>The speed adjustment dial is located on the handlebar panel.</p> <ul style="list-style-type: none"> • When the speed limit dial is set to MAX, the GATSBY will drive at approximately 15 km/h. • When the speed limit dial is set to MIN, the GATSBY will drive at approximately 3 km/h. <p>Do not change the speed limit dial setting while the GATSBY is moving.</p> <p>Note: <u>Set the speed limit dial to MIN:</u></p> <ul style="list-style-type: none"> • Until you get used to driving your new GATSBY, and • When driving the GATSBY inside a building or in a crowded area.
<p>High – Low Speed mode Switch</p>	<p>Set the maximum speed of the scooter to HIGH or LOW speed. Use the LOW speed mode when driving in close and crowded areas.</p>
<p>Throttle Control Lever</p>	<p>To drive: Gently squeeze the throttle control lever (depending on whether you want to drive forward or backward) until you reach the desired speed. The speed is directly proportional to the deflection of the throttle control lever.</p> <p>Note: You can squeeze one side of the throttle control lever towards you, or you can push the other side away from you to achieve the same effect. Throttle control selection can also be activated by fingers or thumb of both hands, use whichever method is most comfortable for you.</p> <p>To stop: Release the throttle control lever. The GATSBY will stop gradually.</p>
<p>Turning buttons</p> <p>Hazard button</p>	<p>Before you turn, press the applicable indicator button. When a turn indicator is activated, the applicable LED will flash. To turn off the indicator, press the button again.</p> <p>The Hazard button activates the hazard lights (front and rear blinkers). To turn off the hazard lights, press the button again.</p>
<p>Buzzer button</p> <p>Automatic Freewheel switch</p>	<p>To activate the buzzer, push the buzzer button.</p> <p>Turn the key switch to ON position. To activate push button and hold. To release the brake just leave the button. This function allowed moving scooter manually.</p> <p>WARNING! Do not press the automatic freewheel button while the GATSBY is moving.</p>
<p>Button for headlight and rear lights</p>	<p>To turn ON the lights (headlight and rear lights), press the Lights button. When the lights are on, the Light LED is lit. To turn OFF the lights, press the button again.</p>

After stopping	<p>After stopping the GATSBY, turn the key switch to OFF and remove the key. The ON LED will turn off.</p> <p>Note: The EMB (Electromagnetic Brake) locks automatically when the throttle control lever is released and the GATSBY has come to a complete stop.</p>
Safe driving	<p>When driving on ramps, high curbs and on sharp turns, drive very slowly and carefully, preferably with the speed set to MIN.</p> <p>When going up or down a step, always drive so that the wheels are fully perpendicular to the step and both of the rear wheels meet the step at the same time.</p> <p>Never try to go on an obstacle that is more than the maximum recommended slope or curb height (see the stabilities and the obstacle climbing specifications in Appendix A1).</p> <p>Always drive carefully and adjust your speed to the road conditions. Before making sharp turns, reduce speed to minimum to prevent side roll-over.</p>
Climbing an obstacle	<p>To climb an obstacle, drive the GATSBY forward toward the obstacle until the front wheel touches the obstacle, then, maintaining your direction, increase speed.</p>
Prior to use	<p>After reading through this entire manual and before using the GATSBY, do a visual check of all the parts of the vehicle, to make sure that there is no visible damage. If you have any questions or concerns, contact your dealer</p>
Controller programming	<p>Several parameters of the GATSBY controller can be programmed. Programming must be done by trained authorized technician only. Incorrect programming can cause abnormal operation of the GATSBY and may result in damage and personal injury.</p>
Prior to use	<p>Before using the GATSBY, be sure you know your own weight and the weight of any items you will be carrying on it. The maximum total load is 150kg (330lbs).</p>
Performance check	<p>A performance check is highly recommended when you first receive your GATSBY or after a period of not using it, as follows:</p> <ol style="list-style-type: none"> 1. Turn on the key switch. 2. Verify that both the ON LED and the battery status indicator are lit. 3. Slowly squeeze the drive control lever and verify that the GATSBY travels at a speed that corresponds to the degree to which you are squeezing the lever. 4. Release the throttle control lever and verify that the GATSBY stops smoothly, and that you hear the click of the EMB engaging. 5. Check that all the buttons on the dashboard work correctly. 6. Switch off the key switch. <p>Your GATSBY is now ready to drive.</p>

Battery status Indicator	<p>The battery status indicator is located on the tiller panel and shows you the remaining capacity of the batteries. Like petrol gauges in cars, the Indicator is not absolutely accurate; it is merely a guide to help you avoid running out of “fuel”. The accuracy of the indicator also depends on the type and age of the batteries.</p> <p>When the indicator shows 4 bars, recharge batteries as soon as possible.</p> <p>When the indicator shows 2 bars, recharge immediately.</p>
Maintenance LED	<p>When the LED is flashing, it blinks the code of the fault.</p>

9. CARE AND MAINTENANCE

Although the **GATSBY** requires very little maintenance, do not neglect it. When performing maintenance procedures on the **GATSBY**, make sure that it stands on a level surface and that the key is not inserted.

This chapter contains both, periodic maintenance procedures and maintenance procedures to be performed as required.

Periodic Maintenance Procedures

- ✓ **Remark:** For periodic maintenance, no special tools are needed.

No.	Type of Service	Frequency
1	Check for missing and damaged parts	When first receiving the GATSBY or after a long time without use
2	Check air pressure in all tires	Every two weeks (30 psi)
3	Replace batteries	<ul style="list-style-type: none"> ▪ Every 2-3 years ▪ When the distance you can travel on a single charge becomes short, or ▪ After a technician recommends replacing it
<p>Note: To replace the batteries, the seat and the battery cover (which is located under the seat) must be removed</p>		

Tires	Correct tyre pressure is essential for steering and stability. Check the tyre pressure every two weeks (30 psi)
Cleaning	Use only a damp cloth and mild detergent for cleaning. Never use a hose, as this may severely damage the power and electronic components

Replace batteries	<p>NOTE! Batteries must be replaced by trained professionals only.</p> <p>WARNING! Batteries contain high energy and can spark, resulting in a possible fire hazard.</p> <p>WARNING! Working with batteries can cause damage and Injury if not done properly. In this procedure, refer to Figure D bellow:</p> <ol style="list-style-type: none"> 1. Remove the terminal insulating cap from one battery terminal 2. Using an 8 mm key, unscrew the wiring from the terminal. Take care not to let the key touch any other terminal or metal part, as this could cause damage or injury 3. Repeat steps 1 and 2 for all the other terminals 4. Remove the old batteries and install the new ones 5. Connect the wires of the new batteries as shown in Figure bellow 6. Screw down the terminals securely, and replace the insulating caps
--------------------------	---

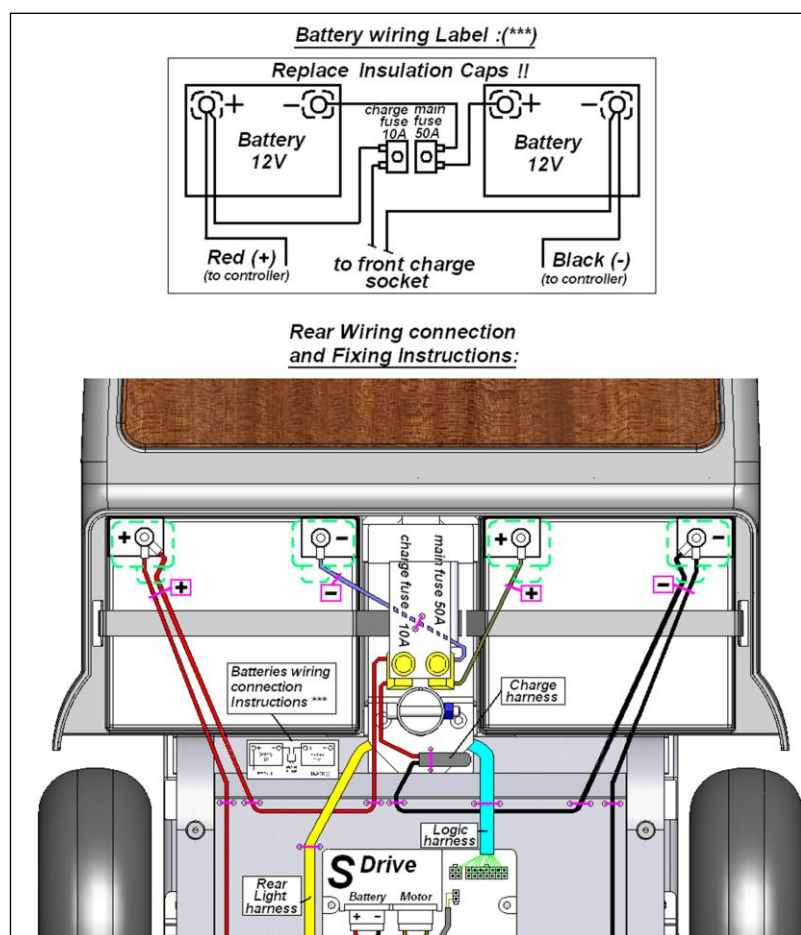

Figure 18: Battery position and connections

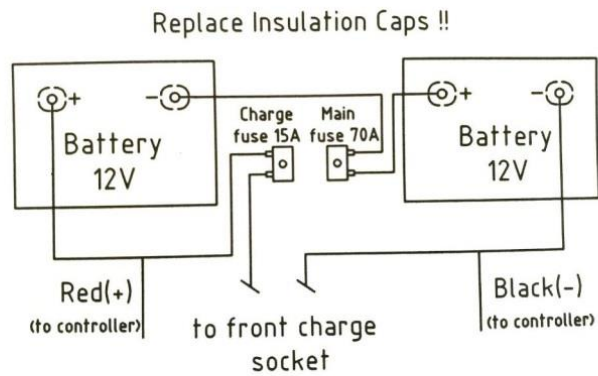

Figure 19: Battery wiring

- **Expected Service Life:** 5 years depending on usage. After this period the scooter may need to undergo a major service or be replaced.

10. TROUBLESHOOTING AND REPAIR

The following table provides troubleshooting and repair instructions for problems that may be encountered when operating the **GATSBY**. as well as the best way to correct the problem. The table contains three columns:

Symptom	Probable Cause	Remedy
The problem you are experiencing	The most likely causes, in order of probability (most likely first)	Recommended action to correct each probable cause

Note: you can contact your dealer at any time for further professional support. The manufacturer – Rehabilitations-Systeme AG – has authorized service facilities and has replacement units available when needed.

Replacement parts:

- Tires and tubes are: 330 mm x101.6 mm, (13"x4")
- Rear + Front LED light : contact your authorized dealer.

No.	Symptom	Probable Causes	Remedy
1	Flat tire and unstable driving	<ul style="list-style-type: none"> ✓ Low air pressure ✓ Puncture 	<ul style="list-style-type: none"> ✓ Pump tyre to normal pressure ✓ Repair tyre
2	When throttle control lever is released on a level surface, the GATSBY takes longer than 3 meters to stop	<ul style="list-style-type: none"> ✓ Controller is faulty or out of adjustment 	<ul style="list-style-type: none"> ✓ Call for technical support
3	Key switch is turned ON but the ON light does not come on	<ul style="list-style-type: none"> ✓ Main fuse (in Figure D) popped ✓ Electrical fault 	<ul style="list-style-type: none"> ✓ Reset fuse <p>Note: Do not reset fuse more than twice. If the symptom still recurs, call your authorized dealer for support</p>
4	GATSBY does not move when you squeeze the throttle control lever	<ul style="list-style-type: none"> ✓ Key switch is OFF ✓ Charger is connected to charging socket ✓ Control system failure 	<ul style="list-style-type: none"> ✓ Turnkey switch ON ✓ Disconnect charger ✓ Call for technical support
5	Intermittent drive.	<ul style="list-style-type: none"> ✓ Battery capacity is low ✓ Faulty connections ✓ Faulty battery 	<ul style="list-style-type: none"> ✓ Charge batteries for at least 18 hours ✓ Remove battery cover and check battery connection. If terminals are corroded, clean them with a damp, clean cloth ✓ If red LEDs are still on, contact your dealer for a replacement battery
6	Right or left indicator light is inoperative.	<ul style="list-style-type: none"> ✓ Faulty LED light board 	<ul style="list-style-type: none"> ✓ Replace LED board
7	Headlight or rear light not lit.	<ul style="list-style-type: none"> ✓ Burnt out LED 	<ul style="list-style-type: none"> ✓ Replace LED
8	When driving uphill or carrying heavy loads, speed reduces gradually (but scooter still moves).	<ul style="list-style-type: none"> ✓ Controller became overheated 	<ul style="list-style-type: none"> ✓ Stop driving and let controller cool

TIRE PUNCTURE

The Gatsby scooter is equipped with pneumatic tires. In case of a flat tire due to puncture the tube will have to be replaced.

WARNING! Wheels on your Gatsby scooter should only be serviced or replaced by authorized Rehasys provider or qualified technician.

WARNING! Completely deflate the tires before attempting repair.

Following these steps to remove the tire and replace the tube:

1. Remove the key from the key switch
2. Elevate the side of the scooter of which you are removing the tire. Fix the scooter at elevated position by placing e.g. wooden blocks under the frame
3. Remove the lug nuts
4. Pull the wheel off the axle (Figure 20)

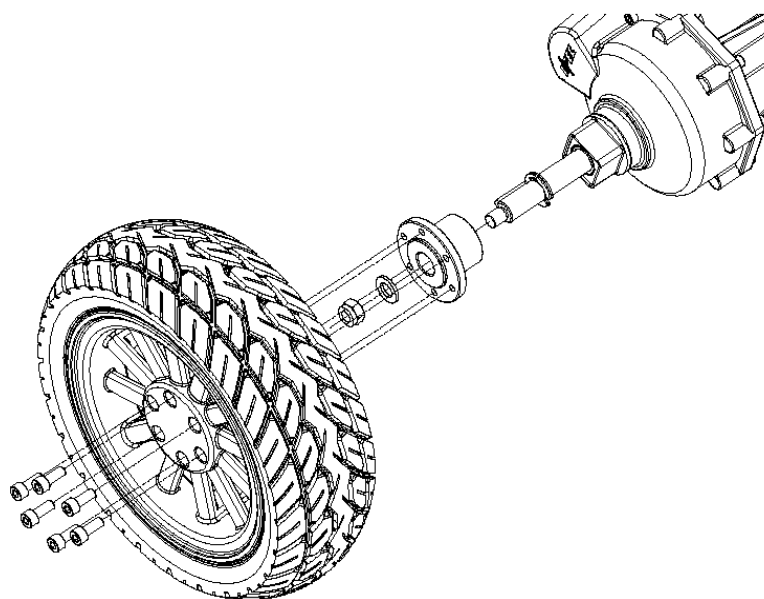

Figure 20: Removal of the wheel

5. Take the two rims apart and remove the tube (Figure 21).
6. Replace the tube
7. Push the two rims together
8. Slide the wheel onto the axle
9. Reinstall the lug nuts and tight them properly
10. Inflate the tire to the right pressure (2.07bar / 30psi)
11. Remove the blocks from beneath the scooter

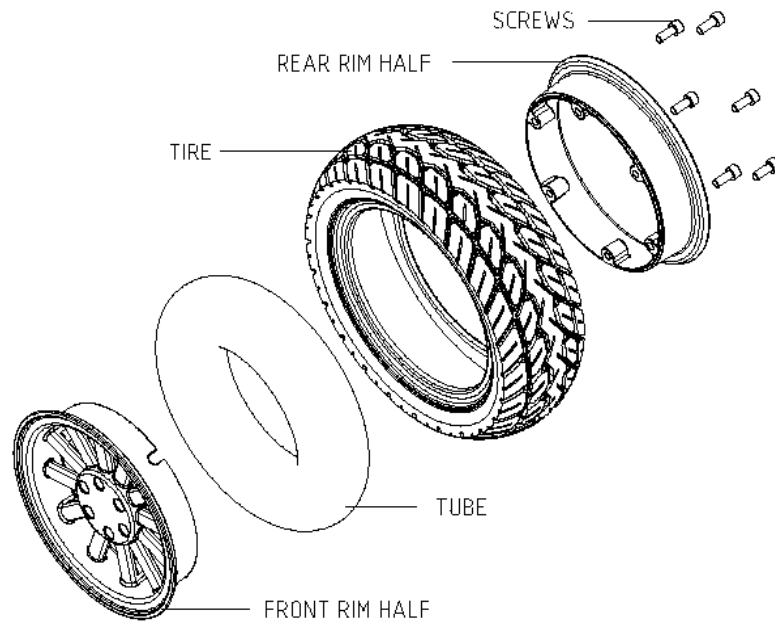

Figure 21: Replacing the tire tube

11. WARRANTY

TWO-YEAR LIMITED WARRANTY

- Gearbox
- Motor

ONE-YEAR LIMITED WARRANTY

- Bearings
- Bushings
- Rubber Components
- Plastic components (except body)
- Electronic Controllers
- Charger
- Harnesses
- Any other electrical subassembly
- Batteries

WARRANTY EXCLUSIONS

This warranty does not extend to those items which may require replacement due to normal wear and tear.

- Plastic shrouds
- Motor brushes
- Upholstery and seating
- Brake pads
- Tires and tubes
- Fuses / Bulbs

WARRANTY SERVICE

Warranty service must be performed by an authorized Vintage Mobility dealer. Please contact your authorized Vintage Mobility dealer for more information.

There is no other express warranty

A1. SPECIFICATIONS

Technical Data

- Maximum forward speed 15 km/h . . . (9.32 mph)
- Maximum backward speed ¹ 5 km/h ¹ . . . (3.11 mph) ¹
- Maximum Safe Climbing Grade 8° (10%)
- Range with Full Charge ² 40 km ² (28 miles) ²
- Turning radius ³ 1940 mm ³ . . . (75.5") ³
- Ground clearance 100 mm (3.94")
- Max. obstacle climbing ability 50 mm (2")
- Scooter weight w/o batteries 80 kg (176.4 lbs)
- Load Capacity (max) 150 kg (332 lbs)
- Length 1550 mm (61")
- Width 665 mm (26.2")
- Height 1300 mm . . . (31.2")
- Seat width 460 mm (18.1")
- Seat height 750 mm . . . (29.53")
- Seat weight 23 kg (50 lbs)
- Tires size 330 x101.6 mm². . (13"x4")
- Tire type Pneumatic
- Tires pressure 2.07 bar (30 psi)

Electronic Controller

- Type S-Drive Controller, 120 Amp (PG Drives Technology)

Batteries

- Quantity..... Two pieces
- Type 12 VDC / 55 Ah
- Weight 45 kg (99.2 lbs)

Battery Charger

- Input 120 V/AC - (US) Output 24 VDC / 8 A
- Input 230 V/AC - (EU) Output 24 VDC / 8 A

Motor

- Motor Power 950 W - 24 VDC

Breaking Type

- Dual Brake System Regenerative and Electromechanical
- Hand brake Mechanical

Classification

- Europe Class 1 Medical Device
- FDA (USA) Class II, (Prod. Code: INI, 890.380)
- Type Class Scooter / Wheelchair Class C

¹ When driving in reverse mode a sharp interrupted audio signal will sound.

² The distance will be reduced if the scooter is used frequently on slopes, rough ground etc.

³ Minimum width of corridor in which the scooter can be turned to face the opposite direction: 2600 mm.

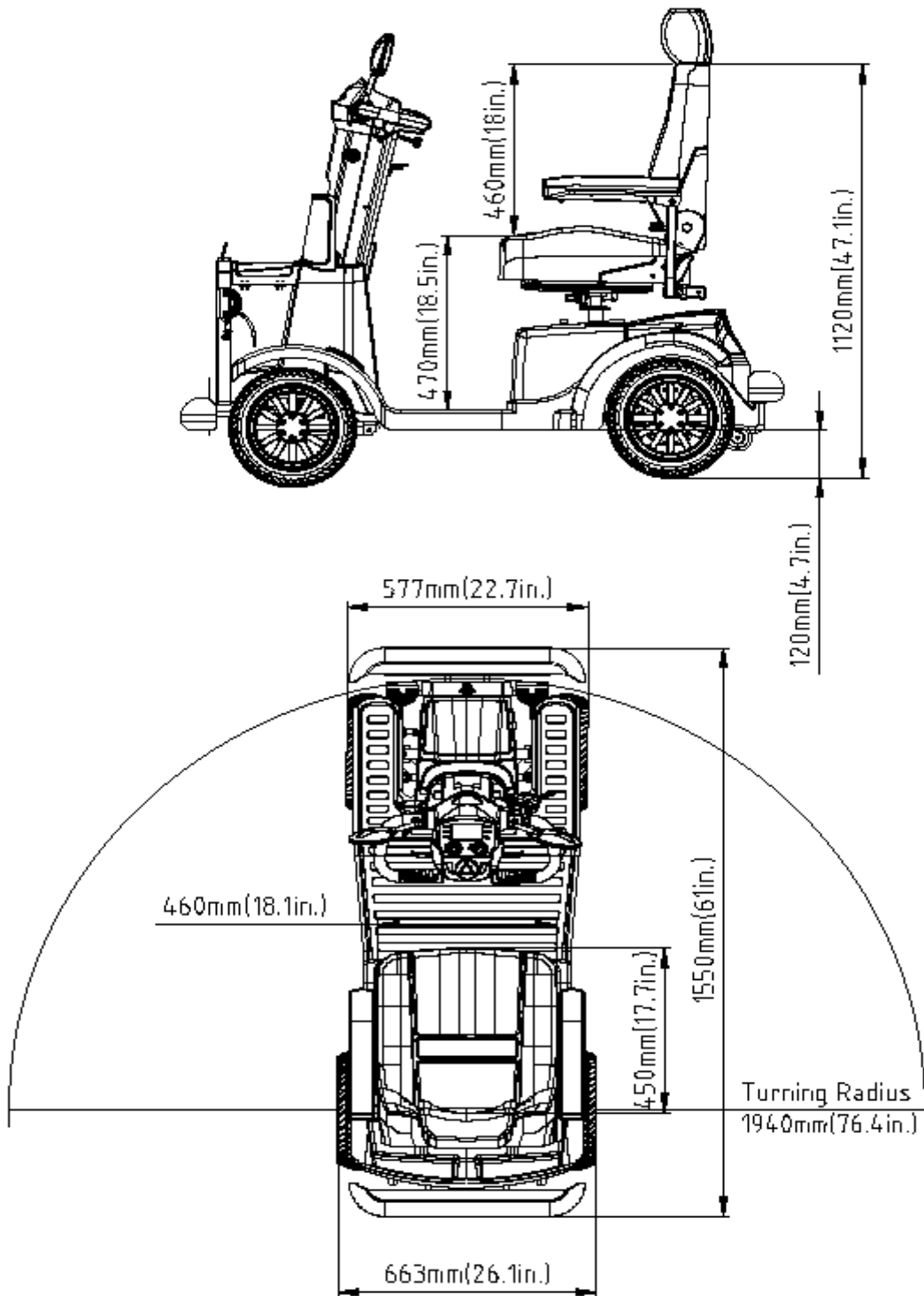

Figure 22: Gatsby Scooter Dimensions

- **Expected Service Life:** 5 years depending on usage. After this period the scooter may need to undergo a major service or be replaced.
- The PVC leather used for the seat assemblies and armrests has been successfully tested according to EN 1021-1:2014 (Ignition source: Smoldering cigarette) and EN1021-2:2014 (Ignition source: Match flame equivalent).

A2. DISASSEMBLY + ASSEMBLY

DISASSEMBLY

You can disassemble the scooter into several pieces: the seat, the main section, the rear shroud, the battery shroud and the batteries.

No tools are required to disassemble or assemble your scooter, but keep in mind that the disassembled sections of the scooter take up more floor space than the assembled unit. Always disassemble or assemble your scooter on a level, dry surface with sufficient room for you to work and move around your scooter– about 2 meters (6.6 feet) in all directions. Remember that some scooter components are heavy and you may need assistance when lifting them.

WARNING! Do not lift beyond your physical capability. Ask for assistance when necessary while disassembling or assembling your scooter.

STEPS TO DISASSEMBLE THE GATSBY SCOOTER:

1. Remove the seat by lifting it straight up and off of the scooter. If you encounter resistance when removing the seat, disengage the seat rotation lever and swivel the seat back and forth while lifting up on the seat (See picture below).
3. Remove the battery shroud.
3. Gently pull the battery shroud up and off of the scooter.
4. Disconnect the battery tie-down strap.
5. Unplug both battery harnesses by pulling each harness out of its mating plug. (See picture below).
6. Remove the batteries from the battery wells.

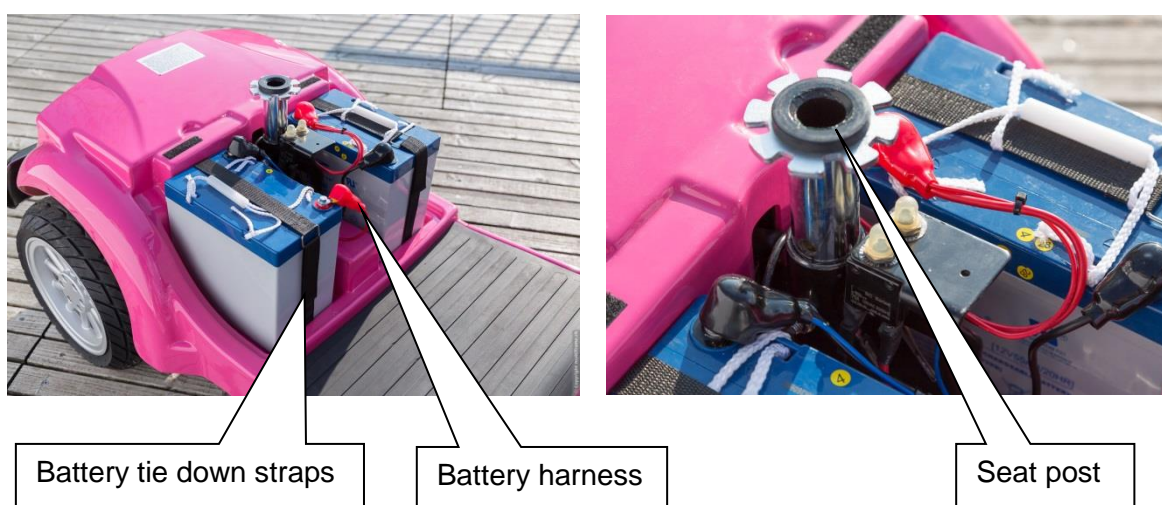

Figure 23: Disassembly of batteries and the seat post

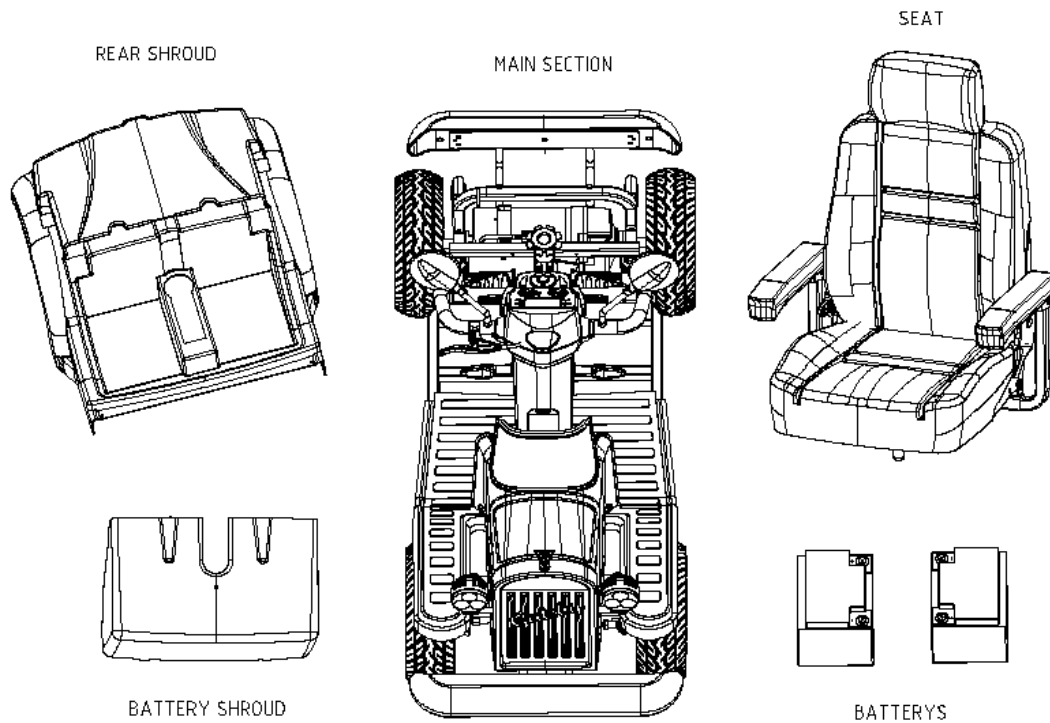

Figure 24: Disassembled Gatsby Scooter

WARNING! Failure to unplug both battery harnesses and the front-to-rear cable prior to separating the front and rear sections could result in permanent damage to the scooter.

ASSEMBLY

7. Reinstall the batteries to the battery wells.
8. Connect both battery harnesses (Figure 25 below).
9. Secure the battery tie-down strap.
10. Reinstall the battery shroud.
11. Reinstall the seat and rotate it into place

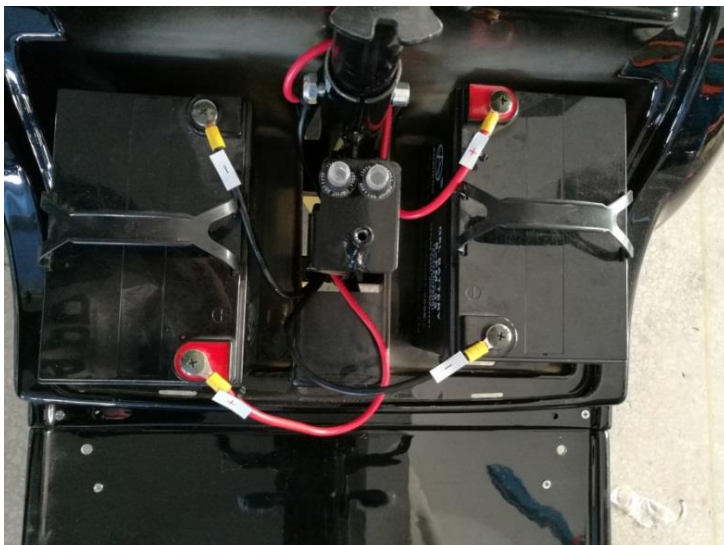

Fig. 25: Connecting the batteries

A3. STORAGE INSTRUCTIONS

- Always store in a dry area protected from freezing to avoid damage to the scooter and premature wear of the batteries.
- Avoid exposure to rain, snow, ice, salt or stagnant water. Keep your scooter clean and dry
- Never expose the electronic components of the scooter to humidity (rain, snow, mist, or water from washing), as it may damage electronic circuits.
- During the storage, check the charge once a month and recharge the batteries as needed. You must complete a full charge cycle every month or damage to batteries can occur
- Avoid extreme temperature of hot and cold during storage. Freezing can damage low charged batteries and they may become unusable



Manufacturer:

Rehabilitations-Systeme AG, Roggenstrasse 3
CH-4665 Oftringen, Switzerland
www.vintage-mobility.ch

Manufactured in China by:

Jinhua Ruidi Vehicle Industry Co. Ltd.
No. 3566, Erhuan South RD
Jinhua Zhejiang, China

MARKING PLATE



Rehabilitations-Systeme AG **Reha**sys
Roggenstrasse 3 CH-4665 Oftringen Switzerland



Hotline: +41 61 487 94 44

Type	Gatsby
Art.No.	0100010
Serial No.	G-0100010-201703001
Production year	2017/04



Please read and follow the
instructions for use.

Max. speed: 15 km/h (9.3 mph)
Ground clearance: 100 mm (3.93 in)
Safe incline angle: 8°
Rated load/axis: 120 kg (264 lbs)
Rated total weight: 290 kg (639 lbs)

Oftringen, 2017-05-03