



An Oshkosh Corporation Company

Service and Maintenance Manual

Models **1932RS/6RS** **3248RS/10RS**

3121273

November 26, 2018 - Rev F

CE

ANSI



An Oshkosh Corporation Company

SECTION A. INTRODUCTION - MAINTENANCE SAFETY PRECAUTIONS

GENERAL

This section contains the general safety precautions which must be observed during maintenance of the aerial platform. It is of utmost importance that maintenance personnel pay strict attention to these warnings and precautions to avoid possible injury to themselves or others, or damage to the equipment. A maintenance program must be followed to ensure that the machine is safe to operate.

⚠ WARNING

MODIFICATION OR ALTERATION OF AN AERIAL WORK PLATFORM SHALL BE MADE ONLY WITH WRITTEN PERMISSION FROM THE MANUFACTURER.

The specific precautions to be observed during maintenance are inserted at the appropriate point in the manual. These precautions are, for the most part, those that apply when servicing hydraulic and larger machine component parts.

Your safety, and that of others, is the first consideration when engaging in the maintenance of equipment. Always be conscious of weight. Never attempt to move heavy parts without the aid of a mechanical device. Do not allow heavy objects to rest in an unstable position. When raising a portion of the equipment, ensure that adequate support is provided.

⚠ WARNING

SINCE THE MACHINE MANUFACTURER HAS NO DIRECT CONTROL OVER THE FIELD INSPECTION AND MAINTENANCE, SAFETY IN THIS AREA RESPONSIBILITY OF THE OWNER/OPERATOR.

HYDRAULIC SYSTEM SAFETY

It should be noted that the machines hydraulic systems operate at extremely high potentially dangerous pressures. Every effort should be made to relieve any system pressure prior to disconnecting or removing any portion of the system.



MAINTENANCE

⚠ WARNING

FAILURE TO COMPLY WITH SAFETY PRECAUTIONS LISTED IN THIS SECTION COULD RESULT IN MACHINE DAMAGE, PERSONNEL INJURY OR DEATH AND IS A SAFETY VIOLATION.

- ENSURE REPLACEMENT PARTS OR COMPONENTS ARE IDENTICAL OR EQUIVALENT TO ORIGINAL PARTS OR COMPONENTS.
- NO SMOKING IS MANDATORY. NEVER REFUEL DURING ELECTRICAL STORMS. ENSURE THAT FUEL CAP IS CLOSED AND SECURE AT ALL OTHER TIMES.
- REMOVE ALL RINGS, WATCHES AND JEWELRY WHEN PERFORMING ANY MAINTENANCE.
- DO NOT WEAR LONG HAIR UNRESTRAINED, OR LOOSE-FITTING CLOTHING AND NECKTIES WHICH ARE APT TO BECOME CAUGHT ON OR ENTANGLED IN EQUIPMENT.
- OBSERVE AND OBEY ALL WARNINGS AND CAUTIONS ON MACHINE AND IN SERVICE MANUAL.
- KEEP OIL, GREASE, WATER, ETC. WIPED FROM STANDING SURFACES AND HAND HOLDS.
- USE CAUTION WHEN CHECKING A HOT, PRESSURIZED COOLANT SYSTEM.
- NEVER WORK UNDER AN ELEVATED SCISSOR UNTIL PLATFORM HAS BEEN SAFELY RESTRAINED FROM ANY MOVEMENT BY BLOCKING OR OVERHEAD SLING, OR SAFETY PROP HAS BEEN ENGAGED.
- BEFORE MAKING ADJUSTMENTS, LUBRICATING OR PERFORMING ANY OTHER MAINTENANCE, SHUT OFF ALL POWER CONTROLS.
- BATTERY SHOULD ALWAYS BE DISCONNECTED DURING REPLACEMENT OF ELECTRICAL COMPONENTS.
- KEEP ALL SUPPORT EQUIPMENT AND ATTACHMENTS STOWED IN THEIR PROPER PLACE.
- USE ONLY APPROVED, NONFLAMMABLE CLEANING SOLVENTS.

REVISION LOG

Original Issue	A - January 30, 2012
Revised	B - August 1, 2012
Revised	C - January 29, 2013
Revised	D - April 8, 2013
Revised	E - June 29, 2018 - Revised Covers
Revised	F - November 26, 2018

TABLE OF CONTENTS

SECTION A - INTRODUCTION - MAINTENANCE SAFETY PRECAUTIONS

A	General	A
	Hydraulic System Safety	A
	Maintenance	A

SECTION 1 - SPECIFICATIONS

1.1	Specifications	1-1
	Platform Capacities	1-1
	Dimensional Data	1-2
	Tires	1-2
	Batteries	1-2
	Battery Quick-Disconnect - (If Equipped)	1-2
	Electrical System	1-3
	Motors	1-3
	Travel Speed	1-3
	Lift Speed	1-3
1.2	Critical Stability Weights	1-4
1.3	Lubrication	1-4
	Hydraulic Oil	1-4
	Pressure Settings	1-4
1.4	Limit Switches	1-5
	Tilt Alarm	1-5
	High Drive Speed Cutout	1-5
1.5	Cylinder Specifications	1-5
1.6	Major Component Weights	1-5
1.7	Torque Requirements	1-5
	Torque Charts	1-6

SECTION 2 - GENERAL

2.1	Machine Preparation, Inspection, and Maintenance	2-1
	General	2-1
	Preparation, Inspection, and Maintenance	2-1
	Pre-Start Inspection	2-1
	Pre-Delivery Inspection and Frequent Inspection	2-1
	Annual Machine Inspection	2-1
	Preventative Maintenance	2-1
2.2	Preventive Maintenance and Inspection Schedule	2-2
	Maintenance and Inspection Schedule Codes:	2-2
	Footnotes:	2-2
2.3	Service and Guidelines	2-5
	General	2-5
	Safety and Workmanship	2-5
	Cleanliness	2-5
	Components Removal and Installation	2-5
	Component Disassembly and Reassembly	2-5
	Pressure-Fit Parts	2-5
	Bearings	2-5
	Gaskets	2-5
	Bolt Usage and Torque Application	2-5
	Hydraulic Lines and Electrical Wiring	2-6
	Hydraulic System	2-6
	Lubrication	2-6
	Battery	2-6

TABLE OF CONTENTS

2.4	Lubrication and Information	2-6
	Hydraulic System	2-6
	Hydraulic Oil	2-6
	Changing Hydraulic Oil	2-7
	Lubrication Specifications	2-7
2.5	Cylinder Drift Test	2-7
	Platform Drift.....	2-7
	Cylinder Drift	2-7
2.6	Pins and Composite Bearing Repair Guidelines	2-8

SECTION 3 - CHASSIS & SCISSOR ARMS

3.1	Machine Component Covers.....	3-1
3.2	Battery Removal/Maintenance	3-2
	Battery Quick-Disconnect - (If Equipped)	3-2
	Battery Maintenance and Safety Practices	3-2
3.3	Battery Charger	3-3
3.4	Battery Charging	3-4
	Battery Charger Fault (LED Flash).....	3-5
	Battery Charger Maintenance	3-5
	Battery Charger Troubleshooting	3-5
3.5	DC to AC Inverter (if equipped)	3-7
	Inverter Location on Machine	3-7
	Inverter Operation.....	3-8
	Inverter Troubleshooting	3-8
	Inverter Specifications	3-8
3.6	Ground Control Station	3-9
	Components Location	3-9
	Removal (All Models)	3-9
	Installation	3-9
3.7	Main Power Contactor Relay	3-10
3.8	Elevation Limit Switch Assembly	3-10
	Location	3-10
	Installation	3-10
	Switch Adjustment	3-11
3.9	LSS - Scissor Arm Angle Sensor - Location	3-12
3.10	Tilt Sensor Replacement	3-12
	Tilt Sensor Removal.....	3-13
	Tilt Sensor Installation	3-13
	Tilt Sensor Switch - Adjustment Procedure	3-13
3.11	Traction System	3-14
	Theory of Operation	3-14
	Common Traction System Difficulties	3-15
3.12	Power Control Module - ZAPI	3-16
	ZAPI Power Module Electrical Evaluation	3-18
3.13	Drive Motor Servicing	3-19
	Drive Motor Troubleshooting	3-19
	Drive Motor Electrical Evaluation.....	3-19
	Servicing Guidelines	3-19
	Brake - Manual Disengage Procedure	3-20
	Drive Motor Removal	3-21
	Drive Motor Disassembly	3-22
	Drive Motor Inspection and Service	3-23
	Drive Motor Reassembly.....	3-23
	Drive Motor Installation.....	3-25

3.14	Torque Hub Servicing	3-26
	Roll Test	3-26
	Leak Test	3-26
	Oil Check/Fill Procedure	3-26
	Main Gearbox Disassembly	3-27
	Input Carrier Disassembly	3-28
	Hub Disassembly	3-29
	Spindle Disassembly	3-30
	Tightening and Torquing Bolts	3-31
	Assembly Tools	3-31
	Spindle Assembly	3-32
	Hub Assembly	3-33
	Input Carrier Assembly	3-34
	Main Gearbox Assembly	3-35
3.15	Steer Assembly Components	3-37
3.16	Arms and Platform Positioning and Support	3-39
3.17	Platform Removal	3-39
3.18	Scissor Arms Removal	3-39
	Removing Scissor Arm Assembly as a Complete Unit	3-39
	Removing/Installing Scissor Arms Individually	3-39
3.19	Platform Control Station	3-56
	Installation/Removal	3-56
	Control Station Harness Installation to Scissor Arms	3-56
	Control Station Disassembly	3-56
	Overview of Control Station Components	3-57
	Joystick Controller	3-58

SECTION 4 - HYDRAULICS

4.1	Cylinders - Theory of Operation	4-1
4.2	Valves - Theory of Operation	4-1
	Solenoid Control Valves (Bang-Bang)	4-1
	Relief Valves	4-1
	Crossover Relief Valves	4-1
	Proportional Valve	4-1
	Manual Descent Valve	4-1
4.3	Pump/Motor	4-2
	Pump Motor Electrical Evaluation	4-2
	Hydraulic Oil Check Procedure	4-3
	Pump/Tank Disassembly	4-4
	Pump Motor Removal	4-4
4.4	Lift Pressure Setting Procedure	4-6
4.5	Cylinder Checking Procedure	4-6
4.6	Lift Cylinder Removal	4-7
4.7	Cylinder Repair	4-8
	Disassembly	4-8
	Steer Cylinder Piston Removal	4-9
	Cleaning and Inspection	4-9
	Assembly	4-10
	Lift Cylinder - LSS Pressure Sensor Location (If equipped)	4-12

SECTION 5 - JLG CONTROL SYSTEM

5.1	Hand Held Analyzer	5-1
	Diagnostic Port	5-1
	To Connect the Hand Held Analyzer	5-1
	Using the Analyzer:	5-2
	Changing the Access Level of the Hand Held Analyzer	5-3
	Adjusting Parameters Using the Hand Held Analyzer	5-4
	Machine Setup	5-4
	Joystick Calibration	5-5
	Updating Software	5-5
5.2	Machine Model Adjustment	5-13
5.3	Machine Configuration Programming Information	5-14

SECTION 6 - DIAGNOSTIC TROUBLE CODES

6.1	Introduction	6-1
	System Fault/DTC Indication	6-1
6.2	Diagnostic Trouble Codes (DTC)	6-1
6.3	X-Connector References	6-1
6.4	DTC Index	6-2
6.5	DTC Check Tables	6-5

SECTION 7 - GENERAL ELECTRICAL INFORMATION & SCHEMATICS

7.1	General	7-1
7.2	Multimeter Basics	7-1
	Grounding	7-1
	Backprobing	7-1
	Min/Max	7-1
	Polarity	7-1
	Scale	7-1
	Continuity Measurement Over Long Distances	7-4
	Requirements:	7-4
	Procedure	7-4
7.3	Applying Silicone Dielectric Compound to Amp Connectors	7-5
	Assembly	7-6
	Disassembly	7-7
	Wedge Lock	7-8
	Service - Voltage Reading	7-9
7.4	Working With Deutsch Connectors	7-10
	DT/DTP Series Assembly	7-10
	DT/DTP Series Disassembly	7-10
	HD30/HDP20 Series Assembly	7-10
	HD30/HDP20 Series Disassembly	7-11
7.5	Switches	7-12
	Basic check	7-12
	Limit Switches	7-12
	Automatic Switches	7-13
	Switch Wiring - Low Side, High Side	7-13
7.6	Circuit Boards: Inputs and Outputs	7-14
7.7	Electrical Schematics and Layouts	7-17
7.8	Hydraulic Schematic	7-26

LIST OF FIGURES

FIGURE NO.	TITLE	PAGE NO.
1-1.	Torque Chart (SAE Fasteners - Sheet 1 of 5)	1-6
1-2.	Torque Chart (SAE Fasteners - Sheet 2 of 5)	1-7
1-3.	Torque Chart (SAE Fasteners - Sheet 3 of 5)	1-8
1-4.	Torque Chart (Metric Fasteners - Sheet 4 of 5)	1-9
1-5.	Torque Chart (Metric Fasteners - Sheet 5 of 5)	1-10
3-1.	Machine Frame Covers (All Models)	3-1
3-2.	Battery Location and Hold Down Bar (All Models)	3-2
3-3.	Battery Fluid Level	3-3
3-4.	Battery Charger (Delta Q)	3-3
3-5.	Battery Charger (Green Power)	3-4
3-6.	Charger Decal LED Indicators	3-4
3-7.	DC to AC Inverter Components	3-7
3-8.	Inverter On/Off Switch Location	3-7
3-9.	Ground Control Station Component Location (All Models)	3-9
3-10.	Ground Control Station Removal	3-9
3-11.	Main Power Contactor Relay Location (All Models)	3-10
3-12.	Elevation Limit Switch Location	3-10
3-13.	Elevation Limit Switch Mounting	3-10
3-14.	1932RS/6RS - Elevation Limit Switch Adjustment	3-11
3-15.	3248RS/10RS - Elevation Limit Switch Adjustment	3-11
3-16.	LSS - Scissor Arm Angle Sensor - Location Rear of Machine	3-12
3-17.	Tilt Sensor Installation	3-12
3-18.	Tilt Sensor Switch - Bubble Level	3-13
3-19.	Tilt Sensor Switch - Adjustment	3-13
3-20.	Traction Control Circuit - ZAPI Power Module	3-14
3-21.	ZAPI Power Module Location and Orientation (All models)	3-16
3-22.	Main Electrical Power Connections - (1001129845 - ZAPI Power Module)	3-17
3-23.	Brakes - Manual Disengage Procedure	3-20
3-24.	Electric Drive Motor Removal	3-21
3-25.	Drive Motor Components	3-22
3-26.	Drive Motor Shaft Bearing	3-24
3-27.	Wire Harness Connections	3-24
3-28.	Drive Motor Assembly	3-25
3-29.	Main Gearbox Disassembly	3-27
3-30.	Input Carrier Disassembly	3-28
3-31.	Hub Disassembly	3-29
3-32.	Spindle Disassembly	3-30
3-33.	Assembly Tool 1	3-31
3-34.	Assembly Tool 2	3-31
3-35.	Assembly Tool 3	3-31
3-36.	Spindle Assembly	3-32
3-37.	Hub Assembly	3-33
3-38.	Input Carrier Assembly	3-34
3-39.	Main Gearbox Assembly	3-35
3-40.	1932RS/6RS - Steer Assembly	3-37
3-41.	3248RS/10RS - Steer Assembly	3-38
3-42.	Arms and Platform Positioning and Support	3-40
3-43.	1932RS/6RS - Scissor Arm Assembly	3-41
3-44.	1932RS/6RS - Scissor Arm Assembly - Pin Configuration	3-42
3-45.	3248RS/10RS - Scissor Arm Assembly	3-43
3-46.	3248RS/10RS - Scissor Arm Assembly - Pin Configuration	3-44
3-47.	Platform cable (3248RS/10RS) - Sheet 1 of 4	3-45
3-48.	Platform cable (3248RS/10RS) - Sheet 2 of 4	3-46
3-49.	Platform cable (3248RS/10RS) - Sheet 3 of 4	3-47

TABLE OF CONTENTS

3-50.	Platform cable (3248RS/10RS) - Sheet 4 of 4	3-48
3-51.	Platform cable (LSS - 3248RS/10RS) - Sheet 1 of 3	3-49
3-52.	Platform cable (LSS - 3248RS/10RS) - Sheet 2 of 3	3-50
3-53.	Platform cable (LSS - 3248RS/10RS) - Sheet 3 of 3	3-51
3-54.	Platform cable (FTSW - 3248RS/10RS) - Sheet 1 of 4	3-52
3-55.	Platform cable (FTSW - 3248RS/10RS) - Sheet 2 of 4	3-53
3-56.	Platform cable (FTSW - 3248RS/10RS) - Sheet 3 of 4	3-54
3-57.	Platform cable (FTSW - 3248RS/10RS) - Sheet 4 of 4	3-55
3-58.	Platform Control Station Installation	3-56
3-59.	Platform Control Station Disassembly	3-56
3-60.	Platform Control Station Components - External	3-57
3-61.	Platform Control Station Components - Internal	3-57
3-62.	Joystick	3-58
4-1.	Hydraulic Oil Check Procedure - All Machines	4-4
4-2.	Hydraulic Motor, Pump and Tank Assembly (All Machines)	4-5
4-3.	Cylinder Barrel Support	4-8
4-4.	Cylinder Rod Support	4-8
4-5.	Gar-Max Bearing Installation	4-9
4-6.	Rod Seal Installation	4-10
4-7.	Poly-Pak Piston Seal Installation	4-10
4-8.	Wiper Seal Installation	4-10
4-9.	Installation of Head Seal Kit	4-10
4-10.	Rod Assembly Installation	4-11
4-11.	LSS Pressure Sensors Location - 1932RS/6RS - (If Equipped)	4-12
4-12.	LSS Pressure Sensors Location - 3248RS/10RS - (If Equipped)	4-12
4-13.	1932RS/6RS - Lift Cylinder	4-13
4-14.	3248RS/10RS - Lift Cylinder	4-14
4-15.	1932RS/6RS - Steer Cylinder	4-15
4-16.	3248RS/10RS - Steer Cylinder	4-16
5-1.	Hand Held Analyzer	5-1
5-2.	Diagnostic Port Location	5-1
5-3.	Analyzer Flow Chart (Software Version P1.7) Sheet 1 of 7	5-6
5-4.	Analyzer Flow Chart (Software Version P1.7) Sheet 2 of 7	5-7
5-5.	Analyzer Flow Chart (Software Version P1.7) Sheet 3 of 7	5-8
5-6.	Analyzer Flow Chart (Software Version P1.7) Sheet 4 of 7	5-9
5-7.	Analyzer Flow Chart (Software Version P1.7) Sheet 5 of 7	5-10
5-8.	Analyzer Flow Chart (Software Version P1.7) Sheet 6 of 7	5-11
5-9.	Analyzer Flow Chart (Software Version P1.7) Sheet 7 of 7	5-12
7-1.	Voltage Measurement (DC)	7-2
7-2.	Resistance Measurement	7-2
7-3.	Continuity Measurement	7-3
7-4.	Current Measurement (DC)	7-3
7-5.	AMP Connector	7-5
7-6.	Connector Assembly (1 of 4)	7-6
7-7.	Connector Assembly (2 of 4)	7-6
7-8.	Connector Assembly (3 of 4)	7-7
7-9.	Connector Assembly (4 of 4)	7-7
7-10.	Connector Disassembly	7-8
7-11.	Connector Installation	7-9
7-12.	DT/DTP Contact Installation	7-10
7-13.	DT/DTP Contact Removal	7-10
7-14.	HD/HDP Contact Installation	7-10
7-15.	HD/HDP Locking Contacts Into Position	7-11
7-16.	HD/HDP Contact Removal	7-11
7-17.	HD/HDP Unlocking Contacts	7-11
7-18.	Electrical Schematic - (Global) - Sheet 1 of 7	7-17
7-19.	Electrical Schematic - (Global) - Sheet 2 of 7	7-18
7-20.	Electrical Schematic - (Global) - Sheet 3 of 7	7-19

7-21.	Electrical Schematic - (Global) - Sheet 4 of 7	7-20
7-22.	Electrical Schematic - (Global) - Sheet 5 of 7	7-21
7-23.	Electrical Schematic - (Global) - Sheet 6 of 7	7-22
7-24.	Electrical Schematic - (Global) - Sheet 7 of 7	7-23
7-25.	Electrical Components Layout - Sheet 1 of 2.....	7-24
7-26.	Electrical Components Layout - Sheet 2 of 2.....	7-25
7-27.	Hydraulic Schematic	7-26

LIST OF TABLES

TABLE NO.	TITLE	PAGE NO.
1-1	Operating Specifications.....	1-1
1-2	Platform Capacities.....	1-1
1-3	Machine Dimensions.....	1-2
1-4	Tire Specifications.....	1-2
1-5	Battery Specifications.....	1-2
1-6	Electrical System Specifications.....	1-3
1-7	Travel Speed.....	1-3
1-8	Lift Speed.....	1-3
1-9	Critical Stability Weights.....	1-4
1-10	Hydraulic Oil.....	1-4
1-11	Lubrication Specifications.....	1-4
1-12	Hydraulic Oil Specifications.....	1-4
1-13	Pressure Settings.....	1-4
1-14	Tilt Activation Setting.....	1-5
1-15	High Drive Cutout Height.....	1-5
1-16	Cylinder Specifications.....	1-5
1-17	Major Component Weights.....	1-5
1-18	Torque Requirements.....	1-5
2-1	Inspection and Maintenance Responsibilities.....	2-2
2-2	Preventive Maintenance & Inspection Schedule.....	2-3
2-3	Cylinder Drift.....	2-7
3-1	Battery Charger Specs (Delta Q).....	3-3
3-2	Battery Charger (Green Power).....	3-4
3-3	ZAPI Power Module Specifications.....	3-16
3-4	Module Terminal Functions.....	3-16
3-5	Joystick Specifications.....	3-58
3-6	Connector Chart.....	3-58
4-1	Hydraulic System Capacities.....	4-3
4-2	Lift Pressure Settings.....	4-6
4-3	Pressure Fitting Adapter.....	4-6
5-1	Machine Model Adjustment.....	5-13
5-2	Machine Configuration Programming Information (Software Version P1.7).....	5-14
7-1	Power Module - J1 Connector Pin Function.....	7-14
7-2	Power Module - J2 Connector Pin Function.....	7-15

SECTION 1. SPECIFICATIONS

1.1 SPECIFICATIONS

Table 1-1. Operating Specifications

DESCRIPTION	1932RS/6RS	3248RS/10RS
PLATFORM		
Maximum Platform Height	19 ft. (5.8 m)	32 ft. (9.75 m)
DRIVING		
Maximum Drive Speed	Stowed: Elevated:	2.5 mph (4 kph) 0.3 mph (0.5 kph)
Maximum Stowed Travel Grade (Gradeability)	25% (14°)	
Inside Turning Radius	23.6 in. (60 cm)	47.9 in. (121.7 cm)
Outside Turning Radius	87.9 in. (221.9 cm)	125.3 in. (318.1 cm)
CHASSIS		
Approximate Gross Machine Weight ANSI/CSA: CE:	3,000 lb. (1,360 kg) 3,450 lb. (1,565 kg)	5,070 lb. (2,300 kg) 6,050 lb. (2,744 kg)
Maximum Tire Load (per wheel) ANSI/CSA: CE:	1,365 lb. (620 kg)	1,835 lb. (832 kg) 2,070 lb. (940 kg)
Ground Bearing Pressure ANSI/CSA: CE:	130 PSI (9.18 kg/cm ²)	81 PSI (5.69 kg/cm ²) 108 PSI (7.6 kg/cm ²)
Ground Clearance	3.1 in. (7.8 cm)	4.1 in. (10.3 cm)

Platform Capacities

Table 1-2. Platform Capacities

SPECIFICATION	MACHINE MODEL	MAXIMUM PLATFORM CAPACITY ⁽¹⁾	MAXIMUM CAPACITY ALLOWED ON PLATFORM EXTENSION	MAXIMUM PERSONS ALLOWED IN PLATFORM	MAX. SIDE FORCE (Platform Fully Extended @ Max. Capacity)	MAXIMUM OPERATING WIND SPEED
ANSI/CSA/JPN	1932	500 Lb. (227 Kg)	250 Lb. (113 Kg)	2	100 Lb. (445 N)	28 mph
	3248	705 Lb. (320 Kg)	250 Lb. (113 Kg)	2	100 Lb. (445 N)	28 mph
ANSI EXPORT	1932	480 Lb. (218 Kg)	240 Lb. (109 Kg)	2	100 Lb. (445 N)	28 mph
	3248	683 Lb. (310 Kg)	236 Lb. (107 Kg)	2	100 Lb. (445 N)	28 mph
CE	6RS	230 Kg	120 Kg	Indoor - 2 Persons + 70 Kg	400 N	0 m/s
				Outdoor - 1 Person + 150 Kg	200 N	12.5 m/s
	10RS	320 Kg	120 Kg	Indoor - 2 Persons + 160 Kg	400 N	0 m/s
				Outdoor - 1 Person + 240 Kg	200 N	12.5 m/s

NOTE: (1) Maximum Platform Capacity includes platform and platform extension.

Dimensional Data

Table 1-3. Machine Dimensions

DESCRIPTION	1932RS/6RS	3248RS/10RS
Platform Height - Elevated	19 ft. (5.8 m)	32 ft. (9.75 m)
Platform Height - Stowed	79.4 in. (2.02 m)	95.8 in. (2.43 m)
Platform Height - Stowed (Rails Down)	N/A	78.3 in. (1.99 m)
Working Height	25 ft. (7.62 m)	38 ft. (11.5 m)
Rail Height (From platform floor)	40 in. (101.6 cm)	40.5 in. (102.9 cm)
Rail Height (Platform Floor to Top of Rail)	40 in. (101.6 cm)	41 in. (104.3 cm) - ANSI 43.6 in. (110.7 cm) - CE
Rail Height - Folded (Ground to Mid Rail)	69.3 in. (176 cm) CE ONLY	78.3 in. (198.9 cm) - ANSI 77.6 in. (197.1 cm) - CE
Overall Machine Width	32 in. (81.28 cm)	48 in. (122 cm)
Overall Machine Length (w/ladder)	81.5 in. (207 cm)	90 in. (2.28 m) - ANSI 94.8 in. (240.7 cm) - CE
Platform Size - Length	71.7 in. (182 cm)	84.7 in. (215.1 cm)
Platform Size - Width	26.9 in. (68.4 cm)	42.5 in. (107.9 cm)
Wheelbase	55 in. (139.7 cm)	73 in. (185.4 cm)

Tires

Table 1-4. Tire Specifications

DESCRIPTION	1932RS/6RS	3248RS/10RS
Size	12.71 in. x 3.94 in. (323 mm x 100 mm)	16 in. x 5 in. (406 mm x 127 mm)
Wheel Bolt Torque	120 ft.lb. (163 Nm)	

Batteries

Table 1-5. Battery Specifications

DESCRIPTION	ALL MACHINES
Voltage (24V-DC System - Series)	6 V per battery
Amp Hour (Standard Battery)	220 Amp Hour @ 20 HR. Rate
Reserve Capacity (Standard Battery)	447 Minutes

NOTICE

JLG MACHINES EQUIPPED WITH DELTA Q BATTERY CHARGERS ARE DESIGNED FOR THE BEST PERFORMANCE WITH OEM FACTORY APPROVED BATTERIES.

APPROVED JLG REPLACEMENT BATTERIES ARE AVAILABLE THROUGH JLG'S AFTERMARKET PARTS DISTRIBUTION CENTERS OR JLG'S AFTERMARKET PROGRAMS. FOR ASSISTANCE WITH PROPER BATTERY REPLACEMENT, PLEASE CONTACT YOUR LOCAL JLG SUPPORT OFFICE.

BATTERIES APPROVED BY JLG HAVE BEEN TESTED FOR COMPATIBILITY WITH THE ALGORITHM PROGRAMMING OF THE DELTA Q BATTERY CHARGER TO OPTIMIZE BATTERY LIFE AND MACHINE CYCLE TIMES. THE USE OF NON APPROVED BATTERIES IN YOUR JLG EQUIPMENT MAY RESULT IN PERFORMANCE ISSUES OR BATTERY CHARGER FAULT CODES. JLG ASSUMES NO RESPONSIBILITY FOR SERVICE OR PERFORMANCE ISSUES ARISING FROM THE USE OF NON APPROVED BATTERIES.

Battery Quick-Disconnect - (If Equipped)

Machines equipped with the battery quick-disconnect allow all machine power to be easily disconnected at the batteries without removing battery

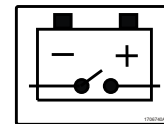

cables from the battery posts. To disconnect power, locate the RED quick-disconnect connector on top of the batteries inside the battery compartment and pull halves apart.

Electrical System

Table 1-6. Electrical System Specifications

DESCRIPTION	ALL MACHINES
Electrical System Voltage (DC)	24V - DC
Battery Charger: (1001129847)	
Input:	
AC Input Voltage:	85-265V AC
Nominal AC Input Voltage:	120VAC / 230VAC RMS
Input Frequency:	45 - 65Hz
Max. AC Input Current:	12A - RMS @ 108V AC
Ingress Protection:	IP46 NEMA4 Type 4
Operating Temperature:	-22°F (-30°C) to 122°F (+50°C)
Output:	
Nominal DC Output Voltage:	24V
Max. DC Output Voltage:	33.6V
Max DC Output Current:	25A
Max. Interlock Current:	1A
Protection:	
Output Reverse Polarity:	Electronic Protection-Auto Reset
Output Short Circuit:	Electronic Protection-Auto Reset
AC Overload:	Current Limited
DC Overload:	Current Limited
DC to AC Inverter - Output Rating: (OPTION)	120V-AC, 60Hz - 7.5 Amps - 900 Watts - Modified Sinewave

Motors

• **Drive Motor**

Type: Shunt Wound, Sepex 24V DC

Power: 0.65 Horsepower @ 3750 rpm

• **Hydraulic Pump/Electric Motor Assembly
(All Models)**

Type: Series Wound Permanent Magnet 24V DC

Power: 3kW

Travel Speed

Table 1-7. Travel Speed

MODEL	ELEVATED SPEED			MAXIMUM SPEED (PLATFORM LOWERED)		
	UNIT OF MEASURE					
	Mph	Sec/25 ft (Sec/7.6 m)	Kph	Mph	Sec/25 ft (Sec/7.6 m)	Kph
1932RS/6RS	0.3	59 - 65	0.5	2.5	6.85 - 8.5	4
3246RS/10RS	0.3	57 - 65	0.5	2.5	6.85 - 8.5	4

Lift Speed

NOTE: Maximum rated load in platform on measured lift speeds. Platform fully raised and lowered.

Table 1-8. Lift Speed

MODEL	LIFT UP (SECONDS)	LIFT DOWN (SECONDS)
1932RS/6RS	22 - 29	21 - 31
3246RS/10RS	55 - 65	40 - 50

1.2 CRITICAL STABILITY WEIGHTS



WARNING

DO NOT REPLACE ITEMS CRITICAL TO STABILITY, SUCH AS BATTERIES OR SOLID TIRES, WITH ITEMS OF DIFFERENT WEIGHT OR SPECIFICATION. DO NOT MODIFY UNIT IN ANY WAY TO AFFECT STABILITY.

Table 1-9. Critical Stability Weights

COMPONENT	1932RS/6RS	3248RS/10RS
Wheel and Tire Assembly - (each)		
Front:	21.6 lb. (9.8 kg)	43 lb. (19.5 kg)
Rear:	21.6 lb. (9.8 kg)	40.5 lb. (18.4 kg)
Wheel/Tire and Drive Assembly (each)	113 lb. (51.3 kg)	134 lb. (60.8 kg)
Batteries (each) Standard:	62 lb. (28.1 kg)	
AGM:	65 lb. (29.5 kg)	
Batteries (combined) Standard:	248 lb. (111.1 kg)	
AGM:	260 lb. (118 kg)	

1.3 LUBRICATION

Hydraulic Oil

NOTE: Hydraulic oils must have anti-wear qualities at least to API Service Classification GL-3, and sufficient chemical stability for mobile hydraulic system service. JLG Industries recommends DTE 10 or Excel 15 hydraulic oil.

Aside from JLG recommendations, it is not advisable to mix oils of different brands or types, as they may not contain the same required additives or be of comparable viscosities.

Table 1-10. Hydraulic Oil

HYDRAULIC SYSTEM OPERATING TEMPERATURE RANGE	SAE VISCOSITY GRADE
0°F to +23°F (-18°C to -5°C)	10W
0°F to 210°F (-18°C to +99°C)	10W-20, 10W-30
50°F to 210°F (+10°C to +210°C)	20W-20

Table 1-11. Lubrication Specifications

KEY	SPECIFICATIONS
MPG	Multipurpose Grease having a minimum dripping point of 350°F. Excellent water resistance and adhesive qualities, and being of extreme pressure type. (Timken OK 40 pounds minimum.)

Table 1-11. Lubrication Specifications

KEY	SPECIFICATIONS
EPGL	Extreme Pressure Gear Lube (oil) meeting API service classification GL-5 or MIL-Spec MIL-L-2105.
HO	JLG Recommends - Mobil DTE 10, EXCEL 15 or ATF - Automatic Transmission Fluid Mobil EAL ENVIRONSYN H 32 (IN U.S.A.) Mobil EAL HYDRAULIC OIL 32 (IN EUROPE)

Table 1-12. Hydraulic Oil Specifications

SPECIFICATION	MOBIL DTE 10 EXCEL 15	MOBIL EAL ENVIRONSYN H 32	MOBIL EAL HYDRAULIC OIL 32
ISO Viscosity Grade	#15	#32	#32
Spec Gravity API	31.9	0.950	—
Pour Point, Max	-40°F (-40°C)	-59°F (-51°C)	-38.2°F (-39°C)
Flash Point, Min.	330°F (166°C)	514.4 °F (268°C)	478°F (248°C)
VISCOSITY SPECIFICATIONS			
at 40°C	15 cSt	33.1 cSt	32 cSt
at 100°C	4.1 cSt	6.36 cSt	7 cSt
at 100°F	80 SUS	—	—
at 210°F	43 SUS	—	—
cp at -30°F	3.2	—	—
Viscosity Index	140	147	189
Operating Temp	—	-20°F (29°C) - 200°F (392°C)	

1001102685_3

Pressure Settings

Table 1-13. Pressure Settings

MODEL	MAIN RELIEF	LIFT RELIEF	STEER RELIEF
1932RS/6RS	2300 psi (158 bar)	2300 psi (158 bar)	1000 psi (69 bar)
3246RS/10RS	2500 psi (172 bar)	2500 psi (172 bar)	1000 psi (69 bar)

1.4 LIMIT SWITCHES

Tilt Alarm

Illuminates a light on the platform control, sounds an alarm and cuts out lift up and drive when the machine is out of level and above stowed depending on model and specifications.

Table 1-14. Tilt Activation Setting

MODEL	TILT SETTING (FRONT TO BACK)	TILT SETTING (SIDE TO SIDE)	PLATFORM ELEVATION @ TILT ACTIVATION (± 6 IN.)
1932RS/6RS - ALL	3°	1.5°	69 in. (1.75 m)
3248RS/10RS - ANSI/CSA/JPN	3°	2°	88.5 in. (2.25 m)
3248RS/10RS - CE	3°	1.5°	88.5 in. (2.25 m)

High Drive Speed Cutout

High drive speed is cut out @ when the platform is raised above the preset height per model as follows:

NOTE: These figures are given with a tolerance of ± 6 in. (0.15 m).

Table 1-15. High Drive Cutout Height

MODEL	HIGH DRIVE SPEED CUTOUT HEIGHT	DRIVE SPEED REDUCTION
1932RS/6RS	68.9 in. (1.75m)	2.5 mph (4kph) to 0.3 mph (0.5 kph)
3248RS/10RS	88.5 in. (2.25 m)	

1.5 CYLINDER SPECIFICATIONS

Table 1-16. Cylinder Specifications

DESCRIPTION	1932RS/6RS	3246RS/10RS
Lift Cylinder Bore	2.48 in. (63 mm)	3.93 in. (100mm)
Lift Cylinder Stroke	43.3 in. (1100 mm)	48.5 in. (1232 mm)
Lift Cylinder Rod Diameter	1.77 in. (45 mm)	2.48 in. (63 mm)
Steer Cylinder Bore	1.5 in. (38.1 mm)	1.57 in. (40 mm)
Steer Cylinder Stroke	4.92 in (125 mm)	6.77 in. (172 mm)
Steer Cylinder Rod Diameter	0.75m in. (19.05 mm)	0.78 in. (20 mm)

1.6 MAJOR COMPONENT WEIGHTS

Table 1-17. Major Component Weights

COMPONENT	1932RS/6RS	3246RS/10RS
Platform	240 lb. (109 kg)	412 lb. (187 kg)
Manual Platform Extension	115 lb. (52 kg)	150 lb. 68 kg
Arm Assembly - (Includes Lift Cylinder)	520 lb. (236 kg)	1,806 lb. (820 kg)
Chassis w/Wheel/Tire and Drive Assembly	2,125 lb. (964 kg)	2,702 lbs (1226 kg)

1.7 TORQUE REQUIREMENTS

Self locking fasteners, such as nylon insert and thread deforming locknuts, are not intended to be reinstalled after removal. Always use new replacement hardware when installing locking fasteners.

Table 1-18. Torque Requirements

DESCRIPTION	TORQUE VALUE (DRY)	INTERVAL HOURS
Front Wheel Spindle Nut	30-40 ft lb (40-54 Nm)	50
Wheel Bolts	105-120 ft lb (142-163 Nm)	50

NOTE: Anytime a wheel bolt is replaced, be sure one of the same length is used. Use bolt shown below on wheels that use the 1/4" (6.4mm) ring.

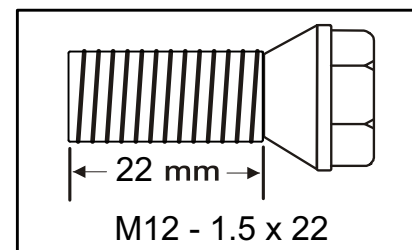

NOTE: After tightening the spindle nut to the proper torque, loosen completely until you can turn by hand. Finger tighten nut by hand without rotating hub. Install cotter pin by backing nut off, if necessary, in order to line up slot.

When maintenance becomes necessary or a fastener has loosened, refer to the Torque Charts on page 1-6 to determine proper torque value.

Torque Charts

Values for Zinc Yellow Chromate Fasteners (Ref 4150707)																			
SAE GRADE 5 BOLTS & GRADE 2 NUTS																			
Size	TPI	Bolt Dia	Tensile Stress Area	Clamp Load	Torque (Dry)		Torque Lubricated		Torque (Loctite® 242™ or 271™ OR Vibra-TITE™ 111 or 140)		Torque (Loctite® 262™ or Vibra-TITE™ 131)		Torque (Loctite® 263 K=0.20)		Torque (Loctite® 242™ or 271™ OR Vibra-TITE™ 111 or 140)		Torque (Loctite® 262™ or Vibra-TITE™ 131) K=0.15		
					IN-LLB	LB	IN-LLB	LB	IN-LLB	LB	IN-LLB	LB	IN-LLB	LB	IN-LLB	LB	IN-LLB	LB	IN-LLB
4	40	0.1120	0.00604	380	8	0.9	6	0.7											
	48	0.1120	0.00661	420	9	1.0	7	0.8											
6	32	0.1380	0.00909	580	16	1.8	12	1.4											
	40	0.1380	0.01015	610	18	2.0	13	1.5											
8	32	0.1640	0.01400	900	30	3.4	22	2.5											
	36	0.1640	0.01474	940	31	3.5	23	2.6											
10	24	0.1900	0.01750	1120	43	4.8	32	3.5											
	32	0.1900	0.02000	1285	49	5.5	36	4											
1/4	20	0.2500	0.0318	2020	96	10.8	75	9	105	12									
	28	0.2500	0.0364	2320	120	13.5	86	10	135	15									
5/16	18	0.3125	0.0524	3340	17	23	13	18	19	26	16	22	25	35	20	25	20	25	25
	24	0.3125	0.0580	3700	19	26	14	19	21	29	17	23	25	35	25	35	20	25	25
3/8	16	0.3750	0.0775	4940	30	41	23	31	35	48	28	38	45	60	40	55	35	50	50
	24	0.3750	0.0878	5600	35	47	25	34	40	54	32	43	7900	50	70	45	60	35	50
7/16	14	0.4375	0.1063	6800	50	68	35	47	55	75	45	61	9550	70	95	65	90	50	70
	20	0.4375	0.1187	7550	55	75	40	54	60	82	50	68	10700	80	110	70	95	60	80
1/2	13	0.5000	0.1419	9050	75	102	55	75	85	116	68	92	12750	105	145	95	130	80	110
	20	0.5000	0.1599	10700	90	122	65	88	100	136	80	108	14400	120	165	110	150	90	120
9/16	12	0.5625	0.1820	11600	110	149	80	108	120	163	98	133	16400	155	210	140	190	115	155
	18	0.5625	0.2030	12950	120	163	90	122	135	184	109	148	18250	170	230	155	210	130	175
5/8	11	0.6250	0.2260	14400	150	203	110	149	165	224	135	183	20350	210	285	190	260	160	220
	18	0.6250	0.2560	16300	170	230	130	176	190	258	153	207	23000	240	323	215	290	180	245
3/4	10	0.7500	0.3340	21300	260	353	200	285	308	388	240	325	30100	375	510	340	460	280	380
	16	0.7500	0.3730	23800	300	407	220	298	330	449	268	363	33600	415	570	380	515	315	430
7/8	9	0.8750	0.4620	29400	430	583	320	434	475	646	386	523	41600	605	825	545	740	455	620
	14	0.8750	0.5090	32400	470	637	350	475	520	707	425	576	45800	670	910	600	815	500	680
1	8	1.0000	0.6060	38800	640	868	480	651	715	918	579	785	51500	860	1170	770	1045	645	875
	12	1.0000	0.6630	42200	700	949	530	719	735	1000	633	858	58700	995	1355	895	1215	745	1015
1 1/8	7	1.1250	0.7630	42300	800	1085	600	813	840	1142	714	968	68700	1290	1755	1160	1580	965	1310
	12	1.1250	0.8560	47500	860	1193	660	895	925	1259	802	1087	77000	1445	1965	1300	1770	1085	1475
1 1/4	7	1.2500	0.9690	53800	1120	1518	840	1139	1175	1598	1009	1368	87200	1815	2470	1635	2225	1365	1855
	12	1.2500	1.0730	59600	1240	1681	920	1247	1300	1768	1118	1516	96600	2015	2740	1810	2460	1510	2055
1 3/8	6	1.3750	1.1550	64100	1460	1979	1100	1491	1525	2074	1322	1792	104000	2385	3245	2145	2915	1785	2430
	12	1.3750	1.3150	73000	1680	2278	1260	1708	1750	2380	1506	2042	118100	2705	3660	2455	3310	2030	2760
1 1/2	6	1.5000	1.4050	78000	1940	2630	1460	1979	2025	2754	1755	2379	126500	3165	4305	2845	3870	2370	3225
	12	1.5000	1.5800	87700	2200	2983	1640	2224	2300	3128	1974	2676	142200	3555	4835	3200	4350	2685	3625

NO. 500059 REV. K

NOTES: 1. THESE TORQUE VALUES DO NOT APPLY TO CADMIUM PLATED FASTENERS.
 2. ALL TORQUE VALUES ARE STATIC TORQUE MEASURED PER STANDARD AUDIT METHODS TOLERANCE = ±10%
 3. * ASSEMBLY USES HARDENED WASHER

REFERENCE JLG THREAD LOCKING COMPOUND			
JLG P/N	Loctite® P/N	ND Industries P/N	Description
0100011	242™	Vibra-TITE™ 121	Medium Strength (Blue)
0100019	271™	Vibra-TITE™ 140	High Strength (Red)
0100071	262™	Vibra-TITE™ 131	Medium - High Strength (Red)

Figure 1-1. Torque Chart (SAE Fasteners - Sheet 1 of 5)

Values for Magni Coating Fasteners (Ref 4150701)																		
SAE GRADE 5 BOLTS & GRADE 2 NUTS							SAE GRADE 8 (HEX HD) BOLTS & GRADE 8 NUTS*											
Size	TPI	Bolt Dia	Tensile Stress Area	Clamp Load	Torque (Dry) K=0.17		Torque (Locitite® 242™ or 271™ OR Vibra-TITE™ 111 or 140) K=0.16		Torque (Locitite® 262™ or TITE™ 131) K=0.15		Clamp Load	Torque (Dry or Locitite® 263) K= 0.17		Torque (Locitite® 242™ or 271™ OR Vibra-TITE™ 111 or 140) K= 0.16		Torque (Locitite® 262™ or Vibra-TITE™ 131) K=0.15		
					IN-LB	[N.m]	IN-LB	[N.m]	IN-LB	[N.m]		IN-LB	[N.m]	IN-LB	[N.m]	IN-LB	[N.m]	IN-LB
4	40	0.1120	0.00604	380	7	0.8												
	48	0.1120	0.00661	420	8	0.9												
6	32	0.1380	0.00809	580	14	1.5												
	40	0.1380	0.01015	610	14	1.6												
8	32	0.1640	0.01400	900	25	2.8												
	36	0.1640	0.01474	940	26	2.9												
10	24	0.1900	0.01750	1120	36	4.1												
	32	0.1900	0.02000	1285	42	4.7												
1/4	20	0.2500	0.0318	2020	86	9.7	80	9										
	28	0.2500	0.0364	2320	99	11.1	95	11										
		In	Sq In	LB	FT-LB	[N.m]	IN-LB	[N.m]	FT-LB	[N.m]	IN-LB	[N.m]	FT-LB	[N.m]	IN-LB	[N.m]	FT-LB	[N.m]
5/16	18	0.3125	0.0524	3340	15	20	14	19	15	20	4720	20	25	20	25	20	25	25
	24	0.3125	0.0580	3700	15	20	15	21	15	20	5220	25	35	20	25	20	25	25
3/8	16	0.3750	0.0775	4940	25	35	25	34	25	34	7000	35	50	35	50	35	50	50
	24	0.3750	0.0878	5600	30	40	28	38	35	44	7900	40	55	40	55	35	50	50
7/16	14	0.4375	0.1063	6800	40	55	40	54	40	54	9550	60	80	60	80	50	70	70
	20	0.4375	0.1187	7550	45	60	44	60	40	54	10700	65	90	60	80	60	80	80
1/2	13	0.5000	0.1419	9050	65	90	60	82	55	75	12750	90	120	85	115	80	110	110
	20	0.5000	0.1599	10700	75	100	71	97	65	88	14400	100	135	95	130	90	120	120
9/16	12	0.5625	0.1820	11600	90	120	87	118	80	109	16400	130	175	125	170	115	155	155
	18	0.5625	0.2030	12950	105	145	105	132	90	122	18250	145	195	135	185	130	175	175
5/8	11	0.6250	0.2260	14400	130	175	120	163	115	156	20350	180	245	170	230	160	220	220
	18	0.6250	0.2560	16300	145	195	136	185	125	170	23000	205	280	190	260	180	245	245
3/4	10	0.7500	0.3340	21300	225	305	213	290	200	272	30100	320	435	300	410	280	380	380
	16	0.7500	0.3730	23800	255	345	238	324	225	306	33600	355	485	335	455	315	430	430
7/8	9	0.8750	0.4620	29400	365	495	343	466	320	435	41600	515	700	485	660	455	620	620
	14	0.8750	0.5090	32400	400	545	378	514	355	483	45800	570	775	535	730	500	680	680
1	8	1.0000	0.6050	38600	545	740	515	700	480	653	51500	730	995	685	930	645	875	875
	12	1.0000	0.6630	42200	600	815	563	765	530	721	59700	845	1150	795	1080	745	1015	1015
1 1/8	7	1.1250	0.7630	42300	675	920	635	863	595	809	68700	1095	1490	1030	1400	965	1310	1310
	12	1.1250	0.8560	47500	755	1025	713	969	670	911	77000	1225	1665	1155	1570	1085	1475	1475
1 1/4	7	1.2500	0.9690	53800	955	1300	897	1219	840	1142	87200	1545	2100	1455	1980	1365	1855	1855
	12	1.2500	1.0730	59600	1055	1435	1351	1351	930	1265	96600	1710	2325	1610	2190	1510	2055	2055
1 3/8	6	1.3750	1.1550	64100	1250	1700	1175	1598	1100	1496	104000	2025	2765	1905	2590	1785	2430	2430
	12	1.3750	1.3150	73000	1420	1930	1338	1820	1255	1707	118100	2290	3130	2165	2945	2030	2760	2760
1 1/2	6	1.5000	1.4050	78000	1660	2260	1560	2122	1465	1992	126500	2690	3660	2530	3440	2370	3225	3225
	12	1.5000	1.5800	87700	1865	2535	1754	2385	1645	2237	142200	3020	4105	2845	3870	2665	3625	3625

NO. 5000059 REV. K

NOTES: 1. THESE TORQUE VALUES DO NOT APPLY TO CADMIUM PLATED FASTENERS.
 2. ALL TORQUE VALUES ARE STATIC TORQUE MEASURED PER STANDARD AUDIT METHODS TOLERANCE = ±10%
 3. * ASSEMBLY USES HARDENED WASHER

Figure 1-2. Torque Chart (SAE Fasteners - Sheet 2 of 5)

SOCKET HEAD CAP SCREWS												
Size	TPI	Bolt Dia	Tensile Stress Area	Magni Coating (Ref 4150701)*				Zinc Yellow Chromate Fasteners (Ref 4150707)*				
				Clamp Load See Note 4	Torque (Dry) K = .17	Torque (Loctite® 242™ or 271™ OR Vibra-TITE™ 111 or 140 OR Precoat 85®) K=0.16	Torque (Loctite® 262™ or Vibra-TITE™ 131) K=0.15	Clamp Load See Note 4	Torque (Dry) K = .20	Torque (Loctite® 242™ or 271™ OR Vibra-TITE™ 111 or 140 OR Precoat 85®) K=0.18	Torque (Loctite® 262™ or Vibra-TITE™ 131) K=0.15	
		In	Sq In	LB	IN-LB	FT-LB	IN-LB	FT-LB	IN-LB	FT-LB	IN-LB	FT-LB
4	40	0.1120	0.00604									
	48	0.1120	0.00661									
6	32	0.1380	0.00909									
	40	0.1380	0.01015									
8	32	0.1640	0.01400									
	36	0.1640	0.01474									
10	24	0.1900	0.01750									
	32	0.1900	0.02000									
1/4	20	0.2500	0.0318	2860	122	14	114	13	131	15	129	15
	28	0.2500	0.0364	3280	139	16	131	15	148	17	148	17
		In	Sq In	LB	FT-LB	IN-LB	FT-LB	IN-LB	FT-LB	IN-LB	FT-LB	IN-LB
5/16	18	0.3125	0.0524	4720	20	25	20	25	20	25	20	25
	24	0.3125	0.0580	5220	25	35	20	25	25	35	20	25
3/8	16	0.3750	0.0775	7000	35	50	35	50	35	50	35	50
	24	0.3750	0.0878	7900	40	55	40	55	40	55	40	55
7/16	14	0.4375	0.1063	9550	60	80	55	75	50	70	65	90
	20	0.4375	0.1187	10700	65	90	60	80	60	70	65	90
1/2	13	0.5000	0.1419	12750	90	120	85	115	80	110	70	95
	20	0.5000	0.1599	14400	100	135	95	130	90	120	110	150
9/16	12	0.5625	0.1820	16400	130	175	125	170	115	140	140	190
	18	0.5625	0.2030	18250	145	195	135	185	130	175	155	210
5/8	11	0.6250	0.2260	20350	180	245	170	230	160	220	170	230
	18	0.6250	0.2560	23000	205	280	190	260	180	240	215	290
3/4	10	0.7500	0.3340	30100	320	435	300	400	280	375	340	460
	16	0.7500	0.3730	33600	355	485	335	455	315	430	380	515
7/8	9	0.8750	0.4620	41600	515	700	485	660	455	620	545	740
	14	0.8750	0.5090	45800	570	775	535	730	500	680	600	815
1	8	1.0000	0.6060	51500	730	995	685	930	645	875	775	1055
	12	1.0000	0.6630	59700	845	1150	795	1080	745	995	895	1215
1 1/8	7	1.1250	0.7630	68700	1095	1490	1030	1400	965	1310	1160	1580
	12	1.1250	0.8560	77000	1225	1665	1155	1570	1085	1475	1300	1770
1 1/4	7	1.2500	0.9690	87200	1545	2100	1455	1960	1385	1855	1635	2225
	12	1.2500	1.0730	96600	1710	2325	1610	2190	1510	2055	1810	2460
1 3/8	6	1.3750	1.1550	104000	2025	2755	1905	2590	1785	2430	2145	2915
	12	1.3750	1.3150	118100	2300	3130	2165	2945	2030	2760	2435	3310
1 1/2	6	1.5000	1.4050	126500	2690	3660	2530	3440	2370	3225	3165	4305
	12	1.5000	1.5800	142200	3020	4105	2845	3870	2665	3625	3555	4835

NO. 5000059 REV. K

NOTES: 1. THESE TORQUE VALUES DO NOT APPLY TO CADMIUM PLATED FASTENERS.
 2. ALL TORQUE VALUES ARE STATIC TORQUE MEASURED PER STANDARD AUDIT METHODS. TOLERANCE = ±10%.
 *3. ASSEMBLY USES HARDENED WASHER OR FASTENER IS PLACED AGAINST PLATED STEEL OR RAW ALUMINUM
 4. CLAMP LOAD LISTED FOR SHCS IS SAME AS GRADE 8 OR CLASS 10.9 AND DOES NOT REPRESENT FULL STRENGTH CAPABILITY OF SHCS. IF HIGHER LOAD IS REQUIRED, ADDITIONAL TESTING IS REQUIRED.

Figure 1-3. Torque Chart (SAE Fasteners - Sheet 3 of 5)

Values for Zinc Yellow Chromate Fasteners (Ref 4150707)											
CLASS 8.8 METRIC (HEX/SOCKET HEAD) BOLTS CLASS 8 METRIC NUTS					CLASS 10.9 METRIC (HEX HEAD) BOLTS CLASS 10 METRIC NUTS CLASS 12.9 SOCKET HEAD CAP SCREWS M3 - M5*						
Size	PITCH	Tensile Stress Area	Clamp Load	Torque (Dry or Loctite® 263™)	Torque (Lub)	Torque (Loctite® 262™ OR Vibra-TITE™ 131)	Torque (Loctite® 242™ or 271™ OR Vibra-TITE™ 111 or 140)	Clamp Load	Torque (Dry or Loctite® 263™) K = 0.20	Torque (Lub OR Loctite® 242™ or 271™ OR Vibra-TITE™ 111 or 140) K = 0.18	Torque (Loctite® 262™ OR Vibra-TITE™ 131) K = 0.15
		Sq mm	KN	[N.m]	[N.m]	[N.m]	[N.m]	KN	[N.m]	[N.m]	[N.m]
3	0.5	5.03	2.19	1.3	1.0	1.2	1.4	3.13			
3.5	0.6	6.78	2.95	2.1	1.6	1.9	2.3	4.22			
4	0.7	8.78	3.82	3.1	2.3	2.8	3.4	5.47			
5	0.8	14.20	6.18	6.2	4.6	5.6	6.8	8.85			
6	1	20.10	8.74	11	7.9	9.4	12	12.5			
7	1	28.90	12.6	18	13	16	19	18.0	25	23	19
8	1.25	36.60	15.9	26	19	23	28	22.8	37	33	27
10	1.5	58.00	25.2	50	38	45	55	36.1	70	65	55
12	1.75	84.30	36.7	88	66	79	97	52.5	125	115	95
14	2	115	50.0	140	105	126	154	71.6	200	180	150
16	2	157	68.3	219	164	197	241	97.8	315	280	235
18	2.5	192	83.5	301	226	271	331	119.5	430	385	325
20	2.5	245	106.5	426	320	383	469	152.5	610	550	460
22	2.5	303	132.0	581	436	523	639	189.0	830	750	625
24	3	353	153.5	737	553	663	811	222.0	1065	960	800
27	3	459	199.5	1080	810	970	1130	286.0	1545	1390	1160
30	3.5	561	244.0	1460	1100	1320	1530	349.5	2095	1885	1575
33	3.5	694	302.0	1990	1490	1790	2090	432.5	2855	2570	2140
36	4	817	355.5	2560	1920	2300	2690	509.0	3665	3300	2750
42	4.5	1120	487.0	4090	3070	3680	4290	698.0	5865	5275	4395

NO. 5000059 REV. K

NOTES: 1. THESE TORQUE VALUES DO NOT APPLY TO CADMIUM PLATED FASTENERS
 2. ALL TORQUE VALUES ARE STATIC TORQUE MEASURED PER STANDARD AUDIT METHODS TOLERANCE = ±10%
 *3. ASSEMBLY USES HARDENED WASHER OR FASTENER IS PLACED AGAINST PLATED STEEL OR RAW ALUMINUM
 4. CLAMP LOAD LISTED FOR SHCS IS SAME AS GRADE 8 OR CLASS 10.9 AND DOES NOT REPRESENT FULL STRENGTH CAPABILITY OF SHCS. IF HIGHER LOAD IS REQUIRED, ADDITIONAL TESTING IS REQUIRED.

Figure 1-4. Torque Chart (Metric Fasteners - Sheet 4 of 5)

Values for Magni Coated Fasteners (Ref 4150701)										
CLASS 8.8 METRIC (HEX/SOCKET HEAD) BOLTS CLASS 8 METRIC NUTS					CLASS 10.9 METRIC (HEX HEAD) BOLTS CLASS 10 METRIC NUTS CLASS 12.9 SOCKET HEAD CAP SCREWS M6 AND ABOVE*					
Size	PITCH	Tensile Stress Area	Clamp Load	Torque (Dry or Loctite® 263™) K=0.17	Torque (Loctite® 242™ or 271™ OR Vibra-TITE™ 131) K=0.16	Torque (Loctite® 242™ or 271™ OR Vibra-TITE™ 111 or 140) K=0.15	Clamp Load	Torque (Dry or Loctite® 263™) K=0.17	Torque (Lub OR Loctite® 242™ or 271™ OR Vibra-TITE™ 111 or 140) K=0.16	Torque (Loctite® 262™ OR Vibra-TITE™ 131) K=0.15
		Sq mm	KN	[N.m]	[N.m]	[N.m]	KN	[N.m]	[N.m]	[N.m]
3	0.5	5.03	2.19	1.1	1.1	1.0	3.13			
3.5	0.6	6.78	2.95	1.8	1.7	1.5	4.22			
4	0.7	8.78	3.82	2.6	2.4	2.3	5.47			
5	0.8	14.20	6.18	5.3	4.9	4.6	8.85			
6	1	20.10	8.74	9	8.4	7.9	12.5	13	12	11
7	1	28.90	12.6	15	14	13	18.0	21	20	19
8	1.25	36.60	15.9	22	20	19	22.8	31	29	27
10	1.5	58.00	25.2	43	40	38	36.1	61	58	55
12	1.75	84.30	36.7	75	70	66	52.5	105	100	95
14	2	115	50.0	119	110	105	71.6	170	160	150
16	2	157	68.3	186	175	165	97.8	265	250	235
18	2.5	192	83.5	256	240	225	119.5	365	345	325
20	2.5	245	106.5	362	340	320	152.5	520	490	460
22	2.5	303	132.0	494	465	435	189.0	705	665	625
24	3	353	153.5	627	590	555	222.0	905	850	800
27	3	459	199.5	916	860	810	286.0	1315	1235	1160
30	3.5	561	244.0	1245	1170	1100	349.5	1780	1680	1575
33	3.5	694	302.0	1694	1595	1495	432.5	2425	2285	2140
36	4	817	355.5	2176	2050	1920	509.0	3115	2930	2750
42	4.5	1120	487.0	3477	3275	3070	698.0	4985	4690	4395

NO. 500059 REV. K

NOTES: 1. THESE TORQUE VALUES DO NOT APPLY TO CADMIUM PLATED FASTENERS

2. ALL TORQUE VALUES ARE STATIC TORQUE MEASURED PER STANDARD AUDIT METHODS TOLERANCE = ±10%

*3. ASSEMBLY USES HARDENED WASHER OR FASTENER IS PLACED AGAINST PLATED STEEL OR RAW ALUMINUM

4. CLAMP LOAD LISTED FOR SHCS IS SAME AS GRADE 8 OR CLASS 10.9 AND DOES NOT REPRESENT FULL STRENGTH CAPABILITY OF SHCS. IF HIGHER LOAD IS REQUIRED, ADDITIONAL TESTING IS REQUIRED.

Figure 1-5. Torque Chart (Metric Fasteners - Sheet 5 of 5)

SECTION 2. GENERAL

2.1 MACHINE PREPARATION, INSPECTION, AND MAINTENANCE

General

This section provides the necessary information needed by those personnel that are responsible to place the machine in operation readiness and maintain its safe operating condition. For maximum service life and safe operation, ensure that all the necessary inspections and maintenance have been completed before placing the machine into service. With proper care, maintenance and inspections performed per JLG's recommendations with any and all discrepancies corrected, this product will be fit for continued use.

Preparation, Inspection, and Maintenance

It is important to establish and conform to a comprehensive inspection and preventive maintenance program. The following table outlines the periodic machine inspections and maintenance recommended by JLG Industries, Inc. Consult your national, regional, or local regulations for further requirements for aerial work platforms. The frequency of inspections and maintenance must be increased as environment, severity and frequency of usage requires.

Pre-Start Inspection

It is the User's or Operator's primary responsibility to perform a Pre-Start Inspection of the machine prior to use daily or at each change of operator. Reference the Operation and Safety Manual for completion procedures for the Pre-Start Inspection. The Operation and Safety Manual must be read in its entirety and understood prior to performing the Pre-Start Inspection.

Pre-Delivery Inspection and Frequent Inspection

The Pre-Delivery Inspection and Frequent Inspection shall be performed by a qualified JLG equipment mechanic. JLG Industries, Inc. recognizes a qualified JLG equipment mechanic as a person who, by possession of a recognized degree, certificate, extensive knowledge, training, or experience, has successfully demonstrated the ability and proficiency to service, repair, and maintain the subject JLG product model.

The Pre-Delivery Inspection and Frequent Inspection procedures are performed in the same manner, but at different times. The Pre-Delivery Inspection shall be performed prior to each sale, lease, or rental delivery. The Frequent Inspection shall be accomplished for each machine in service for 3 months or 150 hours (whichever comes first); out of service for a period of more than 3 months; or when purchased used. The frequency of this inspection must be increased as environment, severity and frequency of usage requires.

Reference the JLG Pre-Delivery and Frequent Inspection Form and the Inspection and Preventative Maintenance Schedule for items requiring inspection during the performance of these inspections. Reference the appropriate areas of this manual for servicing and maintenance procedures.

Annual Machine Inspection

JLG recommends that the Annual Machine Inspection be performed by a Factory-Trained Service Technician on an annual basis, no later than thirteen (13) months from the date of the prior Annual Machine Inspection. JLG Industries, Inc. recognizes a Factory-Trained Service Technician as a person who has successfully completed the JLG Service Training School for the subject JLG product model. Reference the machine Service and Maintenance Manual and appropriate JLG inspection form for performance of this inspection.

Reference the JLG Annual Machine Inspection Form and the Inspection and Preventative Maintenance Schedule for items requiring inspection during the performance of this inspection. Reference the appropriate areas of this manual for servicing and maintenance procedures.

For the purpose of receiving safety-related bulletins, it is important that JLG Industries, Inc. has updated ownership information for each machine. When performing each Annual Machine Inspection, notify JLG Industries, Inc. of the current machine ownership.

Preventative Maintenance

In conjunction with the specified inspections, maintenance shall be performed by a qualified JLG equipment mechanic. JLG Industries, Inc. recognizes a qualified JLG equipment mechanic as a person who, by possession of a recognized degree, certificate, extensive knowledge, training, or experience, has successfully demonstrated the ability and proficiency to service, repair, and maintain the subject JLG product model.

Reference the Preventative Maintenance Schedule and the appropriate areas of this manual for servicing and maintenance procedures. The frequency of service and maintenance must be increased as environment, severity and frequency of usage requires.

Table 2-1. Inspection and Maintenance Responsibilities

Type	Frequency	Primary Responsibility	Service Qualification	Reference
Pre-Start Inspection	Prior to use each day; or At each Operator change.	User or Operator	User or Operator	Operation and Safety Manual
Pre-Delivery Inspection	Prior to each sale, lease, or rental delivery.	Owner, Dealer, or User	Qualified JLG Mechanic	Service and Maintenance Manual and applicable JLG inspection form.
Frequent Inspection	In service for 3 months or 150 hours, whichever comes first; or Out of service for a period of more than 3 months; or Purchased used.	Owner, Dealer, or User	Qualified JLG Mechanic	Service and Maintenance Manual and applicable JLG inspection form.
Annual Machine Inspection	Annually, no later than 13 months from the date of the prior inspection.	Owner, Dealer, or User	Factory-Trained Service Technician (recommended)	Service and Maintenance Manual and applicable JLG inspection form.
Preventative Maintenance	At intervals as specified in the Service and Maintenance Manual.	Owner, Dealer, or User	Qualified JLG Mechanic	Service and Maintenance Manual

2.2 PREVENTIVE MAINTENANCE AND INSPECTION SCHEDULE

The preventive maintenance and inspection checks are listed and defined in the following table. This table is divided into two basic parts, the "AREA" to be inspected and the "INTERVAL" at which the inspection is to take place. Under the "AREA" portion of the table, the various systems along with the components that make up that system are listed. The "INTERVAL" portion of the table is divided into two columns representing the various inspection time periods. The numbers listed within the interval column represent the applicable inspection code for which that component is to be checked.

The checks and services listed in this schedule are not intended to replace any local or regional regulations that may pertain to this type of equipment nor should the lists be considered as all inclusive. Variances in interval times may occur due to climate and/or conditions and depending on the location and use of the machine.

NOTICE

JLG INDUSTRIES REQUIRES THAT A COMPLETE ANNUAL INSPECTION BE PERFORMED IN ACCORDANCE WITH THE "ANNUAL MACHINE INSPECTION REPORT" FORM.

NOTE: *This machine requires periodic safety and maintenance inspections by a qualified JLG mechanic. Notify JLG dealer if inspection is overdue.*

Maintenance and Inspection Schedule Codes:

1. Check for proper and secure installation.
2. Visual inspection for damage, cracks, distortion, or excessive wear.
3. Check for proper adjustment.
4. Check for cracked or broken welds.
5. Operates properly.

6. Returns to neutral or "off" position when released.
7. Clean and free of debris.
8. Interlocks function properly.
9. Check for signs of leakage.
10. Decals installed and legible.
11. Check for proper fluid level.
12. Check for chafing and proper routing.
13. Check for proper tolerances.
14. Properly lubricated.
15. Torqued to proper specification.
16. No gouges, excessive wear, or cords showing.
17. Properly inflated and seated around rim.
18. Proper and authorized components.
19. Fully charged.
20. No loose connections, corrosion, or abrasions.
21. Verify.
22. Perform.
23. Sealed properly.
24. Overrides Platform controls.
25. Remove pump motor cover and blow away any brush wear dust from cover, brushes, and brush holder assembly.

Footnotes:

- (a) Prior to each sale, lease, or delivery
- (b) In service for 3 months; or Out of service for 3 months or more; or Purchased used
- (c) Annually, no later than 13 months from the date of the prior inspection

Table 2-2. Preventive Maintenance & Inspection Schedule.

AREA ON MACHINE	INTERVAL	
	PRE-DELIVERY (a) OR FREQUENT (b) INSPECTION	ANNUAL (c) (YEARLY) INSPECTION
FUNCTIONS/CONTROLS		
Platform Controls	5,6,7	5,6,7
Ground Controls	5,6	5,6,14
Function Control Locks, Guards, or Detents	5	5
Function Enable System	5	5
Emergency Stop Switches (Ground & Platform)	5	5
Function Limit or Cutout Switch Systems	5	5
Manual Descent or Auxiliary Power	5	5
PLATFORM ASSEMBLY		
Platform	1	1
Guard Rails	1,2,4	1,2,4
Gate	1,5	1,5
Floor	1,2	1,2
Lanyard Anchorage Point	1,4,10	1,4,10
SCISSOR ARMS		
Scissor Arms	1,2,4	1,2,4
Arm Safety Prop	1,5	1,5
Cylinder Pins, Pivot Pins & Attaching Hardware	1	1
Arm Pins, Wear Pads & Attaching Hardware	1	1
CHASSIS ASSEMBLY		
Covers Installation	1,7	1,7
Static Strap	1	1
Wheel and Tire Assemblies	2,15	2,15
Drive Motors	1,7,9	1,7,9
Drive Motor Brushes**	—	—
POWER SYSTEM		
Batteries	9	18
Battery Charger		5
HYDRAULIC/ELECTRIC SYSTEM		
Hydraulic Lift/Steer Pump	1,2,9	1,2,5,9,25
Hydraulic Cylinders (arms and steering)	2,7,9	2,9
Steer Cylinder Attachment Pins and Pin Retainers	1,2	1,2
Hydraulic Hoses, Lines, and Fittings	1,9	1,9
Hydraulic Reservoir, Cap, and Breather	5,7	5,7
Hydraulic Fluid***	11	11
Electrical Connections	20	20
Instruments, Gauges, Switches, Lights, Horn	5	5

Table 2-2. Preventive Maintenance & Inspection Schedule. (Continued)

AREA ON MACHINE	INTERVAL	
	PRE-DELIVERY (a) OR FREQUENT (b) INSPECTION	ANNUAL (c) (YEARLY) INSPECTION
GENERAL		
Operation & Safety Manual in Storage Box	21	21
ANSI & EMI Handbooks in Storage Box (ANSI ONLY)	21	21
Capacity Decals Installed, Secure, Legible	21	21
All Decals/Placards Installed, Secure, Legible	21	21
Annual Machine Inspection Due		21
No Unauthorized Modifications or Additions	21	21
All Relevant Safety Publications Incorporated	21	21,22
General Structural Condition and Welds	2,4	2,4
All Fasteners, Pins, Shields, and Covers		1,2
Grease and Lubricate to Specifications	22	22
Function Test of All Systems	22	22
Paint and Appearance	7	7
Notify JLG of change in Machine Ownership		22
** Replace when system performance is degraded. *** Every two years, drain and remove hydraulic oil reservoir , clean pick-up screen, refill with fresh hydraulic fluid.		

2.3 SERVICE AND GUIDELINES

General

The following information is provided to assist you in the use and application of servicing and maintenance procedures contained in this book.

Safety and Workmanship

Your safety, and that of others, is the first consideration when engaging in the maintenance of equipment. Always be conscious of weight. Never attempt to move heavy parts without the aid of a mechanical device. Do not allow heavy objects to rest in an unstable position. When raising a portion of the equipment, ensure that adequate support is provided.

Cleanliness

1. The most important single item in preserving the long service life of a machine is to keep dirt and foreign materials out of the vital components. Precautions have been taken to safeguard against this. Shields, covers, seals, and filters are provided to keep air, fuel, and oil supplies clean; however, these items must be maintained on a scheduled basis in order to function properly.
2. At any time when air, fuel, or oil lines are disconnected, clean adjacent areas as well as the openings and fittings themselves. As soon as a line or component is disconnected, cap or cover all openings to prevent entry of foreign matter.
3. Clean and inspect all parts during servicing or maintenance, and assure that all passages and openings are unobstructed. Cover all parts to keep them clean. Be sure all parts are clean before they are installed. New parts should remain in their containers until they are ready to be used.

Components Removal and Installation

1. Use adjustable lifting devices, whenever possible, if mechanical assistance is required. All slings (chains, cables, etc.) should be parallel to each other and as near perpendicular as possible to top of part being lifted.
2. Should it be necessary to remove a component on an angle, keep in mind that the capacity of an eyebolt or similar bracket lessens, as the angle between the supporting structure and the component becomes less than 90°.
3. If a part resists removal, check to see whether all nuts, bolts, cables, brackets, wiring, etc., have been removed and that no adjacent parts are interfering.

Component Disassembly and Reassembly

When disassembling or reassembling a component, complete the procedural steps in sequence. Do not partially disassemble or assemble one part, then start on another. Always recheck your work to assure that nothing has been overlooked. Do not make any adjustments, other than those recommended, without obtaining proper approval.

Pressure-Fit Parts

When assembling pressure-fit parts, use an anti-seize or molybdenum disulfide base compound to lubricate the mating surface.

Bearings

1. When a bearing is removed, cover it to keep out dirt and abrasives. Clean bearings in nonflammable cleaning solvent and allow to drip dry. Compressed air can be used but do not spin the bearing.
2. Discard bearings if the races and balls (or rollers) are pitted, scored, or burned.
3. If bearing is found to be serviceable, apply a light coat of oil and wrap it in clean (waxed) paper. Do not unwrap reusable or new bearings until they are ready to install.
4. Lubricate new or used serviceable bearings before installation. When pressing a bearing into a retainer or bore, apply pressure to the outer race. If the bearing is to be installed on a shaft, apply pressure to the inner race.

Gaskets

Check that holes in gaskets align with openings in the mating parts. If it becomes necessary to hand-fabricate a gasket, use gasket material or stock of equivalent material and thickness. Be sure to cut holes in the right location, as blank gaskets can cause serious system damage.

Bolt Usage and Torque Application

1. Self locking fasteners, such as nylon insert and thread deforming locknuts, are not intended to be reinstalled after removal. Always use new replacement hardware when installing locking fasteners.
2. Use bolts of proper length. A bolt which is too long will bottom before the head is tight against its related part. If a bolt is too short, there will not be enough thread area to engage and hold the part properly. When replacing bolts, use only those having the same specifications of the original, or one which is equivalent.
3. Unless specific torque requirements are given within the text, standard torque values should be used on heat-treated bolts, studs, and steel nuts, in accordance with recommended shop practices. (See Torque Chart Section 1.)

Hydraulic Lines and Electrical Wiring

Clearly mark or tag hydraulic lines and electrical wiring, as well as their receptacles, when disconnecting or removing them from the unit. This will assure that they are correctly reinstalled.

Hydraulic System

1. Keep the system clean. If evidence of metal or rubber particles are found in the hydraulic system, drain and flush the entire system.
2. Disassemble and reassemble parts on a clean work surface. Clean all metal parts with non-flammable cleaning solvent. Lubricate components, as required, to aid assembly.

Lubrication

Service applicable components with the amount, type, and grade of lubricant recommended in this manual, at the specified intervals. When recommended lubricants are not available, consult your local supplier for an equivalent that meets or exceeds the specifications listed.

Battery

Clean battery, using a non-metallic brush and a solution of baking soda and water. Rinse with clean water. After cleaning, thoroughly dry battery and coat terminals with an anti corrosion compound.

2.4 LUBRICATION AND INFORMATION

Hydraulic System

1. The primary enemy of a hydraulic system is contamination. Contaminants enter the system by various means, e.g., using inadequate hydraulic oil, allowing moisture, grease, filings, sealing components, sand, etc., to enter when performing maintenance, or by permitting the pump to cavitate due to insufficient quantity of oil in supply tube.
2. The design and manufacturing tolerances of the component working parts are very close, therefore, even the smallest amount of dirt or foreign matter entering a system can cause wear or damage to the components and generally results in faulty operation. Every precaution must be taken to keep hydraulic oil clean, including reserve oil in storage. Hydraulic system filters should be checked, cleaned, and/or replaced as necessary, at the specified intervals required. Always examine filters for evidence of metal particles.
3. Cloudy oils indicate a high moisture content which permits organic growth, resulting in oxidation or corrosion. If this condition occurs, the system must be drained, flushed, and refilled with clean oil.
4. It is not advisable to mix oils of different brands or types, as they may not contain the same required additives or be of comparable viscosities. Good grade mineral oils, with viscosities suited to the ambient temperatures in which the machine is operating, are recommended for use.

NOTE: *Metal particles may appear in the oil or filters of new machines due to the wear-in of meshing components.*

Hydraulic Oil

1. Refer to Section 1 for recommendations for viscosity ranges.
2. JLG recommends DTE10 or Excel 15 hydraulic oil, which has an SAE viscosity of 10W-30 and a viscosity index of 152.

NOTE: *Start-up of hydraulic system with oil temperatures below -15°F (-26°C) is not recommended. If it is necessary to start the system in a sub-zero environment, it will be necessary to heat the oil with a low density, electrical heater to a minimum temperature of -15°F (-26°C).*

Changing Hydraulic Oil

1. Use of any of the recommended crankcase or hydraulic oils eliminates the need for changing the oil on a regular basis. However, filter elements must be changed annually unless operating in extreme conditions. If it is necessary to change the oil, use only those oils meeting or exceeding the specifications appearing in this manual. If unable to obtain the same type of oil supplied with the machine, consult local supplier for assistance in selecting the proper equivalent. Avoid mixing petroleum and synthetic base oils. JLG Industries recommends changing the hydraulic oil annually.
2. Use every precaution to keep the hydraulic oil clean. If the oil must be poured from the original container into another, be sure to clean all possible contaminants from the service container. Always replace the filter and clean magnet any time the system oil is changed.
3. While the unit is shut down, a good preventive maintenance measure is to make a thorough inspection of all hydraulic components, lines, fittings, etc., as well as a functional check of each system, before placing the machine back in service.

NOTE: Refer to section 4 for oil checking and oil changing procedure.

Lubrication Specifications

Specified lubricants, as recommended by the component manufacturers, are always the best choice, however, multi-purpose greases usually have the qualities which meet a variety of single purpose grease requirements. Should any question arise, regarding the use of greases in maintenance stock, consult your local supplier for evaluation. Refer to Section 1, Table 1-11, Lubrication Specifications for an explanation of the lubricant key designations.

2.5 CYLINDER DRIFT TEST

Maximum acceptable cylinder drift is to be measured using the following methods.

Platform Drift

Measure the drift of the platform to the ground. Fully extend the scissor arms from stowed position with the rated load in the platform and power off. Maximum allowable drift is 2 in (5 cm) in 10 minutes. If the machine does not pass this test, proceed with the following.

Cylinder Drift

Table 2-3. Cylinder Drift

CYLINDER BORE DIAMETER		MAX. ACCEPTABLE DRIFT IN 10 MINUTES	
inches	mm	inches	mm
3	76.2	0.026	0.66
3.5	89	0.019	0.48
4	101.6	0.015	0.38
5	127	0.009	0.22
6	152.4	0.006	0.15
7	177.8	0.005	0.13

Drift is to be measured at the cylinder rod with a calibrated dial indicator. The cylinder oil must be at ambient temperature and temperature stabilized.

The cylinder must have the normal load, which is the normal platform load applied.

If the cylinder passes this test, it is acceptable.

NOTE: This information is based on 6 drops per minute cylinder leakage.

2.6 PINS AND COMPOSITE BEARING REPAIR GUIDELINES

Filament wound bearings.

1. Pinned joints should be disassembled and inspected if the following occurs:
 - a. Excessive sloppiness in joints.
 - b. Noise originating from the joint during operation.
2. Filament wound bearings should be replaced if any of the following is observed:
 - a. Frayed or separated fibers on the liner surface.
 - b. Cracked or damaged liner backing.
 - c. Bearings that have moved or spun in their housing.
 - d. Debris embedded in liner surface.
3. Pins should be replaced if any of the following is observed (pin should be properly cleaned prior to inspection):
 - a. Detectable wear in the bearing area.
 - b. Flaking, peeling, scoring, or scratches on the pin surface.
 - c. Rusting of the pin in the bearing area.
4. Re-assembly of pinned joints using filament wound bearings.
 - a. Housing should be blown out to remove all dirt and debris, bearings and bearing housings must be free of all contamination.
 - b. Bearing / pins should be cleaned with a solvent to remove all grease and oil...filament wound bearings are dry joints and should not be lubricated.
 - c. Pins should be inspected to ensure it is free of burrs, nicks, and scratches which would damage the bearing during installation and operation.

SECTION 3. CHASSIS & SCISSOR ARMS

3.1 MACHINE COMPONENT COVERS

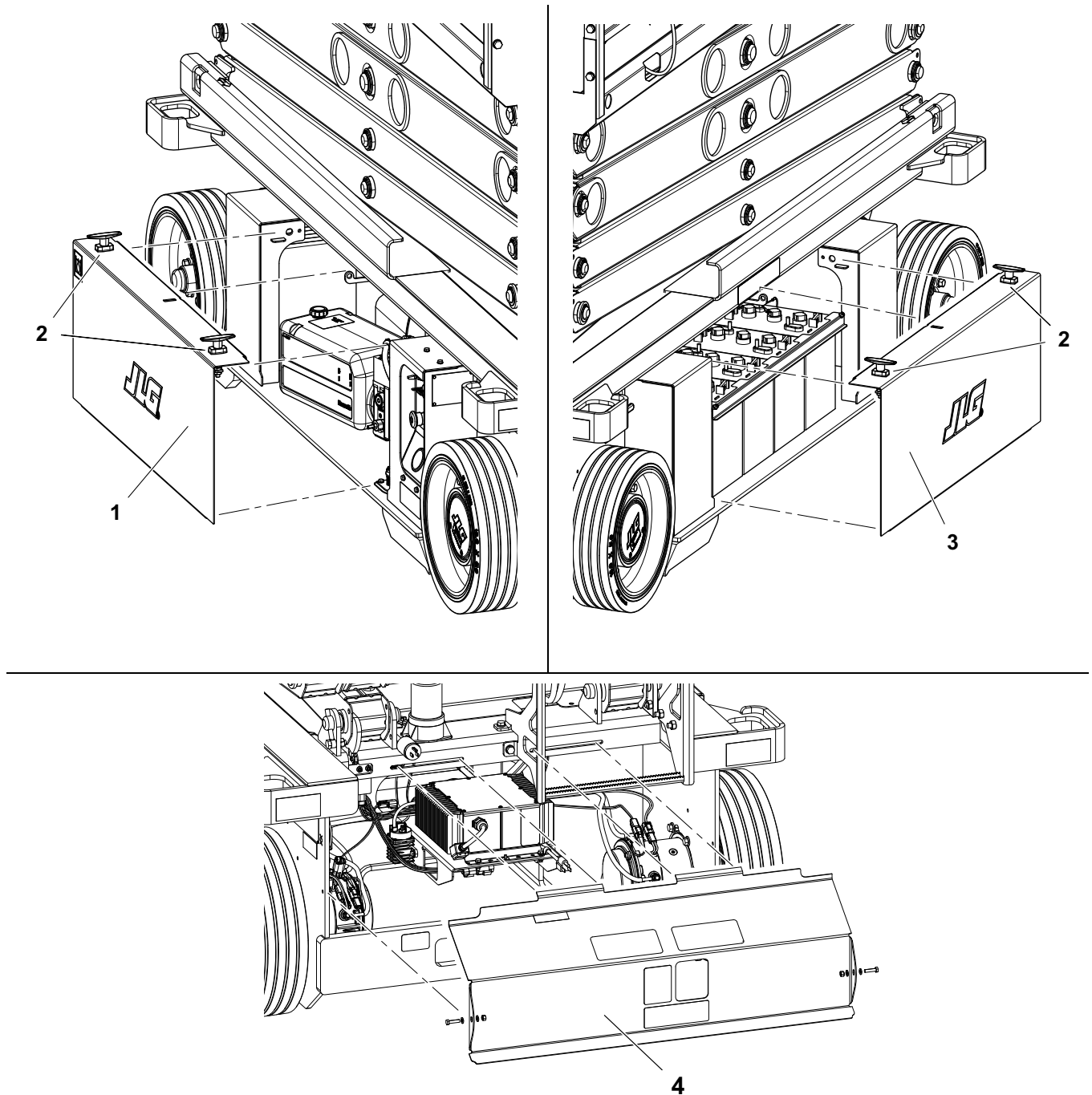

Figure 3-1. Machine Frame Covers (All Models)

- 1. Left Side (Hydraulic) Frame Cover
- 2. Side Cover Release Handles
- 3. Right Side (Batteries) Frame Cover
- 4. Rear (Drive Motor/Charger/Control Module) Cover

3.2 BATTERY REMOVAL/MAINTENANCE

NOTICE

JLG MACHINES EQUIPPED WITH DELTA Q BATTERY CHARGERS ARE DESIGNED FOR THE BEST PERFORMANCE WITH OEM FACTORY APPROVED BATTERIES. APPROVED JLG REPLACEMENT BATTERIES ARE AVAILABLE THROUGH JLG'S AFTERMARKET PARTS DISTRIBUTION CENTERS OR JLG'S AFTERMARKET PROGRAMS. FOR ASSISTANCE WITH PROPER BATTERY REPLACEMENT, PLEASE CONTACT YOUR LOCAL JLG SUPPORT OFFICE.

BATTERIES APPROVED BY JLG HAVE BEEN TESTED FOR COMPATIBILITY WITH THE ALGORITHM PROGRAMMING OF THE DELTA Q BATTERY CHARGER TO OPTIMIZE BATTERY LIFE AND MACHINE CYCLE TIMES. THE USE OF NON APPROVED BATTERIES IN YOUR JLG EQUIPMENT MAY RESULT IN PERFORMANCE ISSUES OR BATTERY CHARGER FAULT CODES. JLG ASSUMES NO RESPONSIBILITY FOR SERVICE OR PERFORMANCE ISSUES ARISING FROM THE USE OF NON APPROVED BATTERIES.

Battery Quick-Disconnect - (If Equipped)

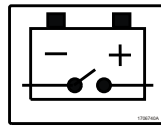

Machines equipped with the battery quick-disconnect allow all machine power to be easily disconnected at the batteries without removing battery cables from the battery posts. To disconnect power, locate the RED quick-disconnect connector on top of the batteries inside the battery compartment and pull halves apart.

CAUTION

BEFORE BATTERY REMOVAL CAN BEGIN, ENSURE THAT THE (+) AND (-) BATTERY CABLES HAVE BEEN PROPERLY DISCONNECTED.

1. The machine batteries are located inside the machine right side cover, remove the cover.
2. Once the battery door is removed from the machine, battery replacement/maintenance can begin.
3. To remove one or more batteries from the machine, the battery hold down bar will need to be removed. (See Figure 3-2.)
4. Remove the (2) nuts and washers from each hold-down anchor at the ends of the hold-down bar. Remove the bar and lay aside.
5. After battery removal and installation re-install the battery hold down bar.
6. After any maintenance on the batteries or replacement of the batteries is complete, reconnect the batteries and check for proper operation.
7. Re-install the machine right side cover.

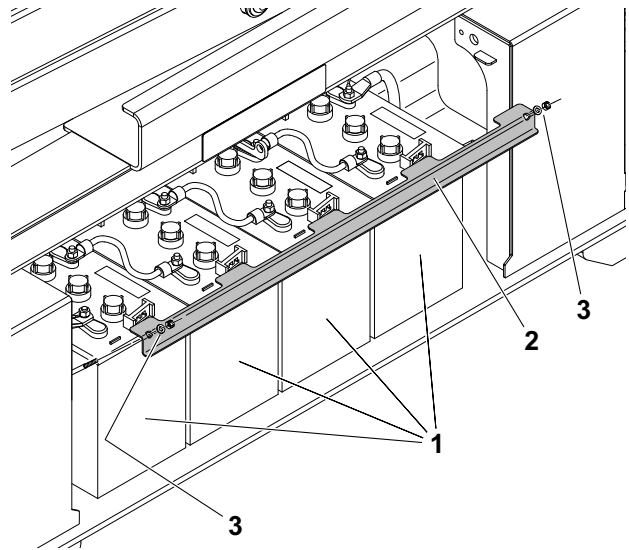

Figure 3-2. Battery Location and Hold Down Bar (All Models)

1. Batteries (4 - 6V)
2. Hold-Down Bar
3. Hold-Down Bar Fasteners

Battery Maintenance and Safety Practices

CAUTION

ENSURE THAT BATTERY ACID DOES NOT COME INTO CONTACT WITH SKIN OR CLOTHING. WEAR PROTECTIVE CLOTHING AND EYEWEAR WHEN WORKING WITH BATTERIES. NEUTRALIZE ANY BATTERY ACID SPILLS WITH BAKING SODA AND WATER.

BATTERY ACID RELEASES AN EXPLOSIVE GAS WHILE CHARGING, ALLOW NO OPEN FLAMES, SPARKS OR LIGHTED TOBACCO PRODUCTS IN THE AREA WHILE CHARGING BATTERIES. CHARGE BATTERIES ONLY IN A WELL VENTILATED AREA.

ADD ONLY DISTILLED WATER TO BATTERIES. WHEN ADDING WATER TO THE BATTERIES, A NON-METALLIC CONTAINER AND/OR FUNNEL MUST BE USED.

WARNING

DO NOT REPLACE ITEMS CRITICAL TO STABILITY, SUCH AS BATTERIES, WITH ITEMS OF DIFFERENT WEIGHT OR SPECIFICATION. DO NOT MODIFY UNIT IN ANY WAY TO AFFECT STABILITY.

Check the electrolyte level of the batteries often, adding only distilled water when required. When fully charged, battery fluid level should be 1/8" below vent tubes. (See Figure 3-3.).

- DO NOT fill to bottom of vent tubes.
- DO NOT allow fluid level to go below the top of the plates when charging or operating.
- Clean terminal connections if they become corroded.

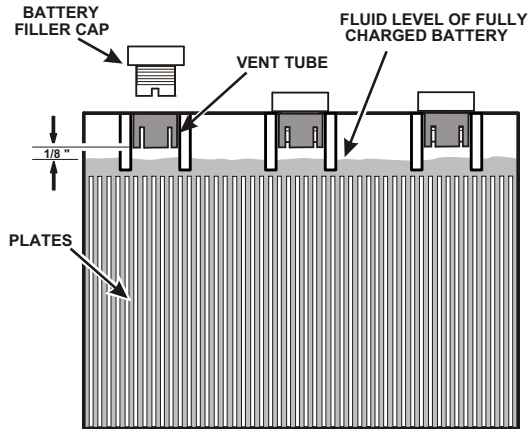
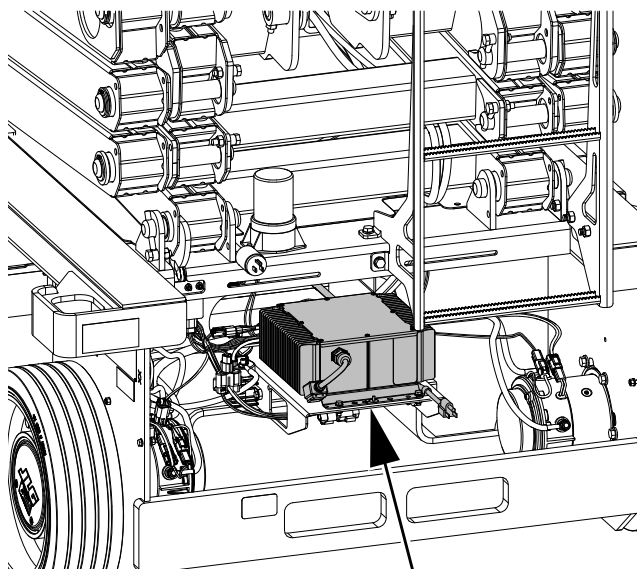

Figure 3-3. Battery Fluid Level

3.3 BATTERY CHARGER

The Battery Charger is located at the rear of the machine under the rear access cover, remove the cover to gain access to the charger.



Battery Charger Location

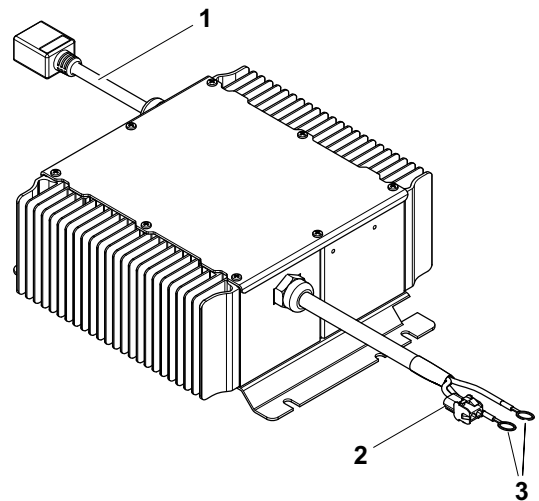

1. AC Voltage - Input Cable
2. Charger Interlock Cable
3. DC Power Cable to Batteries

Figure 3-4. Battery Charger (Delta Q)

Table 3-1. Battery Charger Specs (Delta Q)

BATTERY CHARGER	SPECIFICATION
OUTPUT	
Nominal DC Output Voltage	24V
Maximum DC Output Voltage	33.6V
Maximum DC Output Current	25A
Maximum Interlock Current	1A
INPUT	
AC Input Voltage	85-265VAC
Nominal AC Input Voltage	120VAC - 230VACRMS
AC Input Frequency	45-65 HZ
Maximum AC Input Current	12A RMS@108VAC
OPERATION	
Charging Indicator	Yellow LED
Battery Fault Indicator	Flashing Yellow LED
100% Charge Indicator	Green LED
Charger Fault Indicator	Red LED
PROTECTION	
Output Reverse Polarity	Electronic Protection - Automatic Reset
Output Short Circuit	Electronic Protection - Automatic Reset
AC Overload	Current Limited
DC Overload	Current Limited
MECHANICAL	
Operating Temperature	-22°F to +122°F (-30°C to +50°C)
Housing	Shock and Water Resistant Aluminum

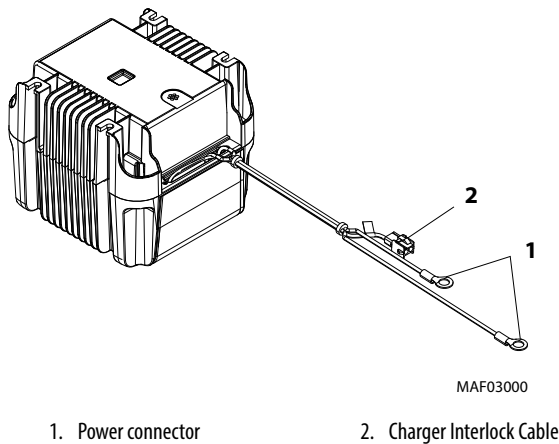

1. Power connector 2. Charger Interlock Cable

Figure 3-5. Battery Charger (Green Power)

Table 3-2. Battery Charger (Green Power)

BATTERY CHARGER	SPECIFICATION
OUTPUT	
Nominal DC Output Voltage	24V
Maximum DC Output Voltage	34V
Maximum DC Output Current	30A
INPUT	
AC Input Voltage	100-240V
AC Input Frequency	45-65 HZ
Maximum AC Input Current	8.5A
OPERATION	
Charging Indicator	Yellow LED
100% Charge Indicator	Green LED

3.4 BATTERY CHARGING

NOTE: Be sure that machine is parked in a well ventilated area before charging begins.

⚠ CAUTION

ONLY PLUG THE CHARGER INTO A PROPERLY INSTALLED AND GROUNDED OUTLET. DO NOT USE GROUND ADAPTORS OR MODIFY PLUG. DO NOT TOUCH NON-INSULATED PORTION OF OUTPUT CONNECTOR OR NON-INSULATED BATTERY TERMINAL.

DO NOT OPERATE CHARGER IF THE AC SUPPLY CORD IS DAMAGED OR IF THE CHARGER HAS RECEIVED A SHARP BLOW, BEEN DROPPED, OR OTHERWISE DAMAGED IN ANY WAY.

ALWAYS DISCONNECT THE CHARGER AC SUPPLY BEFORE MAKING OR BREAKING THE (POS/NEG) CONNECTIONS TO THE BATTERY.

DO NOT OPEN OR DISASSEMBLE CHARGER.

1. The battery charger AC input plug is located in an opening on the panel at the lower rear of the machine.
2. Connect the charger AC input plug to a grounded outlet using a 3 wire heavy duty extension cord. (See Table 3-1, Battery Charger Specs (Delta Q), for battery charger AC input specifications.)
3. When powered up the charger will go through a short LED indicator self-test. The battery charger LED indicators on the charger (Figure 3-6.), will flash in sequence for two seconds. These LED indicators can be viewed through the opening on the rear panel where the charger AC cord is accessed.
4. The batteries are fully charged when the green light on the battery charger status panel is illuminated.

NOTE: If the charger is left plugged in, the charger will automatically restart a complete charge cycle if the batteries voltage drops below a minimum voltage or 30 days has elapsed.

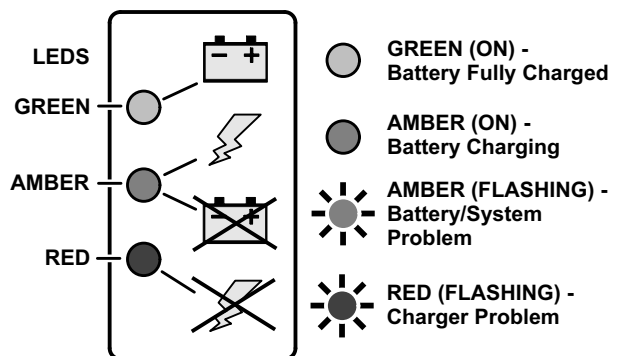

Figure 3-6. Charger Decal LED Indicators

Battery Charger Fault (LED Flash)

If a fault has occurred during battery charging, the (AMBER or RED) LED on the charger LED indicator will flash corresponding to the fault which occurred.

If required, general and troubleshooting information about the battery charger can be found in the charger manufacturers Owner's Guide. Refer www.jlg.com for below supplement manual

- TROUBLESHOOTING GUIDE - PN 3128829

Battery Charger Maintenance

⚠ WARNING

USE CHARGER ONLY ON BATTERY SYSTEMS WITH AN ALGORITHM SELECTED THAT IS APPROPRIATE TO THE SPECIFIC BATTERY TYPE. OTHER USAGE MAY CAUSE PERSONAL INJURY AND DAMAGE.

LEAD ACID BATTERIES MAY GENERATE EXPLOSIVE HYDROGEN GAS DURING NORMAL OPERATION. KEEP SPARKS, FLAMES, AND SMOKING MATERIALS AWAY FROM BATTERIES. PROVIDE ADEQUATE VENTILATION DURING CHARGING. NEVER CHARGE A FROZEN BATTERY.

STUDY ALL BATTERY MANUFACTURERS' SPECIFIC PRECAUTIONS SUCH AS RECOMMENDED RATES OF CHARGE AND REMOVING OR NOT REMOVING CELL CAPS WHILE CHARGING.

⚠ CAUTION

ONLY PLUG THE CHARGER INTO A PROPERLY INSTALLED AND GROUNDED OUTLET. DO NOT USE GROUND ADAPTORS OR MODIFY PLUG. DO NOT TOUCH NON-INSULATED PORTION OF OUTPUT CONNECTOR OR NON-INSULATED BATTERY TERMINAL.

DO NOT OPERATE CHARGER IF THE AC SUPPLY CORD IS DAMAGED OR IF THE CHARGER HAS RECEIVED A SHARP BLOW, BEEN DROPPED, OR OTHERWISE DAMAGED IN ANY WAY.

ALWAYS DISCONNECT THE CHARGER AC SUPPLY BEFORE MAKING OR BREAKING THE (POS/NEG) CONNECTIONS TO THE BATTERY.

DO NOT OPEN OR DISASSEMBLE CHARGER.

1. For flooded lead-acid batteries, regularly check water levels of each battery cell after charging and add distilled water as required to level specified by battery manufacturer. Follow the safety instructions recommended by the battery manufacturer.
2. Make sure charger connections to battery terminals are tight and clean.
3. Do not expose charger to oil or to direct heavy water spraying when cleaning vehicle.

Battery Charger Troubleshooting

NO LIGHTS AT ALL

No Lights at all indicate that AC power to the charger is not connected or that the AC voltage is too low. It could also indicate an internal failure in the charger.

1. Check the connections to AC power. Check for AC voltage between 90 and 260 VAC at the charger.
2. If the AC voltage is verified to be correct at the connection to the charger, and the charger still displays no lights at all, return the charger for service.

FAULT LED FLASHING

The Fault LED flashes to indicate the micro-controller inside the battery charger has detected a fault. The fault detected is indicated by the number of flashes. Count the number of flashes to determine the fault.

With any battery system, the most common problem will be a faulty battery connection. Because of the high likelihood of a battery connection problem, it is always worthwhile to confirm that all connections are good before checking for any other problems.

[1 Flash] - High Battery Voltage

1. Indicates a high battery voltage. Check that the battery charger voltage is consistent with the battery pack voltage. The first two digits of the four digit model name indicate the battery voltage the charger supports.
2. Check for wiring errors.
3. This fault will automatically clear and the charger will restart charging when this problem is removed.
4. High battery voltage could also occur if there is another source charging the battery. Disconnect any other sources during charging.
5. If this problem does not clear after the battery voltage is confirmed to be less than 2.4V per cell, return the charger for service.

[2 Flashes] - Low Battery Voltage

1. Indicates either a battery failure, no battery connected, or a lower than expected battery voltage. Check the battery and battery connections.
2. Check the nominal battery voltage. The first two digits of the four digit model name indicate the battery voltage the charger supports. Confirm that a nominal battery voltage is the same as the charger voltage.
3. This fault will clear automatically when the low battery voltage problem is rectified.

4. If this problem does not clear after the battery voltage is confirmed to be higher than 1.0V per cell and all connections are good, return the charger for service.

[3 Flashes] - Charge Time-out

Indicates the battery failed to charge within the allowed time. This could occur if the battery is of larger capacity than the algorithm is intended for. In unusual cases it could mean charger output is reduced due to high ambient temperature. It can also occur if the battery is damaged, old, or in poor condition.

1. Check the battery for damage such as shorted cells and insufficient water. Try the charger on a good battery.
2. If the same fault occurs on a good battery, check the connections on the battery and connection to AC, and the AC voltage itself.
3. Confirm that the nominal battery pack voltage is the same as the battery charger voltage.
4. This fault must be cleared manually by unplugging the AC, waiting 30 seconds and reconnecting the AC power.
5. If a charger displays this fault on a battery pack, and the pack is of questionable status, reset the charger by disconnecting AC for 30 seconds, and then reconnect the AC to start a new charge cycle. After a few charge cycles, this problem could stop occurring as the pack "recovers."

[4 Flashes] - Check Battery

This fault indicates the battery pack could not be trickle charged up to the minimum level required for the normal charge cycle to be started.

1. Check that none of the battery pack connections between modules are reversed or incorrectly connected.
2. Check that one or more cells in the battery are not shorted.
3. Confirm that the nominal battery pack voltage is the same as the battery charger voltage.
4. Try the charger on a good battery.
5. If this fault occurs, the battery is likely in poor condition. Try to recover the pack with a charger that can charge the individual cells - such as an automotive charger. Be sure to set this charger to the appropriate voltage - 6V per 6V battery, 12V per 12V string/battery.

[5 Flashes] - Over Temperature

This fault indicates the charger has become too hot during operation. Though not damaging to the charger, charge time will be extended significantly.

1. This fault indication will not clear automatically, but the charger will restart charging automatically when the temperature drops. The fault indication must be cleared manually by unplugging the AC, waiting 30 seconds and reconnecting the AC power.
2. If possible, move the machine to a cooler location.
3. Confirm that dirt or mud is not blocking the cooling fins of the charger. Clean the charger. Rinse the charger with a low pressure hose if required. Do not use high pressure. Do not use a pressure washer.

[6 Flashes] - Over Load/Over Temperature

This fault indicates that the batteries will not accept charge current, or an internal fault has been detected in the charger. This fault will nearly always be set within the first 30 seconds of operation. If it occurs after the charger has started charging normally, complete the following steps.

1. Try to clear the fault by unplugging the AC, waiting 30 seconds and reconnecting the ac power.
2. Check all battery connections. Look for a high resistance connection. The most likely reason for this fault is a fault in the battery such as a bad battery connection, an open cell, or insufficient water.
3. This fault will occur if an internal fuse inside the charger blows. If the green wire is shorted to ground even momentarily, this fuse will blow. To check the fuse, measure with an ohmmeter between the green and red wires with the AC disconnected. If a short circuit is not measured, the fuse has blown. Return unit to a service depot to have this fuse replaced.
4. If this fault occurs after battery charging has started, confirm that AC power was not interrupted and that all battery connections are good.
5. If all battery connections are good, an internal fault has been detected and the charger must be brought to a qualified service depot.

Excessive Battery Watering Requirements or Strong Sulphur (Rotten Egg) Smell

These symptoms indicate over-charging or high battery temperature. These symptoms are unlikely to be caused by too high a charge current since the maximum charge current of the charger will be small compared to even a moderately sized battery pack. The most likely cause for this problem is incorrect charge algorithm setting and/or high ambient temperatures. For correct charge algorithm setting, refer www.jlg.com for below supplement manual

- TROUBLESHOOTING GUIDE - PN 3128829

3.5 DC TO AC INVERTER (IF EQUIPPED)

Inverter Location on Machine

The inverter is located to the right rear of the machine in the battery side compartment on all RS Scissor models.

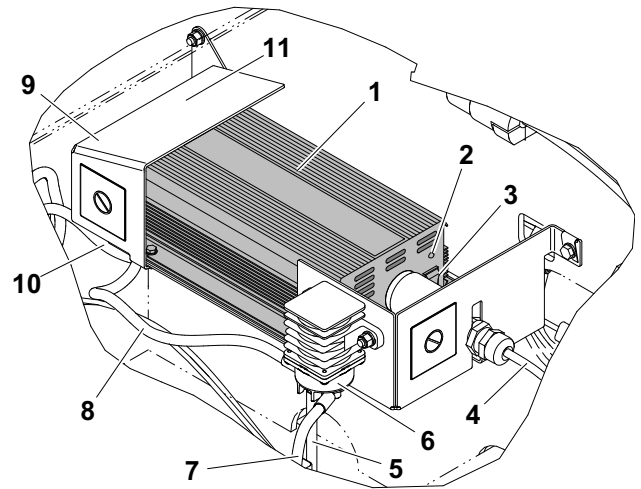

- | | |
|---|---|
| 1. DC to AC Inverter | 6. Inverter Power Relay |
| 2. Overload LED Indicator | 7. From VDC Battery POS (+) |
| 3. Inverter Internal ON/OFF Switch - Set to ON from factory | 8. To VDC Inverter POS (+) Input |
| 4. Inverter VAC Output Cord | 9. External DC 25A Replaceable Fuse(s)* |
| 5. To Inverter ON/OFF Switch at Ground Control Panel | 10. From VDC Battery NEG (-)* |
| | 11. Inverter Cooling Fan* |

Figure 3-7. DC to AC Inverter Components

*Items located under shield.

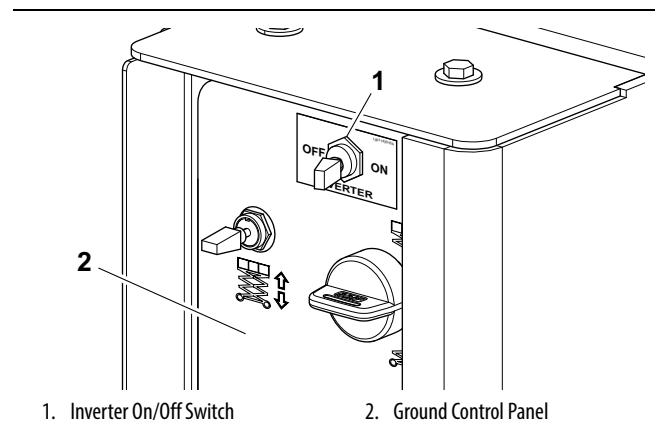

- | | |
|---------------------------|-------------------------|
| 1. Inverter On/Off Switch | 2. Ground Control Panel |
|---------------------------|-------------------------|

Figure 3-8. Inverter On/Off Switch Location

Inverter Operation



DANGER OF SHOCK OR ELECTROCUTION - TREAT INVERTER OUTPUT THE SAME AS COMMERCIAL AC POWER.

If servicing remove any frame covers required to gain access to the inverter unit.

1. Turn ON the inverter at the ground control station inverter ON/OFF switch. *(Make certain the overload LED is not lit on the inverter.)*
2. Turn OFF the inverter. The overload LED may briefly "blink" and the audible alarm may also sound a short "chirp". This is normal.
3. When you have confirmed that the appliance (tool) to be operated is turned off, plug the appliance cord into the inverter AC output cord.
4. Turn ON the inverter.
5. Turn on the appliance (tool).
6. Plug in any additional appliances (tools).

NOTE: *The audible alarm may make a momentary "chirp" when the inverter is turned OFF. This same alarm may also sound when the inverter is being connected to or disconnected from the 24 volt battery bank.*

Inverter Specifications

Name	Description
DC Input	24V (20-30V) DC
AC Output	110V AC
Output Waveform	Modified Sine Wave (MSW)
Continuous Power	900 Watt
Surge Power	1800 Watt
Efficiency	Aprox. 90%
Power Switch	ON/OFF Control
Power Switch OFF	<0.5 ADC
Battery Low Alarm	21 ± 0.5 VDC
Battery Low Shutdown	20 ± 0.5 VDC
AC Output Sockets	(2) North American Std. 7.5 Amps
External Fuses	3 x 25 Amp (Automotive Spade Type)
Dimensions	5 in. (W) x 2.75 in. (H) x 10.5 in. (D) (12,7cm x 7cm x 26,67cm)
Net Weight	6 lbs. (2,72 Kg)

NOTE: *All specifications are typical at nominal line, half load, and 77° F (25° C) unless otherwise specified. Specifications are subject to change without notice.*

Inverter Troubleshooting

Problem: No Input Voltage	
Poor contact with battery terminals.	Shut down the inverter and disconnect battery power. Clean terminals thoroughly and reconnect.
Blown DC battery fuse(s).	Turn off inverter. Replace fuse(s) with the same type and rating.
Problem: Inverter Is In Shut Down	
Battery voltage is below 20 volts.	Charge or replace battery.
Inverter is too hot (thermal shut down mode). Overload LED indicator on inverter is lit ORANGE/RED.	Allow inverter to cool. Check for adequate ventilation. Reduce the load on the inverter to rated continuous power.
Unit may be defective.	See warranty and call customer service.
Problem: Low Battery Alarm On All The Time	
Input voltage below 21 volts - buzzing sound.	Keep input voltage above 21 volts to maintain regulation.
Poor or weak battery condition.	Recharge or replace battery(s).
Inadequate power being delivered to the inverter or excessive voltage drop.	Use lower gauge (heavier) cable. Keep cable length as short as possible.

3.6 GROUND CONTROL STATION

NOTICE

DISCONNECT MAIN POWER FROM THE BATTERIES BEFORE ATTEMPTING TO REMOVE THE GROUND CONTROL PANEL OR SERVICING THE ELECTRICAL SYSTEM. FAILURE TO DO SO COULD CAUSE DAMAGE TO THE MACHINES ELECTRICAL COMPONENTS.

Components Location

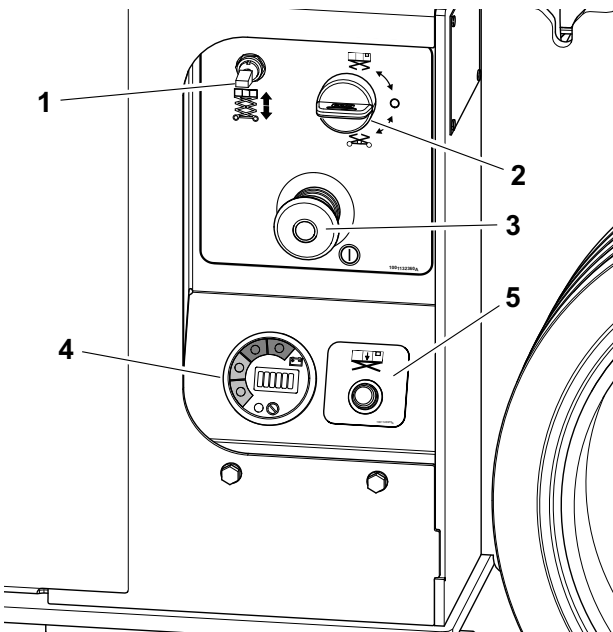

Figure 3-9. Ground Control Station Component Location (All Models)

- | | |
|--------------------------------|-------------------------------------|
| 1. Platform Lift/Lower Switch | 4. MDI - Indicator |
| 2. Key Selector Switch | 5. Overload Indicator (If Equipped) |
| 3. Ground Emergency StopButton | |

Removal (All Models)

1. Disconnect main power at the batteries.
2. Remove the machine side cover on the left side of the machine (ground control station/pump side).
3. Remove the (4) screws and washers attaching the ground control panel to the frame.
4. When panel is released, rotate and position to unplug or disconnect the desired connectors and components on the back of the panel.

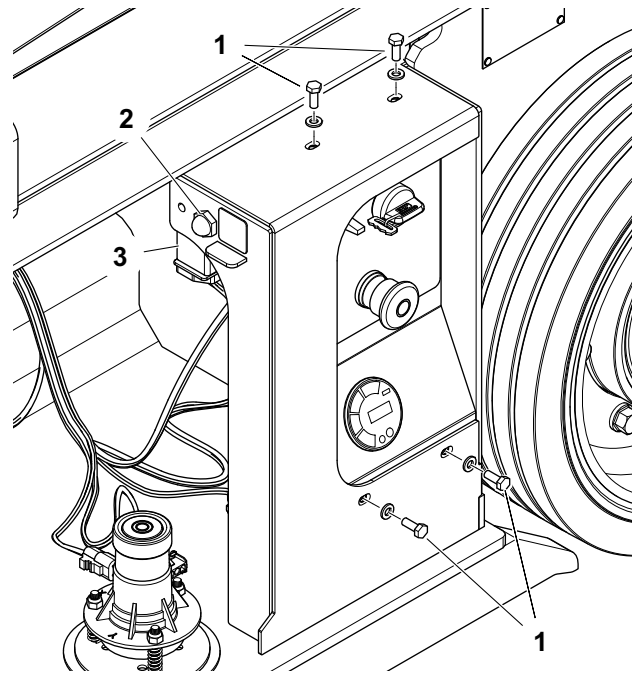

Figure 3-10. Ground Control Station Removal

- | | |
|------------------------------|----------------|
| 1. Attach Screws and Washers | 3. Power Relay |
| 2. Brake Release Switch | |

Installation

1. Check that all components are installed into the panel and connected to the wiring harness.
2. Insert the panel into position on the machine and align the mounting holes in the panel with the mounting holes in the frame.
3. Attach using the (4) mounting screws and washers.
4. Reconnect the main power at the batteries, power machine up and check machine operation.
5. Install machine side cover.

3.7 MAIN POWER CONTACTOR RELAY

The main power relay is located under the rear cover next to the battery charger.

NOTICE

DISCONNECT MAIN POWER FROM THE BATTERIES BEFORE ATTEMPTING TO REMOVE THE MAIN POWER CONTACTOR RELAY OR SERVICING THE ELECTRICAL SYSTEM. FAILURE TO DO SO COULD CAUSE DAMAGE TO THE MACHINES ELECTRICAL COMPONENTS.

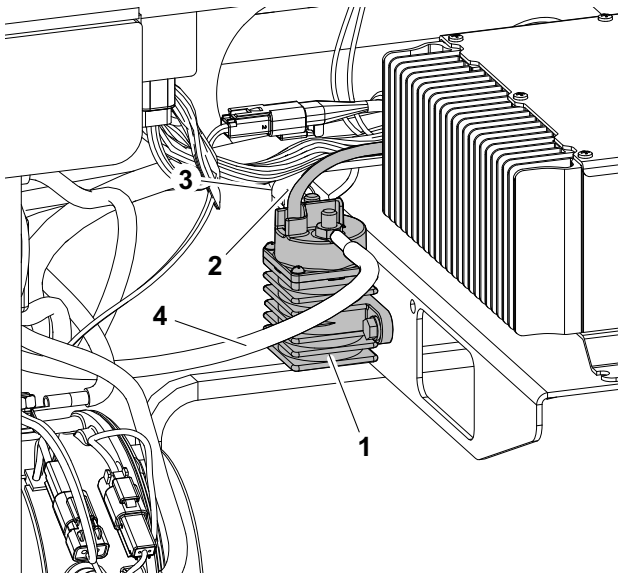
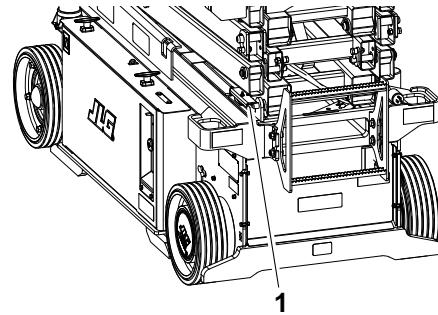

Figure 3-11. Main Power Contactor Relay Location (All Models)

- | | |
|---|-----------------------------------|
| 1. Main Power Contactor Relay | 3. To Battery (BT03+) |
| 2. To X14 Harness Connector -
(Power Relay and Control Module) | 4. To Control Module - (X09 B+F1) |

3.8 ELEVATION LIMIT SWITCH ASSEMBLY

Location



1932RS/6RS

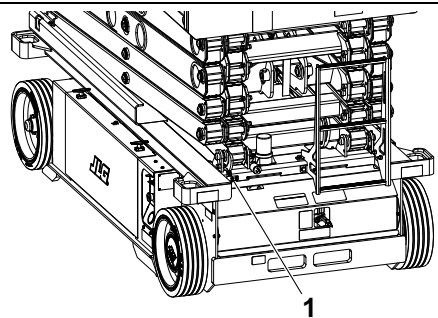

3248RS/10RS

Figure 3-12. Elevation Limit Switch Location

1. Limit Switch

Installation

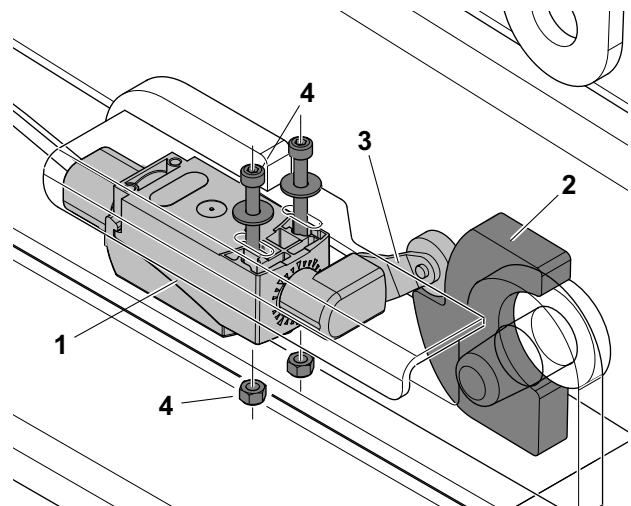

1932RS/6RS

Figure 3-13. Elevation Limit Switch Mounting

- | | |
|--------------------|----------------------|
| 1. Switch Assembly | 3. Switch Lever Arm |
| 2. Scissor Arm Cam | 4. Mounting Hardware |

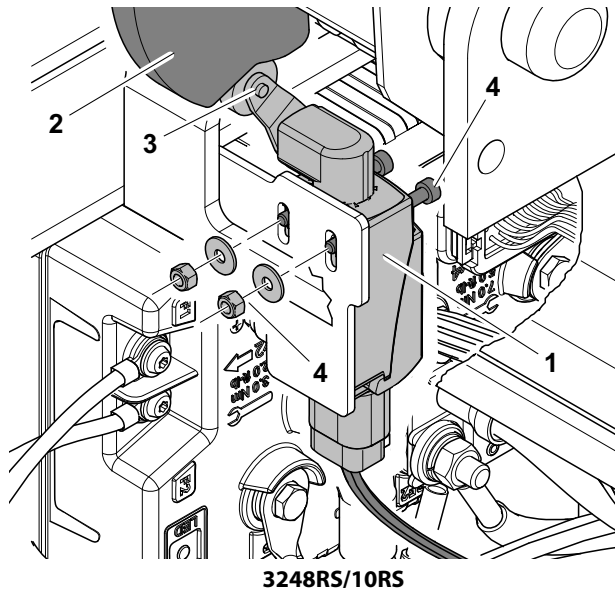

Figure 3-13. Elevation Limit Switch Mounting

- | | |
|--------------------|----------------------|
| 1. Switch Assembly | 3. Switch Lever Arm |
| 2. Scissor Arm Cam | 4. Mounting Hardware |

Switch Adjustment

Models - 1932RS/6RS (See Figure 3-13. and Figure 3-14.)

1. With the roller lever arm set at 30° from vertical, attach switch to frame mount using the mounting hardware as shown.
2. With the scissor arms in the stowed position, adjust the switch fore or aft in the horizontal mounting slots in the frame, so that the roller contacts both surfaces of the scissor arm cam, then tighten.

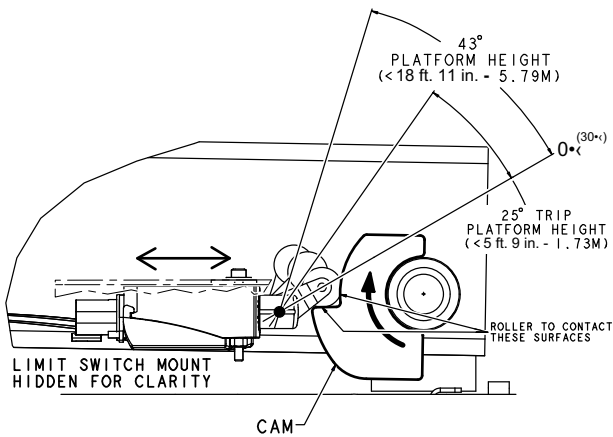

Figure 3-14. 1932RS/6RS - Elevation Limit Switch Adjustment

Models - 3248RS/10RS

(See Figure 3-13. and Figure 3-15.)

1. With the roller lever arm set at 30° from vertical, attach switch to frame mount using the mounting hardware as shown.
2. With the scissor arms in the stowed position, adjust the switch up or down in the vertical mounting slots in the frame, so that the roller contacts both surfaces of the scissor arm cam, then tighten.

Switch Notes (All Models):

- The lever arm angle is to be pre-set to 30° from vertical.
- Switch Reset = 13°
- Switch Trip = 25°
- Drive speed to be reduced before:
1932RS/6RS - 5 ft. 9 in. (1.75 m) platform height
3248RS/10RS - 7 ft. 4 in. (2.25 m) platform height.
- The switch is to be in the trip position (25° - 70°) when the machine platform height is above:
1932RS/6RS - 5 ft. 9 in. (1.75 m) platform height
3248RS/10RS - 7 ft. 4 in. (2.25 m) platform height.
- The switch is to be in the reset position (0° - 13°) when the machine is stowed.

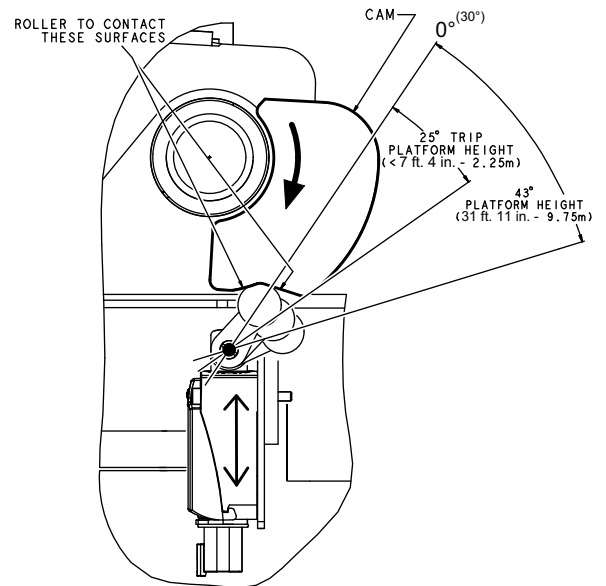

Figure 3-15. 3248RS/10RS - Elevation Limit Switch Adjustment

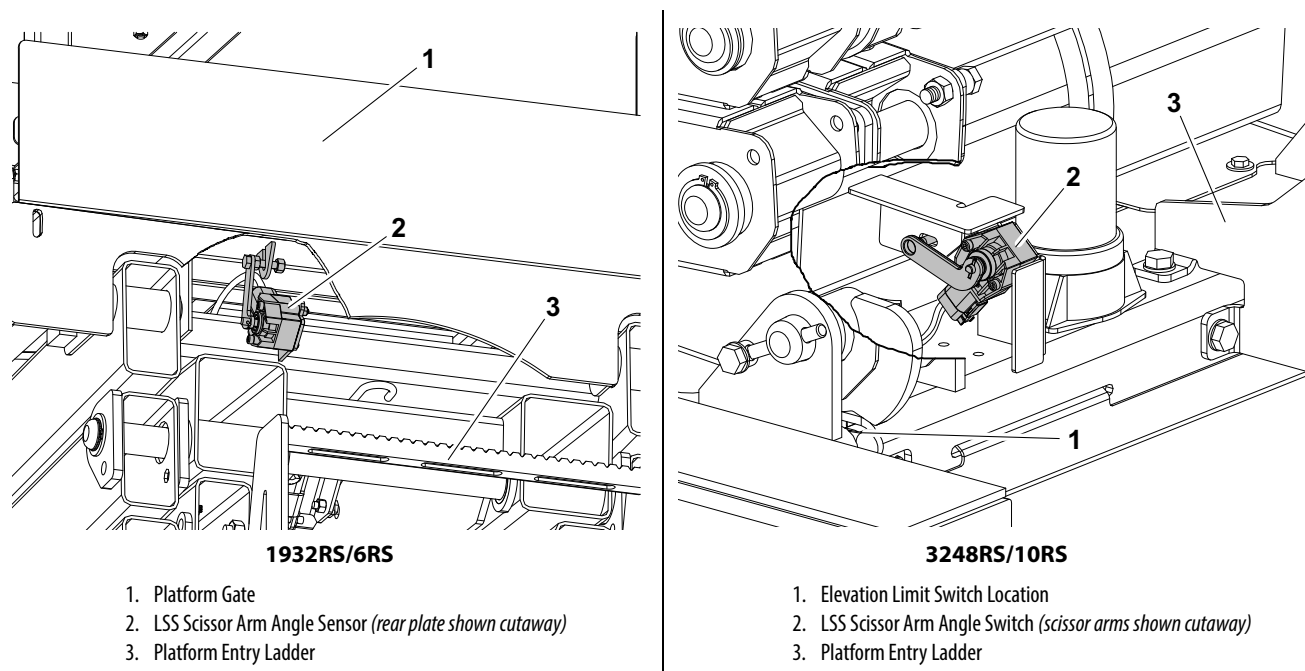

Figure 3-16. LSS - Scissor Arm Angle Sensor - Location Rear of Machine

3.9 LSS - SCISSOR ARM ANGLE SENSOR - LOCATION

RS Scissor machines equipped with the Load Sensing System (LSS) are equipped with a separate scissor arm angle sensor switch besides the standard elevation limit switch. This switch communicates with the power control module in tandem with the lift cylinder pressure switches to accurately determine platform load for any given platform height.

There is no adjustment to the angle sensor switch and arm assembly, just install in the proper orientation.

See the LSS Service Manual (3124288) for complete service information for the RS Scissors - LSS system.

3.10 TILT SENSOR REPLACEMENT

The tilt sensor is located inside the left side machine cover (ground control station side).

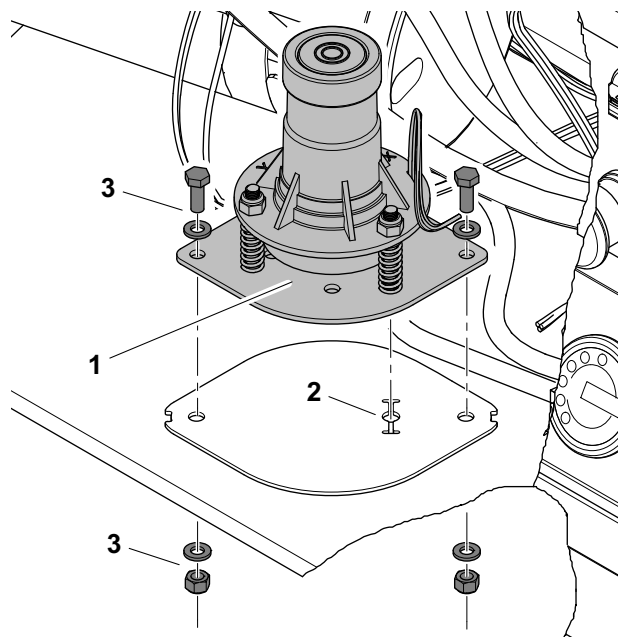

Figure 3-17. Tilt Sensor Installation

- 1. Tilt Sensor
- 2. Locating Hole
- 3. Mounting Hardware

Tilt Sensor Removal

1. Disconnect power at the batteries.
2. Remove the machine left side cover (ground control station side).
3. Unplug the tilt sensor 3-wire harness connector.
4. Remove the two (2) mounting nuts, bolts and washers attaching the sensor to the base frame.

Tilt Sensor Installation

1. Before mounting the tilt sensor to the base frame, check the mating surfaces of the sensor and the mounting plate, be certain there is no debris or burrs to prevent a flush mount.
2. When mounting the tilt sensor back into the base frame, align the mounting pin on the bottom of the sensor with the hole in the mounting plate on the base frame (item 2 - Figure 3-17.).
3. Secure to the base frame with the mounting hardware.
4. Adjust per instructions following.

Tilt Sensor Switch - Adjustment Procedure

NOTICE

PERFORM TILT SWITCH LEVELING PROCEDURE A MINIMUM OF EVERY SIX MONTHS TO ENSURE PROPER OPERATION AND ADJUSTMENT OF SWITCH.

1. Park the machine on a smooth, firm, and level surface. Be sure it is as level as possible.

NOTE: Ensure switch mounting is level and securely attached.

2. Tighten the three flange nuts with a socket wrench. Each nut should be tightened approximately onequarter of its spring's travel.
3. Using bubble level on top of indicator, Tighten or loosen the three flange nuts until indicator is level.
4. Individually push down on one corner at a time. There should be enough travel to cause the indicator to trip. If the indicator does not trip in all three tests, the flange nuts have been tightened too far.

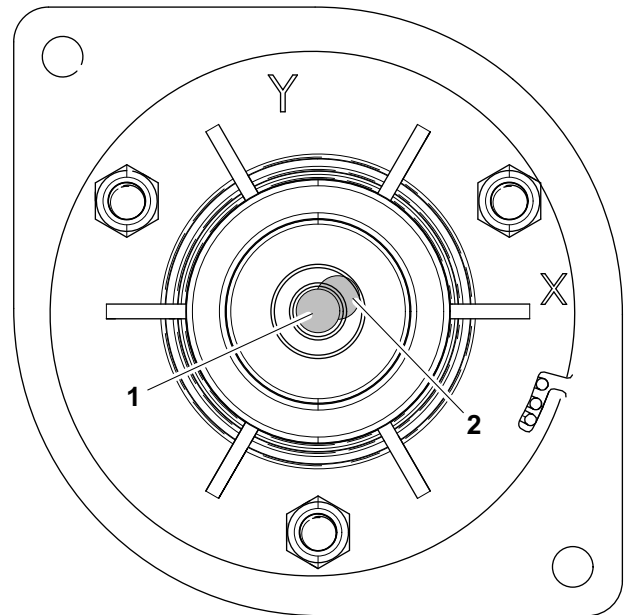

Figure 3-18. Tilt Sensor Switch - Bubble Level

1. Level
2. Not Level

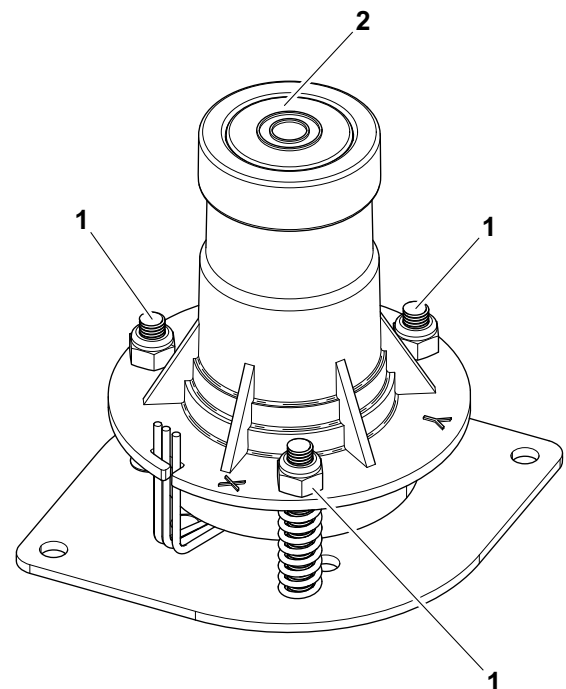

Figure 3-19. Tilt Sensor Switch - Adjustment

1. Flange Adjusting Nuts
2. Bubble Level

3.11 TRACTION SYSTEM

Theory of Operation

The armatures (rotating windings) of the separately-excited drive motors are wired in parallel to the Power Module's -T and +B terminals (ZAPI). The +B Terminal is always at the same voltage as the +B (Battery Voltage when the Line Contactor is closed) and allows the module to measure current with the internal shunt (extremely low impedance). The -T Terminal is pulled to Ground by the Armature Switch MOSFET's (connected to -B Terminal).

To provide variable speed control, the Armature MOSFET transistors switch On and Off at high frequencies (pulse-width modulation; 16kHz). The Duty Cycle (On & Off time) is varied to control the voltage applied to the Armatures. When the MOSFET's spend 50% of the period On and 50% Off, approximately 1/2 of the available Battery Voltage will be applied to the Armatures. Similarly, the MOSFET are On continuously (100% Duty Cycle) to apply all available Battery Voltage to the Armatures (as in Driving at Full Speed).

Instead of permanent magnets, the separately-excited drive motors use electro-magnets (called Field Windings) located in the stator (non-rotating) portion of the motor. Field windings are preferable to permanent magnets because the Power Module can adjust the stator's magnetism for optimum motor performance. When climbing a grade at low speeds, the Power Module may apply as much as 40A to the field windings for more electro-motive force. On level terrain, the Power Module

will apply as little as 14A to the fields for higher rotational speeds and better electrical efficiency.

The Field Windings also provide direction reversal for traction. When driving forward, MOSFET switches 1 and 4 turn On to apply positive potential to F2 and ground potential to F1. In reverse, MOSFET switches 2 and 3 turn On to apply positive potential to F1 and ground potential to F2. These switches are pulse-width modulated by the Power Module to maintain a fixed relationship between Field and Armature Current (also called the Field Map).

Since the two 24V Armatures are wired in parallel, the drive motors will attempt to rotate at the same speed under all conditions. If one wheel slips, the wheel with traction will demand more current as it slows slightly (under load). In this manner, the system provides effective traction control with no added complexity.

It is essential that the same amount of field current is supplied to both drive motors, or one wheel will pull the vehicle (motor overheating and excessive tire wear would result). The vehicle uses 12V field windings wired in series to ensure proper distribution of current.

Two electrically-released parking brakes are mounted to the rear drive motors. The Ground Module energizes the two 24V electro-magnets when appropriate to allow vehicle motion. The parking brakes can be released electrically for emergency vehicle towing.

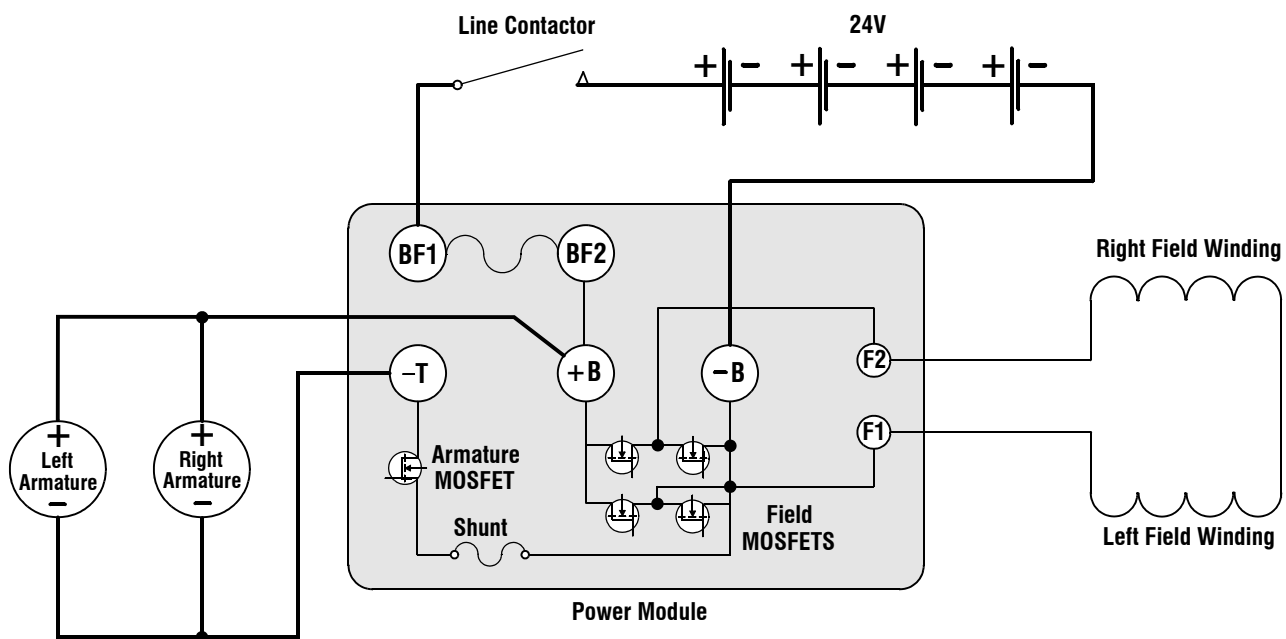

Figure 3-20. Traction Control Circuit - ZAPI Power Module

Common Traction System Difficulties

1. Ground Module Interlocks

There are a variety of interlocks that prevent Drive due to system events. Before investigating Traction System issues, examine the JLG Analyzer's HELP Menu while attempting to Drive from Platform Mode. Refer to the Section 5 for explanation of the JLG Analyzer Help Messages.

2. Power Module Diagnostic Issues

The Power Module executes a self-test during every power-up to ensure proper functionality. If a Diagnostic Issue is detected, the Power Module will not energize the Main Power Contactor. Instead, it will flash the Green LED, please refer to ZAPI Power Module Electrical Evaluation - page 3-18.

3. Open-Circuit Motor Armature

This issue will allow the vehicle to drive, but one motor will handle the entire traction load. Motor overheating and excessive tire wear will result, along with a lack of traction control.

This situation can be detected by elevating the vehicle's front wheels and engaging drive (platform stowed). Under DIAGNOSTICS - TRACTION, the JLG Analyzer's ARM CUR display (Armature Current Reading) should be less than 50A. One wheel will rotate at full speed, while the other will not rotate at all. The Power Module's self-diagnostics cannot detect this fault unless both armatures are open-circuit.

To find the source of the difficulty, disconnect main power at the batteries and investigate the wiring pathways from the Power Controller's M1 and M2 terminals to the armature on the motor that does not rotate. Investigate for issues like improper crimps, loose terminals, and corrosion.

4. Short-Circuit Motor Armature

This issue will allow the vehicle to drive very slowly or not at all. Rapid motor overheating (one motor) will result.

This situation can be detected by elevating the vehicle's front wheels and engaging drive (platform stowed). Under DIAGNOSTICS - TRACTION, the JLG Analyzer's ARM CUR display (Armature Current Reading) will hover around 350A. The FLD CUR display (Field Current Reading) will hover around 40A. Neither wheel will rotate at normal speed, but it will be possible to rotate the drive wheel by hand. The Power Module's self-diagnostics cannot detect this fault since the situation appears identical to climbing a steep grade.

To find the source of the difficulty, disconnect main power at the batteries and disconnect the Armature Wiring (heavy red and black conductors) from the sus-

pected drive motor leading to the Power Module's M1 and M2 Terminals. Re-test the traction function. If the remaining drive motor is able to reach full speed (and Armature Current is less than 50A), the drive motor that has been disconnected is fault. Investigate for crushed and burned cables. Check if the drive motor smells burned.

5. Open-Circuit Motor Field

This issue will allow the vehicle to drive very slowly or not at all. Rapid motor overheating (both motors) will result.

This situation can be detected by elevating the vehicle's front wheels and engaging drive (platform stowed). Under DIAGNOSTICS - TRACTION, the JLG Analyzer's ARM CUR display (Armature Current Reading) will hover around 350A. The FLD CUR display (Field Current Reading) will be erratic or low (less than 10A). Neither wheel will rotate at normal speed, but it will be possible to rotate the drive wheel by hand.

To find the source of the difficulty, pull the Main Battery Disconnect and disconnect the Field Wiring (two blue wires leading to F1 and F2 Terminals) from the Power Module. Using a voltmeter set for resistance scale (Ohms), investigate if there is a short-circuit (less than 5 Ohms) between the two blue wires (this is normal). If not, investigate for improper crimps, burned cables, damaged cables, or damaged field windings.

6. Short-Circuit Brake Release

This issue will not allow the vehicle to drive. Rapid motor overheating (both motors) will result. Continued attempts to drive the vehicle may result in armature damage.

This situation can be detected by elevating the vehicle's front wheels and engaging drive (platform stowed). Under DIAGNOSTICS - TRACTION, the JLG Analyzer's ARM CUR display (Armature Current Reading) will hover around 350A. The FLD CUR display (Field Current Reading) will hover around 40A. Neither wheel will rotate, and it will be impossible to rotate either drive wheel by hand. The Ground Module cannot detect this fault during power-up or self-test since energizing the brakes could pose a hazard. However, it may detect this issue during Drive (investigate using JLG Analyzer).

3.12 POWER CONTROL MODULE - ZAPI

Table 3-3. ZAPI Power Module Specifications

Operating Voltage (B+)	14.5 to 40 VDC
Maximum Current Limits:	
Armature	300 A
Field	40 A
Pump	180 A
Integral Main Fuse	250 A
Standby Current	150 mA
Temperature Range:	
Operating	-40°C to 75°C
Storage	-40°C to 125°C
Thermal Limit	75°C to 90°C
Switching Frequency	16 kHz

The power module is located inside rear machine cover at the left rear of the machine, as shown in Figure 3-21., ZAPI Power Module Location and Orientation (All models). Use the following instructions when replacing the power module.

1. Turn machine power off and disconnect the batteries.
2. Locate and remove the rear cover from the machine.
3. Tag and note the wire terminal locations before removing the power module, also see Figure 3-22.
4. Disconnect all wire connectors and cables from the power module and remove it from the machine.

NOTE: The power module for the RS Scissors is installed on the machine in the upside down position. This is the correct mounting position.

5. When installing the power module, be sure that the terminals are oriented as shown in Figure 3-21.
6. After installing the new power module, begin connecting the wire connectors/cables to the module. (See Table 3-4 and Figure 3-22.)
7. Torque all terminal bolts to torque specifications as shown on the front of the module. Overtightening could damage the module.
8. After all connections to the power module are made, the batteries can be reconnected.
9. Power up machine and check for normal machine operation.
10. Re-install the rear machine cover.

Table 3-4. Module Terminal Functions

+BF1	Controller to Main Power Contactor
+BF2	Left and Right Positive Armature
+B	Positive Pump Connection
-B	Controller to Battery Negative
-T	Left and Right Negative Armature
-P	Negative Pump Connection
F1	To Motor Fields Wired in Series
F2	To Motor Fields Wired in Series

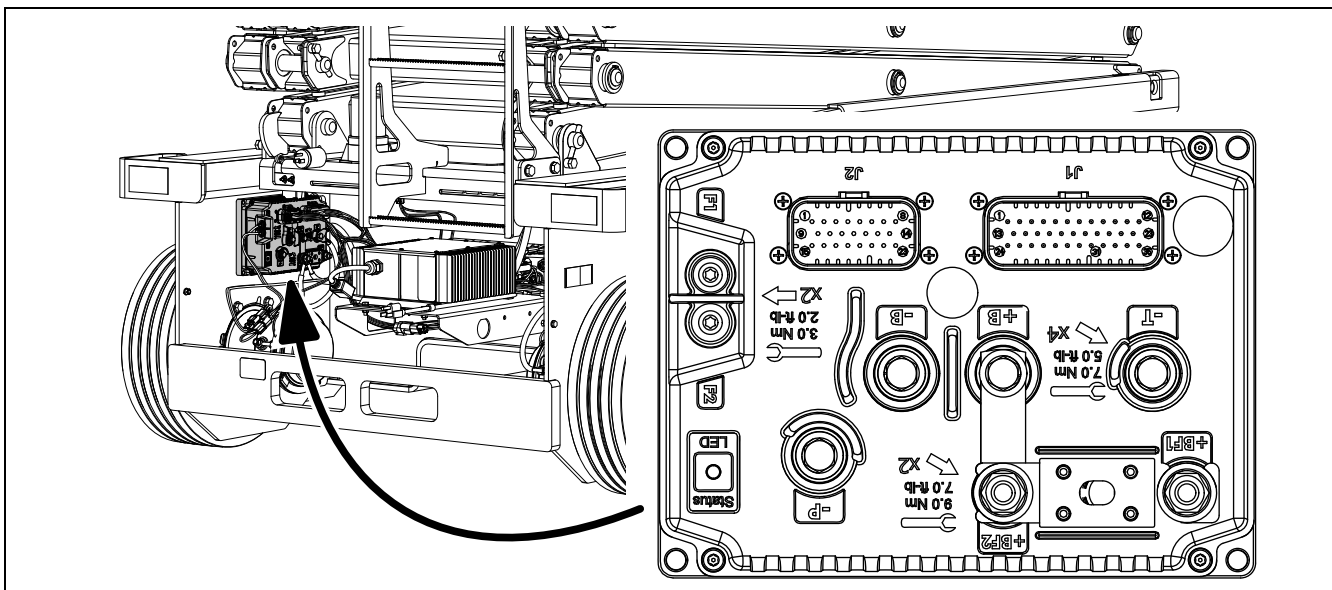

Figure 3-21. ZAPI Power Module Location and Orientation (All models)

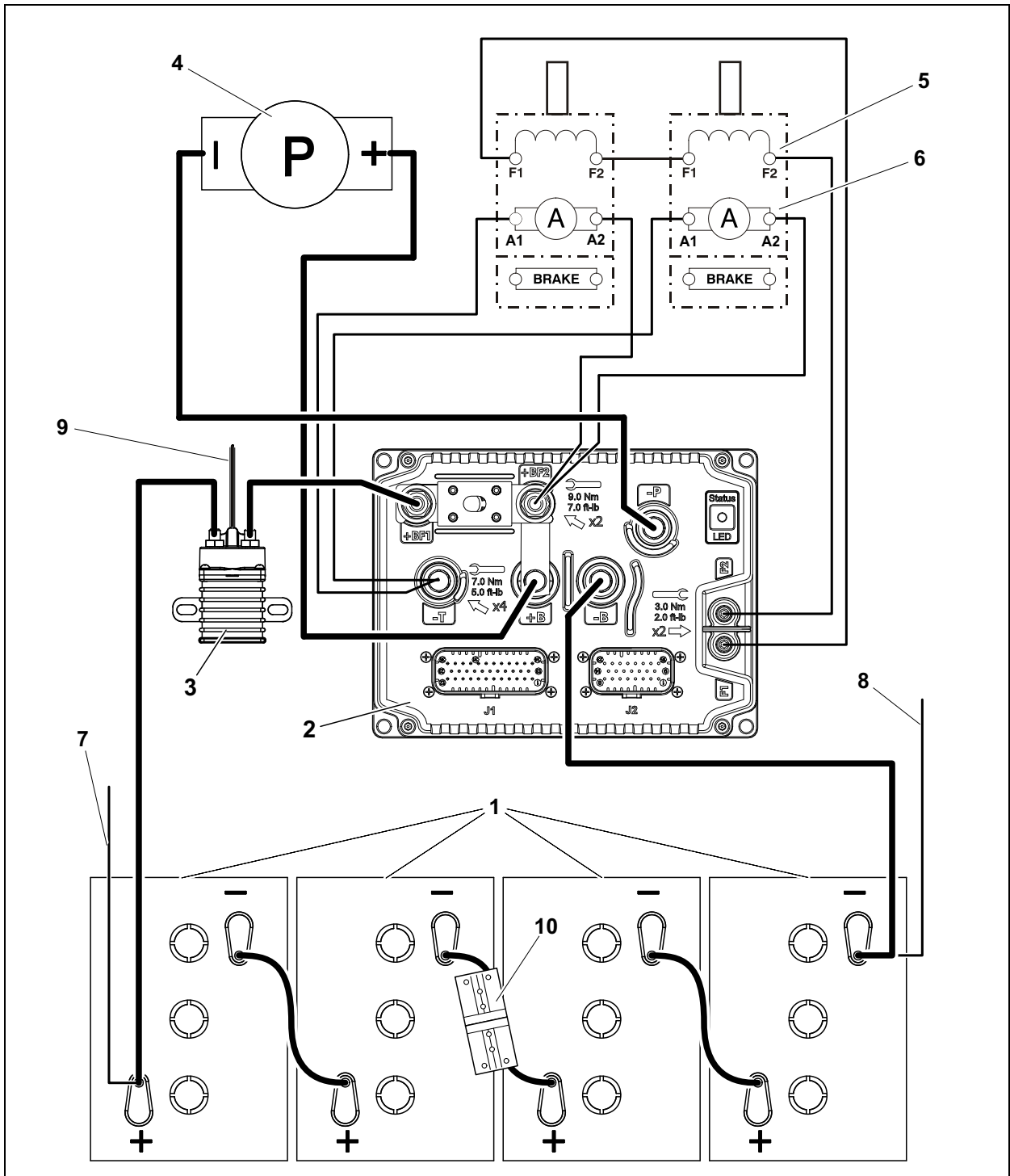

Figure 3-22. Main Electrical Power Connections - (1001129845 - ZAPI Power Module)

- | | |
|-----------------------------------|--|
| 1. Batteries | 6. Drive Motor Armature (Brush) Cables |
| 2. Power Module | 7. To Battery Charger (+) |
| 3. Main Power Contactor Relay | 8. To Battery Charger (-) |
| 4. Hydraulic Pump Motor | 9. To Pin 13 and Pin 32 - J1 Connector on Power Module |
| 5. Drive Motor Stator Field Wires | 10. Battery Quick-Disconnect (OPTION) |

ZAPI Power Module Electrical Evaluation

INTEGRATED HEALTH INDICATOR

The ZAPI Power Module provides a green STATUS LED that shines through the cover to indicate module "health" status. The LED shall be illuminated when the device is powered on. The LED blinks (2Hz) when an internal issue is detected that cannot be repaired by a technician. It should be noted that this will require replacement of the device.

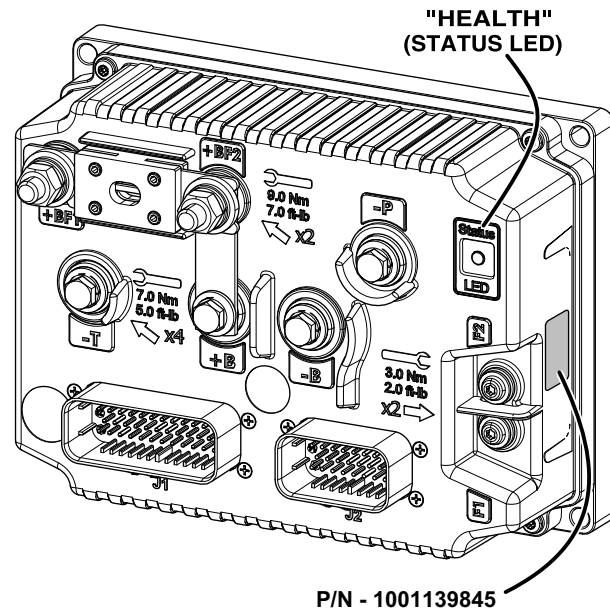

ZAPI Power Module - "HEALTH" (Status LED)

3.13 DRIVE MOTOR SERVICING

The drive motors are located at the rear of the machine, inside the machine rear cover, remove the machine rear cover, see Figure 3-1.

Drive Motor Troubleshooting

1. Turn off power to unit, remove side cover and disconnect main battery power.
2. Disconnect drive motor connections from the Power Module inside rear cover.
3. Verify field continuity between the blue and orange wires. If available, use a 4-wire ohmmeter to verify the field resistance per the applicable motor specification below.
4. Verify armature continuity between the red and black wires. If available, use a 4-wire ohmmeter to verify the field resistance per the applicable motor specification below.

Model	Field Resistance @ 75°F (24°C)	Armature Resistance @ 75°F (24°C)
1932RS/6RS	0.210hms	0.0370hms
3248RS/10RS	0.1270hms	0.0510hms

5. Using a dielectric tester, verify that there are no shorts between the following items:
 - a. Field connector pins and the case of the motor.
 - b. Armature terminals and the case of the motor.
 - c. Field connector pins to the armature terminals.
6. Verify continuity in 2 pin brake connector (yellow and brown wires). Measure the brake resistance and verify that it is between 18 and 22 Ohms.

Drive Motor Electrical Evaluation

Several basic electrical tests can be performed on the Drive Motors. Failure of one of these evaluations is significant and may indicate that the device is physically damaged.

Refer to Figure 7-2., Resistance Measurement. Disconnect the Main Battery Disconnect and all drive motor cables during this analysis.

- **Resistance < 2 Ohms Red to Black Armature Wires.** The heavy red and black conductors are connected to the motor's armature winding. The winding is a very low impedance and should appear to be a short-circuit for an ordinary voltmeter. High resistance can signal corrosion, improper crimps, damaged cabling, worn brushes, a faulty commutator, or an open armature winding.
- **Resistance < 2 Ohms Blue to Orange Field Wires.** The blue and orange conductors are connected to the motor's

field winding. In order to make this measurement, it will be necessary to disconnect the butt-splice on the two orange wires or use a piercing meter probe. As with the armature, the field is a very low impedance and should appear to be a short-circuit for an ordinary voltmeter. High resistance can signal corrosion, improper crimps, damaged connectors, damaged cabling, or an open field winding.

- **Resistance 15-25 Ohms Yellow to Brown Brake Wires.** The yellow and brown wires are connected to the integral brake. Improper resistance can signal corrosion, improper crimps, damaged cabling, or a faulty solenoid.
- **Resistance > 1 Mega-Ohms Red Armature Wire to Motor Housing.** The armature winding should be electrically isolated from the motor housing. Low resistance may be an indication of a crushed cable, a burned cable, or a burned armature winding. Investigate by disconnecting the drive motor cable from the motor and re-measure resistance (isolation).
- **Resistance > 1 Mega-Ohms Blue Field Wire to Motor Housing.** The field winding should also be electrically isolated from the motor housing. Low resistance may be an indication of a crushed cable, a burned cable, or a burned field winding. Investigate by disconnecting the drive motor cable from the motor and re-measure resistance (isolation).
- **Resistance > 1 Mega-Ohms Red Armature Wire to Blue Field Wire.** The armature and field windings should also be electrically isolated from one another. Low resistance may be an indication of a crushed cable, a burned cable, damaged windings. Investigate by disconnecting the drive motor cable from the motor and re-measure resistance (isolation).

Servicing Guidelines

Since the operating environment of industrial equipment varies widely, the following are suggested for periodic maintenance inspection intervals.

- **Normal Service** – Perform routine inspection (outlined in the Inspection and Service portion of this section) every 1,000 hours of drive time.
- **Severe Service** – Perform routine inspection every 500 hours of drive time. Severe service environments are listed below:
 - a. Dusty or dirty locations like cement plants, lumber and flour mills, coal mining, stone quarries, etc.
 - b. High temperature areas like steel mills, foundries, etc.
 - c. Environments with sudden temperature change, such as in refrigeration plant, etc.

Brake - Manual Disengage Procedure

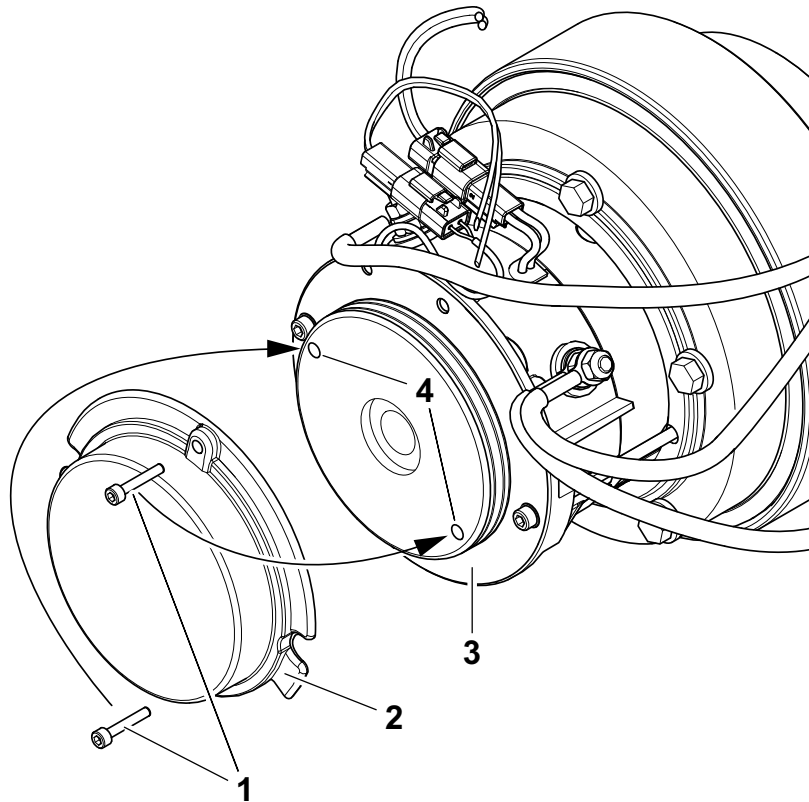

Figure 3-23. Brakes - Manual Disengage Procedure

- | | |
|----------------|--------------------|
| 1. Cover Bolts | 3. Cover Gasket |
| 2. Brake Cover | 4. Disengage Holes |

NOTE: The brakes may also be disengaged electrically using the brake release switch, see procedure in Operation Manual.

⚠ CAUTION

CHOCK WHEELS OR SECURE MACHINE WITH TOW VEHICLE.

1. Ensure battery disconnect switch is in the "OFF" position.
2. Start with either of the drive motors and remove the two cover bolts and brake cover.
3. Thread the cover bolts into the two disengage holes in the brake housing.
4. Tighten down the cover bolts so the brake on that drive motor will disengage.

5. Repeat this procedure on opposite wheel drive. With both drive motor brakes now disengaged, the machine can be moved manually.
6. After towing is complete, chock wheels and remove cover bolts from disengage holes.
7. Reinstall brake cover, replace cover gasket if damaged.

⚠ CAUTION

AFTER THE MACHINE IS TOWED, THE COVER BOLTS MUST BE REMOVED FROM THE BRAKE DISENGAGE HOLES. THE BRAKES CANNOT BE ENGAGED WITH THE DISENGAGE BOLTS IN THE BRAKE DISENGAGE HOLES. THIS WILL CAUSE THE MACHINE TO ROLL WHEN PARKED ON AN INCLINE.

Drive Motor Removal

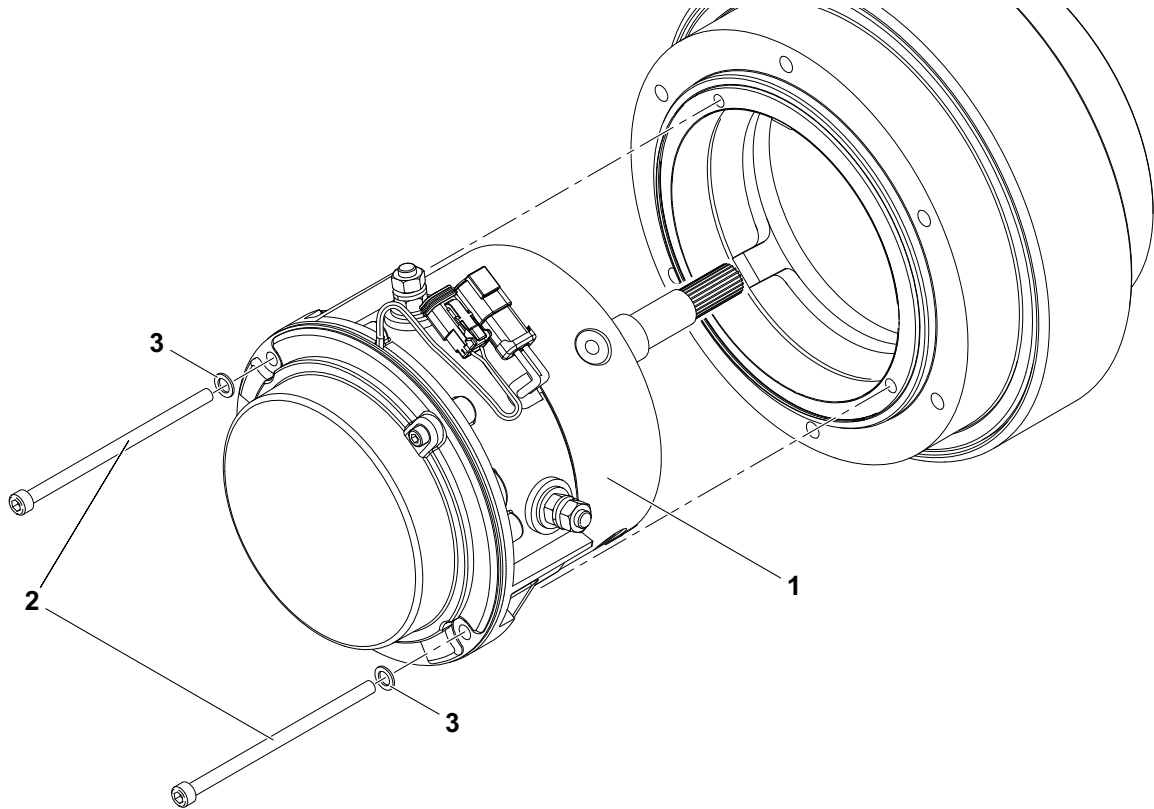

Figure 3-24. Electric Drive Motor Removal

- | | |
|-------------------------|------------|
| 1. Electric Drive Motor | 3. Washers |
| 2. Motor Mounting Bolts | |

NOTICE

DISCONNECT ALL POWER BY REMOVING THE POSITIVE (+) BATTERY CABLE AT THE BATTERIES BEFORE REMOVING DRIVE MOTOR.

1. Disconnect the power cables, brake and field power connectors from the drive motor.
2. Drain the oil out of the unit by removing the cover plug. Note the condition of the oil, replace if necessary.

3. Remove the two motor mounting bolts and washers.
4. Gently remove the drive motor (1).

NOTE: Reference Figure 3-25., Drive Motor Components for part names and locations when servicing the Drive Motor.

Periodic maintenance consisting of inspections of motors, batteries and wiring circuitry is recommended, see Section 2, Table 2-2, Preventive Maintenance & Inspection Schedule..

CAUTION

ALWAYS WEAR EYE PROTECTION DURING ANY MAINTENANCE OPERATION.

Drive Motor Disassembly

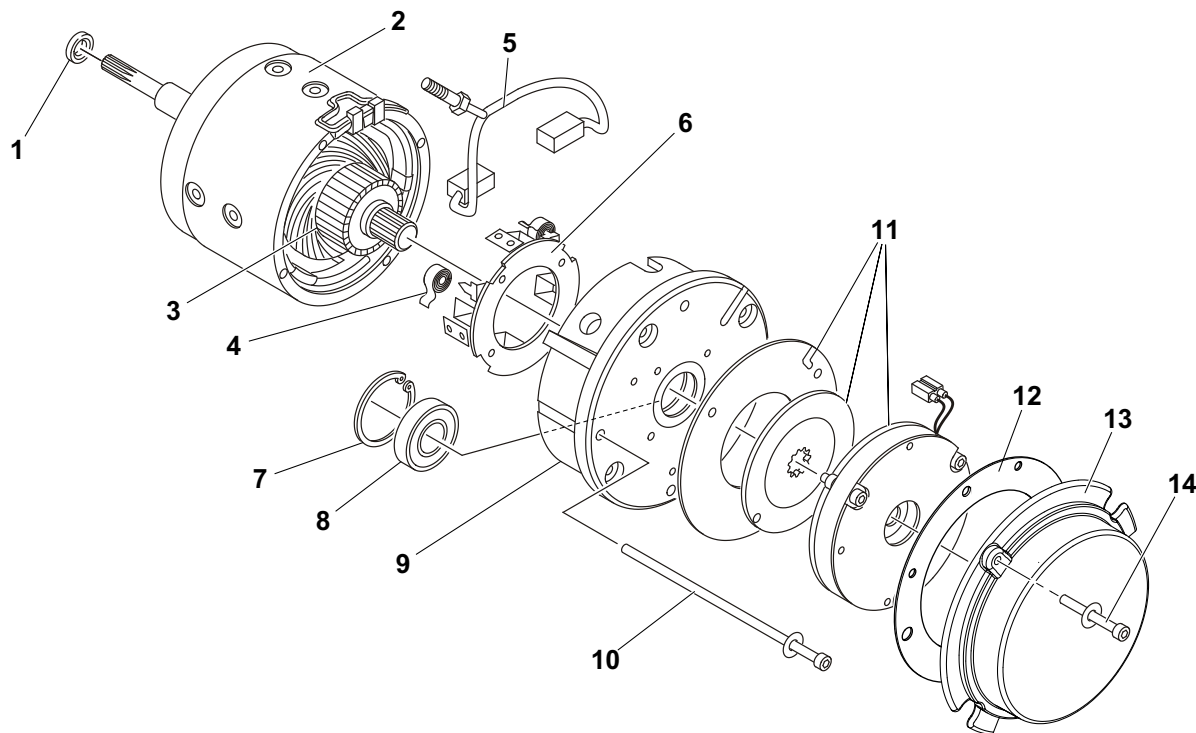

Figure 3-25. Drive Motor Components

- | | |
|---------------------------------------|---|
| 1. Shaft Pilot Bearing | 8. Bearing |
| 2. Frame & Field Assembly | 9. Commutator End Head |
| 3. Armature Assembly | 10. Motor to Hub Mounting Screws (Qty.-2) |
| 4. Brush Spring (4) | 11. Brake Assembly |
| 5. Brush & Terminal Assembly (Qty.-2) | 12. Cover Gasket |
| 6. Brush Box Assembly | 13. Brake Cover |
| 7. Retaining Ring | 14. Brake Cover Mounting Screws (Qty.-2) |

NOTE: Refer to Figure 3-25.

1. Remove the two Cover Plate Mounting Screws (14) holding the Cover Plate (13) in place and remove the cover plate from the motor.
2. Remove the Brake Cover Mounting Screws (15) holding the Brake (11) in place and set aside. These screws are used to manually release the brakes.
3. Remove the two Terminal Cover Mounting Screws (16). Slide the strain relief of the Wire Harness (1) out of the cover and remove the cover from the motor.
4. Discard the Gasket (12) that was located under the brake and terminal covers.
5. Remove the wire harness from the motor by disconnecting the brake connection and armature connections. Cut the field connection close to the crimp connection on the motor side.
6. Install the two Brake Cover Mounting Screws (15) into the threaded holes in the brake assembly and tighten to manually release the brakes (see Figure 3-24.).
7. Remove the three screws holding the brake assembly to the motor. Carefully remove the brake assembly, brake disc and reaction disc from the motor by sliding off of the shaft.

8. Remove the screws holding the Commutator End Head (9) in place and remove the commutator end head from the frame and field assembly. The Armature (2) will be attached to the commutator end head.
9. Pull back the Brush Springs (4) in the commutator end head, pull the brush back and rest the springs on the side of the brush. The brushes should move freely within the holders.
10. Use an arbor press or a bearing puller to remove the armature from the commutator end head assembly.
11. Remove the Snap Ring (7) and Bearing (8) from the commutator end head. Discard the bearing.

Drive Motor Inspection and Service

NOTE: Refer to Figure 3-25.

1. Carefully blow out any accumulated carbon dust and dirt from the Commutator End Head (9) and the Frame & Field Assembly (2) using clean, oil free, compressed air.
 2. Replace Brushes (5) that are worn below their usable length of 0.6 in (1.5 cm), show signs of uneven wear or signs of overheating, such as discolored brush shunts and brush springs. Brushes should always be replaced in complete sets of four. Use identical replacement parts; do not substitute brush grades as the brushes are matched to the motor type and application to provide the best service. Substituting brushes of the wrong grade can cause premature commutator failure and excessive brush wear.
 3. Make sure the Brush Box Assembly (6) is tight on the commutator end head. Replace brush box assemblies in the commutator end head if they are physically damaged or brush holders are loose on the brush plate.
 4. Visually inspect the frame and field assembly for overheating or other signs of damage. Check all wiring to ensure that the insulation is in good condition. Verify that pole screws are torqued to 250 - 300 in-lb (28.2 - 33.9 Nm). Verify field resistance using a suitable ohmmeter per the appropriate motor specification. Verify that the field is electrically isolated from the frame using a dielectric tester. Replace as necessary.
 5. Visually inspect the Armature Assembly (3) for signs of overheating or physical damage. Visually inspect the seal surface of the shaft for excessive wear. Check for grounded circuits using a dielectric tester by applying voltage between the commutator and the shaft. Visually inspect the commutator for excessive wear and overheating. Replace as necessary.
 6. Visually inspect the brake surfaces for excessive wear. Replace Brake Assembly (11) if necessary.
7. Visually inspect the Wire Harness (1) for frayed insulation, loose terminals, or other damage. Replace as necessary.

Drive Motor Reassembly

NOTE: Refer to Figure 3-25.

1. After inspection and servicing, reassemble the wiring in the Commutator End Head (9) as originally found. Ensure the wiring does not contact metal parts and that it allows the brushes to move unrestricted in the holders. Motor terminals must be assembled as shown Figure 3-27. Torque bottom terminal nut to 110 - 140 in-lb (12.4 - 15.8 Nm).
2. After the motor has been disassembled, it is recommended that new bearings be installed because bearings may have been damaged during removal. Although the bearings may appear and feel good, the bearing races could be "brinelled" (races or balls deformed) and may exhibit noise and vibration problems or fail within a relatively short period of service. Press a new bearing into the commutator end head, pressing on the outer race only. See Figure 3-26.. Replace the Retaining Ring (7) in the retaining ring groove.
3. Press the Armature (3) commutator end into the commutator end head and bearing assembly, carefully supporting the inner-race of the bearing. See Figure 3-26.
4. Carefully release the Brush Springs (4) allowing the Brushes (5) to contact the commutator. Make sure brush shunts do not interfere with spring movement.
5. Assemble the commutator end head to the Frame & Field Assembly (2) and tighten the screws to 120 - 140 in-lb (13.6 - 15.8 Nm). Make sure to align the field connection with the notch in the commutator end head. Seal wires where they exit from commutator end head with the Grommet (10).
6. Place the Gasket Seal (12) in the bottom of the notch in the commutator end head. Align wires from the Brake Assembly (11) into the notch in the commutator end head. Secure brake assembly to commutator end head using three bolts.
7. Install Wire Harness (1) to motor by connecting the brake connectors and securing the armature terminals to the terminal studs. Crimp the field connection (red/orange to orange and blue to blue) together and heat shrink. Motor terminals must be assembled as shown in **Always secure the bottom nut with a wrench as you tighten the top nut.** Torque top nut to 90 - 110 in-lb (10.2 - 12.4 Nm).

SECTION 3 - CHASSIS & SCISSOR ARMS

8. Remove manual release screws from brake assembly. Apply new Gasket (12) and affix brake cover to motor using the 2 manual release screws.
9. Attach terminal cover to the commutator end head using two terminal cover screws.
10. Slide the strain relief of the wire harness into the slot of the terminal cover. Align cover plate with groove in frame and field and affix using two cover plate screws.

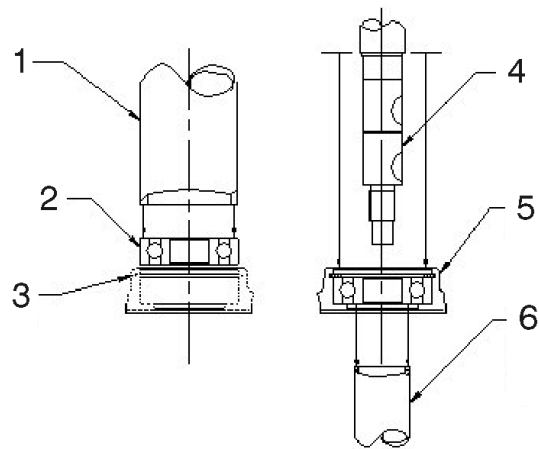

Figure 3-26. Drive Motor Shaft Bearing

1. Press Fixture must press against Outer Race
2. Bearing
3. End Head (held stationary)
4. Armature Assembly
5. Assembled End Head, Bearing, and Retaining Ring
6. Press Fixture must press against Inner Race (held stationary)

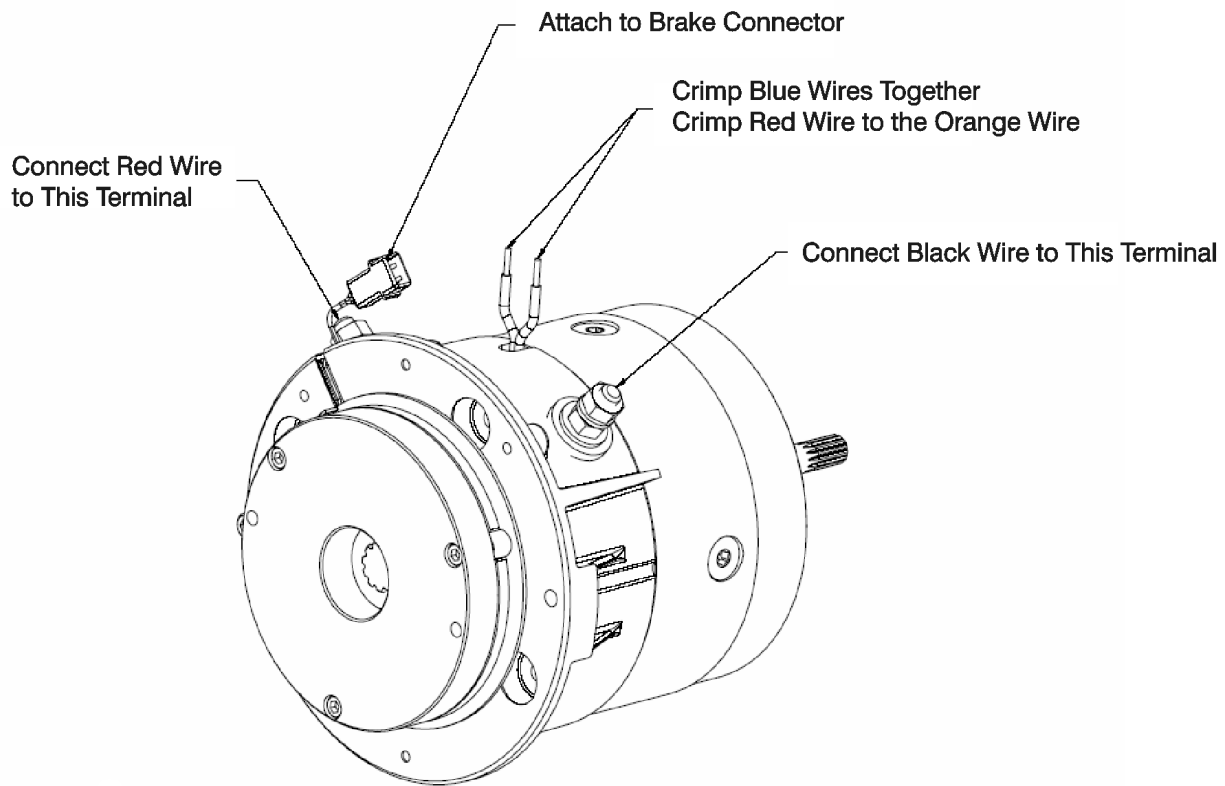

Figure 3-27. Wire Harness Connections

Drive Motor Installation

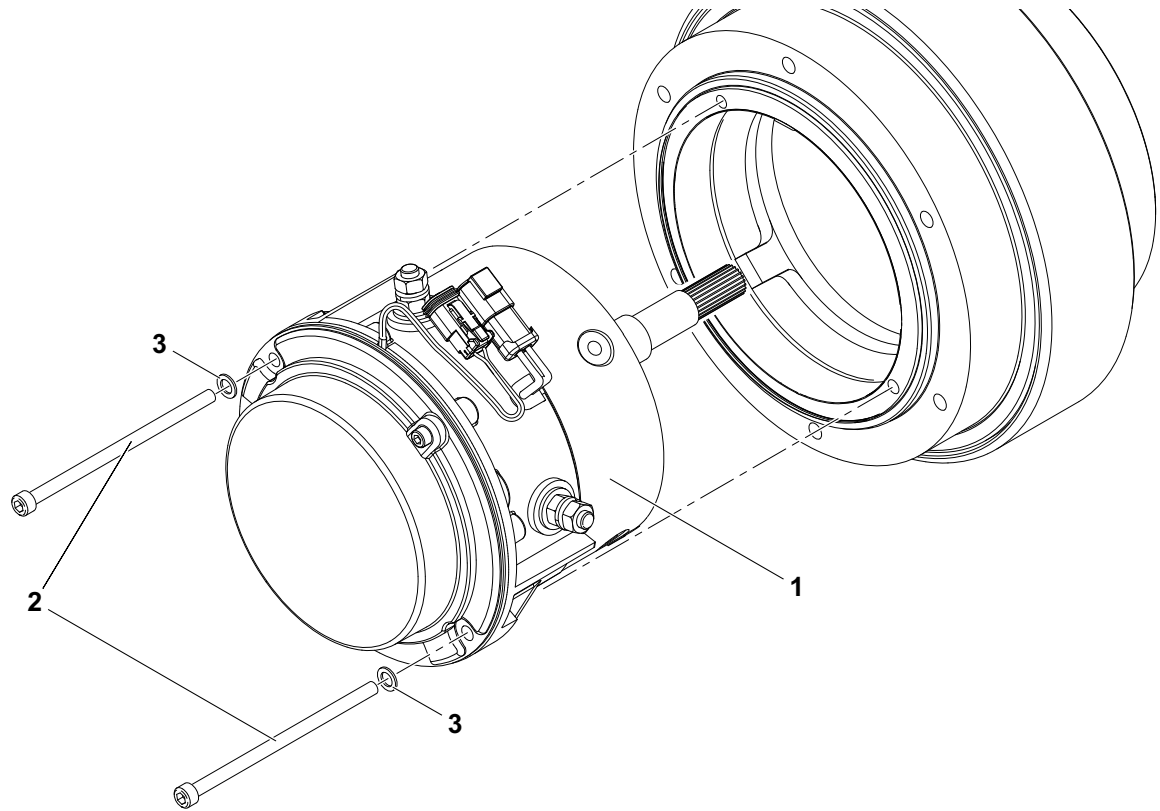

Figure 3-28. Drive Motor Assembly

- | | |
|-------------------------|------------|
| 1. Drive Motor | 3. Washers |
| 2. Motor Mounting Bolts | |

1. Insert the drive motor into the back of the gearbox. The drive motor will pilot on the four bosses in the gearbox. Try to keep the end of the motor shaft from causing damage to the lip seal in the gearbox.

NOTE: *The motor may need to be rotated to line up the sun gear splines with the motor shaft splines.*

2. Install the two motor mounting bolts and washers. Torque to 9 - 11 ft-lbs (12 - 15 Nm).
3. Connect the end of the Motor Cable to the Power Module.
4. Fill the gearbox with oil ISO grade 68 oil or oil of a similar viscosity (80W gear oil or 20W engine oil). The gearbox will need to be filled with 10 oz of oil.

3.14 TORQUE HUB SERVICING

NOTICE

THE PROCEDURES WITHIN THIS SECTION APPLY TO ALL MACHINES AND TORQUE HUBS. PROCEDURES THAT APPLY TO SPECIFIC MACHINES AND TORQUE HUBS WILL BE SO NOTED BY PROPER SERIAL NUMBERS.

NOTE: *These instructions will cover how to completely assemble and disassemble the Torque-Hub unit. However, if the unit is under warranty you should contact JLG Industries, Inc. for a replacement unit. The warranty will no longer be valid if the unit is disassembled by non-JLG personnel.*

NOTICE

TORQUE HUB UNITS SHOULD ALWAYS BE ROLL AND LEAK TESTED BEFORE DIS-ASSEMBLY AND AFTER ASSEMBLY TO MAKE SURE THAT THE UNIT'S GEARS AND SEALANTS ARE WORKING PROPERLY.

Torque-Hub units should always be roll and leak tested before disassembly and after assembly to make sure that the unit's gears, bearings and seals are working properly. The following information briefly outlines what to look for when performing these tests.

⚠ WARNING

IF THE MACHINE IS ON ANY INCLINE, THE WHEELS MUST BE ADEQUATELY BLOCKED PRIOR TO MANUALLY DISENGAGING THE BRAKES. FAILURE TO DO SO MAY RESULT IN INJURY OR EVEN DEATH.

NOTE: *The brake must be released before performing the roll test. This can be accomplished by connecting the brake release cable and depressing button. The brake can also be released by following the manual disengage procedures outlined in this section.*

⚠ CAUTION

RE-ENGAGE BRAKES BEFORE RETURNING TO NORMAL OPERATION.

Roll Test

The purpose of the roll test is to determine if the unit's gears are rotating freely and properly. You should be able to rotate the wheel or hub of the gearbox by hand. If you feel more drag in the gears only at certain points, then the gears are not rolling freely and should be examined for improper installation or defects. Some gear packages roll with more difficulty than others. Do not be concerned if the gears in your unit seem to roll hard as long as they roll with consistency.

Leak Test

The purpose of a leak test is to make sure the unit is air tight. You can tell if your unit has a leak if the pressure gauge reading on your leak checking fitting starts to fall after the unit has been pressurized and allowed to equalize. Leaks will most likely occur at the pipe plugs, the main seal or wherever o-rings are located. The exact location of a leak can usually be detected by brushing a soap and water solution around the main seal and where the o-rings or gaskets meet on the exterior of the unit, then checking for air bubbles. If a leak is detected in a seal, o-ring or gasket, the part must be replaced, and the unit rechecked. Leak test at **10 psi** for 20 minutes.

NOTE: *Due to the small air volume inside this Torque-Hub, it will pressurize to 10 psi very quickly. If the pressure becomes excessive in the unit the seals will be destroyed.*

Oil Check/Fill Procedure

The torque hub unit is shipped with ISO 68 viscosity oil (hydraulic fluid). It is designed to utilize the same oil throughout its service life. However, should it need to be checked/serviced use the following procedure.

In the event of servicing, fill the unit with ISO grade 68 hydraulic oil.

NOTE: *The gearbox capacity is 10 oz of oil.*

1. To check the oil level, rotate the wheel so that the plugs in the cover are at 12 o'clock and 3 o'clock.
2. Allow the oil to settle then slowly remove the plug at 3 o'clock.
3. If oil begins to come out the oil level is sufficient.
4. If no oil is noticed at the 3 o'clock plug remove both plugs.
5. Slowly add oil at the 12 o'clock plug location until oil begins to seep out at the 3 o'clock plug location.
6. Apply pipe dope or teflon tape to the cover plugs and reinstall into the cover.
7. Tighten to 6 ft lbs - 8 ft lbs (8.4 Nm to 11.2 Nm).

Main Gearbox Disassembly

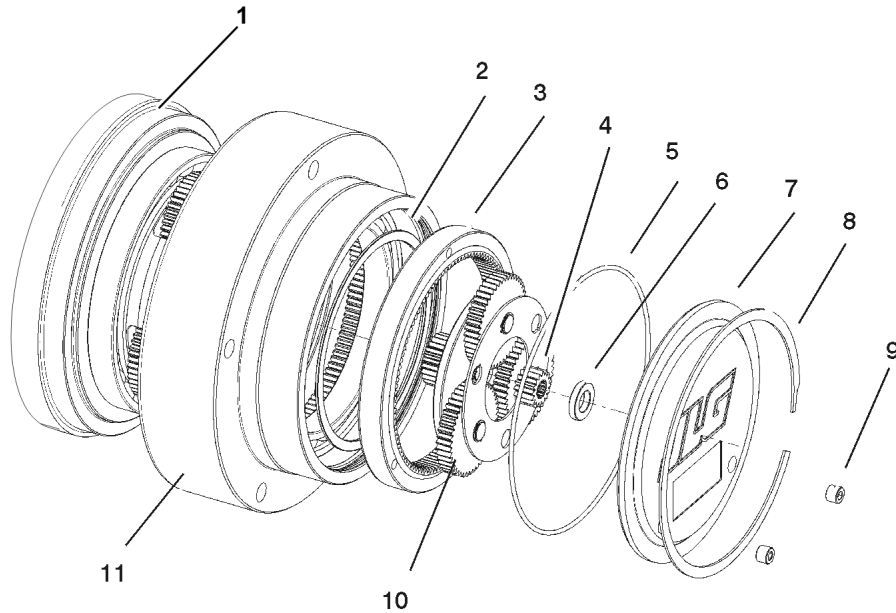

Figure 3-29. Main Gearbox Disassembly

- | | |
|-------------------------|--------------------------------|
| 1. Spindle Sub-Assembly | 7. Cover |
| 2. Spiral Snap Ring | 8. Cover Snap Ring |
| 3. Input ring Gear | 9. Pipe Plug |
| 4. Input Sun Gear | 10. Input Carrier Sub-Assembly |
| 5. Cover O-Ring | 11. Hub Sub-Assembly |
| 6. Cover Thrust Washer | |

1. Using a screwdriver, pry off the cover snap ring.
2. Remove cover. Cover Thrust washer should be in the inner counter bore of the cover.

NOTE: To grip the cover for removal a pipe may need to be inserted into the pipe plug holes.

3. Remove input sun gear.
4. Remove input carrier sub-assembly.
5. Remove cover o-ring.
6. Remove input ring gear.

NOTE: The input ring gear is held in with a press fit on its outside diameter. Insert jacking screws (1/4-20UNC grade 8) with at least 1.5 inches of thread length into each of the three tapped holes to force the ring gear out. Be sure and alternate between the jacking screws to keep the ring gear from becoming misaligned in the bore. The screws will push against the outer race of the main bearing. This bearing will have to be replaced afterwards.

7. Using a screwdriver remove spiral snap ring.
8. Pull hub sub-assembly off of the spindle sub-assembly.

Input Carrier Disassembly

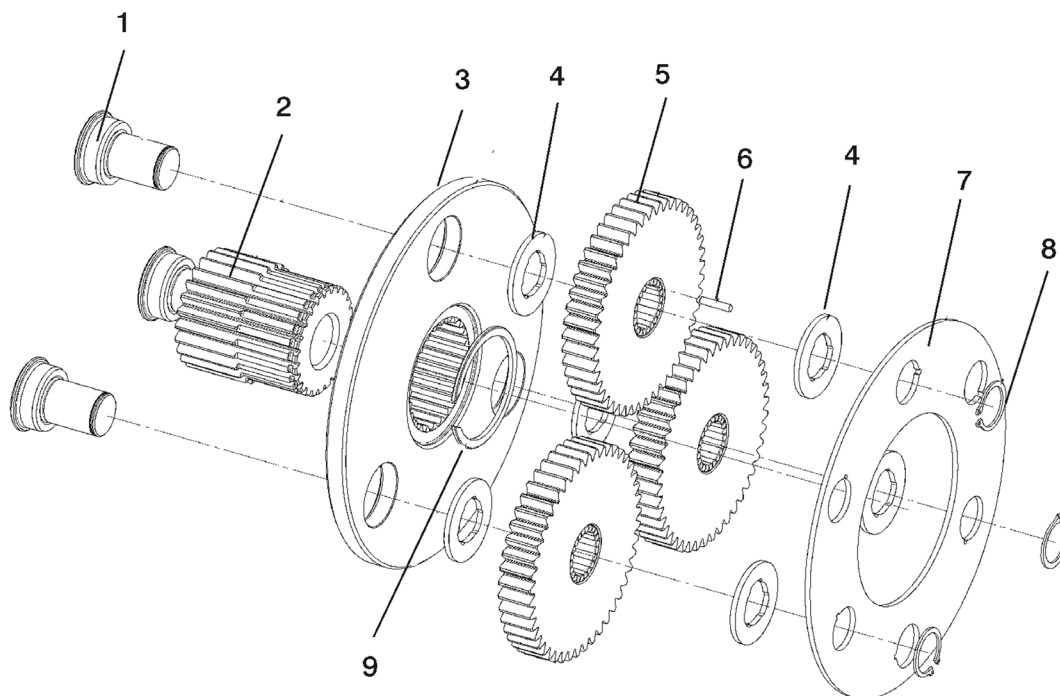

Figure 3-30. Input Carrier Disassembly

- | | |
|----------------------|--------------------|
| 1. Planet Gears | 6. Needle Bearings |
| 2. Output Sun Gears | 7. Thrust Plate |
| 3. Input Carrier | 8. Snap Ring |
| 4. Thrust washer | 9. Retaining Ring |
| 5. Input Planet Gear | |

1. Remove retaining rings from each of the 3 planet shafts.
NOTE: Do not overstress these retaining rings when removing them.

NOTE: The planet pins are held in with a press fit. To avoid damage to the parts, use an arbor or hydraulic press to remove the planet pins.

2. Remove thrust plate.
3. Remove a thrust washer from each planet shaft.
4. Slide each input planet gear off the planet shaft.
5. Remove 22 needle bearings from the bore of each planet gear.
6. Remove the thrust washer from each planet gear.
7. Remove retaining ring from output sun gear.
8. Slide output sun gear out from the center of the input carrier.
9. Remove the three planet shafts from the input carrier.

Hub Disassembly

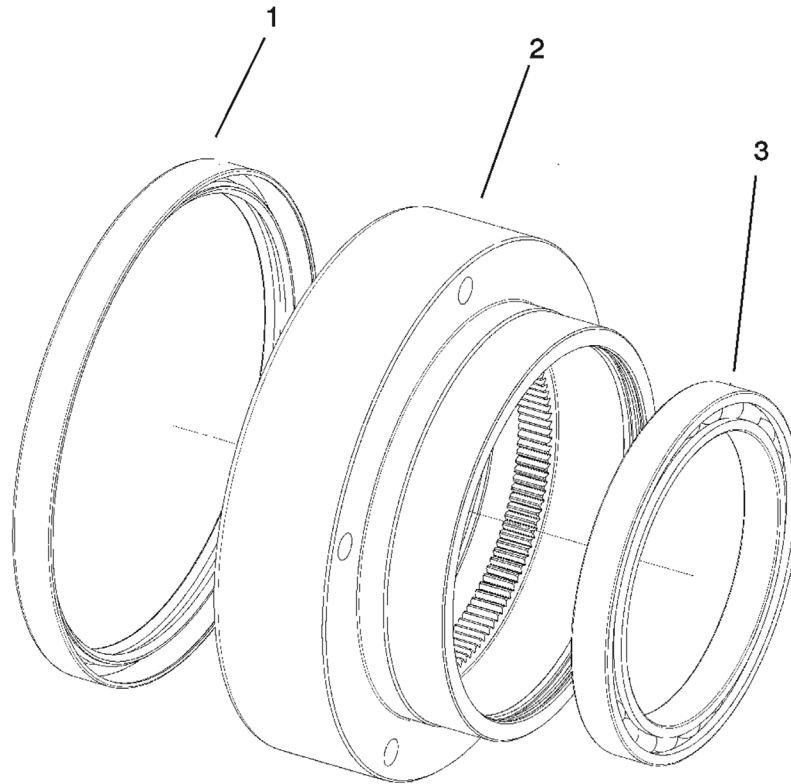

Figure 3-31. Hub Disassembly

- | | |
|---------|-----------------|
| 1. Seal | 3. Main Bearing |
| 2. Hub | |

1. Remove main wheel bearing.

NOTE: This part is held in the hub with a press. To remove have the hub sitting seal side up. Use a plate or rod with a large enough diameter push in the inner race of the bearing. Apply force to the push the bearing out. This bearing will need to be replaced upon reassembly.

2. Remove main lip seal.

NOTE: This lip seal is also held in with a press fit. Remove the lip seal only if the hub or seal needs to be replaced. The lip seal will most likely become damaged during removal. Try not to damage the hub bore.

Spindle Disassembly

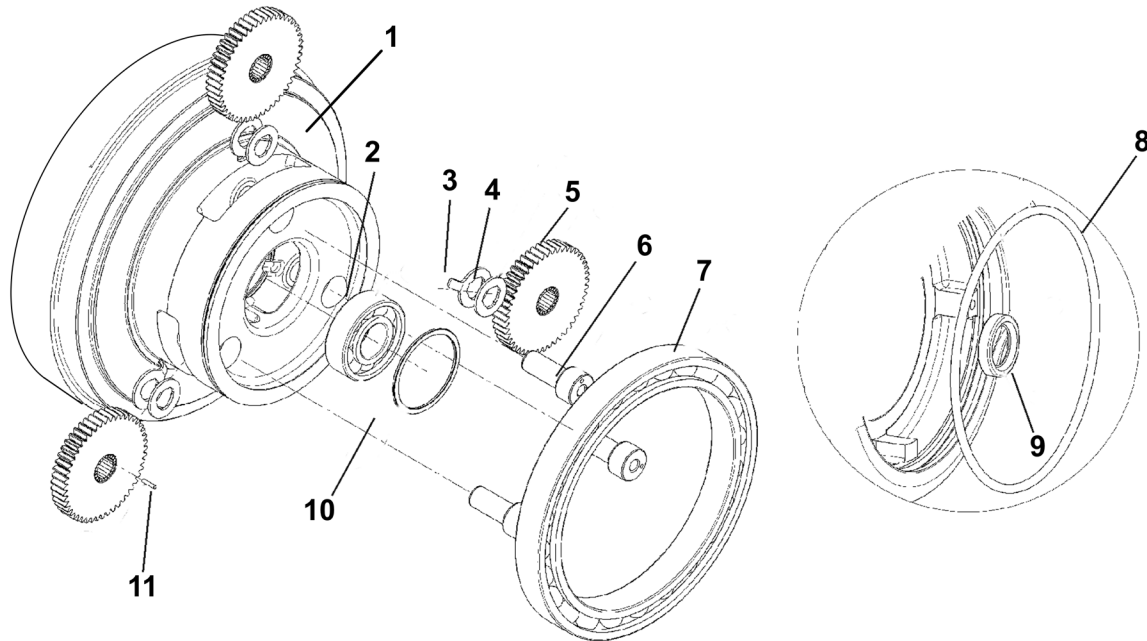

Figure 3-32. Spindle Disassembly

- | | |
|-------------------------|----------------------------|
| 1. Spindle Sub-Assembly | 7. Main Bearing |
| 2. Shaft Ball Bearing | 8. O-Ring |
| 3. Tanged Washer | 9. Shaft Seal |
| 4. Thrust Washer | 10. Snap Ring |
| 5. Output Planet Gear | 11. Needle Roller Bearings |
| 6. Output Planet Pins | |

1. Place unit on bench with planet gears facing up.
2. Remove 3 output planet shafts.

NOTE: These planet shafts are held in with a press fit. Use the tapped hole in the end of the pin in conjunction with a slide hammer or similar tool to remove them.

3. Remove the output planet gear, thrust washer, and tapered washer out of each gear "window" of the spindle.

NOTE: The output planet gears are a very similar size to the input planet gears, tag or label the planet gears to avoid confusion.

4. Using a screwdriver remove the shaft bearing snap ring.
5. Remove the shaft ball bearing from the center bore.

6. Press out the motor shaft seal from the center bore.

7. Remove the main bearing from the outside diameter of the spindle.

NOTE: This bearing is held in with a press fit. You will need to pry against the spindle to remove it. The bearing will need to be replaced when this is done.

8. Remove the motor o-ring from the groove on side opposite from the carrier side.

Tightening and Torquing Bolts

If an air impact wrench is used to tighten bolts, extreme care should be taken to ensure that the bolts are not tightened beyond their specified torque.

The following steps describe how to tighten and torque bolts or socket head cap screws in a bolt circle.

1. Tighten (but do not torque) bolt "A" until snug.
2. Go to the opposite side of the bolt circle and tighten bolt "B" until equally snug.
3. Crisscross around the bolt circle and tighten remaining bolts.
4. Now use a torque wrench to apply the specified torque to bolt "A".
5. Using the same sequence, crisscross around the bolt circle and apply an equal torque to the remaining bolts.

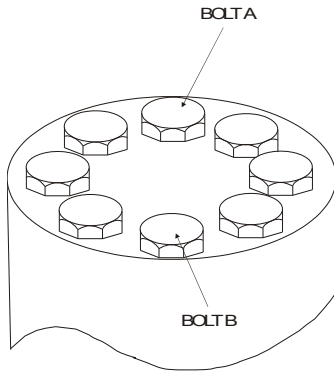

Assembly Tools

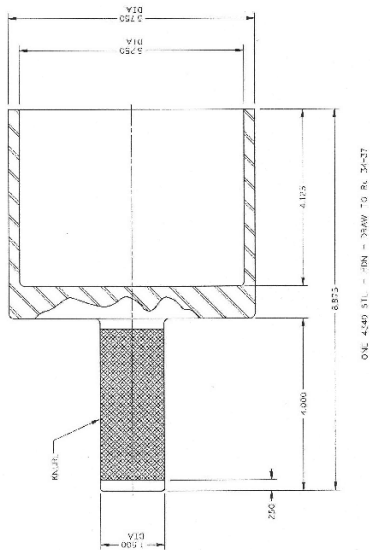

Figure 3-33. Assembly Tool 1

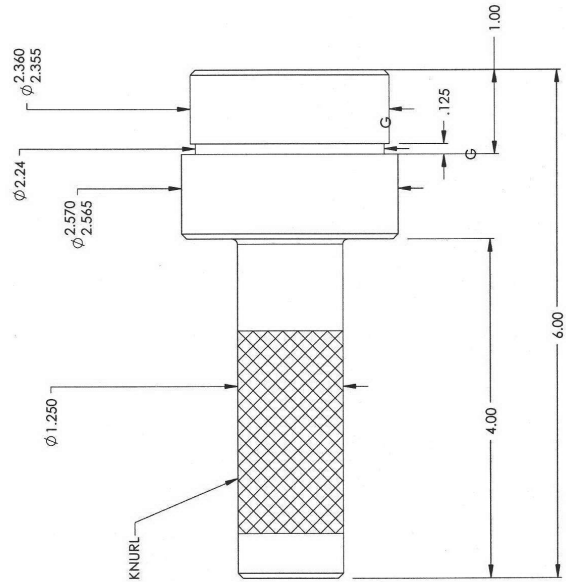

Figure 3-34. Assembly Tool 2

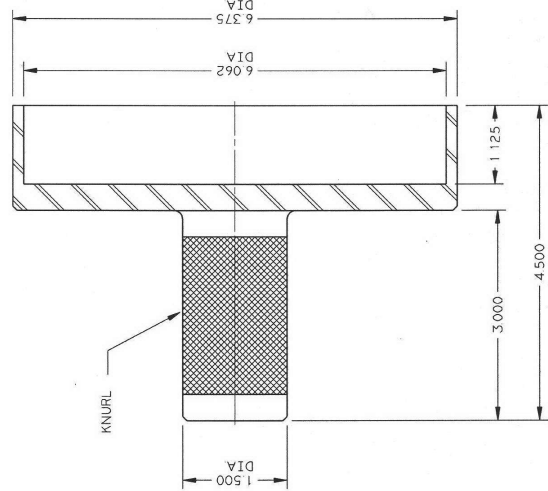

Figure 3-35. Assembly Tool 3

Spindle Assembly

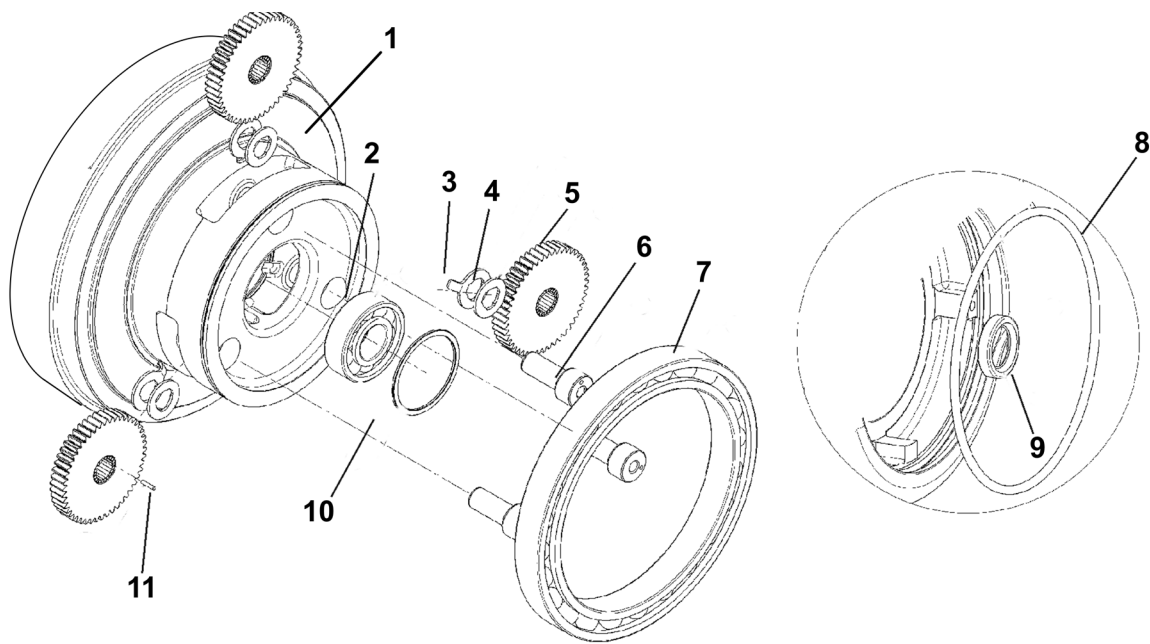

Figure 3-36. Spindle Assembly

- | | | |
|-------------------------|-----------------------|----------------------------|
| 1. Spindle Sub-Assembly | 5. Output Planet Gear | 9. Shaft Seal |
| 2. Shaft Ball Bearing | 6. Output Planet Pins | 10. Snap Ring |
| 3. Tanged Washer | 7. Main Bearing | 11. Needle Roller Bearings |
| 4. Thrust Washer | 8. O-Ring | |

1. Using the appropriate pressing tool, press on main bearing until it is fully seated.
2. Insert the motor shaft bearing into the center bore of the spindle. The bearing is a slight slip fit, but it may require some press to assemble if the bearing becomes misaligned.
3. Retain the bearing with the spiral retaining ring.
4. Line the bore of the output planet gear with 22 needle rollers. Use grease to retain the needle rollers in the bore.
5. Place tanged thrust washer into each planet "window" of the spindle. Make sure the tang sits in the cast groove on the inside of the window.
6. Place a thrust washer onto the planet gear. Line up the bores as best as you can. Use grease to hold the thrust washer in place.
7. Slide the planet gear into the window with the tanged washer until the bores line up.
8. Insert an output planet pin into the planet pin hole of the spindle and through the bores of the thrust washers and the planet gear.
9. Before pressing the planet pin into the spindle make sure the gear spins freely.
10. Press the planet pin into the spindle until it bottoms out. Make sure the planet gear turns freely after the planet pin is pressed in.
11. Repeat Steps 6-12 for the other two output planet gears.
12. Turn the spindle over so that the carrier is down.
13. Using a flat plate or rod, press the motor shaft seal into the center bore so that it is flush with the face of the spindle.
14. Grease and install the motor o-ring into the groove.

⚠ WARNING

CARE SHOULD BE TAKEN TO PREVENT ANY OIL FROM MAKING CONTACT WITH THE BRAKE DISCS. IF THIS OCCURS IT WILL DEGRADE THE BRAKES PERFORMANCE.

Hub Assembly

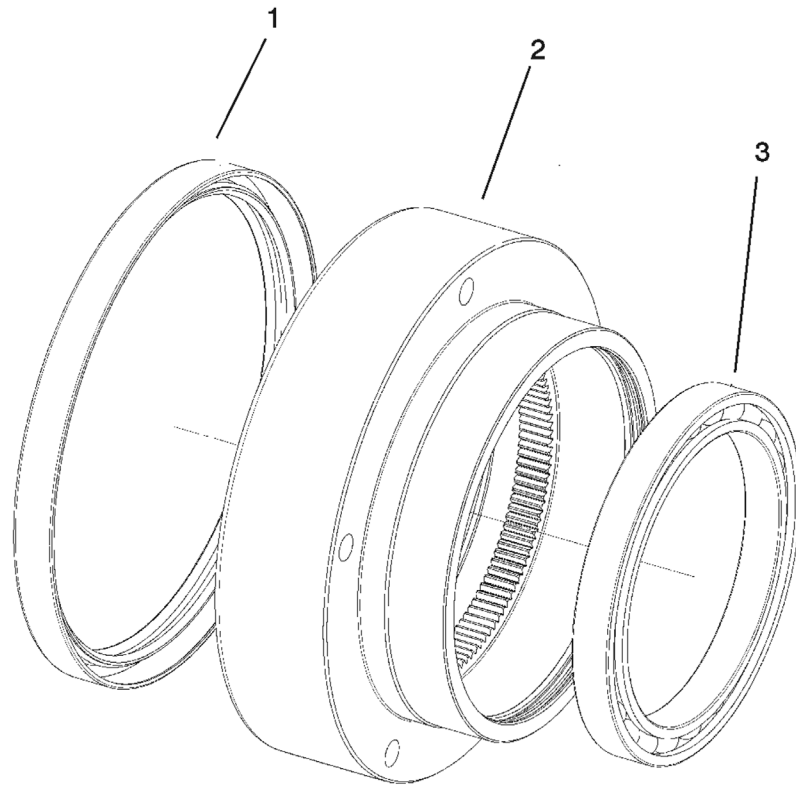

Figure 3-37. Hub Assembly

- | | |
|---------|-----------------|
| 1. Seal | 3. Main Bearing |
| 2. Hub | |

1. Put hub on a table with the tapped holes facing down.
2. Using a flat plate in conjunction with a pressing tool, press in the seal so it is flush with the edge of the hub.
3. Flip the hub over.
4. Using an appropriate pressing tool, press the main bearing into the bore until it bottoms out.

NOTE: *The seal has a thin outer shell that can be easily damaged if not installed with care. It is a good idea to start the seal into the bore with a rubber mallet before pressing.*

Input Carrier Assembly

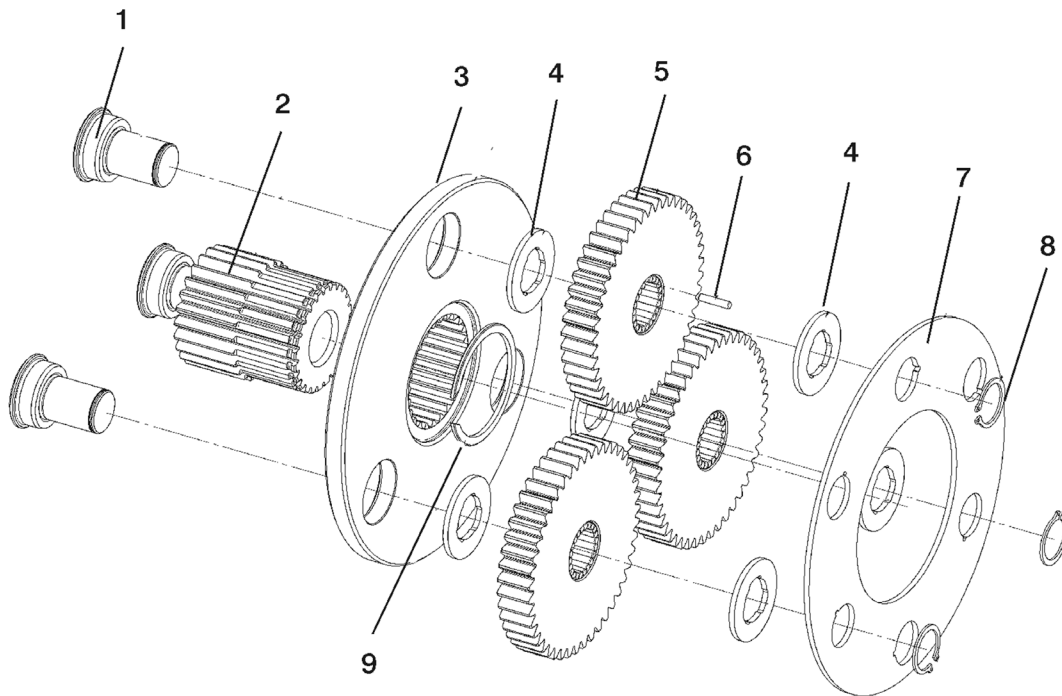

Figure 3-38. Input Carrier Assembly

- | | |
|----------------------|--------------------|
| 1. Planet Gears | 6. Needle Bearings |
| 2. Output Sun Gears | 7. Thrust Plate |
| 3. Input Carrier | 8. Snap Ring |
| 4. Thrust washer | 9. Retaining Ring |
| 5. Input Planet Gear | |

1. Press 3 input planet shafts into the 3 holes of the input carrier. The head of the input planet shaft needs to sit flush in the counter bore of the input carrier hole.
2. Insert output sun gear into the splined bore of the input carrier. The gear tooth end of the output sun gear should protrude in the opposite direction of the input planet shaft.
3. Using retaining ring pliers, install the retaining ring into the groove of the output sun gear. Make sure that the ring is correctly seated in the groove and that the output sun gear cannot be pulled out of the input carrier.
4. Load 22 needle rollers into the bore of each input planet gear. Retain the needle bearings in the bore with a coating of grease.
5. Place a thrust washer on each side of the input planet gear. Line up the bores as well as you can visually. Additional grease may help hold everything together.
6. Place the input planet gear and thrust washers onto the input planet shaft sticking out from the carrier. When you slide the input planet shafts into the bores, the needle bearings will try to push out. If you have the thrust washers lined up properly they will contain the needle bearings within the input planet gear.
7. Repeat 5 & 6 for the other 2 planet gears.
8. Put the thrust plate onto the three input planet shafts. Use the 3 holes on the innermost bolt circle. The other 3 holes are for a different gear ratio.
9. Using the appropriate retaining ring pliers put a retaining ring into the groove of each planet shaft.

NOTE: Do not overstress the snap ring.

Main Gearbox Assembly

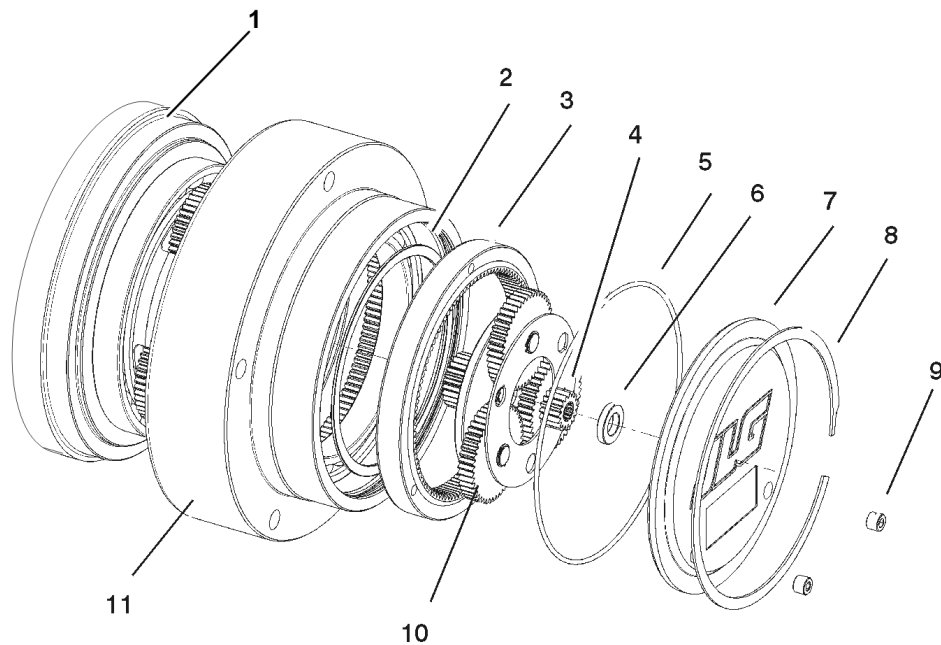

Figure 3-39. Main Gearbox Assembly

- | | | |
|-------------------------|------------------------|--------------------------------|
| 1. Spindle Sub-Assembly | 5. Cover O-Ring | 9. Pipe Plug |
| 2. Spiral Snap Ring | 6. Cover Thrust Washer | 10. Input Carrier Sub-Assembly |
| 3. Input ring Gear | 7. Cover | 11. Hub Sub-Assembly |
| 4. Input Sun Gear | 8. Cover Snap Ring | |

1. Inspect seal surface of spindle. Remove any debris that may be present.
 2. Apply a coating of grease to the lip seal of the hub sub-assembly.
 3. Place Spindle Sub-Assembly on table with carrier side up.
 4. Carefully install the hub sub-assembly (seal side down) onto the spindle. This installation should be a slip fit and takes place in 3 stages.
 - a. *Stage 1:* The hub slides together until the gear teeth of the hub hit the gear teeth of the 3 output planets.
 - b. *Stage 2:* Find the planet gear that is tight and turn it until you feel it go into mesh with the hub gear teeth, apply slight downward pressure to the hub and then find the next gear that is tight and do the same.
 - c. *Stage 3:* Once all the planet gears are in mesh apply pressure to the hub, it should go on the rest of the way.
 5. Install retaining ring into the groove on the outside diameter of the spindle carrier. This is a spiral retaining ring so it will not require pliers. You will need to pull the retaining ring apart and work it into the groove.
 6. Using an appropriate pressing tool, press the Input Ring gear (**recessed side down**) into the hub subassembly.
- NOTE:** Do not use excessive pressing force because it will be reacted by the main wheel bearings.
7. Install the input carrier sub-assembly into mesh. The output sun portion of the sub-assembly will mesh with the output planet gears and the planet gears mounted on the sub assembly will mesh with the input ring gear.
 8. Install the input sun gear into the area between the 3 input planet gears.

SECTION 3 - CHASSIS & SCISSOR ARMS

9. Apply a coating of grease to the cover o'ring and install it into the o'ring groove of the hub.

NOTE: *It may be helpful to stretch the o'ring out prior to assembly to avoid pinching or shearing when the cover is assembled.*

10. Apply a heavy coating of grease to the cover thrust washer and place it in the center counter bore of the cover. The grease will help keep it in the bore during assembly.
11. Center the cover in the hub bore so that the "JLG" logo is up. Push it into the bore.

NOTE: *Do not hit the cover with a hammer or mallet, shocks may cause the cover thrust washer to dislodge and drop into the gear cavity prior to the cover getting positioned properly. If all the parts are to size and assembled properly, the cover should not need excessive force to assemble.*

12. Install the cover retaining ring into the hub groove.
13. Re-install drive motor to torque hub per instructions Drive Motor Installation - page 3-25, install on machine.
14. Test per instructions in Section 3.14, Torque Hub Servicing, for proper operation and to check for any oil leaks.

3.15 STEER ASSEMBLY COMPONENTS

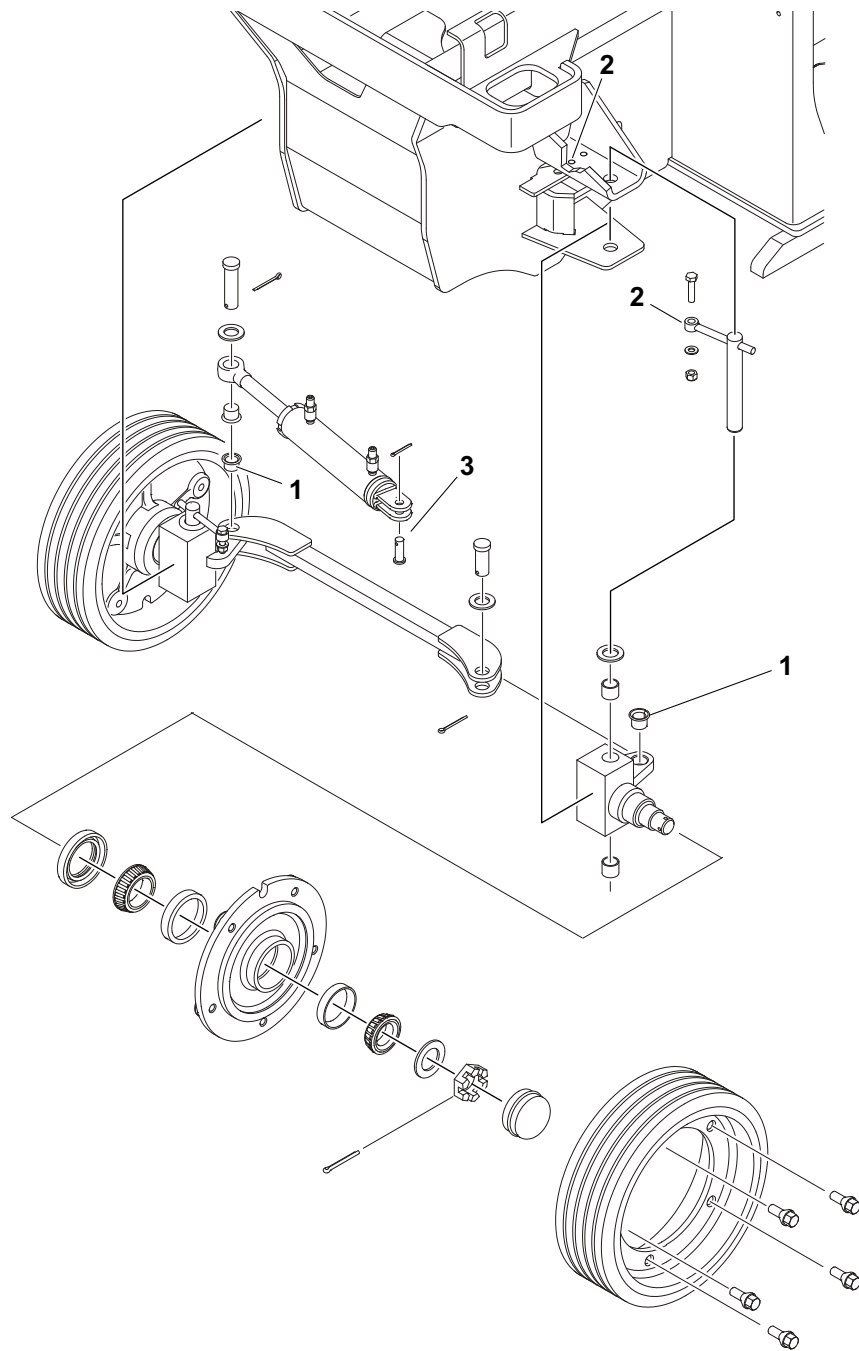

Figure 3-40. 1932RS/6RS - Steer Assembly

NOTE: Coat all pins with a light coat of molypaste before assembly. Pack inner and outer spindle bearings with multi-purpose grease (MPG) before assembly. Do not overtighten spindle bearing nut. Replace spindle seal if worn, damaged, or leaking.

1. Install the bearing with the flange surface on top of the spindle arm.
2. Assemble the spindle kingpin attach, banjo pin hardware, in the frame hole towards the front of the machine.
3. Install cylinder to frame attach pin with cotter pin hole on top.

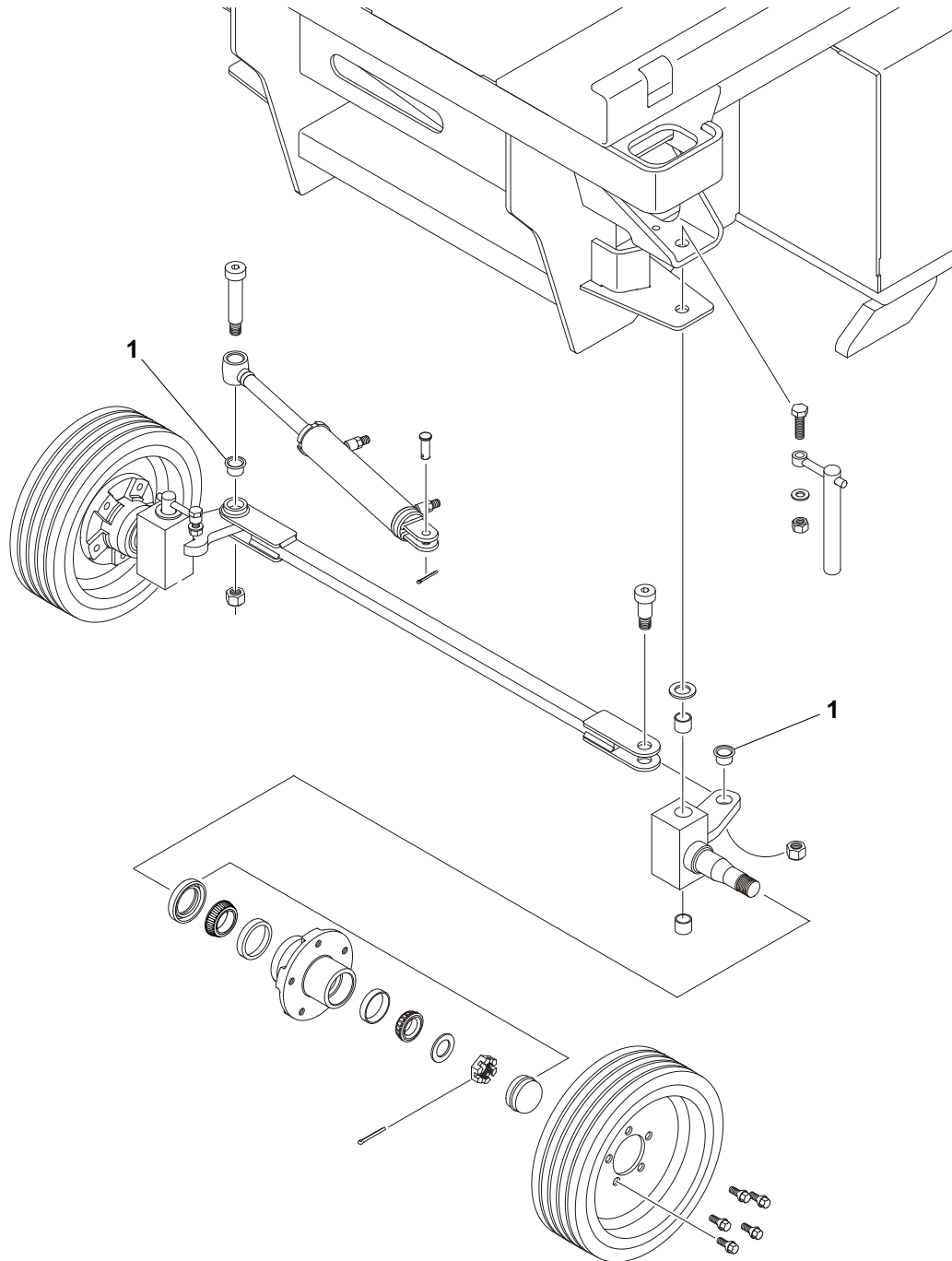

Figure 3-41. 3248RS/10RS - Steer Assembly

NOTE: Coat all pins with a light coat of molypaste before assembly. Pack inner and outer spindle bearings with multi-purpose grease (MPG) before assembly. Do not overtighten spindle bearing nut. Replace spindle seal if worn, damaged, or leaking.

1. Install the bearing with the flange surface on top of the spindle arm.

3.16 ARMS AND PLATFORM POSITIONING AND SUPPORT

⚠ WARNING

NEVER WORK UNDER AN ELEVATED PLATFORM UNTIL IT HAS BEEN RESTRAINED FROM MOVEMENT WITH SAFETY PROPS, BLOCKING OR OVERHEAD SLING.

The arm stack can be supported by using an overhead crane. (See Figure 3-42.). If an overhead crane is not available the stack may also be lifted by using a fork-truck using the following instructions:

1. With the forks on the fork-truck slid close together, enter from the front of the machine and place the forks on the cross tube of the second arm assembly below the platform.
2. Slowly lift the arm stack with the fork-truck while the manual descent valve is being engaged (this allows the oil to drain back into the tank).
3. Place machine on safety prop and leave the fork truck in place.
4. At this point the lift cylinder removal may begin. (Refer to Section 4.6, Lift Cylinder Removal)

If removal of the platform becomes necessary use the above procedure to stabilize the platform for pin and platform removal.

3.17 PLATFORM REMOVAL

1. Support the platform using an overhead crane with straps capable of lifting at least 500 lbs (227 kg) (See Figure 3-42.). Refer to Section 3.16, Arms and Platform Positioning and Support.
2. Disconnect and remove the platform control station and wiring harness at the platform. Disconnect AC receptacle cable if applicable. Route the cables out through the hole at the right-rear of the platform to free platform of any constraints when lifting.
3. Remove the bolts attaching the pins and slide blocks at each corner to the arm stack. Carefully remove the four pins attaching the platform to the arm stack.
4. Lift the platform from the arm stack and set aside.

NOTE: When attaching platform back onto scissor arm assembly, follow removal procedures in reverse order.

3.18 SCISSOR ARMS REMOVAL

1. Remove platform (refer to Section 3.17, Platform Removal).
2. Disconnect all wiring and cables attached to scissor arm assembly.
3. The scissor arms can be removed as a complete unit or individually.

Removing Scissor Arm Assembly as a Complete Unit

1. Remove the pin attaching the bottom scissor arms to the rear of the frame by removing the bolt.
2. Place two straps around each end of the entire scissor arm assembly. Using an overhead crane, slowly and carefully move the arm stack forwards so that slide blocks at front of machine slide out the front of the slide channel on the frame.

NOTE: Overhead crane and straps must be capable of lifting at least 2000 lbs (907 kg).

3. Once slide blocks are clear of machine, the scissor stack can be moved to a more desirable location for further arm disassembly.

Removing/Installing Scissor Arms Individually

See Figure 3-43., Figure 3-44., Figure 3-45. and Figure 3-46.

1. With the platform removed, start with the top arms (closest to platform).
2. Secure each arm section being removed using an overhead crane with suitable lifting straps.
3. Remove the bolts securing the connecting pins in place.
4. Remove the pins from the arms.
5. Remove the arm section from the machine using the overhead crane.
6. Repeat previous steps for remaining arm sections.

NOTE: When attaching scissor arm assembly back onto frame, follow removal procedures in reverse order.

Self locking fasteners, such as nylon insert and thread deforming locknuts, are not intended to be reinstalled after removal. Always use new replacement hardware when installing locking fasteners.

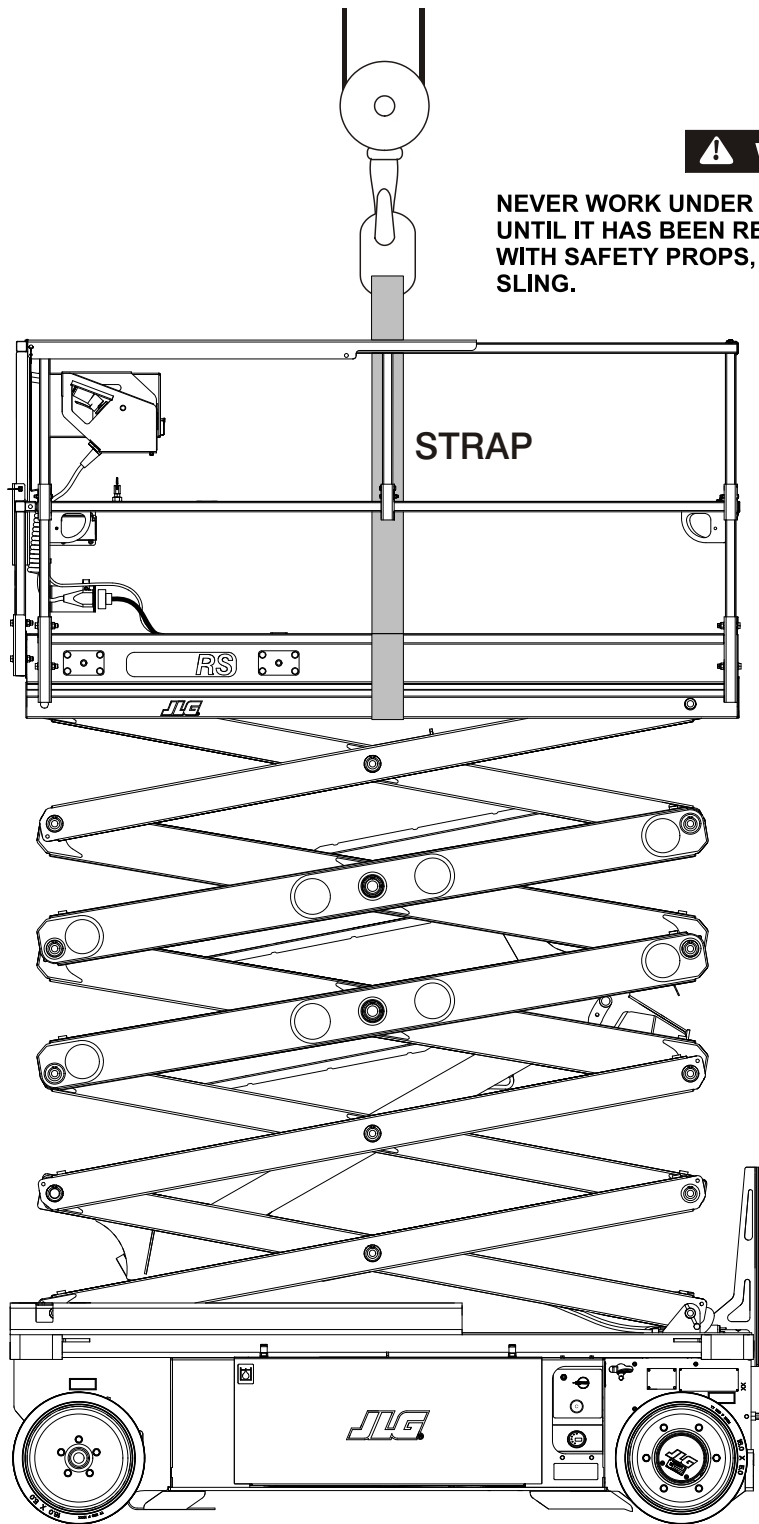

⚠ WARNING

NEVER WORK UNDER AN ELEVATED PLATFORM UNTIL IT HAS BEEN RESTRAINED FROM MOVEMENT WITH SAFETY PROPS, BLOCKING OR OVERHEAD SLING.

Figure 3-42. Arms and Platform Positioning and Support

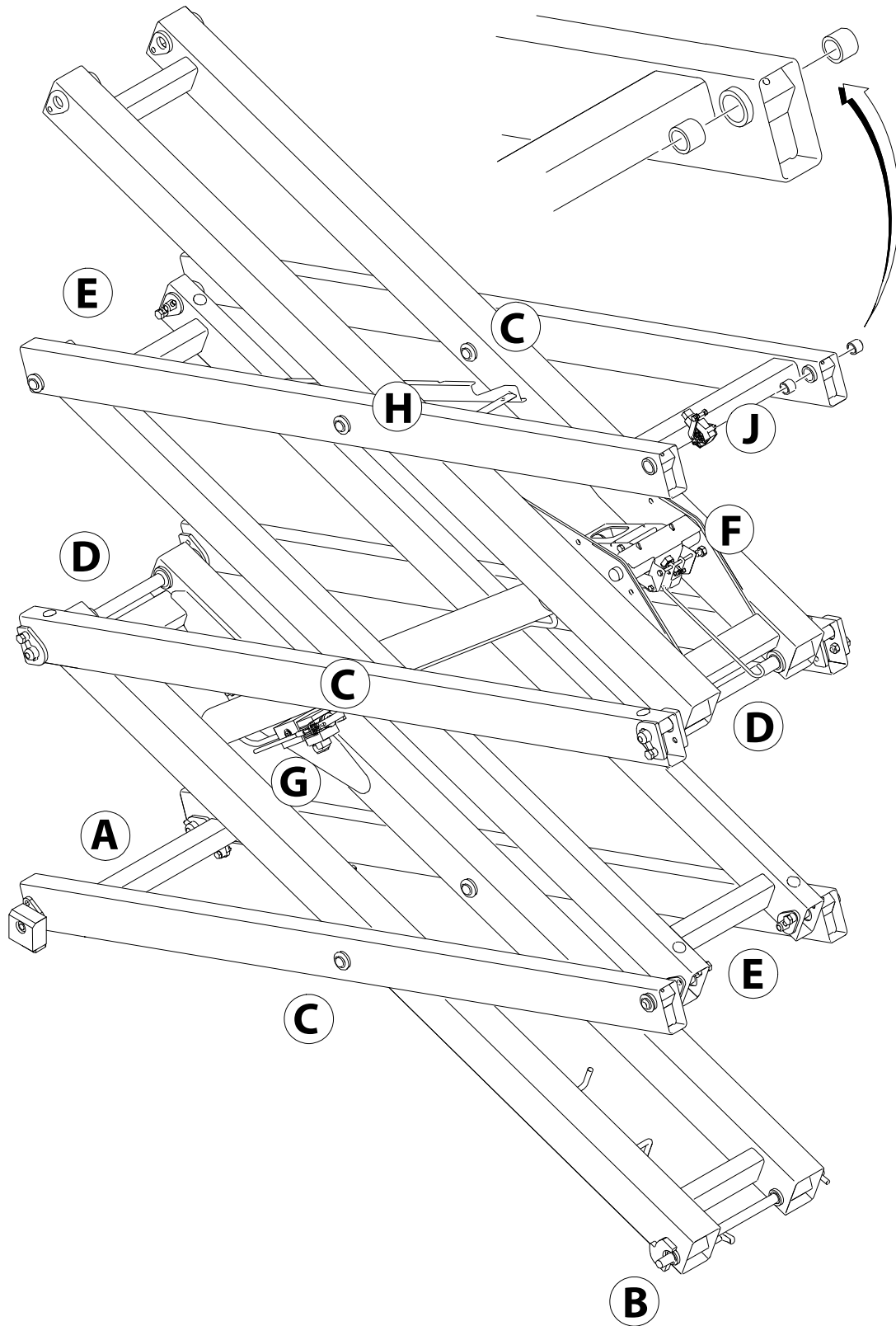

Figure 3-43. 1932RS/6RS - Scissor Arm Assembly

MAF02440

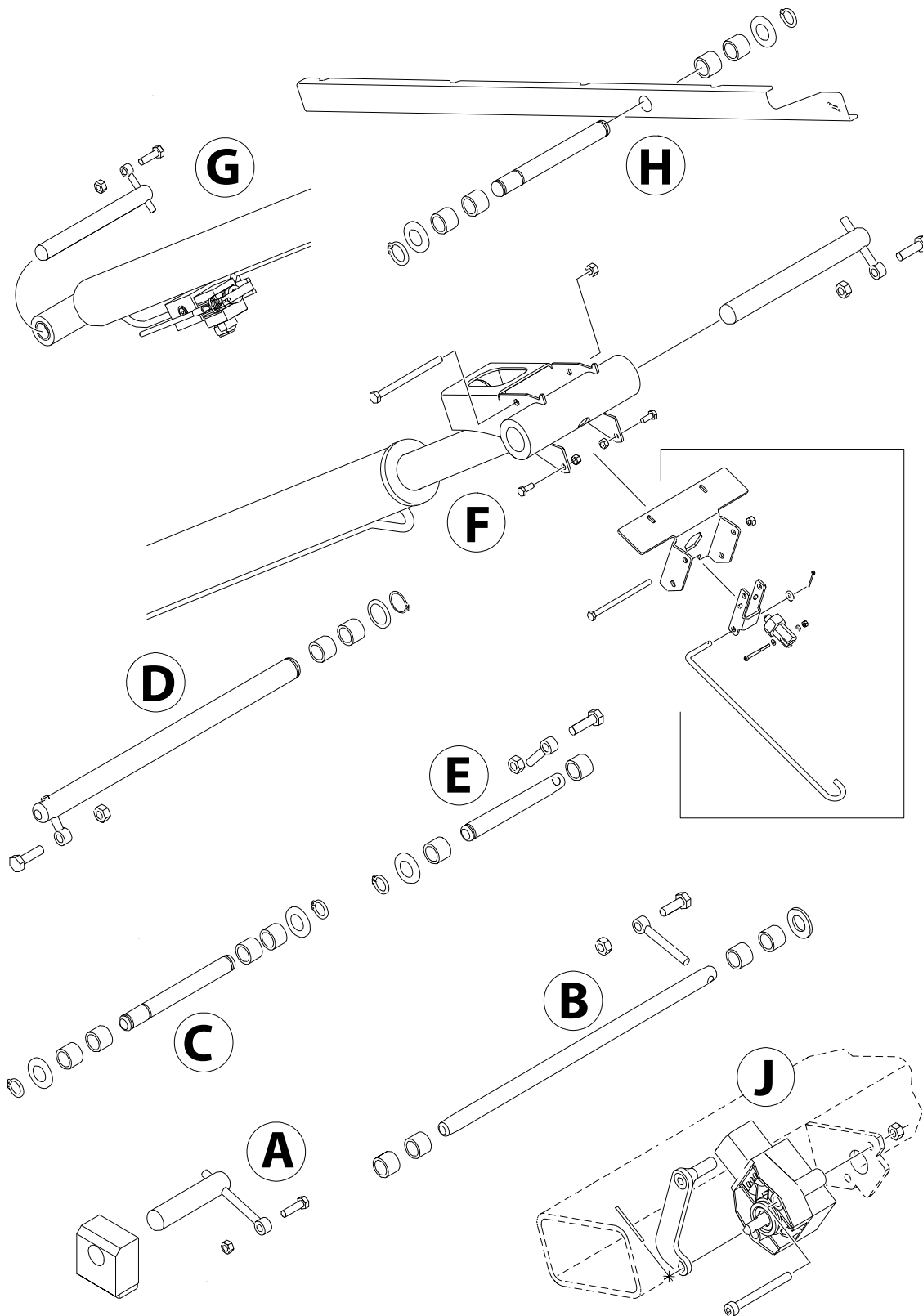
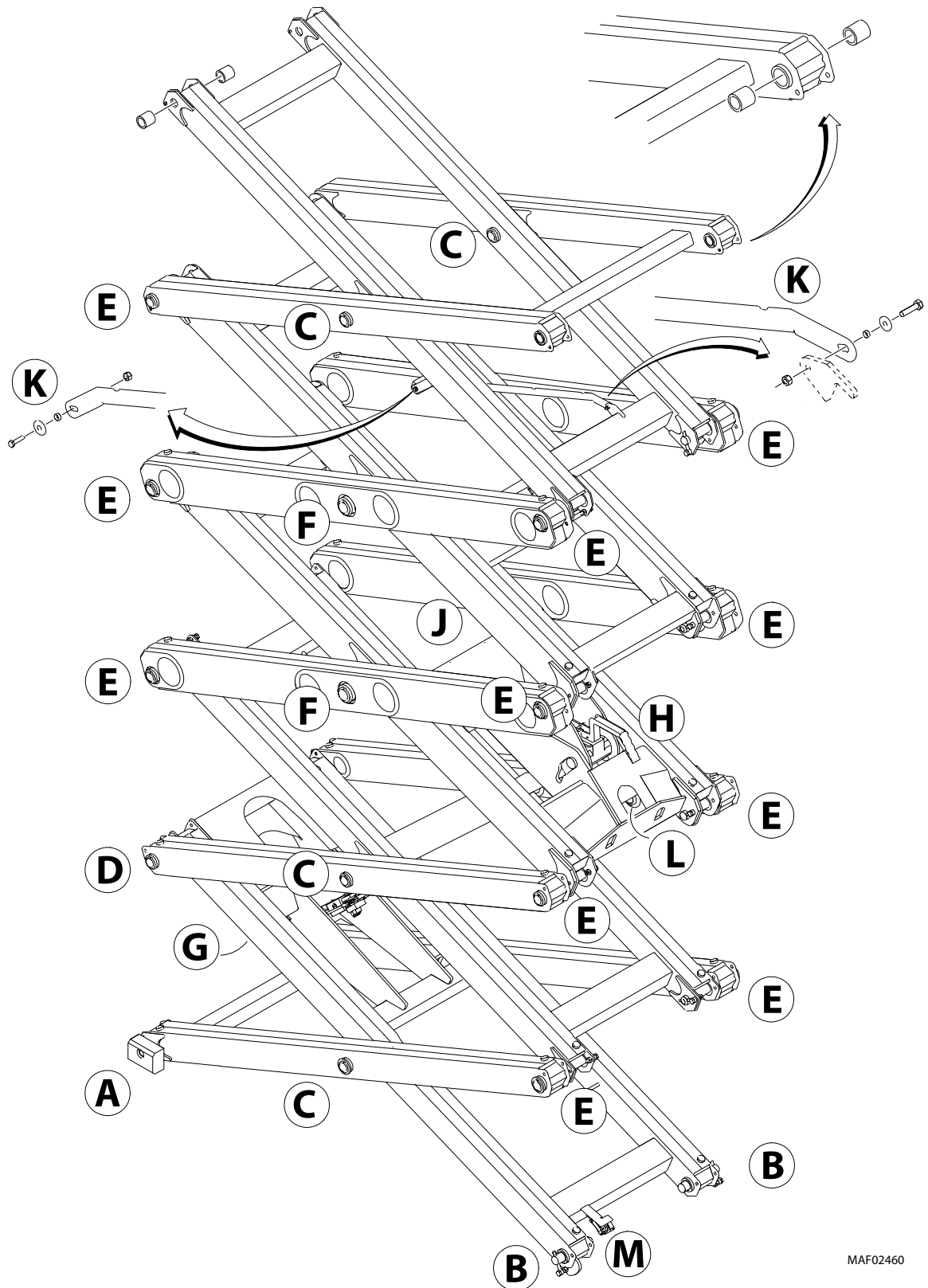

Figure 3-44. 1932RS/6RS - Scissor Arm Assembly - Pin Configuration

MAF02450



MAF02460

Figure 3-45. 3248RS/10RS - Scissor Arm Assembly

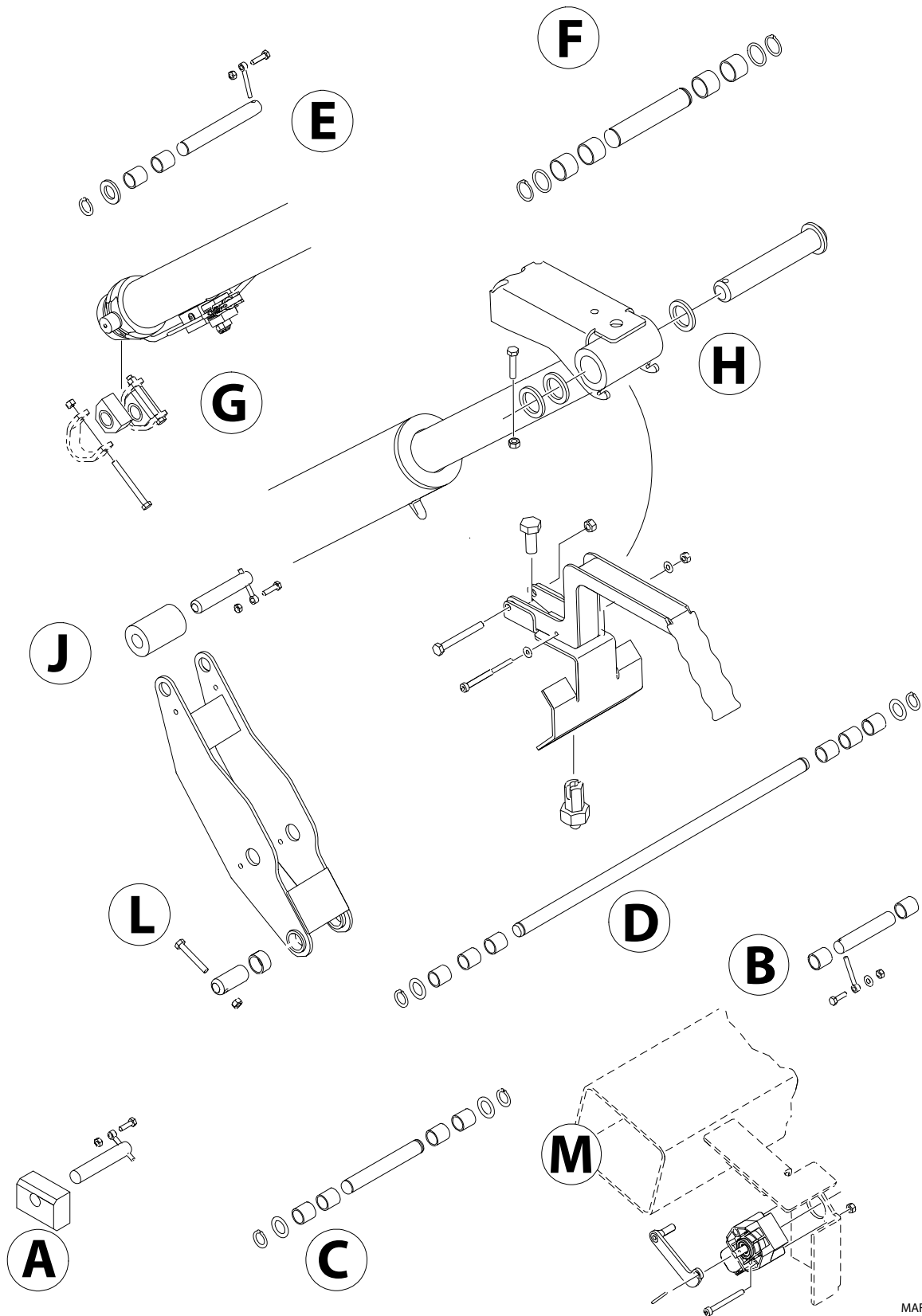

MAF02470

Figure 3-46. 3248RS/10RS - Scissor Arm Assembly - Pin Configuration

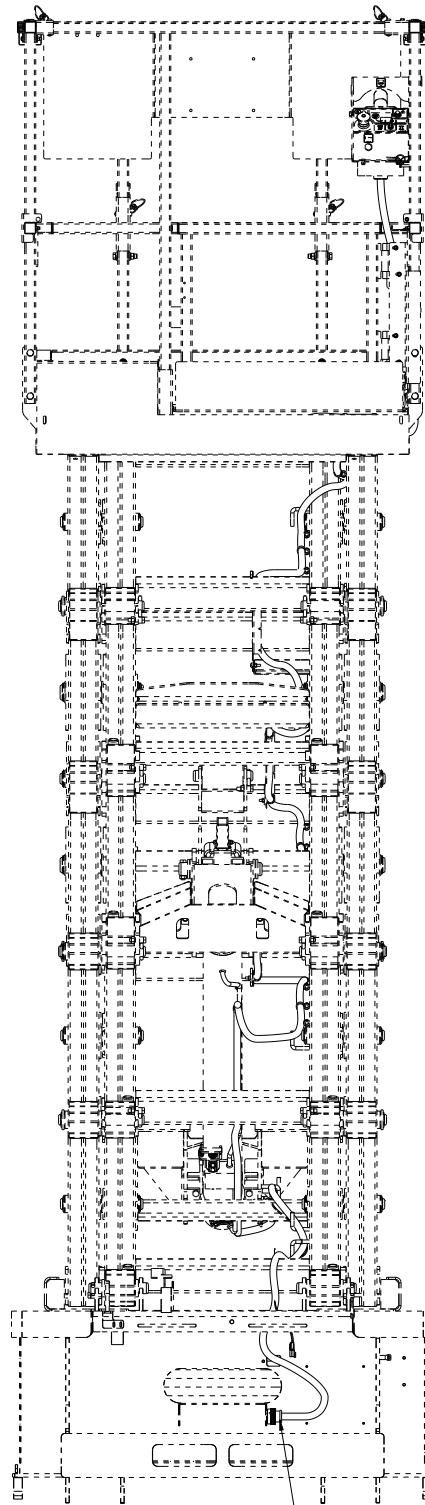

SECURE CHASSIS CONNECTOR (X11) OF PLATFORM CABLE
TO CHASSIS HARNESS WITH TIE STRAP

1001196746-B
MAF03360

Figure 3-47. Platform cable (3248RS/10RS) - Sheet 1 of 4

SECTION 3 - CHASSIS & SCISSOR ARMS

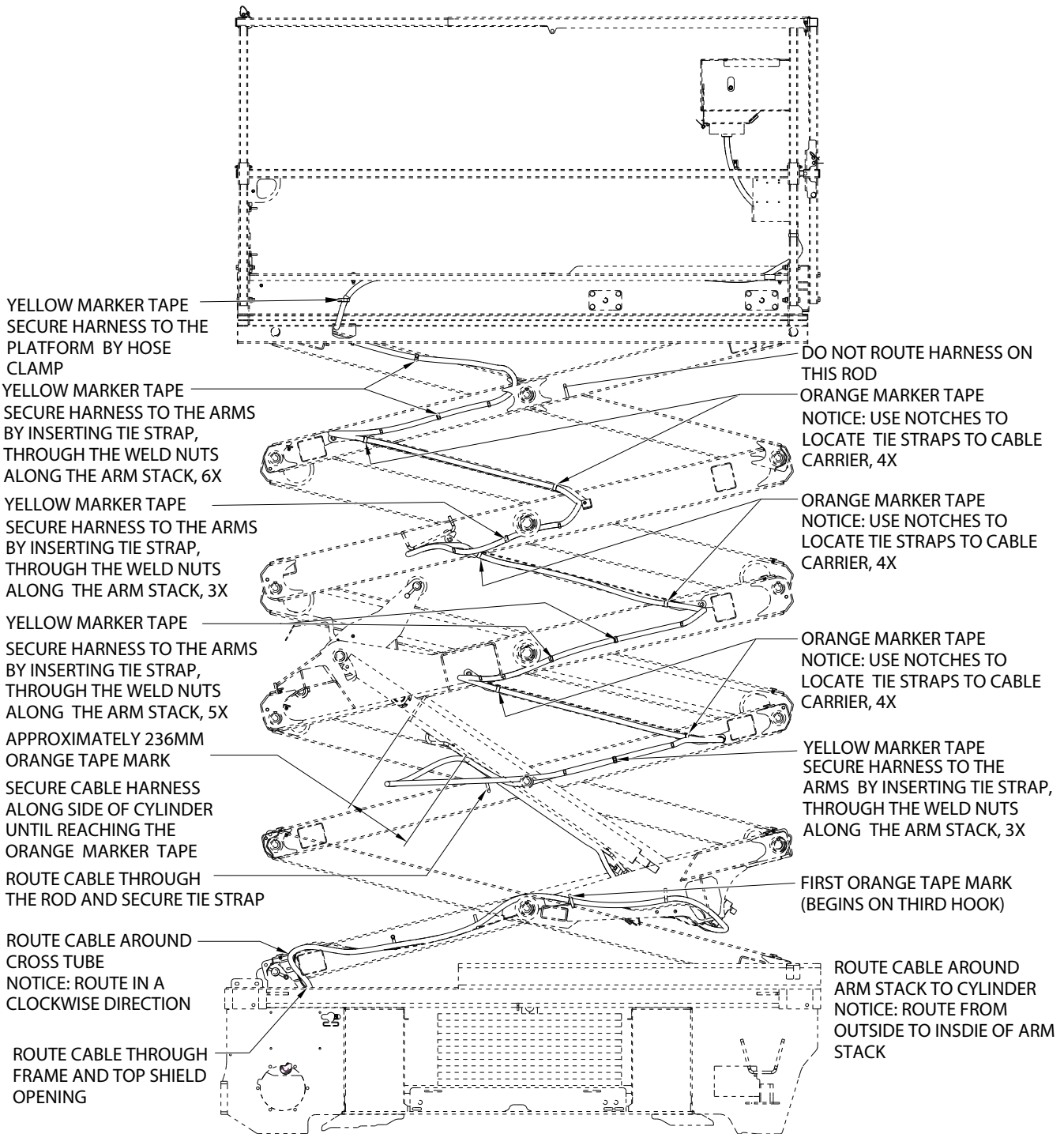

NOTES:

1. ORANGE AND YELLOW MARKER TAPE STRIPS ARE LOCATED ON PLATFORM HARNESS TO ASSIST IN INSTALLATION.
2. AT EVERY YELLOW MARKER, SECURE THE HARNESS TO THE NUTS WELDED ON THE ARMS USING TIE STRAP. UNLESS OTHERWISE SPECIFIED
3. AT EVERY ORANGE MARKER, SECURE THE HARNESS TO THE CABLE CARRIER USING WIRE TIE STRAP.
4. ADDITIONAL TIE STRAPS SHOULD BE USED TO FIRMLY ATTACH THE HARNESS TO THE MACHINE.

1001196746-B
MAF03370

Figure 3-48. Platform cable (3248RS/10RS) - Sheet 2 of 4

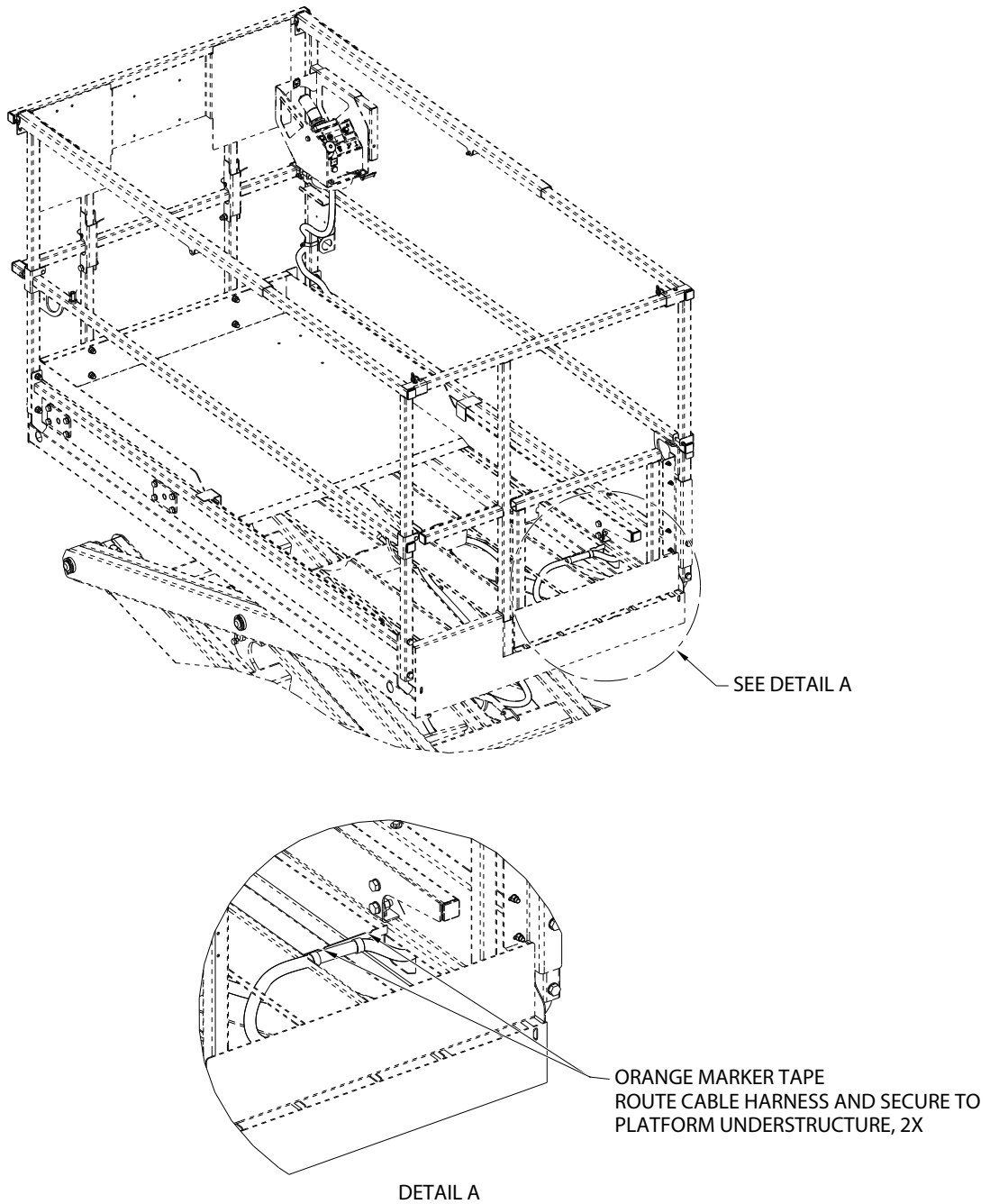

1001196746-B
MAF03380

Figure 3-49. Platform cable (3248RS/10RS) - Sheet 3 of 4

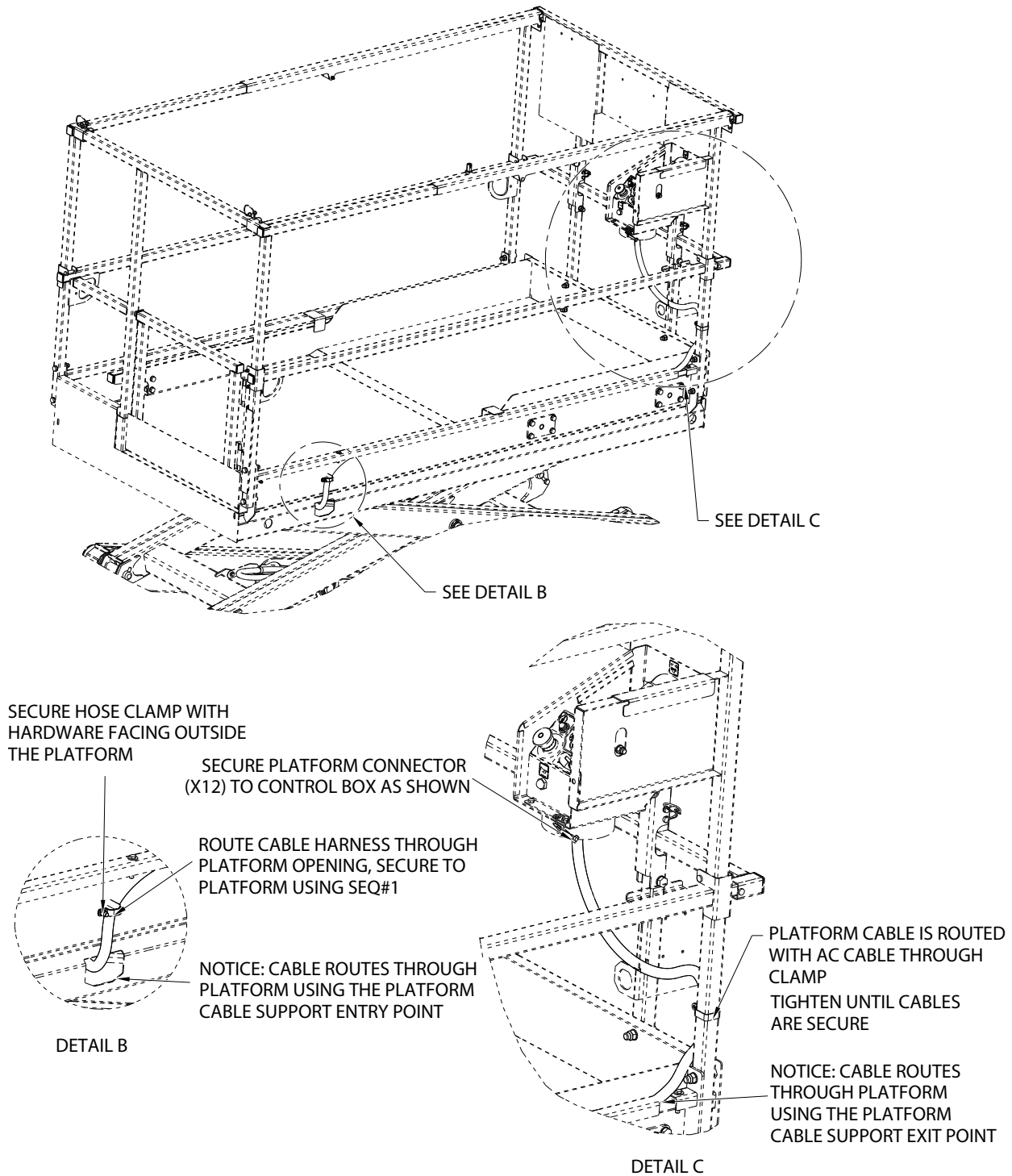

1001196746-B
MAF03390

Figure 3-50. Platform cable (3248RS/10RS) - Sheet 4 of 4

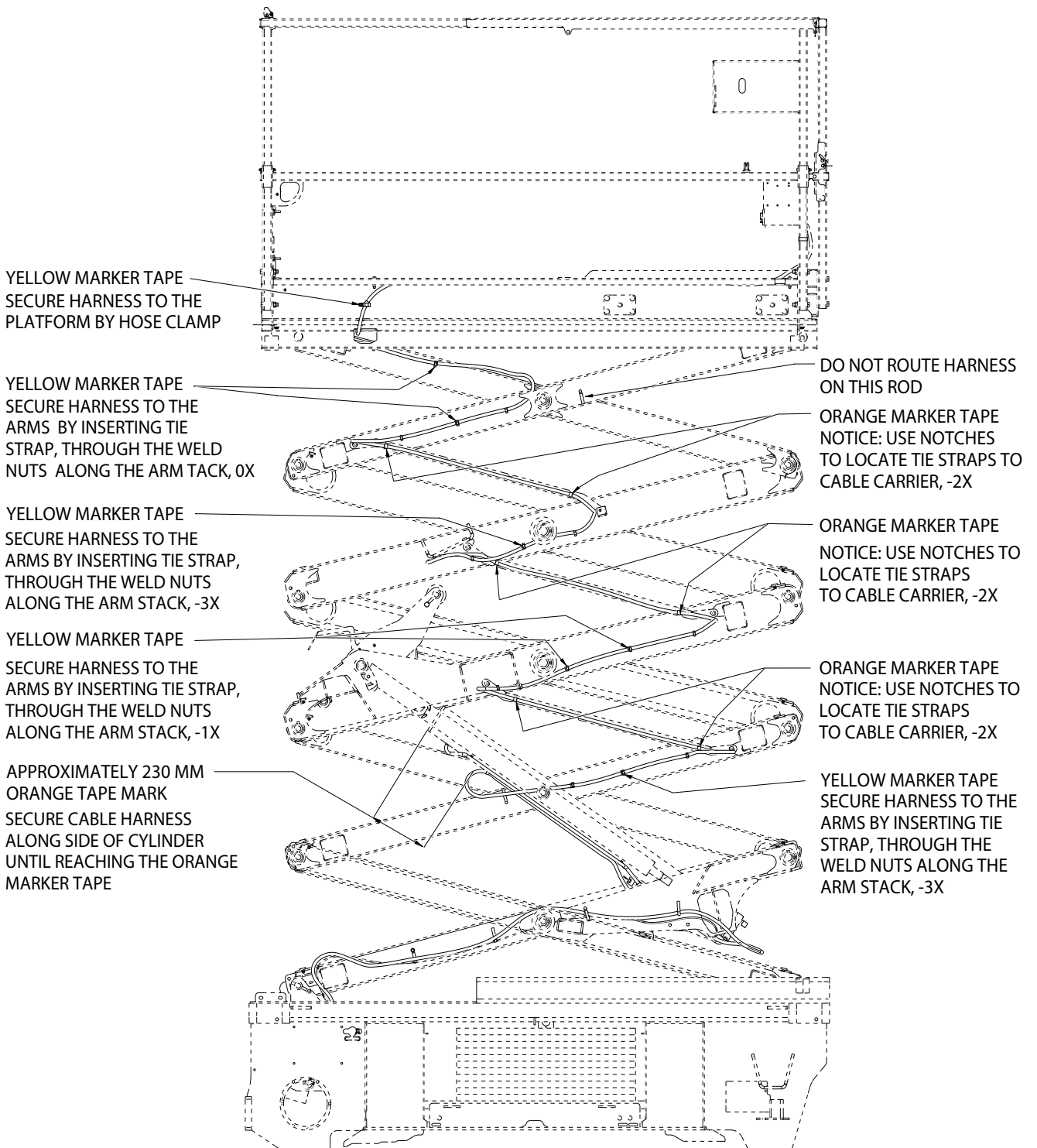

NOTES:

1. ORANGE AND YELLOW MARKER TAPE STRIPS ARE LOCATED ON PLATFORM CABLE HARNESS TO ASSIST IN INSTALLATION.
2. AT EVERY YELLOW MARKER TAPE, SECURE THE HARNESS TO THE NUTS WELDED ON THE ARMS USING WIRE TIE STRAP.
3. AT EVERY ORANGE MARKER TAPE, SECURE THE HARNESS TO THE CABLE CARRIER USING WIRE TIE STRAP.
4. ADDITIONAL TIES SHOULD BE USED TO FIRMLY ATTACH THE HARNESS TO THE MACHINE.

Figure 3-51. Platform cable (LSS - 3248RS/10RS) - Sheet 1 of 3

1001147239-E
MAF02430

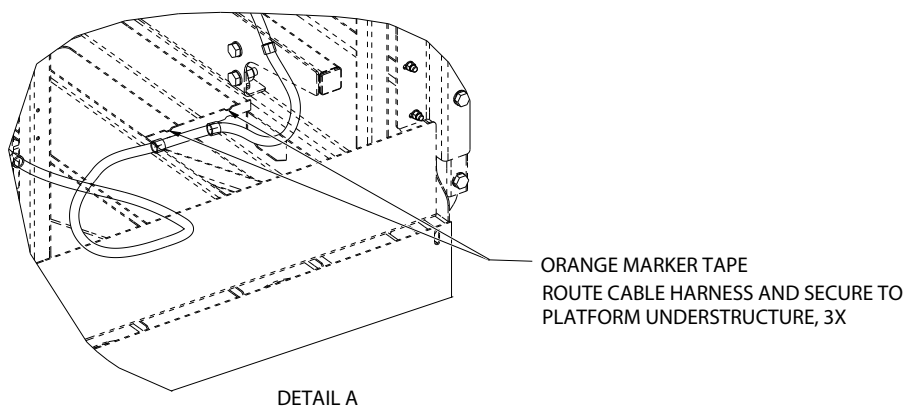
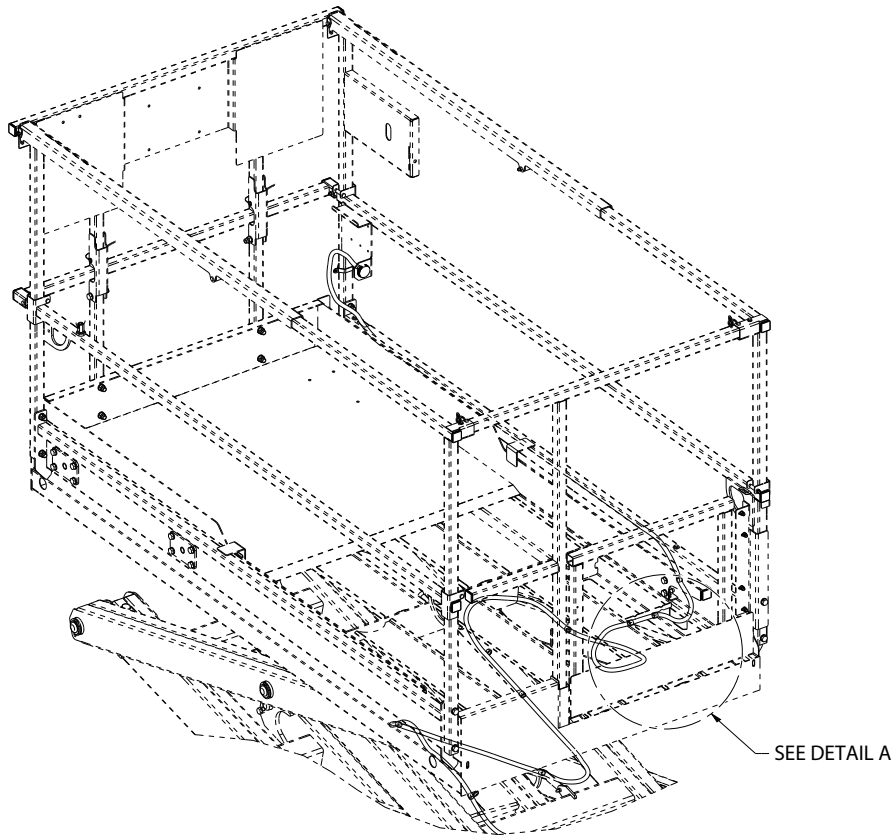

1001147249-E
MAF02600

Figure 3-52. Platform cable (LSS - 3248RS/10RS) - Sheet 2 of 3

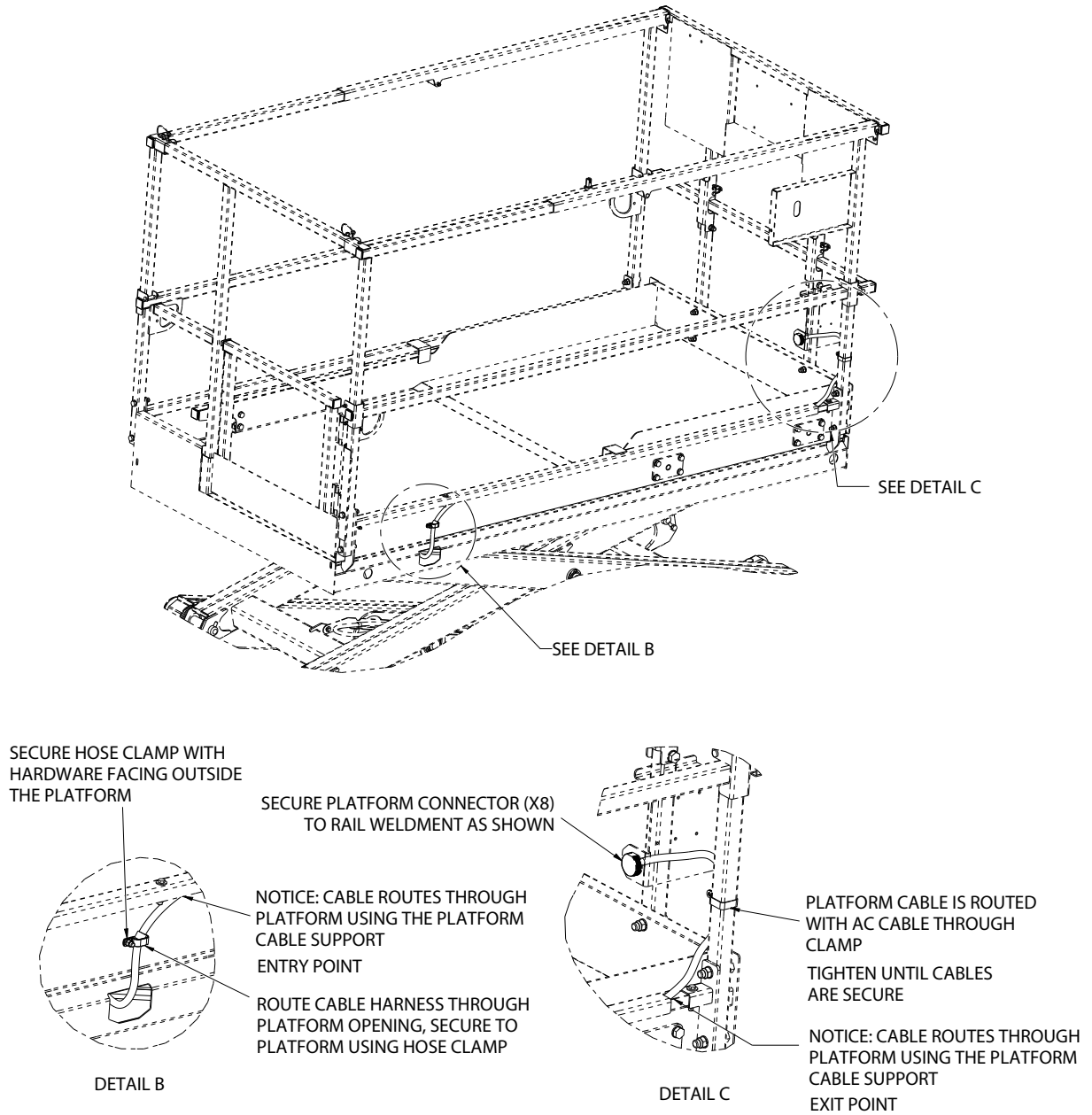

1001147249-E
MAF02610

Figure 3-53. Platform cable (LSS - 3248RS/10RS) - Sheet 3 of 3

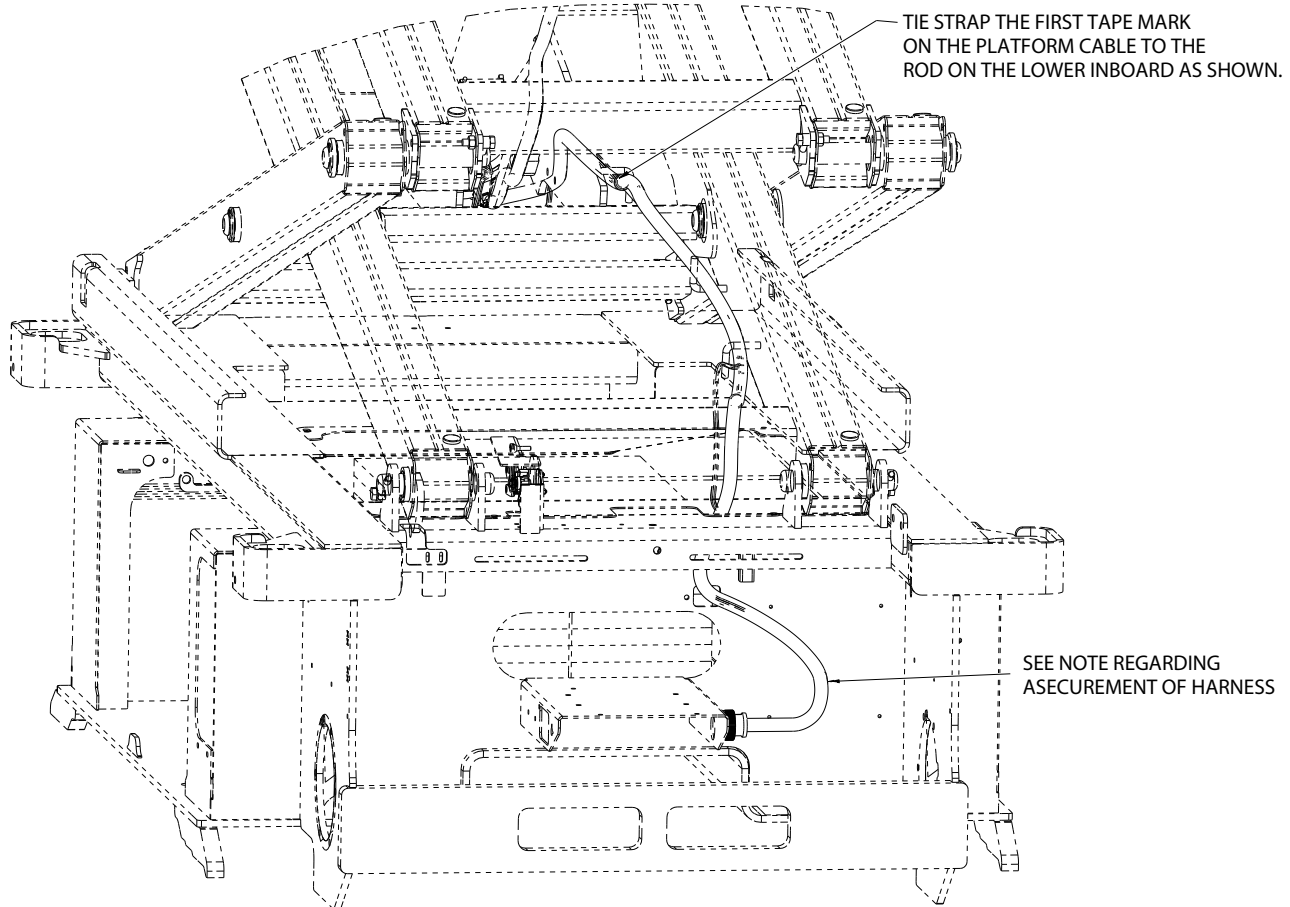

NOTES:

1. ORANGE AND YELLOW MARKER TAPE STRIPS ARE LOCATED ON PLATFORM CABLE HARNESS TO ASSIST IN INSTALLATION.
2. AT EVERY YELLOW MARKER TAPE, SECURE THE HARNESS TO THE NUTS WELDED ON THE ARMS USING WIRE TIE STRAP.
3. AT EVERY ORANGE MARKER TAPE, SECURE THE HARNESS TO THE CABLE CARRIER USING WIRE TIE STRAP.
4. ADDITIONAL WIRE TIES SHOULD BE USED TO FIRMLY ATTACH THE HARNESS TO THE MACHINE.

1001196745-B
MAF02960

Figure 3-54. Platform cable (FTSW - 3248RS/10RS) - Sheet 1 of 4

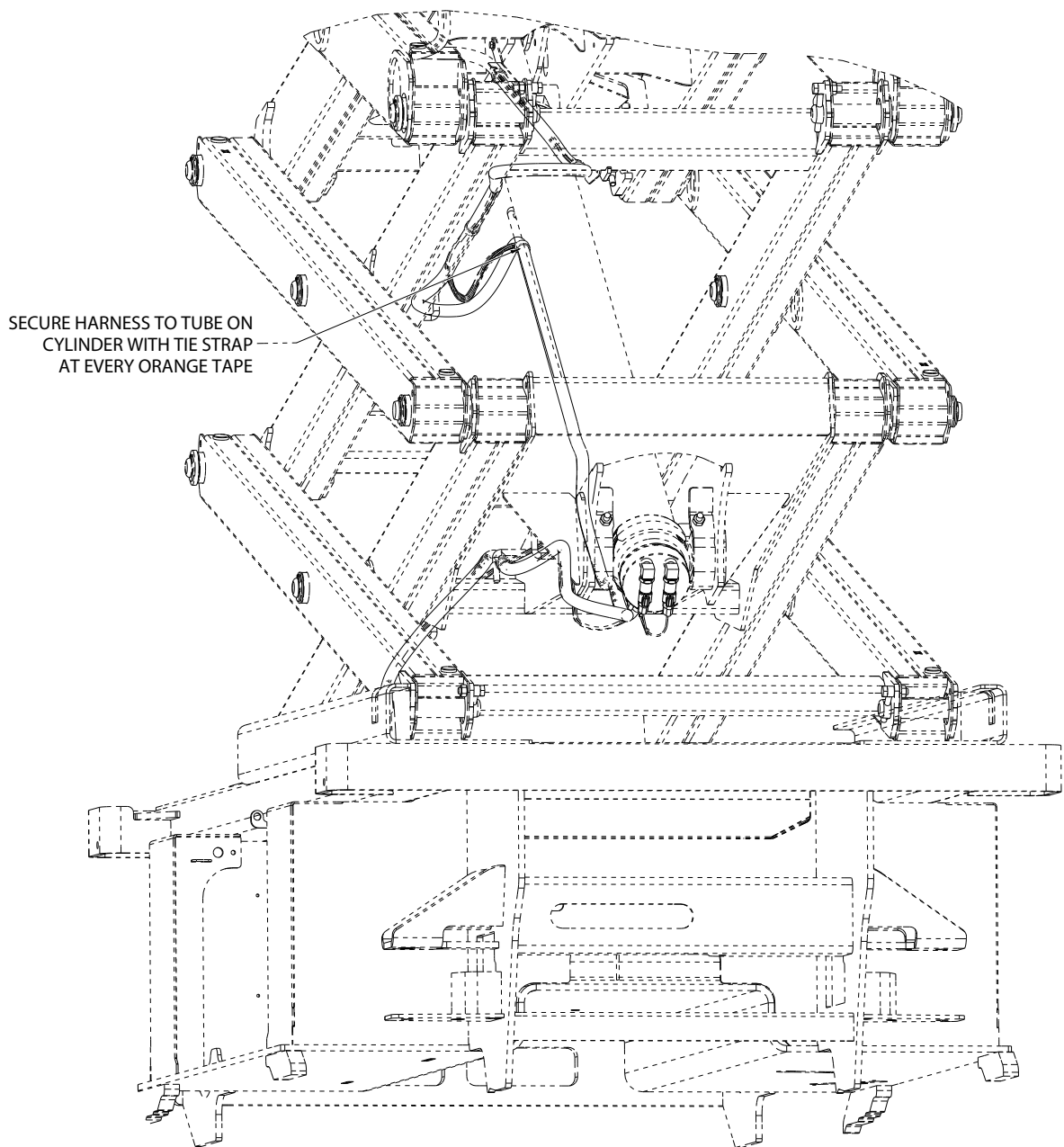

1001196745-B
MAF02970

Figure 3-55. Platform cable (FTSW - 3248RS/10RS) - Sheet 2 of 4

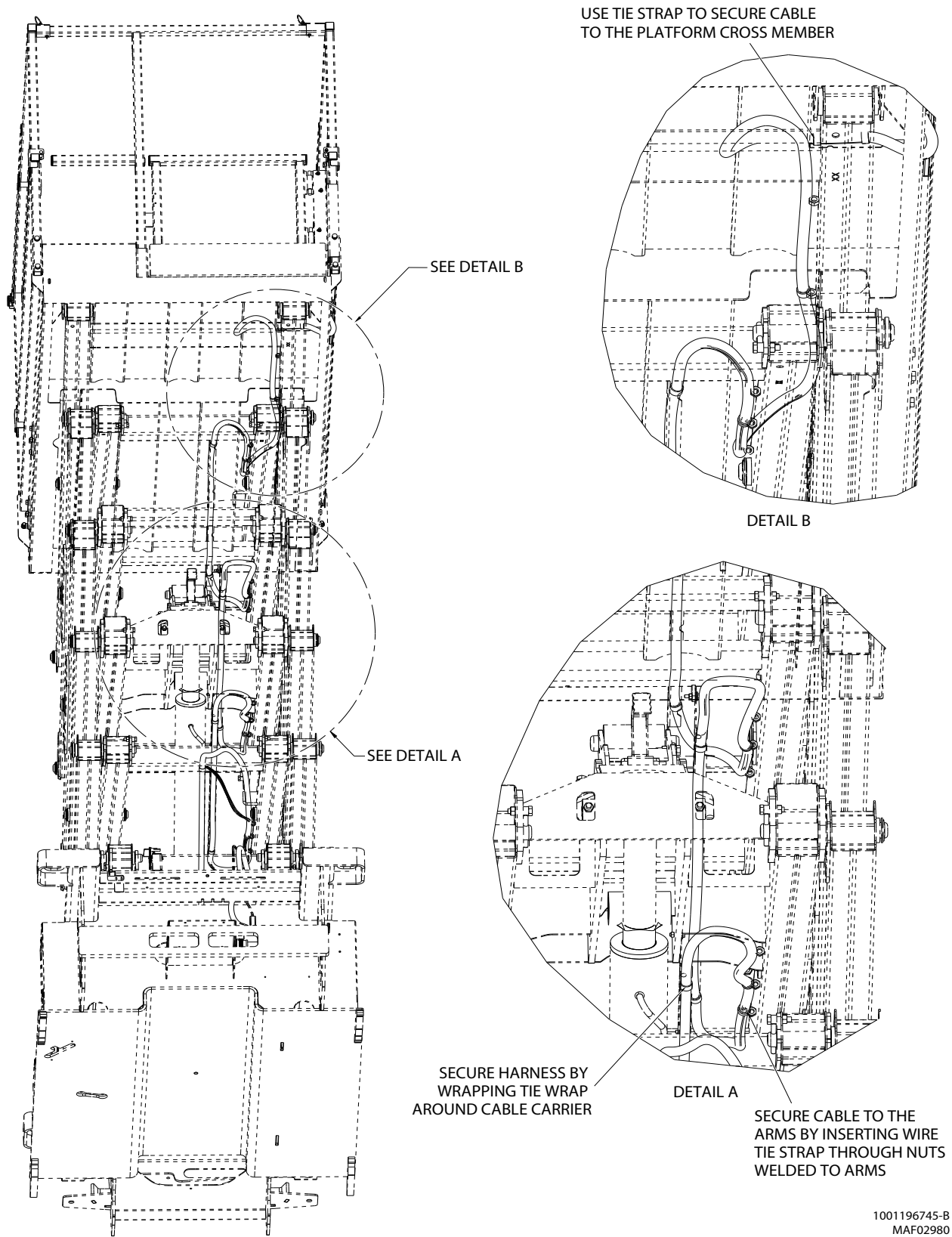

Figure 3-56. Platform cable (FTSW - 3248RS/10RS) - Sheet 3 of 4

1001196745-B
MAF02980

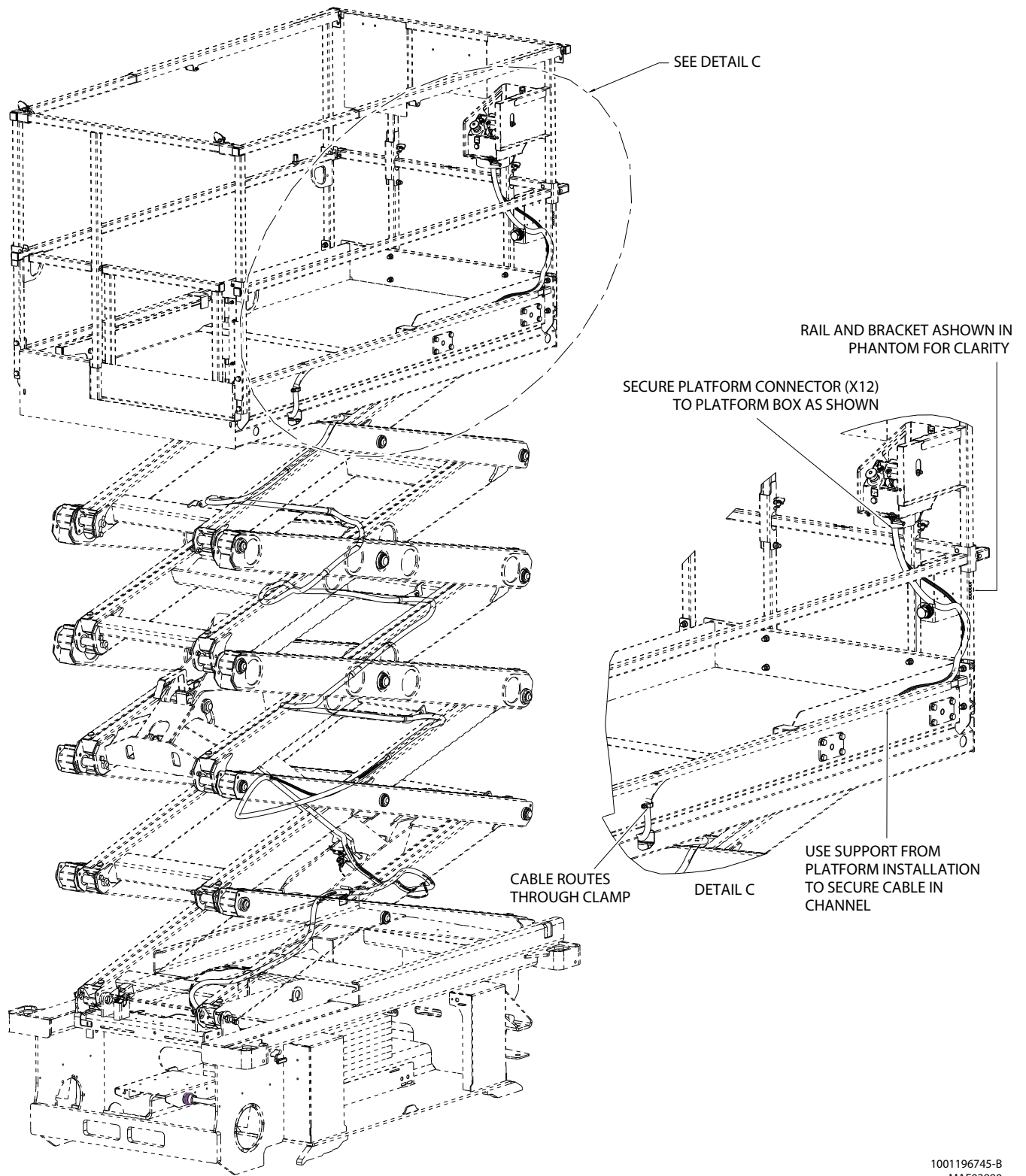

Figure 3-57. Platform cable (FTSW - 3248RS/10RS) - Sheet 4 of 4

3.19 PLATFORM CONTROL STATION

NOTICE

POWER MACHINE DOWN AT THE GROUND CONTROL STATION BEFORE DISCONNECTING THE PLATFORM CONTROL STATION.

Installation/Removal

1. Disconnect the platform control station harness at the connector below the control station mount.
2. Remove the pin securing the control station to the platform station mount, swing and lift to remove control station from the machine.

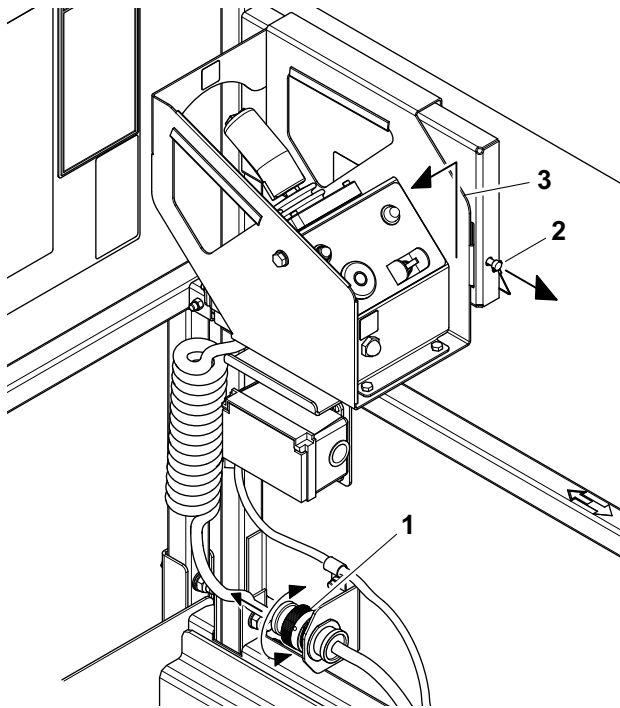

Figure 3-58. Platform Control Station Installation

- | | |
|----------------------|--------------------|
| 1. Harness Connector | 3. Lift and Remove |
| 2. Mounting Pin | |
3. To install, reverse steps 1 and 2 above.

Control Station Harness Installation to Scissor Arms

Below are a few notes for positioning and securing the platform control station harness to the scissor arms when installing or removing the harness on the machine.

- Orange and yellow marker tape strips are located on the platform harness to assist in installation.
- At every yellow marker tape, secure the harness to the nuts welded on the arms using wire ties.
- At every orange marker tape, secure the harness to the cable carrier using wire ties.
- If necessary, additional wire ties should be used to firmly attach the harness to the machine.

Control Station Disassembly

1. Place the platform control station assembly on a suitable work bench.
2. Remove the main body from the mount, by removing the long through bolt, cap-nut and washers (item 1) and the two (2) bolts and nuts (item 2) along the rear edge.

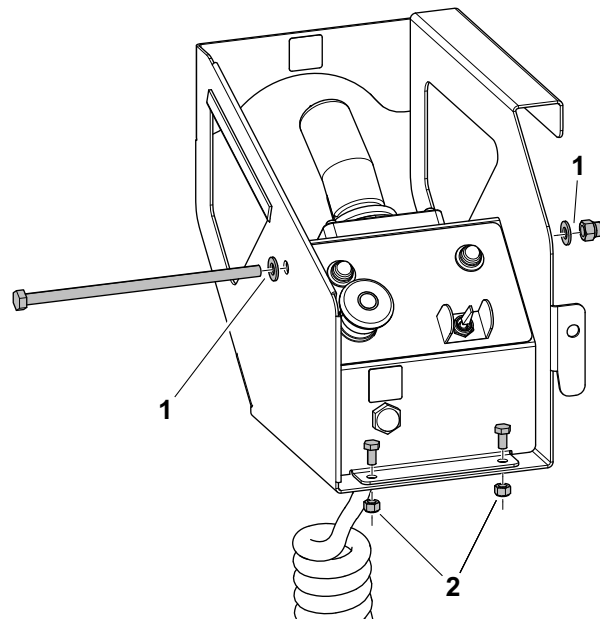

Figure 3-59. Platform Control Station Disassembly

- | | |
|--------------------------------------|-----------------------------|
| 1. Through Bolt, Cap-nut and Washers | 2. Rear Edge Bolts and Nuts |
|--------------------------------------|-----------------------------|

Overview of Control Station Components

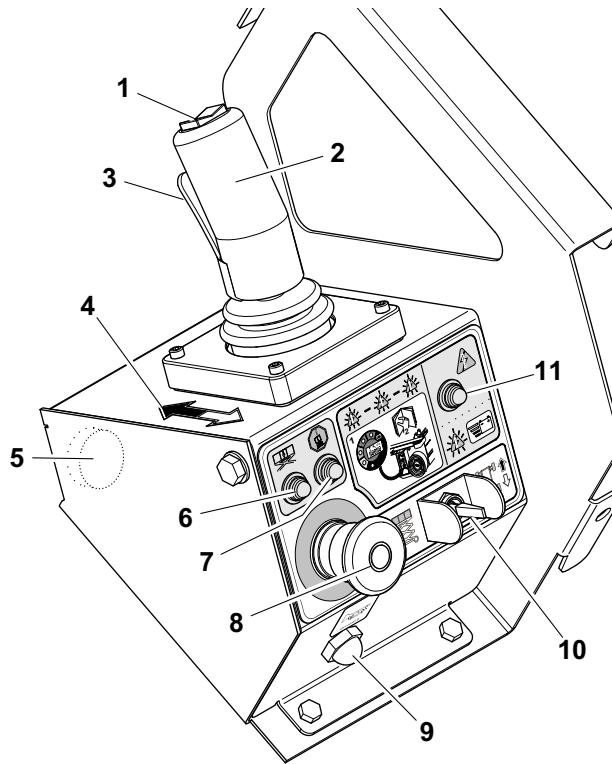

Figure 3-60. Platform Control Station Components - External

- | | |
|---|---|
| 1. Steer Control Switch | 7. Machine Tilt Indicator |
| 2. Drive and Lift Joystick Control | 8. Emergency Stop Switch |
| 3. Trigger Switch | 9. Horn Button |
| 4. Forward/Reverse/Lift/Lower Direction Decal | 10. Drive and Lift Select Switch |
| 5. Alarm | 11. Low Battery Charge/System Fault Indicator |
| 6. Overload Indicator (If Equipped) | |

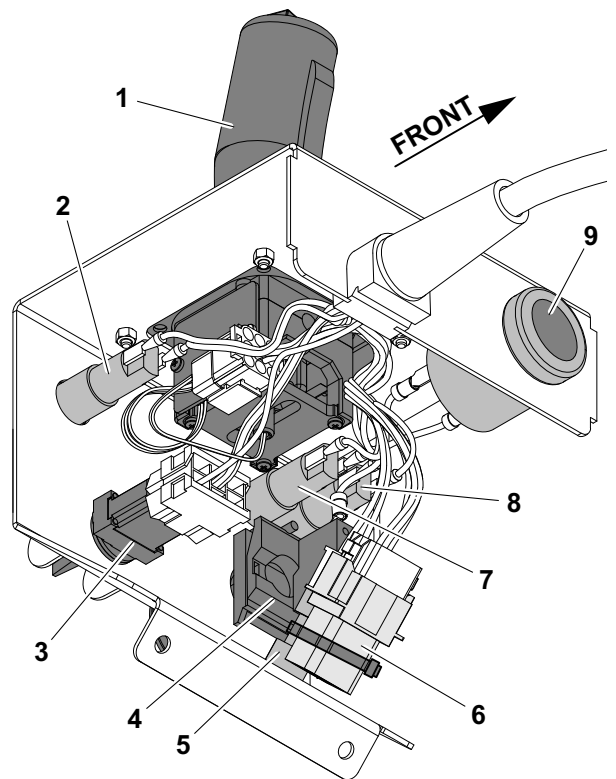

Figure 3-61. Platform Control Station Components - Internal

- | | |
|--|--|
| 1. Drive and Lift Joystick Control | 5. Horn Button Switch |
| 2. Low Battery Charge/System Fault Indicator | 6. Harness Splice Connector ⁽¹⁾ |
| 3. Drive and Lift Select Switch | 7. Machine Tilt Indicator |
| 4. Emergency Stop Switch | 8. Overload Indicator (If Equipped) |
| | 9. Alarm |

NOTE: (1) Zip-tie item-6 (Harness Splice Connector) to item-5 (Horn Button Switch), to prevent any possible interference with the joystick path.

Joystick Controller

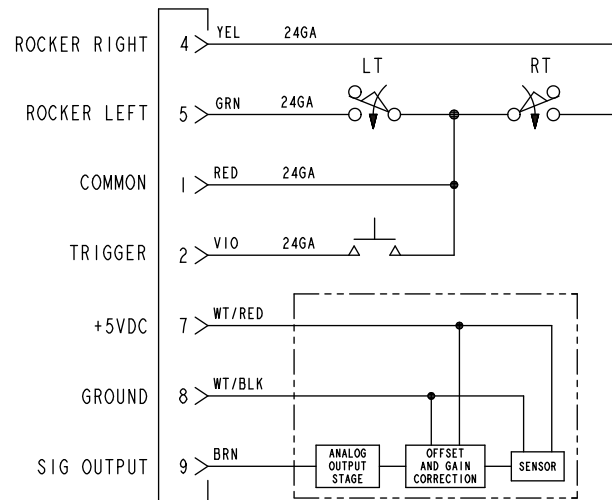
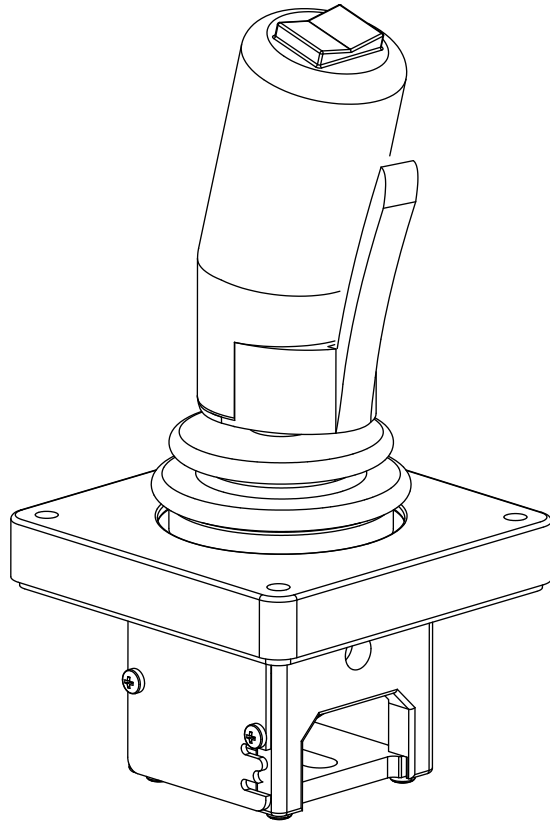

Figure 3-62. Joystick

Table 3-5. Joystick Specifications

Input Voltage	+5 (±0.1) VDC
Current Consumption	10 mA @ 12 VDC
Output: Handle Centered	2.5 (±0.1) VDC
Output: Full Positive (Reverse) Deflection	4 (±0.1) VDC
Output: Full Negative (Forward) Deflection	1 (±0.1) VDC

NOTE: For joystick calibration procedure see *Joystick Calibration* - page 5-5.

Table 3-6. Connector Chart

CONNECTOR PINOUT		
Term	Color	Function
1	RED	HANDLE.COM
2	VIOLET	TRIGGER.N.O.
3	--	SPARE
4	YELLOW	ROCKER.RT
5	GREEN	ROCKER.LT
6	--	SPARE
7	WHITE/RED	+5VDC
8	WHITE/BLACK	GROUND
9	BROWN	SIG OUTPUT

SECTION 4. HYDRAULICS

4.1 CYLINDERS - THEORY OF OPERATION

Cylinders are of the double acting type. The Lift and Steer systems incorporate double acting cylinders. A double acting cylinder is one that requires oil flow to operate the cylinder rod in both directions. Directing oil (by actuating the corresponding control valve to the piston side of the cylinder) forces the piston to travel toward the rod end of the barrel, extending the cylinder rod (piston attached to rod). When the oil flow is stopped, movement of the rod will stop. By directing oil to the rod side of the cylinder, the piston will be forced in the opposite direction and the cylinder rod will retract.

NOTE: *The lift cylinder is a single acting cylinder which takes hydraulic pressure to extend and gravity to retract.*

A holding valve is used in the hydraulic lift circuit to prevent motion unintended by the operator in the event of a hydraulic line failure.

4.2 VALVES - THEORY OF OPERATION

Solenoid Control Valves (Bang-Bang)

Control valves used are four-way, three-position solenoid valves of the sliding spool design. When a circuit is activated and the control valve solenoid energizes, the spool is shifted and the corresponding work port opens to permit oil flow to the component in the selected circuit, with the opposite work port opening to reservoir. Once the circuit is deactivated (control returned to neutral), the valve spool returns to neutral (center) and oil flow is then directed through the valve body and returns to reservoir. A typical control valve consists of the valve body, sliding spool, and two solenoid assemblies. The spool is machine fitted in the bore of the valve body. Lands on the spool divide the bore into various chambers, which, when the spool is shifted, align with corresponding ports in the valve body open to common flow. At the same time other ports would be blocked to flow. The spool is spring-loaded to center position, therefore when the control is released, the spool automatically returns to neutral, prohibiting any flow through the circuit.

Relief Valves

Main relief valves are installed at various points within the hydraulic system to protect associated systems and components against excessive pressure. Excessive pressure can be developed when a cylinder reaches its limit of travel and the flow of pressurized fluid continues from the system control. The relief valve provides an alternate path for the continuing flow from the pump, thus preventing rupture of the cylinder, hydraulic line or fitting. Complete failure of the system pump is also avoided by relieving circuit pressure. The relief valve is installed in the circuit between the pump outlet (pressure line) and the cylinder of the circuit, generally as an integral part of the system valve bank. Relief pressures are set slightly higher than the load requirement, with the valve diverting excess pump delivery back to the reservoir when operating pressure of the component is reached.

Crossover Relief Valves

Crossover relief valves are used in circuits where the actuator requires an operating pressure lower than that supplied to the system. When the circuit is activated and the required pressure at the actuator is developed, the crossover relief diverts excess pump flow to the reservoir. Individual, integral relief's are provided for each side of the circuit.

Proportional Valve

Flow is proportional to the amount of voltage supplied to the valve coil. Voltage is gained by the machine controller and determined by the position of the joystick.

Manual Descent Valve

The manual descent valve is located on the top of the holding valve on the lift cylinder. The holding valve is a normally closed solenoid valve, and holds the platform in place when raised. When activated, the valve opens to permit lift down. The holding valve is connected to the manual descent valve, which is connected to a cable which, when pulled, manually opens the lift down port of the valve and allows the platform to be lowered in the event hydraulic and/or electric power is lost.

4.3 PUMP/MOTOR

Theory of Operation

The Power Module (see Section 3.12, Power Control Module - ZAPI) is essentially a "low-side" switch for the pump motor. The positive terminal of the pump is tied to Battery Positive after the Line Contactor. The negative terminal of the pump connects to the P Terminal of the Power Module, which switches current through MOSFET transistors to the Battery Negative.

For variable speed pump operation, the MOSFET transistors switch On and Off at high frequencies (16kHz). The Duty Cycle is varied to control the voltage applied to the pump motor. When the MOSFET's spend 50% of the period On and 50% Off, approximately ½ of the available Battery Voltage will be applied to the pump motor. Similarly, the MOSFET are On continuously (100% Duty Cycle) to apply all available Battery Voltage to the pump motor (as in Lift Up at full speed).

When the Control System is energized, the voltage at the P Terminal will be approximately +24V (referenced to -B) when the pump is static. The P Terminal will be approximately +1V (referenced to -B) when the pump is running at full speed (Lift Up from Ground Mode).

Pump Motor Electrical Evaluation

Several basic electrical tests can be performed on the Pump Motor. Failure of one of these evaluations is significant and may indicate that the device is physically damaged.

Refer to Figure 7-2., Resistance Measurement. Make all measurements with a voltmeter set to resistance scale (Ohms). Disconnect main power at the batteries and all pump motor cables during this analysis.

- **Resistance < 5 Ohms between Motor Terminals.**
The internal windings are very low impedance and should appear to be a short-circuit for an ordinary voltmeter (other tests can determine if the windings are truly shorted). High resistance can signal worn brushes, a faulty commutator, or open windings.
- **Resistance > 1 Mega-Ohms between Motor Terminals and Motor Housing.** The internal windings should be electrically isolated from the motor housing. Low resistance may be an indication of a broken motor terminal, damaged brush, faulty commutator, or burned winding.

COMMON DIFFICULTIES

The following difficulties can be examined using the JLG Analyzer, a voltmeter, and simple hand tools. Unless otherwise noted, the Control System shall be energized in Ground Mode during testing. For a convenient Ground Reference, place the black meter lead on the negative post of the left battery in the left-side batter compartment. The vehicle should be placed on a smooth, firm, and level surface for all analysis.

1. Open-Circuit between +B Terminal and Pump Motor Positive Terminal

This issue will allow the vehicle to drive, but Lift Up and Steer Functionality will be lost and the Pump Motor will not operate. Under DIAGNOSTICS - PUMP, the JLG Analyzer will show PUMP PWM 100% and PUMP CUR 0.0A when Lift Up is operated from Ground Mode.

As shown in the diagram, the voltage measured between the Pump Motor Positive Terminal and Ground Reference should be 24V. If it is not, examine the cable between the terminal and the Power Module compartment. Inspect crimps for corrosion and ensure that bolted connections are tight. Ensure that the cable is not crushed where it passes between the frame side sheets and the cylinder assembly.

2. Open-Circuit between Pump Motor Negative Terminal and P Terminal

This issue will allow the vehicle to drive, but Lift Up and Steer Functionality will be lost and the Pump Motor will not operate. Under DIAGNOSTICS - PUMP, the JLG Analyzer will show PUMP PWM 100% and PUMP CUR 0.0A when Lift Up is operated from Ground Mode.

After ensuring there is not an Open-Circuit between the +B Terminal and Pump Motor Positive Terminal, check that the voltage measured between the Pump Motor Negative Terminal and Ground Reference is 24V. If not, examine the issues within Open-Circuit Pump Motor. This voltage should ramp to approximately 0V when Lift Up is operated from Ground Mode. If not, examine the cable between the terminal and the Power Module compartment (P Terminal). Inspect crimps for corrosion and ensure that bolted connections are tight. Ensure that the cable is not crushed where it passes between the frame side sheets and the cylinder assembly.

3. Open-Circuit Pump Motor

This issue will allow the vehicle to drive, but Lift Up and Steer Functionality will be lost and the Pump Motor will not operate. Under DIAGNOSTICS - PUMP, the JLG Analyzer will show PUMP PWM 100% and PUMP CUR 0.0A when Lift Up is operated from Ground Mode.

Disconnect main power at the batteries to completely de-energize the Control System. Next, detach the cable from Pump Motor Positive Terminal. Using a voltmeter set for resistance measurement (Ohms), ensure that the resistance between the Pump Motor Positive and Negative Terminals is less than 2 Ohms. If not, examine the pump motor for worn brushes or broken terminals. After examination, re-connect the Pump Motor Positive Terminal and main power at the batteries.

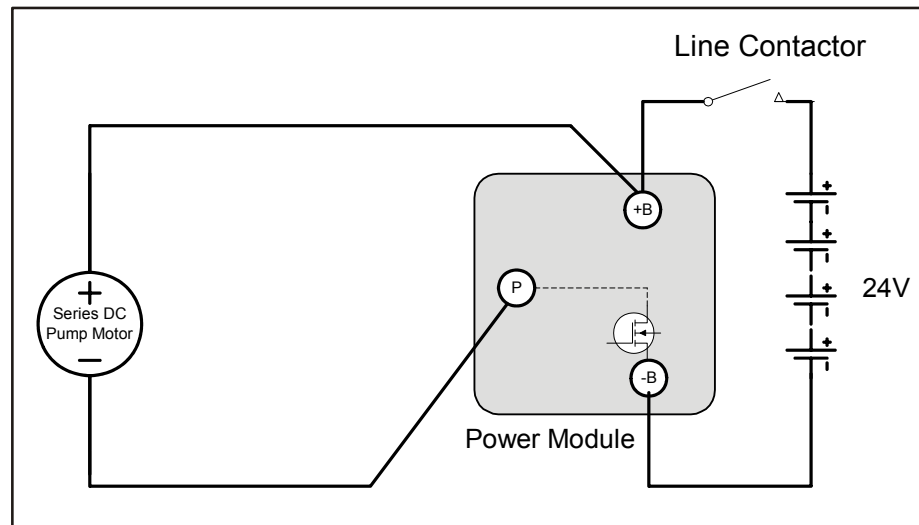

4. Short-Circuit between Pump Motor Positive and Negative Terminals

This issue will allow the vehicle to drive, but Lift Up and Steer Functionality will be lost and the Pump Motor will not operate. Under DIAGNOSTICS - PUMP, the JLG Analyzer will show an erratic reading for PUMP PWM % and PUMP CUR will hover around 150A when Lift Up is operated from Ground Mode.

Disconnect main power at the batteries to completely de-energize the Control System. Next, detach both Pump Motor Terminals and insulate them independently. Re-connect main power at the batteries and retry Lift Up. If the same symptoms persist (erratic PUMP PWM%, PUMP CUR around 150A), examine the cabling between the Pump Motor and Power Module compartment for a short-circuit (most likely near area where cylinder retracts between frame side sheets or near pot-hole mechanism, if equipped). If the symptoms change, suspect a short-circuited (or mechanically frozen) pump motor.

A clamp-on ammeter (set for 200A DC) can be placed on either Pump Motor Cable for verification. During Lift Up, the ammeter will read approximately 150A.

Hydraulic Oil Check Procedure

Lube Point(s) - Hydraulic Reservoir

Lube - Hydraulic Oil

Interval - Check Daily

Table 4-1. Hydraulic System Capacities

COMPONENT	1932RS/6RS	3248RS/10RS
Hydraulic Tank	1.32 Gal. (5L)	2.38 Gal. (9L)
Hydraulic System	1.85 Gal. (7L)	3.96 Gal. (15L)

NOTE: Check the hydraulic oil level with the platform in the stowed position *ONLY*. Be certain the hydraulic oil has warmed to operating temperature before checking the oil level in the reservoir.

1. On the left side of the machine, remove the side access door on the base frame. Locate the hydraulic oil reservoir (1) on the pump unit (2). Check the oil level in the hydraulic reservoir by looking at the markings on the side of the tank. The reservoir is marked with a MAX (maximum) marking (3). The oil level must be kept at or within one (1) inch of this marking to operate properly.
2. If additional oil is required, wipe all dirt and debris from the **filler/breather cap (4)** area, add proper grade of oil. Fill until oil level is close to the **MAX marking (3)**, but not over the **MAX marking**.

NOTE: Care should be taken not to introduce any impurities (dirt, water, etc.) while cap is removed.

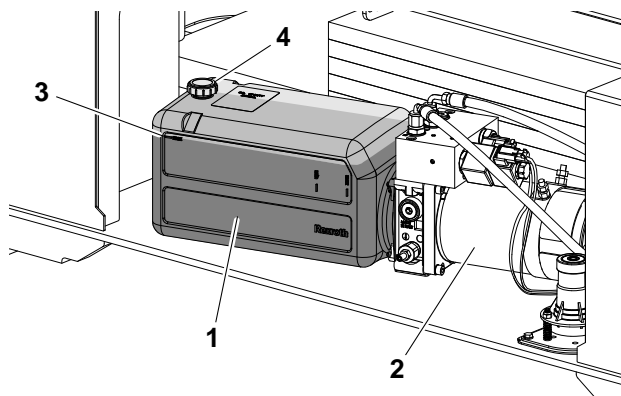

Figure 4-1. Hydraulic Oil Check Procedure - All Machines

NOTE: Recommended lubricating intervals are based on machine operations under normal conditions. For machines used in multi-shift operations and/or exposed to hostile environments or conditions, lubrication frequencies must be increased accordingly.

Pump/Tank Disassembly

(See Figure 4-2.)

1. Place the pump/motor assembly on a clean workbench.

NOTE: Drain the hydraulic oil by carefully removing the oil fill plug located on the hydraulic reservoir and tilting the assembly up allowing oil to drain into a clean container.

2. Remove the oil tank from the pump as follows:
 - a. Slowly loosen and remove the four bolts that hold the tank to valve body attachment ring on to the valve body.
 - b. Carefully remove the tank from the valve taking care not to damage internal pickup tube or o-ring gasket on tank.
 - c. Place tank on a suitable work bench or work area.

NOTE: The filter and bypass are located on the pickup tube inside the tank. The filter should be changed once a year.

3. If replacing filter, pull old filter off the end of the tube and push new filter onto the end of tube.
 - a. Thoroughly clean the tank and clean any debris from the magnet.
 - b. Wipe out tank with clean, lint free rag, taking care not to introduce debris or dirt.
 - c. Replace the tank. Torque mounting bolts to 6-7 ft-lb. (8.5-10 Nm).
 - d. If only replacing the oil filter and maintenance is complete, reinstall tank assembly on machine, remove fill cap and refill tank with proper grade of

oil by using a funnel. Fill until oil is up to the MAX level indicator on the side of the tank.

4. To remove the oil pickup line, squeeze retainer and slide outward.

NOTE: There are two o-rings located in the valve for the pump outlet.

5. Replace the o-rings if necessary.
6. Remove allen nut on the return/filter line and rotate large retainer ring to remove return/filter line.
7. With the return line and the pickup tube removed, the pump can be removed.
8. Loosen and remove the two hexhead nuts from the pump and block.

NOTE: Be sure to remove and discard the plastic plug at the oil inlet on the new pump before installing.

9. Check o-ring on valve block and replace if necessary before installing the new pump.

NOTICE

NOTE TORQUE VALUES IN FIGURE 4-2. FOR THE VARIOUS FASTENERS AND VALVES INSTALLED ON THE VALVE BODY. DO NOT OVERTIGHTEN OR DAMAGE COULD OCCUR.

Pump Motor Removal

1. Remove the four bolts attaching the motor to the valve adapter assembly.
2. Pull motor from valve.
3. Once all maintenance is performed, reinstall tank assembly on machine, remove fill cap and refill tank with proper grade of oil by using a funnel. Fill until oil is up to the MAX level indicator on the side of the tank.

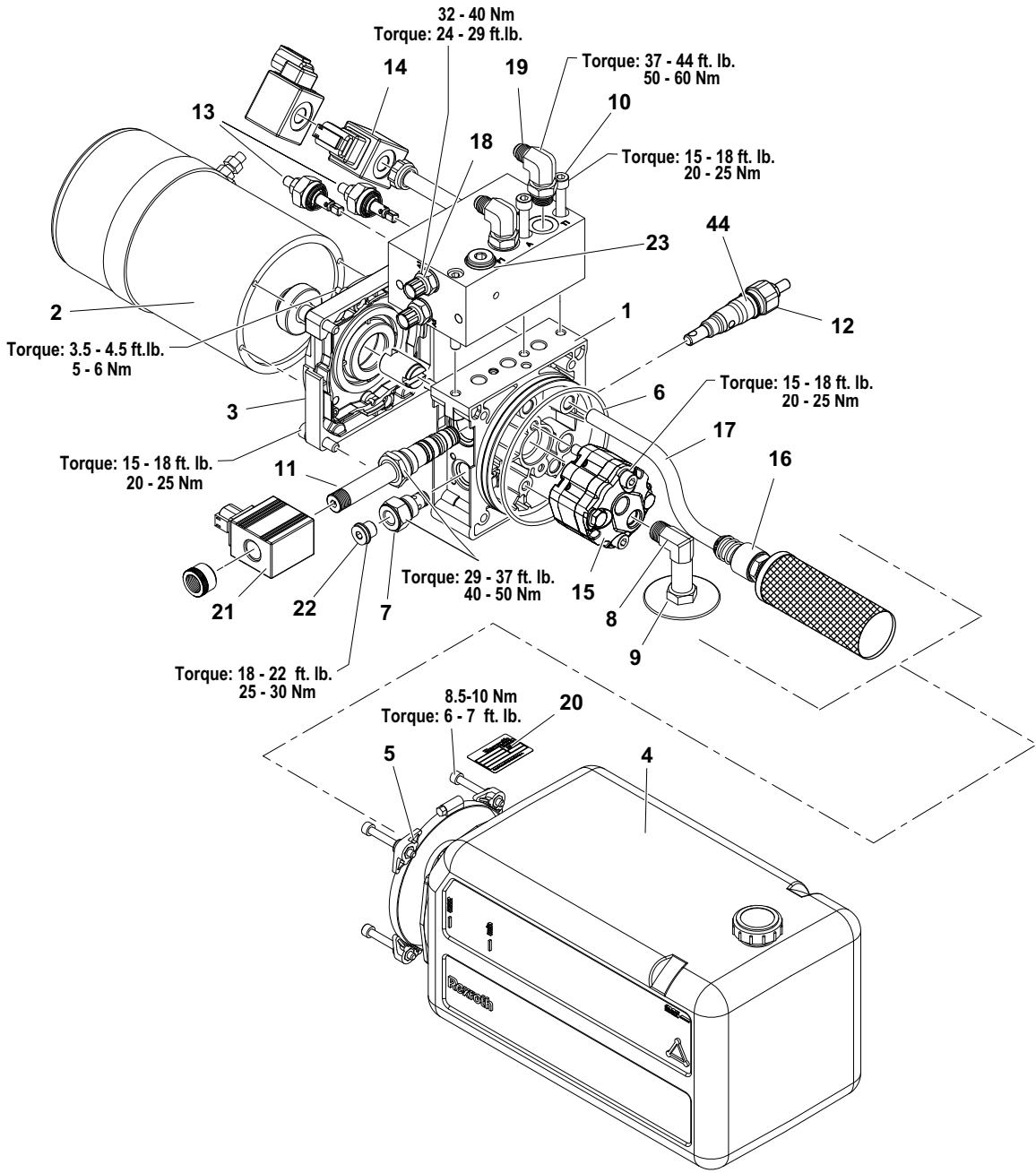

Figure 4-2. Hydraulic Motor, Pump and Tank Assembly (All Machines)

- | | | |
|---------------------------------------|--------------------------------------|---------------------------------|
| 1. Main Valve Body | 9. Suction Filter | 17. Return Filter Pipe |
| 2. Pump Electric Motor | 10. Modular to Main Valve Body Screw | 18. 1/4" JIC/BSPP Adapter |
| 3. Motor to Valve Body Adapter | 11. Solenoid Valve | 19. 3/8" JIC/BSPP - 90° Adapter |
| 4. Hydraulic Oil Tank | 12. Lift Relief Valve | 20. Product ID Plate |
| 5. Tank to Valve Body Attachment Ring | 13. Steer Relief Valves | 21. Valve Coil for Lift Up/Down |
| 6. Tank to Valve Body - O-Ring | 14. Valve Coil for Steer Cylinder | 22. M Port - 1/4" BSPP |
| 7. Auxiliary Pressure (M) Port | 15. Gear Pump | 23. P1 Port - 3/8" BSPP |
| 8. Suction Pipe | 16. Return Filter w/Bypass | |

4.4 LIFT PRESSURE SETTING PROCEDURE

1. Place 120% of the rated load of the machine on the platform.
2. Increase lift pressure to raise the platform to full height.
3. Adjust the pressure setting screw on lift relief valve to reach the proper lift pressure per model as listed in Table 4-2.

Table 4-2. Lift Pressure Settings

Model	Lift Relief	Steer Relief
1932RS/6RS	2300 psi ± 50 psi (159 bar ± 3.5 bar)	1000 psi (69 bar)
3248RS/10RS	2500 psi ± 50 psi (172 bar ± 3.5 bar)	1000 psi (69 bar)

**Alternate Lift Pressure Setting Procedure -
(if 120% load or high ceiling is not available):**

1. Install adapter from table into M-port or P1-port on pump (see Figure 4-2.) and attach pressure gauge.

Table 4-3. Pressure Fitting Adapter

PORT	JLG PART #
P1	300057 - JIC
M	300017 - JIC
	2221222 - Quick Disconnect

2. Remove the solenoid from the lift valve.
3. Activate the lift function from the ground or platform and adjust the pressure setting screw on lift relief valve to reach the proper lift pressure per model as listed in Table 4-2.
4. Remove the pressure gauge from port M or P1 and replace plug.
5. Replace the solenoid on the lift valve.

4.5 CYLINDER CHECKING PROCEDURE

NOTE: Cylinder check must be performed anytime a system component is replaced or when improper system operation is suspected.

1. Using all applicable safety precautions, activate pump motor and fully extend cylinder to be checked.
2. Carefully disconnect hydraulic hoses from retract port of cylinder. There will be some initial weeping of hydraulic fluid which can be caught in a suitable container. After the initial discharge, there should be no further drainage from the retract port.
3. Activate pump motor and extend cylinder.
4. If cylinder retract port leakage is less than 6-8 drops per minute, carefully reconnect hose to port and retract cylinder. If leakage continues at a rate of 6-8 drops per minute or more, cylinder repair must be made.

NOTE: Steps 5 through 7 for Steer Cylinder Only.

5. With cylinder fully retracted, shut down machine power and carefully disconnect hydraulic hose from cylinder extend port.
6. Activate pump motor and retract cylinder. Check extend port for leakage.
7. If extend port leakage is less than 6-8 drops per minute, carefully reconnect hose to extend port, than activate cylinder through one complete cycle and check for leaks. If leakage continues at a rate of 6-8 drops per minute or more, cylinder repairs must be made.

4.6 LIFT CYLINDER REMOVAL

NOTE: *If there is a pump failure, a crane or a forktruck can be used to raise the platform. Refer to Figure 3.15, Scissor Arms Removal.*

Self locking fasteners, such as nylon insert and thread deforming locknuts, are not intended to be reinstalled after removal. Always use new replacement hardware when installing locking fasteners.

1. Raise the platform and use an overhead crane or fork truck to secure the platform and scissor arms before lift cylinder removal begins. (See Figure 3-42.)
2. Cut any wire ties that attach any cables or hoses to the lift cylinder.

NOTICE

DISCONNECT MAIN POWER FROM THE BATTERIES BEFORE REMOVING ANY COMPONENTS FROM THE LIFT CYLINDER ASSEMBLY.

3. Remove the valve connector, the two hoses and the manual decent cable from the cylinder.

NOTE: *To avoid having to readjust the manual descent, remove the large nut located behind the manual descent bracket as shown.*

Also see Figures 3-43., 3-44., 3-45., for lift cylinder mounting hardware configurations.

4. Ensuring that the deck and scissor arms are properly secure, remove the top lift cylinder pin and rest the top of the cylinder on the arm cross tube directly below the cylinder.
5. Remove the bolt from the lower cylinder pin and have someone assist you in lifting the cylinder from the scissor arms.
6. Place the cylinder on a clean workbench.

4.7 CYLINDER REPAIR

NOTE: The following are general procedures that apply to the cylinders on this machine. Procedures that apply to a specific cylinder will be so noted.

Disassembly

NOTICE

DISASSEMBLY OF THE CYLINDER SHOULD BE PERFORMED ON A CLEAN WORK SURFACE IN A DIRT FREE WORK AREA.

1. Connect a suitable auxiliary hydraulic power source to the port block fitting in the manifold located on the cylinder.

WARNING

DO NOT FULLY EXTEND CYLINDER TO THE END OF STROKE. RETRACT CYLINDER SLIGHTLY TO AVOID TRAPPING PRESSURE.

2. Operate the hydraulic power source and extend the cylinder. Shut down and disconnect the power source. Adequately support the cylinder rod, if applicable.
3. If applicable, remove the cartridge-type holding valve and fittings from the cylinder port block. Discard o-rings.
4. Place the cylinder barrel into a suitable holding fixture.

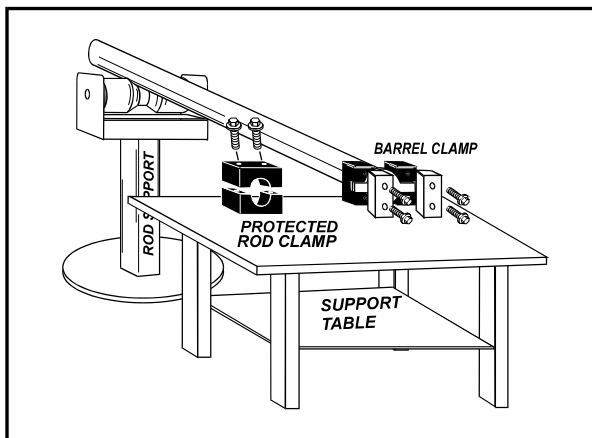

Figure 4-3. Cylinder Barrel Support

5. Mark cylinder head and barrel with a center punch for easy realignment. Loosen the cylinder head setscrew.
6. Using the proper wrench, loosen the cylinder head and remove head from cylinder barrel. When removing cylinder head do not force if binding occurs. Reverse rotation a couple times and try removing again. If still no release, tap barrel with hammer in threaded area, and try again. Repeat if necessary, until head is completely removed.

7. Attach a suitable pulling device to the cylinder rod port block end or cylinder rod end, as applicable.

NOTICE

EXTREME CARE SHOULD BE TAKEN WHEN REMOVING THE CYLINDER ROD, HEAD, AND PISTON. AVOID PULLING THE ROD OFF-CENTER, WHICH COULD CAUSE DAMAGE TO THE PISTON AND CYLINDER BARREL SURFACES.

8. With the barrel clamped securely, apply pressure to the rod pulling device and carefully withdraw the complete rod assembly from the cylinder barrel.

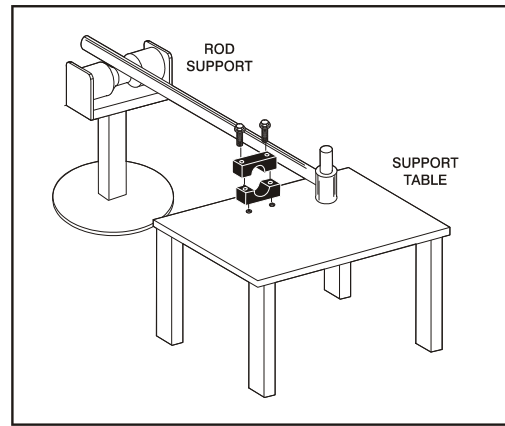

Figure 4-4. Cylinder Rod Support

9. Using suitable protection, clamp the cylinder rod in a vise or similar holding fixture as close to the piston as possible.

NOTE: For steer cylinder piston removal, see Steer Cylinder Piston Removal on page 4-9 following.

10. Loosen and remove the cap screw(s), if applicable, which attach the tapered bushing to the piston.
11. Insert the cap screw(s) in the threaded holes in the outer piece of the tapered bushing. Progressively tighten the cap screw(s) until the bushing is loose on the piston.
12. Remove the bushing from the piston.
13. Screw the piston CCW, by hand, and remove the piston from cylinder rod.
14. Remove and discard the piston o-rings, seal rings, and backup rings.
15. If applicable, remove the piston spacer from the rod.
16. Remove the rod from the holding fixture. Remove the cylinder head gland and retainer plate, if applicable. Discard the o-rings, back-up rings, rod seals, and wiper seals.

Steer Cylinder Piston Removal

1. Using the spanner holes, rotate the piston until the end of the retaining ring can be seen through the cross-drilled retaining ring hole.
2. Insert a flathead screwdriver (or similar tool) into the cross-drilled retaining ring hole.
3. Using the screwdriver, guide the retaining ring into the cross-drilled retaining ring hole while turning the piston.
4. Continue turning the piston approximately one (1) full turn until the start of the retaining ring is again aligned with the cross-drilled retaining ring hole.
5. Lift up on the retaining ring so that the hook on the start of the retaining ring releases from the hole in the rod.
6. Pull the retaining ring all the way out of the cross-drilled retaining ring hole.
7. Slide the piston over the rod in the direction of the spanner holes to remove.

Cleaning and Inspection

1. Clean all parts thoroughly in an approved cleaning solvent.
2. Inspect the cylinder rod for scoring, tapering, ovality, or other damage. If necessary, dress rod with Scotch Brite or equivalent. Replace rod if necessary.
3. Inspect threaded portion of rod for excessive damage. Dress threads as necessary.
4. Inspect inner surface of cylinder barrel tube for scoring or other damage. Check inside diameter for tapering or ovality. Replace if necessary.
5. Inspect threaded portion of barrel for damage. Dress threads as necessary.
6. Inspect piston surface for damage and scoring and for distortion. Dress piston surface or replace piston as necessary.
7. Inspect threaded portion of piston for damage. Dress threads as necessary.
8. Inspect seal and o-ring grooves in piston for burrs and sharp edges. Dress applicable surfaces as necessary.
9. Inspect cylinder head inside diameter for scoring or other damage and for ovality and tapering. Replace as necessary.

10. Inspect threaded portion of head for damage. Dress threads as necessary.
11. Inspect seal and o-ring grooves in head for burrs and sharp edges. Dress applicable surfaces as necessary.
12. Inspect cylinder head outside diameter for scoring or other damage and ovality and tapering. Replace as necessary.
13. If applicable, inspect rod and barrel bearings for signs of correct excessive wear or damage. Replace as necessary.
 - a. Thoroughly clean hole, (steel bushing) of burrs, dirt etc. to facilitate bearing installation.
 - b. Inspect steel bushing for wear or other damage. If steel bushing is worn or damaged, rod/barrel must be replaced.
 - c. Lubricate inside of steel bushing with WD40 prior to bearing installation.
 - d. Using an arbor of the correct size, carefully press the bearing into steel bushing.

NOTE: Install pin into the Gar-Max bearing dry. Lubrication is not required with nickel plated pins and bearings.

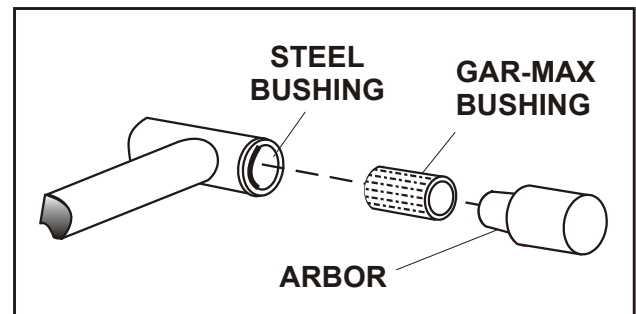

Figure 4-5. Gar-Max Bearing Installation

14. Inspect travel limiting collar or spacer for burrs and sharp edges. If necessary, dress inside diameter surface with Scotch Brite or equivalent.
15. If applicable, inspect port block fittings and holding valve. Replace as necessary.
16. Inspect the oil ports for blockage or the presence of dirt or other foreign material. Repair as necessary.
17. If applicable, inspect piston rings for cracks or other damage. Replace as necessary.

Assembly

NOTE: Prior to cylinder assembly, ensure that the proper cylinder seal kit is used. See your JLG Parts Manual for these machine models.

Apply a light film of hydraulic oil to all components prior to assembly.

1. A special tool is used to install a new rod seal into the applicable cylinder head gland groove.

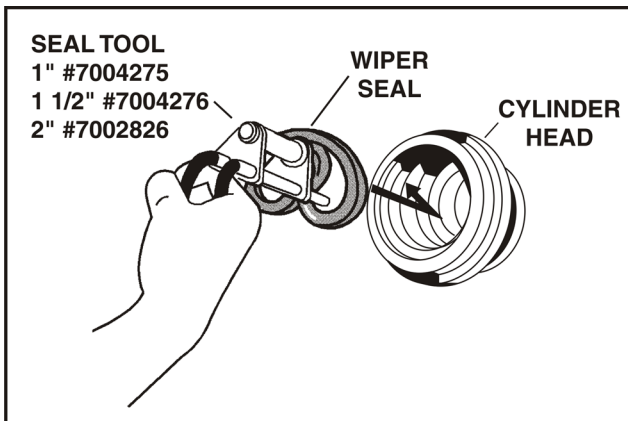

Figure 4-6. Rod Seal Installation

NOTICE

WHEN INSTALLING 'POLY-PAK' PISTON SEALS, ENSURE SEALS ARE INSTALLED PROPERLY. REFER TO WIPER SEAL INSTALLATION FOR CORRECT SEAL ORIENTATION. IMPROPER SEAL INSTALLATION COULD RESULT IN CYLINDER LEAKAGE AND IMPROPER CYLINDER OPERATION.

2. Use a soft mallet to tap a new wiper seal into the applicable cylinder head gland groove. Install a new wear ring into the applicable cylinder head gland-groove.

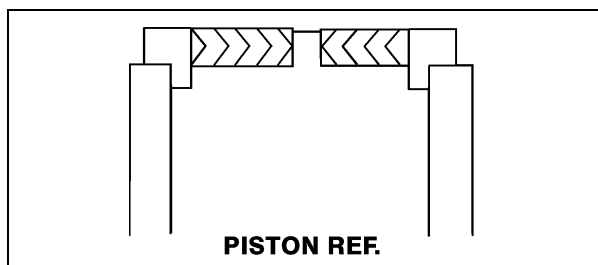

Figure 4-7. Poly-Pak Piston Seal Installation

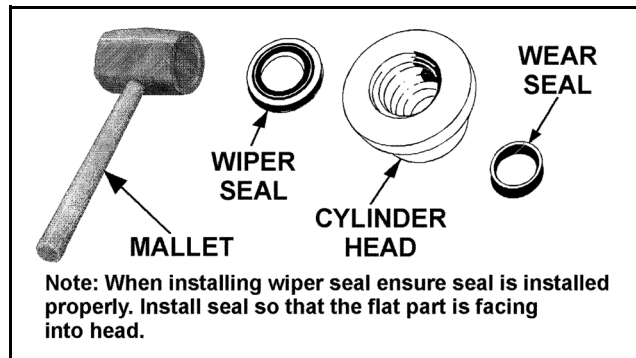

Figure 4-8. Wiper Seal Installation

3. Place a new "O-ring and back-up seal in the applicable outside diameter groove of the cylinder head.

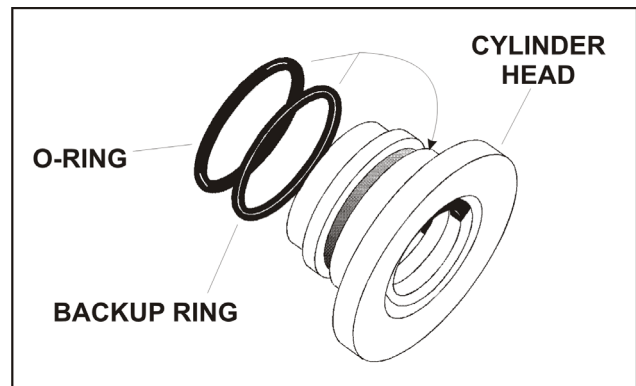

Figure 4-9. Installation of Head Seal Kit

4. Install washer ring onto rod, carefully install the head gland on the rod, ensuring that the wiper and rod seals are not damaged or dislodged. Push the head along the rod to the rod end, as applicable.
5. If applicable, correctly place new o-ring in the inner piston diameter groove. (The backup ring side facing the O-ring is grooved.)
6. If applicable, correctly place new seals and guide lock rings in the outer piston diameter groove. (A tube, with I.D. slightly larger than the O.D. of the piston is recommended to install the solid seal.)

NOTE: The backup rings for the solid seal have a radius on one side. This side faces the solid seal. (See magnified insert in Figure 4-9. The split of seals and backup rings are to be positioned so as not to be in alignment with each other.)

7. Using suitable protection, clamp the cylinder rod in a vise or similar holding fixture as close to piston as possible.

8. Carefully thread the piston on the cylinder rod hand tight, ensuring that the o-ring and back-up rings are not damaged or dislodged.
9. Thread the piston onto the rod until it abuts the spacer end and install the tapered bushing.

NOTE: When installing the tapered bushing, piston and mating end of rod must be free of oil.

10. Assemble the tapered bushing loosely into the piston and insert JLG capscrews (not vendor capscrews) through the drilled holes in the bushing and into the tapped holes in the piston.
11. Tighten the capscrews evenly and progressively in rotation to the specified torque value.
12. After the screws have been torqued, tap the tapered bushing with a hammer (16 to 24 oz.) and brass shaft (approximately 3/4" in diameter) as follows;
 - a. Place the shaft against the cylinder rod and in contact with the bushing in the spaces between the capscrews.
 - b. Tap each space once; this means the tapered bushing is tapped 3 times as there are 3 spaces between the capscrews.
13. Retorque the capscrews evenly and progressively in rotation to the specified torque value.
14. Remove the cylinder rod from the holding fixture.
15. Place new guide locks and seals in the applicable outside diameter grooves of the cylinder piston.
16. Position the cylinder barrel in a suitable holding fixture.

NOTICE

EXTREME CARE SHOULD BE TAKEN WHEN INSTALLING THE CYLINDER ROD, HEAD, AND PISTON. AVOID PULLING THE ROD OFF-CENTER, WHICH COULD CAUSE DAMAGE TO THE PISTON AND CYLINDER BARREL SURFACES.

17. With the barrel clamped securely, and while adequately supporting the rod, insert the piston end into the barrel cylinder. Ensure that the piston loading o-ring and seal ring are not damaged or dislodged.
18. Continue pushing the rod into the barrel until the cylinder head gland can be inserted into the barrel cylinder.

19. Secure the cylinder head gland using the washer ring and socket head bolts.

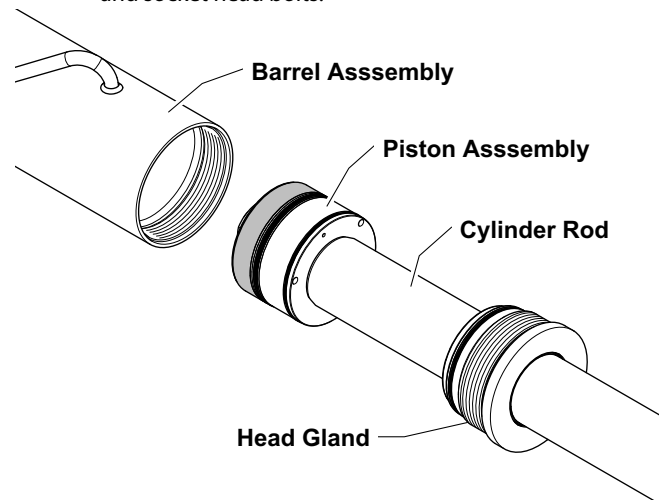

Figure 4-10. Rod Assembly Installation

20. After the cylinder has been reassembled, the rod should be pushed all the way in (fully retracted) prior to the reinstallation of any holding valve or valves.
21. If applicable, install the cartridge-type holding valve and fittings in the rod port block, using new o-rings as applicable. (See Figure 4-13., 1932RS/6RS - Lift Cylinder or Figure 4-14., 3248RS/10RS - Lift Cylinder).
22. Push the piston onto the rod until it abuts the spacer end and install the attaching nut.

WARNING

WHEN REBUILDING THE CYLINDERS, APPLY LOCTITE #262 TO THE PISTON NUT, THEN TORQUE PISTON NUT. REFER TO APPLICABLE CYLINDER ILLUSTRATION FOR TORQUE REQUIREMENT.

NOTE: Reverse the procedure Steer Cylinder Piston Removal on page 4-9 for installing the steer cylinder piston.

23. Remove the cylinder rod from the holding fixture.
24. Position the cylinder barrel in a suitable holding fixture.

NOTICE

EXTREME CARE SHOULD BE TAKEN WHEN INSTALLING THE CYLINDER ROD, HEAD, AND PISTON. AVOID PULLING THE ROD OFF-CENTER, WHICH COULD CAUSE DAMAGE TO THE PISTON AND CYLINDER BARREL SURFACES.

25. With barrel clamped securely, and while adequately supporting the rod, insert the piston end into the barrel cylinder. Ensure that the piston loading o-ring and seal ring are not damaged or dislodged.
26. Continue pushing the rod into the barrel until the cylinder head gland can be inserted into the barrel cylinder.
27. If applicable, secure the cylinder head retainer using a suitable chain wrench.
28. After the cylinder has been reassembled, the rod should be pushed all the way in (fully retracted) prior to the reinstallation of any holding valve or valves.
29. If applicable, install the cartridge-type holding valve and fittings in the port block using new o-rings as applicable. Refer to Figure 4-13., 1932RS/6RS - Lift Cylinder on page 4-13. or Figure 4-14., 3248RS/10RS - Lift Cylinder on page 4-14

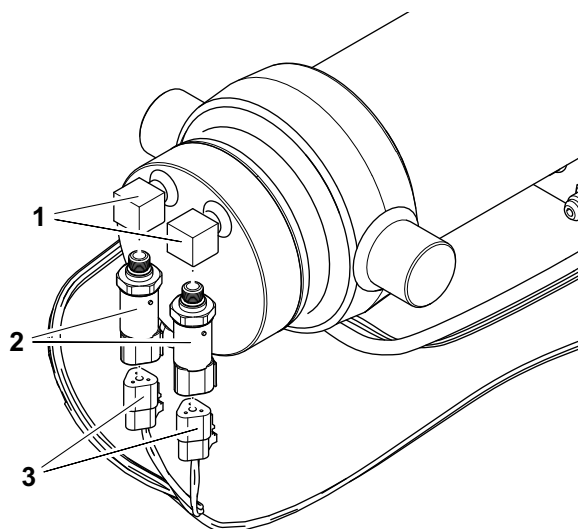

Figure 4-12. LSS Pressure Sensors Location - 3248RS/10RS - (If Equipped)

- | | |
|--------------------------------|-----------------------|
| 1. Ports On Bottom of Cylinder | 3. Harness Connectors |
| 2. Pressure Sensors | |

Lift Cylinder - LSS Pressure Sensor Location (If equipped)

Lift cylinders on machines with the Load Sensing System (LSS) are equipped with two pressure sensing transducers installed. These sensors, two are used in case one should fail, are wired in parallel directly to the machine control module as part of the LSS system.

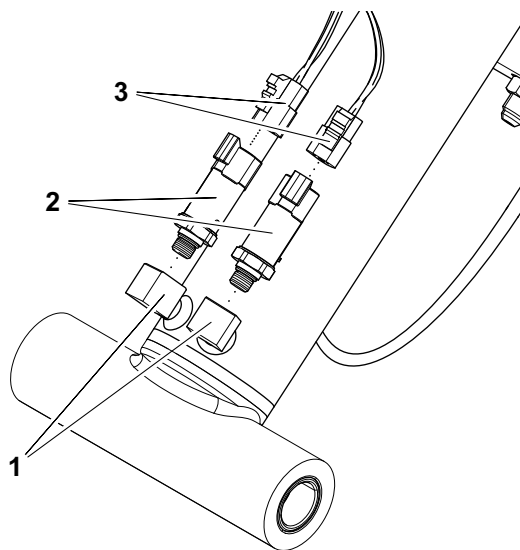
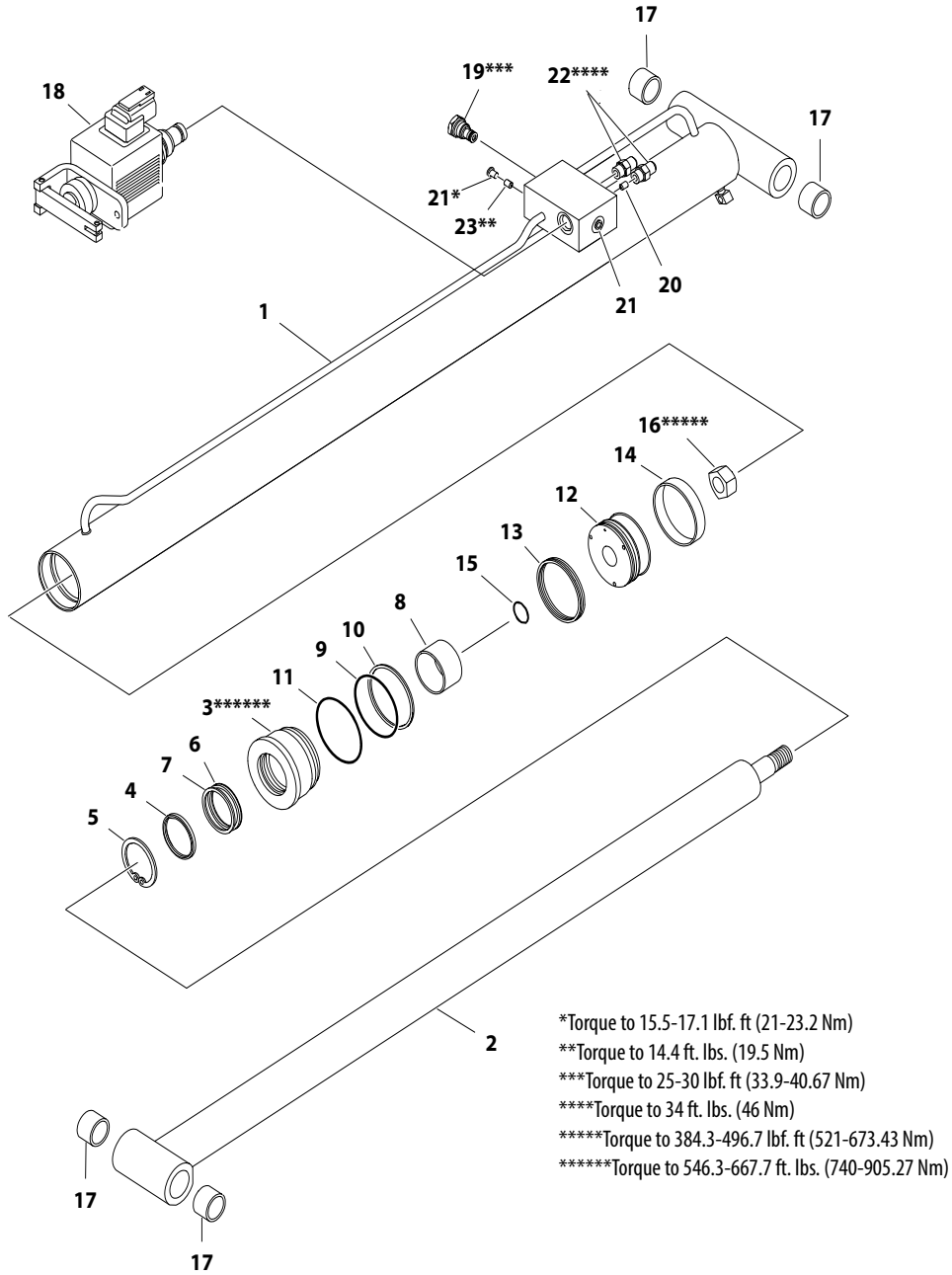

Figure 4-11. LSS Pressure Sensors Location - 1932RS/6RS - (If Equipped)

- | | |
|--------------------------------|-----------------------|
| 1. Ports On Barrel of Cylinder | 3. Harness Connectors |
| 2. Pressure Sensors | |



MAF02480

Figure 4-13. 1932RS/6RS - Lift Cylinder

- | | | |
|--------------------|------------------|---------------------|
| 1. Cylinder Barrel | 9. O-Ring | 17. Bushing |
| 2. Cylinder Rod | 10. Back-up Ring | 18. Cartridge Valve |
| 3. Cylinder Head | 11. O-Ring | 19. Check Valve |
| 4. Wiper | 12. Piston | 20. Orifice |
| 5. Retaining ring | 13. Seal | 21. Plug |
| 6. Seal | 14. Wear Ring | 22. Fitting |
| 7. Back-up Ring | 15. Ring | 23. Orifice |
| 8. Bearing | 16. Piston Nut | |

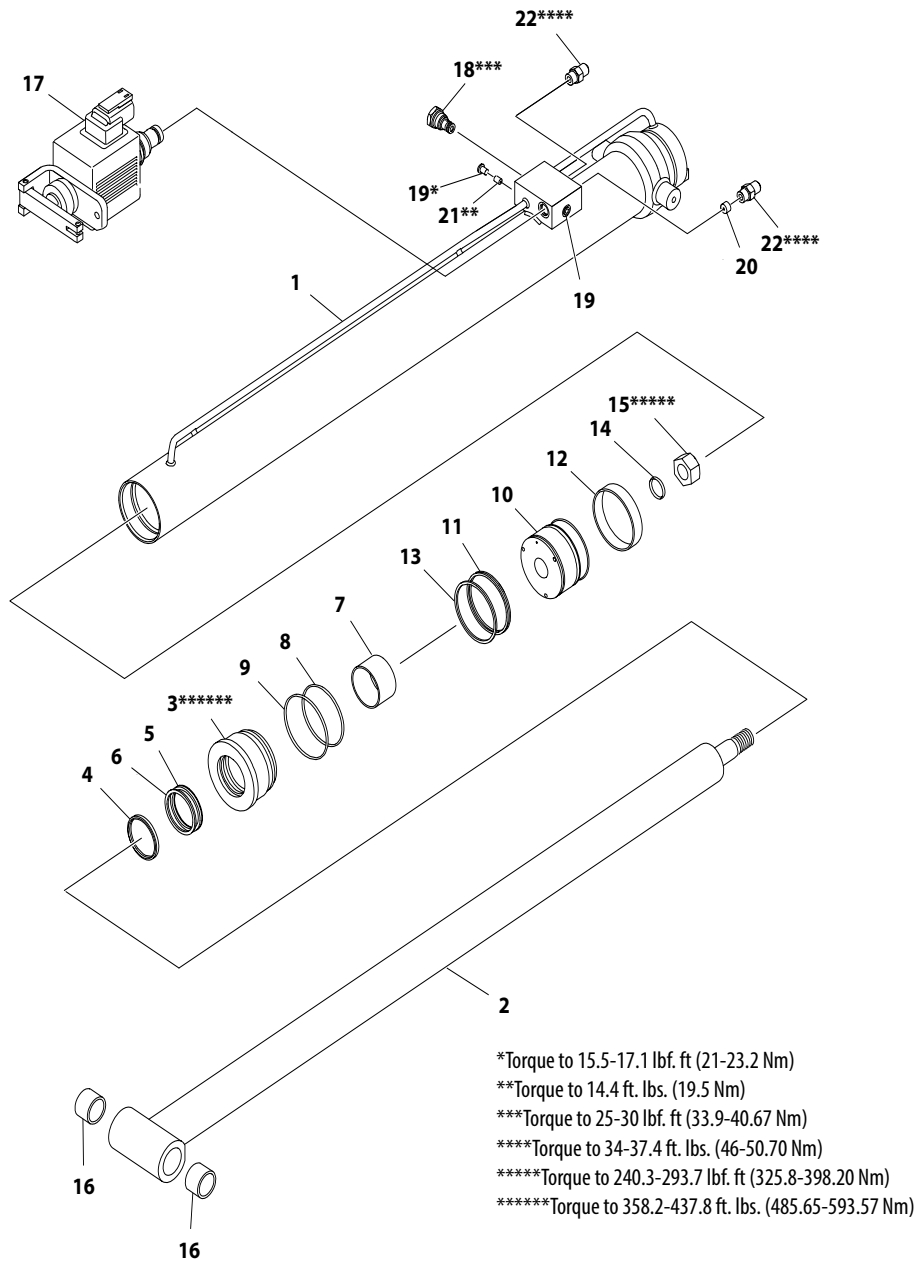

MAF02490

Figure 4-14. 3248RS/10RS - Lift Cylinder

- | | | |
|--------------------|-----------------|---------------------|
| 1. Cylinder Barrel | 8. O-Ring | 16. Bushing |
| 2. Cylinder Rod | 9. O-Ring | 17. Cartridge Valve |
| 3. Cylinder Head | 10. Piston | 18. Cartridge Valve |
| 4. Wiper | 11. Seal | 19. Plug |
| 5. Seal | 12. Wear Ring | 20. Orifice |
| 6. Back-up Ring | 13. Piston Ring | 21. Orifice |
| 7. Bearing | 14. O-Ring | 22. Fitting |
| | 15. Piston Nut | |

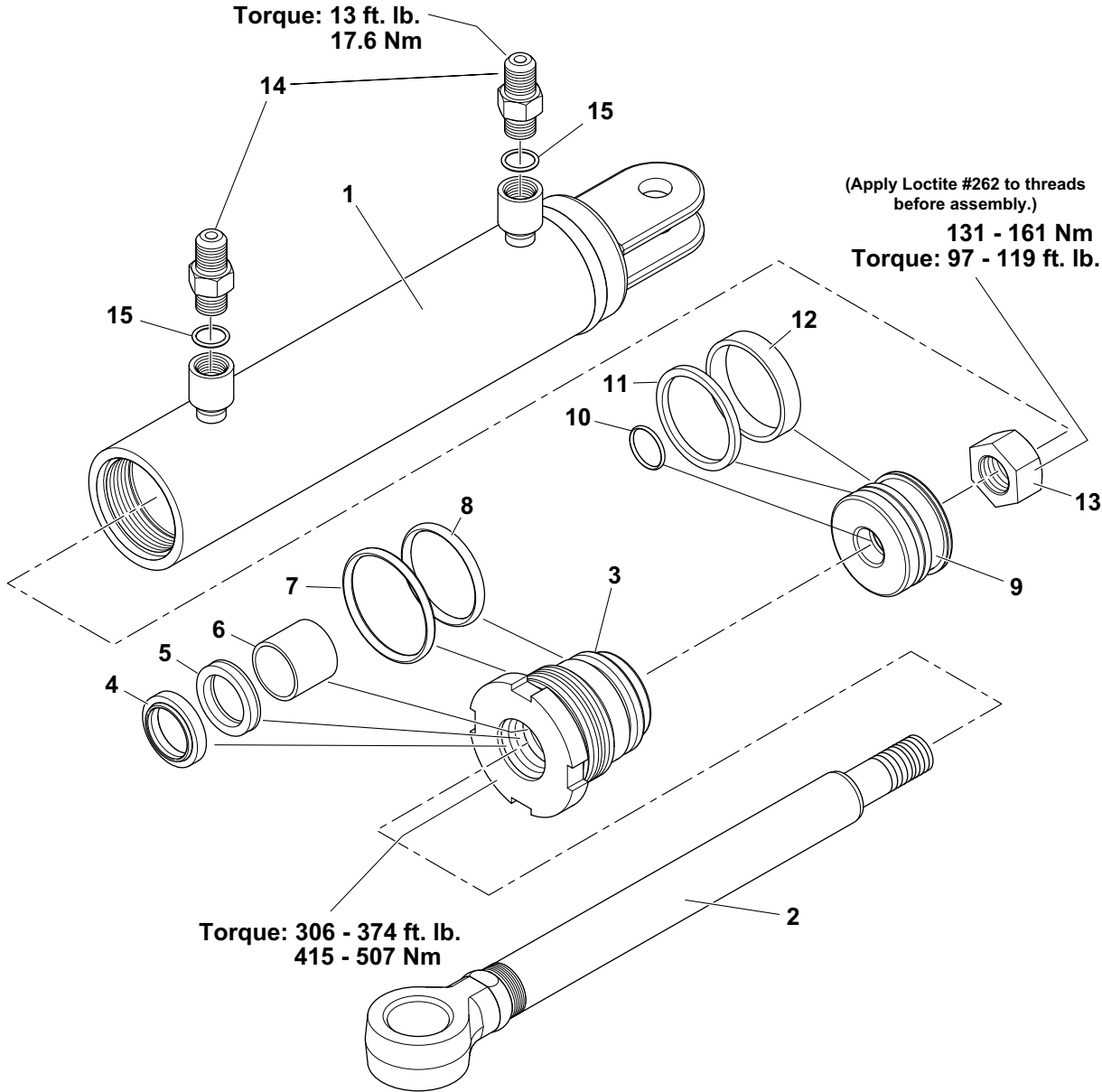

Figure 4-15. 1932RS/6RS - Steer Cylinder

- | | | |
|--------------------|----------------|-------------------|
| 1. Cylinder Barrel | 6. Wear Ring | 11. Piston Seal |
| 2. Cylinder Rod | 7. O-Ring | 12. Wear Ring |
| 3. Head | 8. O-Ring | 13. Nut |
| 4. Wiper Seal | 9. Piston | 14. Hose Fittings |
| 5. Rod Seal | 10. Rod O-Ring | 15. O-Ring |

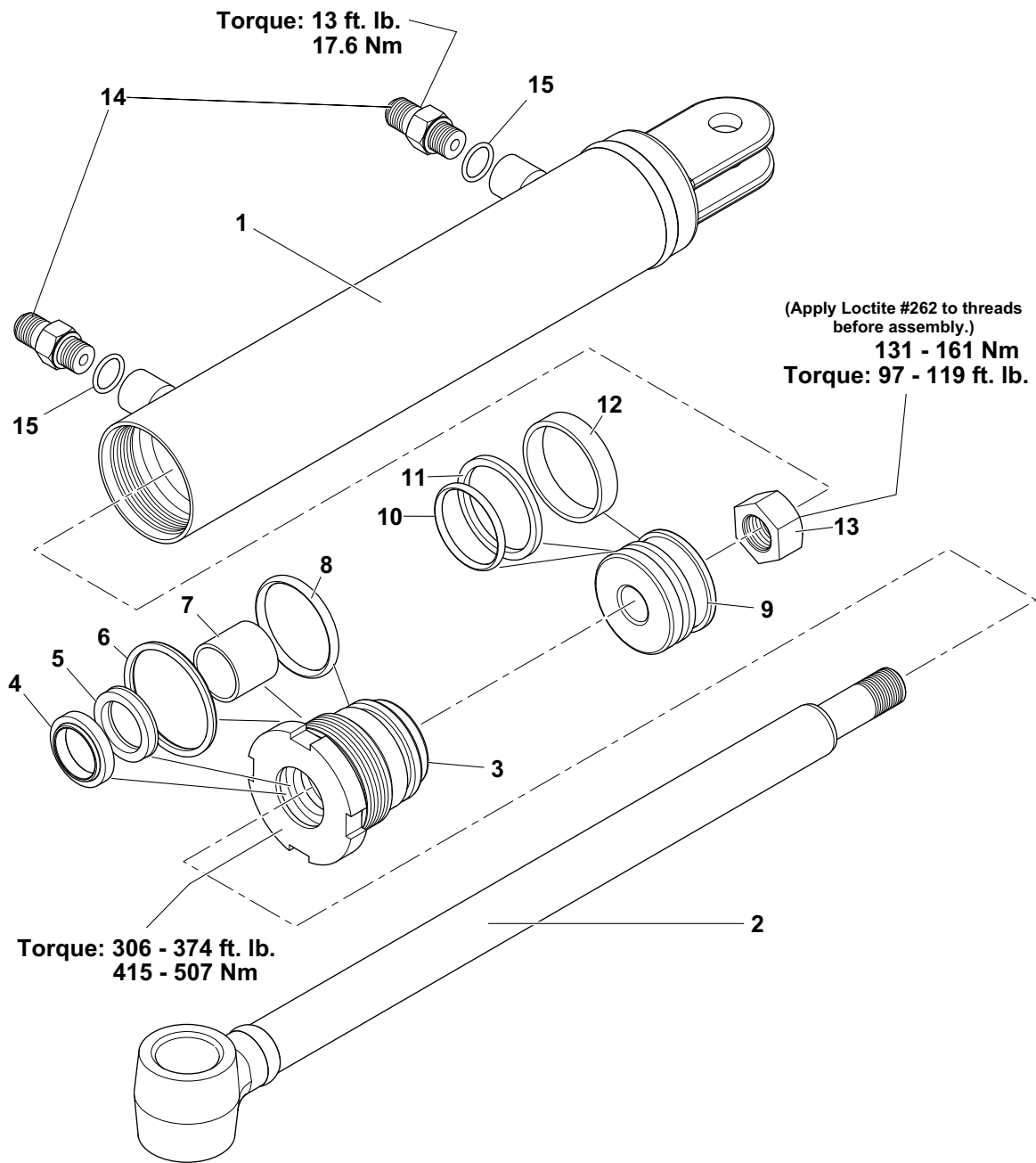

Figure 4-16. 3248RS/10RS - Steer Cylinder

- | | | |
|--------------------|-------------------|-------------------|
| 1. Cylinder Barrel | 6. O-Ring | 11. Piston Seal |
| 2. Cylinder Rod | 7. Wear Ring | 12. Wear Ring |
| 3. Head | 8. O-Ring | 13. Nut |
| 4. Wiper Seal | 9. Piston | 14. Hose Fittings |
| 5. Rod Seal | 10. Piston O-Ring | 15. O-Ring |

SECTION 5. JLG CONTROL SYSTEM

5.1 HAND HELD ANALYZER

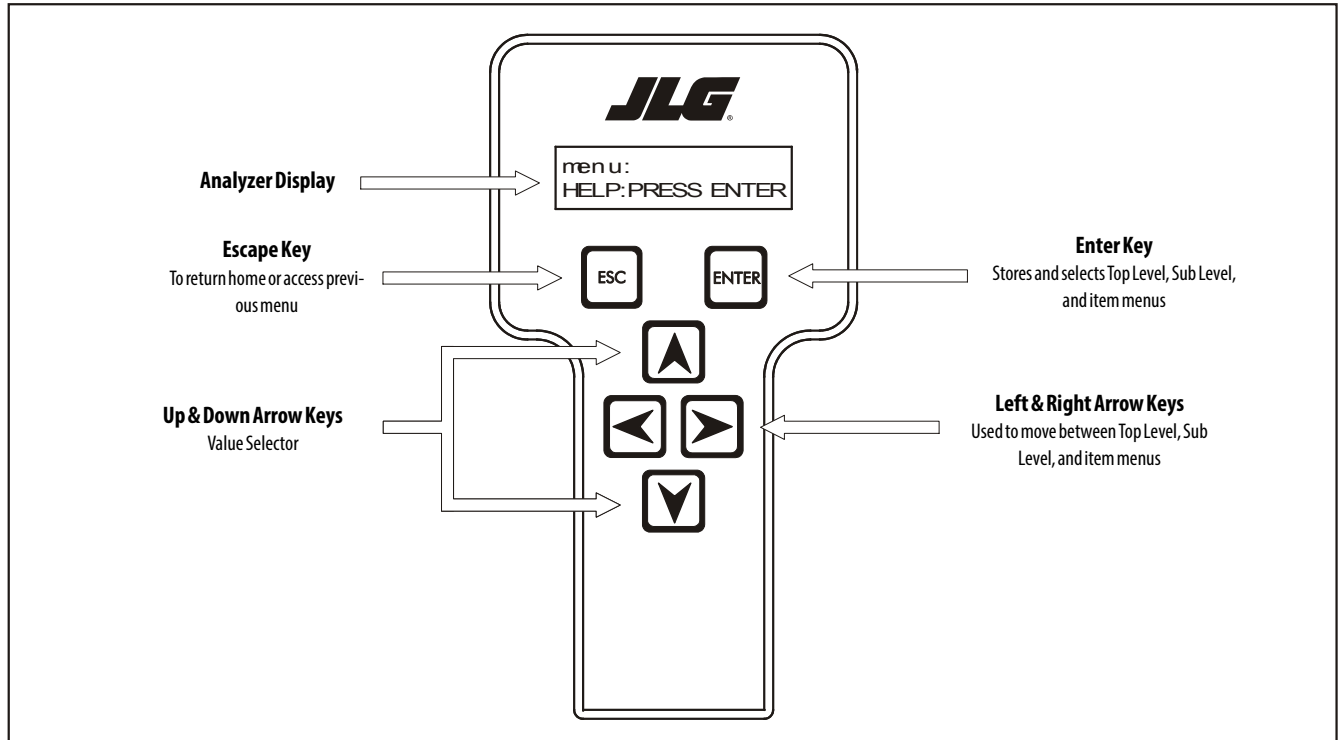

Figure 5-1. Hand Held Analyzer

Diagnostic Port

The diagnostic port to connect the Hand Held Analyzer is located behind the hydraulic cover (machine left side) at or near the ground control station as shown in Figure 5-2.

To Connect the Hand Held Analyzer

1. Connect the four pin end of the cable supplied with the analyzer, to the diagnostic port and connect the remaining end of the cable to the analyzer.

NOTE: The cable has a four pin connector at each end of the cable; the cable cannot be connected backwards.

2. Power up the Control System by turning the lower key to the platform position and pulling both emergency stop buttons on.

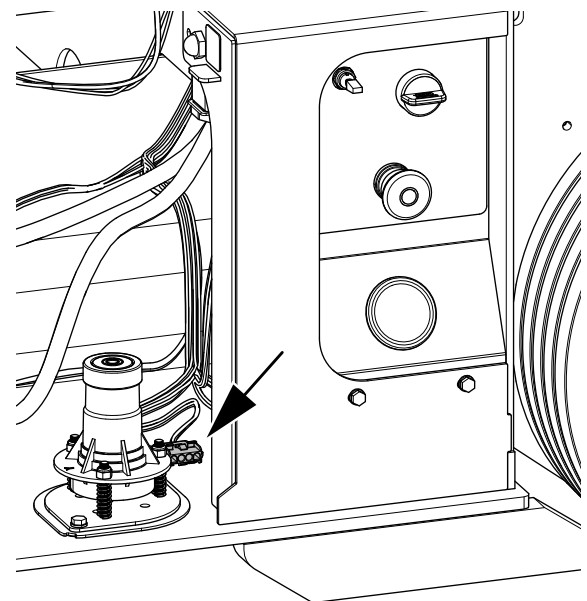
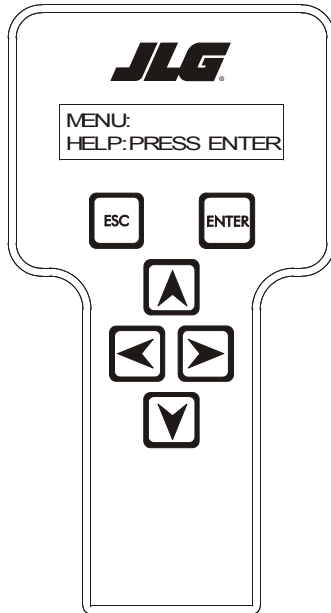

Figure 5-2. Diagnostic Port Location

Using the Analyzer:

With the machine power on and the analyzer connected properly, the analyzer will display the following:



**HELP:
PRESS ENTER**

At this point, using the **RIGHT** and **LEFT** arrow keys, you can move between the top level menu items. To select a displayed menu item, press **ENTER**. To cancel a selected menu item, press **ESC**; then you will be able to scroll using the right and left arrow keys to select a different menu item.

The top level menus are as follows:

HELP
DIAGNOSTICS
SYSTEM TEST
ACCESS LEVEL
PERSONALITIES
MACHINE SETUP
CALIBRATION
EMULATION MODE

If you press **ENTER**, at the HELP:PRESS ENTER display, and a fault is present, the analyzer display will scroll the fault across the screen. If more than one fault is present only the highest priority fault will show. The other active faults are viewable in Logged Help. If there was no fault detected, the display will read:

In platform mode,

HELP: (001)
EVERYTHING OK,

In ground mode,

HELP: (002)
GROUND MODE OK

If **ENTER** is pressed again, the display moves to the following display:

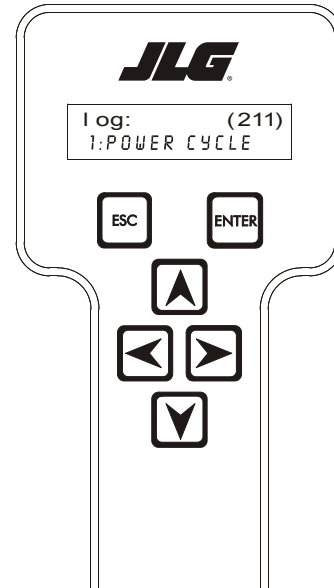

LOG: (211)
1: Power Cycle (Or last recorded fault)

At this point, the analyzer will display the highest priority active fault, if any are present. You may scroll through the fault logs to view what the last fifteen faults were. Use the right and left arrow keys to scroll through the fault logs. The active faults, are listed before the first POWER CYCLE. To return to the top menu, press **ESC** two times.

When a top level menu is selected, a new set of menu items may be offered; If for example you choose Personalities:

DRIVE
LIFT
STEER
GROUND

Pressing **ENTER** with any of the above displayed menus, will display additional sub-menus within the selected menu. In some cases the next level is the parameter or information to be changed. Refer to the flow chart for what menus are available within the top level menus. You may only view the personality settings for selected menus while in access level 2. Remember, you may always cancel a selected menu item by pressing the **ESC** key.

Changing the Access Level of the Hand Held Analyzer

When the analyzer is first connected, you will be in access level 2 which enables you to only view most configuration settings which cannot be changed until you enter a password to advance to a lower level. This ensures that a setting cannot be accidentally altered. To change the access level, the correct password must be entered. To enter the password, scroll to the **ACCESS LEVEL** menu.

For example:

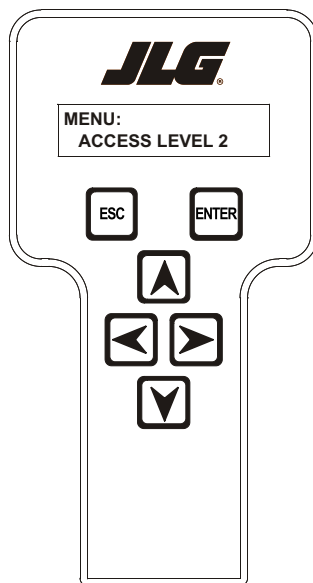

MENU:

ACCESS LEVEL 2

Press **ENTER** to select the **ACCESS LEVEL** menu.

Using the **UP** or **DOWN** arrow keys, enter the first digit of the password, 3.

Then using the **RIGHT** arrow key, position the cursor to the right one space to enter the second digit of the password.

Use the **UP** or **DOWN** arrow key to enter the second digit of the password which is 3.

Repeat this process until you have entered all five digits of the password which is **33271**.

Once the correct password is displayed, press **ENTER**. The access level should display the following, if the password was entered correctly:

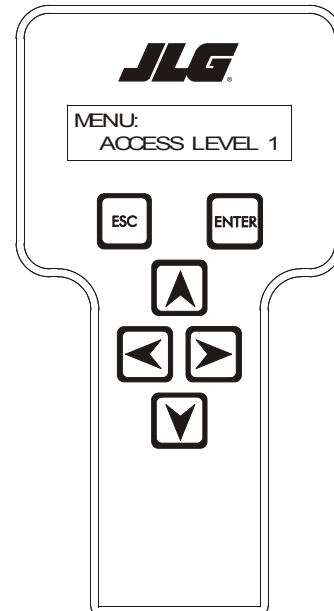

MENU:

ACCESS LEVEL 1

Repeat the above steps if the correct access level is not displayed or you can not adjust the personality settings:

Adjusting Parameters Using the Hand Held Analyzer

Once you have gained access to level 1, and a personality item is selected, press the UP or DOWN arrow keys to adjust its value, for example:

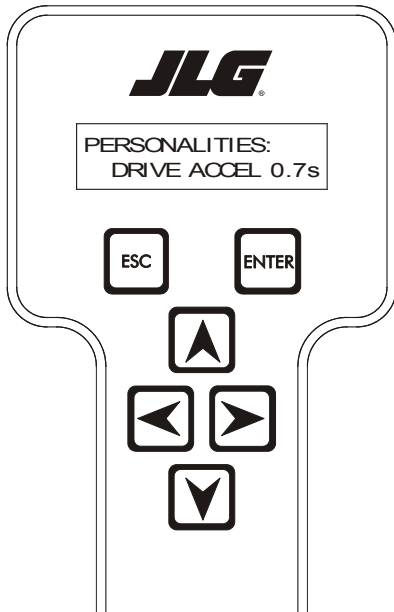

**PERSONALITIES:
DRIVE ACCEL 0.7s**

There will be a minimum and maximum for the value to ensure efficient operation. The Value will not increase if the **UP** arrow is pressed when at the maximum value nor will the value decrease if the **DOWN** arrow is pressed and the value is at the minimum value for any particular personality. If the value does not change when pressing the up and down arrows, check the access level to ensure you are at access level 1.

Machine Setup

When a machine digit item is selected, press the **UP** or **DOWN** arrow keys to adjust its value, for example:

⚠ WARNING

FAILURE TO MAKE THE PROPER SETTINGS FOR THE PARTICULAR MACHINE CAN RESULT IN IMPROPER OPERATION.

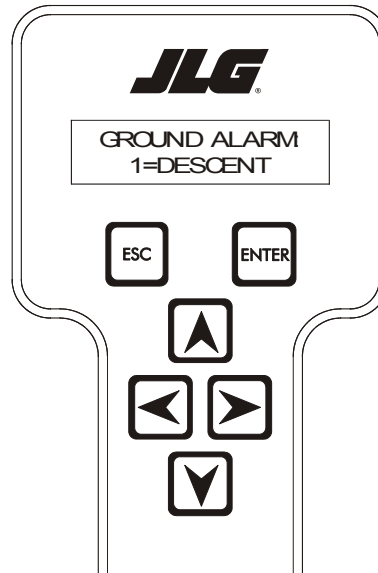

GROUND ALARM:

1=DESCENT

The effect of the machine digit value is displayed along with its value. The above display would be selected if the machine was equipped with a ground alarm and you wanted it to sound when driving. There are certain settings allowed to install optional features or select the machine model.

When selecting the machine model to match the size of the machine, the personality settings will return to default settings.

NOTE: Refer to Table 5-1, Machine Model Adjustment and Figure 5-2, Machine Configuration Programming Information (Software Version P1.7) for the default settings.

Password 33271 will give you access to level 1, which will permit you to change all machine personality and/or machine setup settings.

⚠ WARNING

CHANGING THESE SETTINGS MAY ADVERSELY AFFECT THE PERFORMANCE OF YOUR MACHINE.

Joystick Calibration

The joystick calibration should be completed if the joystick is replaced. To perform the joystick calibration both emergency stop switches must be pulled out (reset) and the ground control keyswitch set on platform mode.

1. Plug the analyzer into the machine, "Help Press Enter" should be displayed on the analyzer display.
2. Press the right arrow key to "Access Level 2".
3. Press Enter once. At this screen, you are asked to enter a password: Enter "33271" by doing the following:
 - a. Using the up and down key enter the first number.
 - b. Right arrow key once and enter the next number.
 - c. Repeat steps A and B until you have entered "33271" and press Enter.
 - d. Access level 1 should be on the display.
4. Press right arrow key to "Calibrations" and press Enter once.
5. "Calibration: Joystick" should appear, press Enter once.
6. "Cal Joystick: Yes: Enter, No: Esc" should appear, press Enter once.
7. "Cal Joystick: Fwd to Max" will appear. Move joystick completely forward and hold, then press Enter.
8. "Cal Joystick: Center" will appear. Release joystick to the neutral position and press Enter.
9. "Cal Joystick: Rev to Max" will appear. move joystick completely in the reverse position and hold, then press Enter.
10. "Cal Joystick: Complete" will appear. Power down the machine.

Updating Software

Updating the power control module software requires a laptop computer, connecting cable, and software update cd. Contact JLG Industries to acquire the software cd.

Before updating the software, use the Hand-held Analyzer to view the machine's settings (MACHINE SETUP and PERSONALITIES) (refer to Figure 5-3. thru Figure 5-9. for Analyzer Flow Chart). It is important to write down the settings to verify they are the same after software update is complete.

NOTE: *Software update must be done with the machine powered in Ground Mode.*

1. Disconnect analyzer from diagnostic port.
2. Using the laptop connector cable, connect the laptop to the diagnostic port.
3. Run the software update cd.
 - a. When the JLG Reprogramming Tool dialogue box appears, click on the Program button.
 - b. Another dialogue box will appear asking if you want to overwrite the current software version. Click YES.
4. After software update is complete, disconnect computer from diagnostic port.
5. Reconnect the hand-held analyzer to the diagnostic port.
 - a. Enter Access Level 1 password; 33271
 - b. Scroll to MACHINE SETUP. Change MODEL NUMBER to a different model, but immediately change it back to the proper setting. Do the same for MARKET. This will ensure the settings are carried over to all parameters.
 - c. Scroll through the settings to verify they are the same as before the software update.
6. Disconnect Analyzer.
7. Software update is complete.

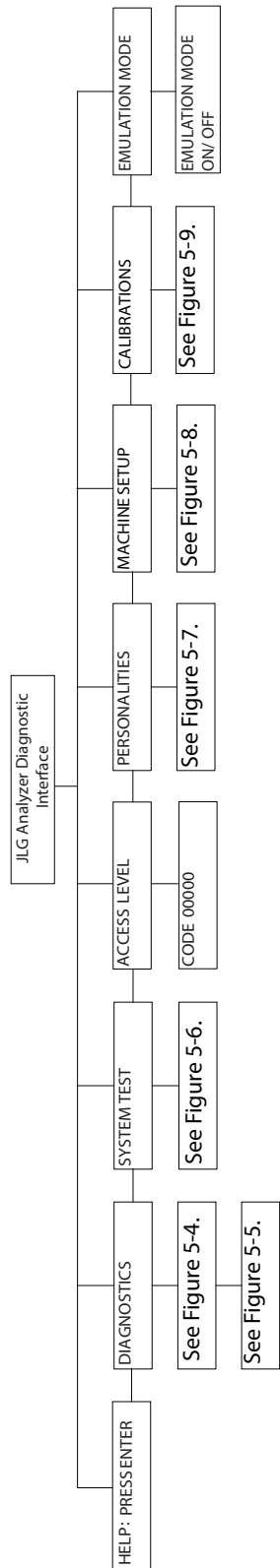

1001129850-H
MAF02420

Figure 5-3. Analyzer Flow Chart (Software Version P1.7) Sheet 1 of 7

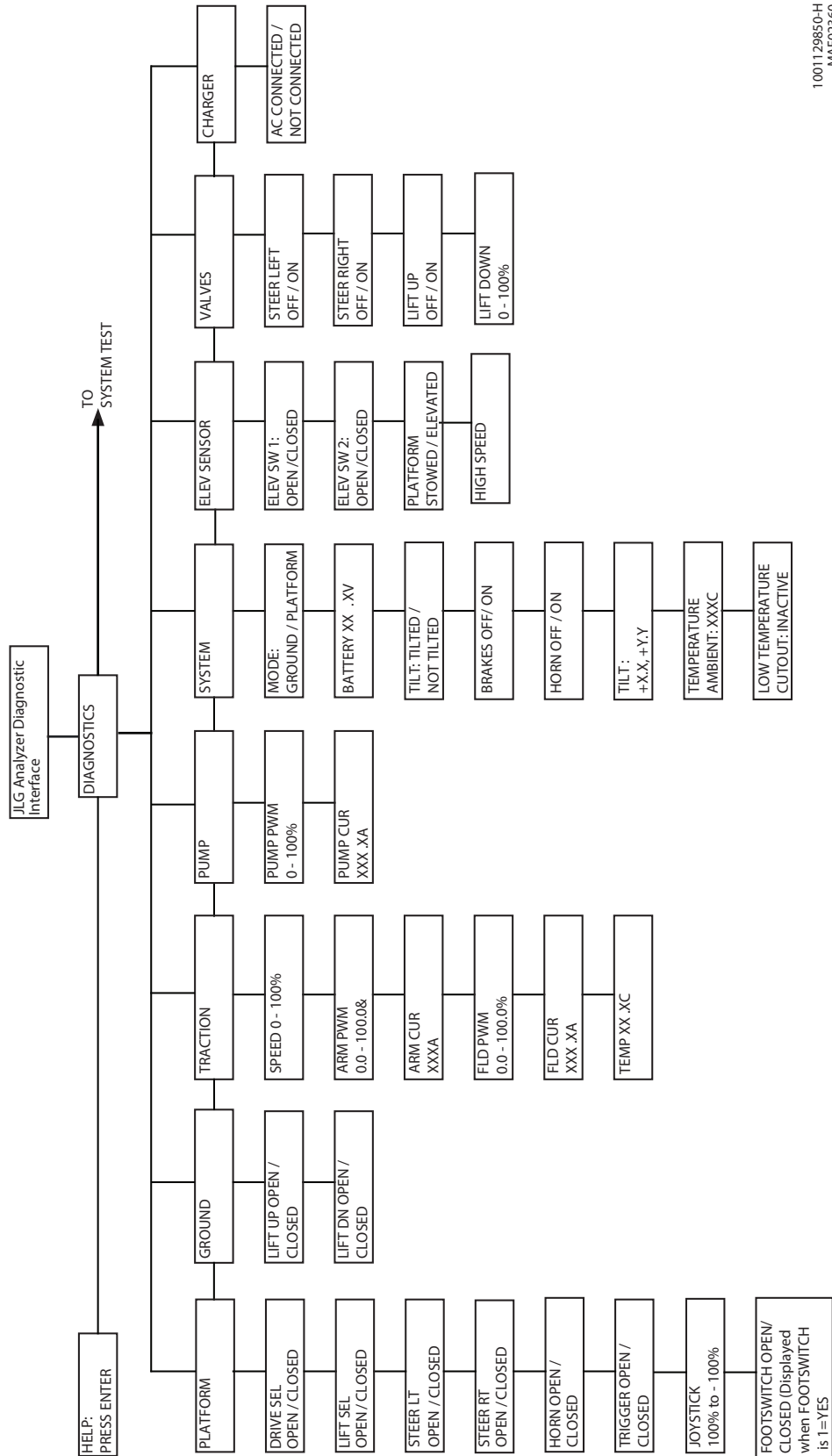

10011.29850-H
MAF02360

Figure 5-4. Analyzer Flow Chart (Software Version P1.7) Sheet 2 of 7

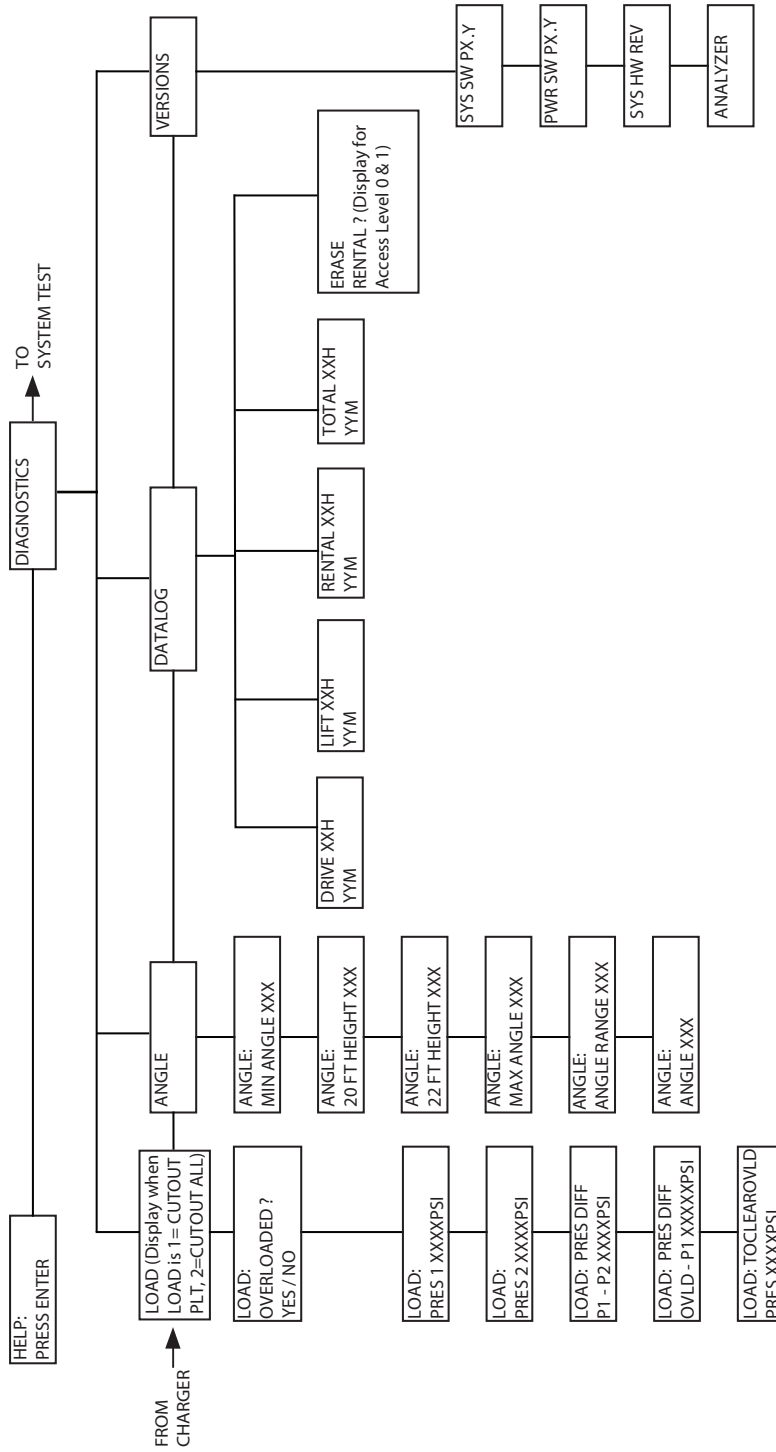

1001129850-H
MAF02370

Figure 5-5. Analyzer Flow Chart (Software Version P1.7) Sheet 3 of 7

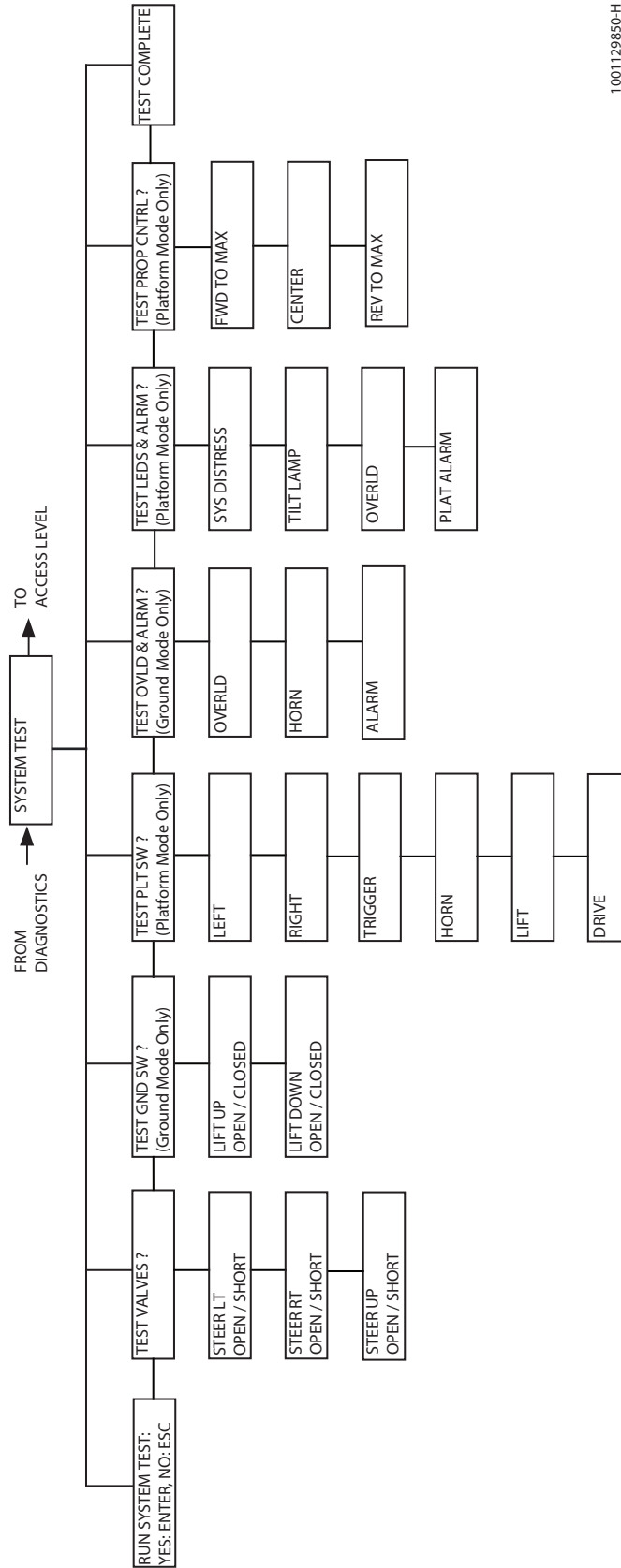

1001129850-H
MAF02380

Figure 5-6. Analyzer Flow Chart (Software Version P1.7) Sheet 4 of 7

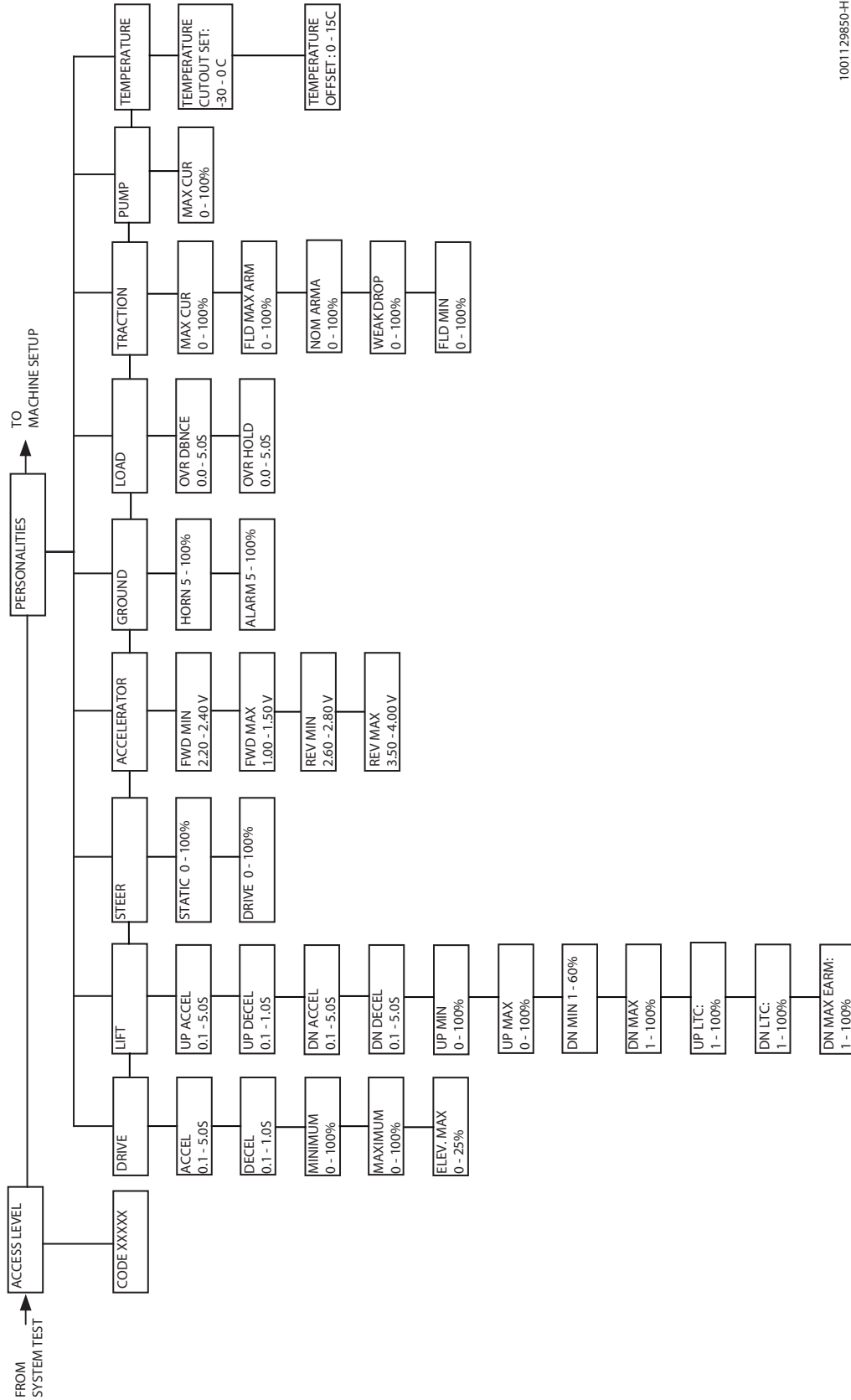

1001129850-H
MAF02390

Figure 5-7. Analyzer Flow Chart (Software Version P1.7) Sheet 5 of 7

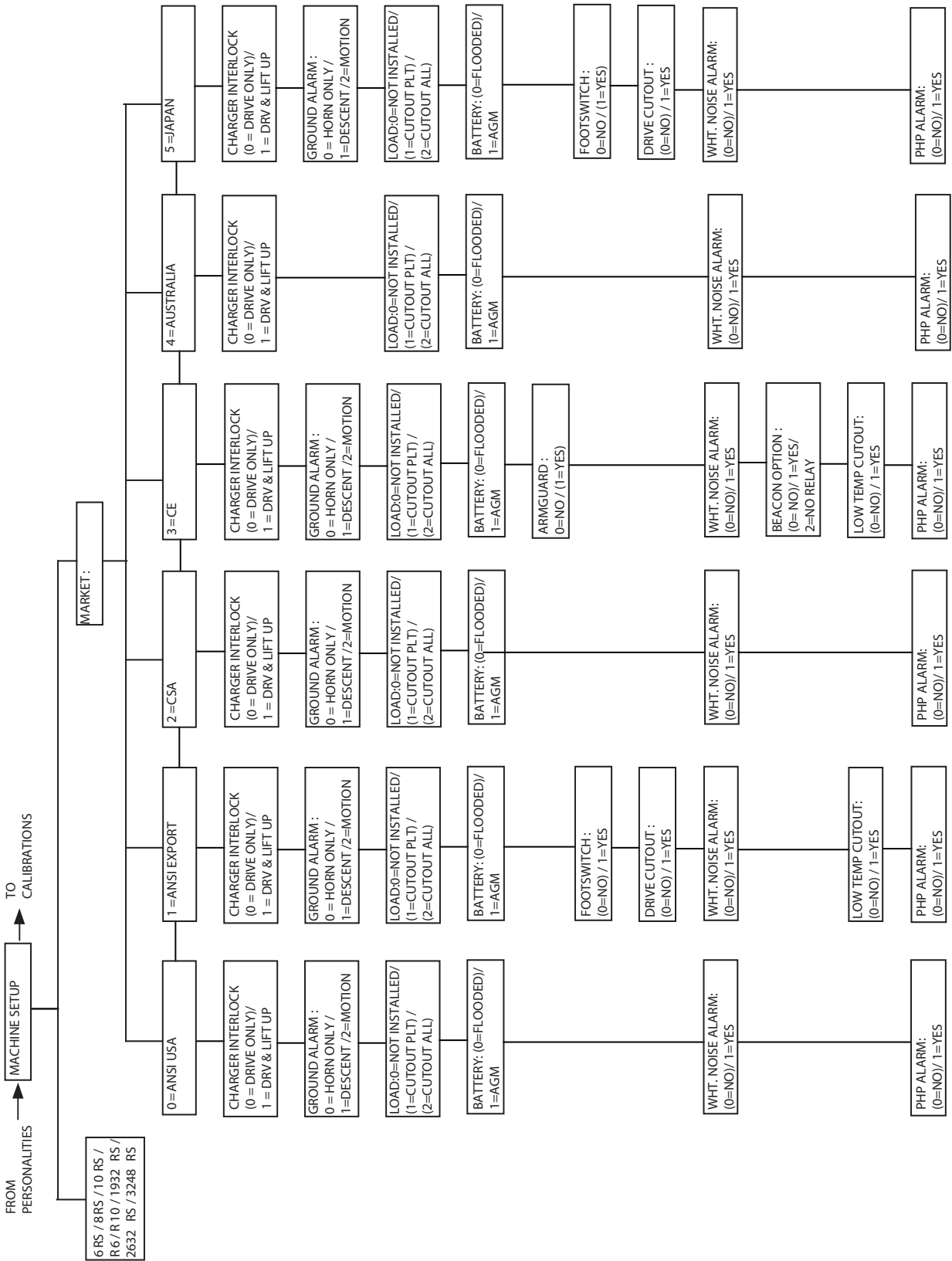

1001129850-H
MAF02400

Figure 5-8. Analyzer Flow Chart (Software Version P1.7) Sheet 6 of 7

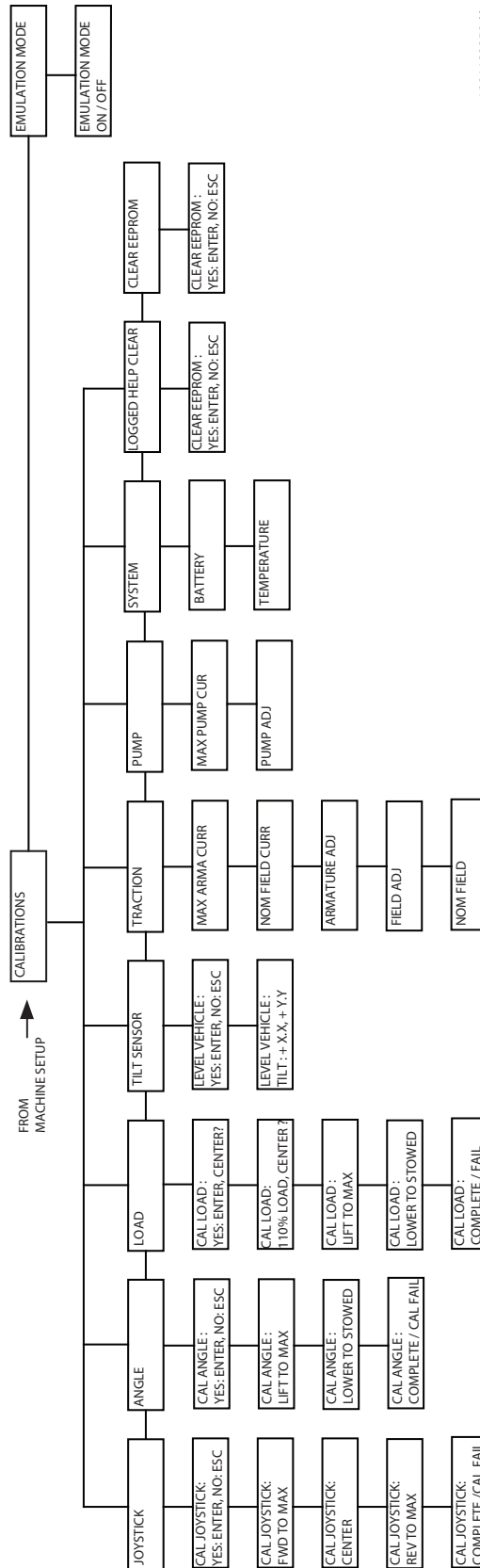

1001129850-H
MAR02410

Figure 5-9. Analyzer Flow Chart (Software Version P1.7) Sheet 7 of 7

5.2 MACHINE MODEL ADJUSTMENT

Table 5-1. Machine Model Adjustment

Adjustment	Adjustment Range	6RS	10RS	1932RS	3248RS
DRIVE					
ACCEL	0.1-5.0(Sec)	0.7	0.7	0.7	0.7
DECEL	0.1-1.0(Sec)	0.1	0.1	0.1	0.1
MINIMUM	0-25%	0	0	0	0
MAXIMUM	0-100%	100	100	100	100
ELEV. MAX.	0-30%	13	15	13	15
LIFT					
ACCEL	0.1-5.0(Sec)	0.5	0.5	0.5	0.5
DECEL	0.1-1.0(Sec)	0.1	0.1	0.1	0.1
UP MIN	0-50%	20	20	20	20
UP MAX	0-100%	100	100	100	100
DN MIN	1-60%	45	45	45	45
DN MAX	1-100%	85	85	85	85
UP LTC	1-100%	50	50	50	50
DN LTC	1-100%	77	77	77	77
DNMAX EARM	1-100%	70	70	70	70
STEER					
STATIC	0-100%	40	50	40	50
DRIVE	0-100%	20	25	20	25
ACCELERATOR					
FWD MIN	2.20-2.40V	2.23	2.23	2.23	2.23
FWD MAX	1.00-1.50V	1.19	1.19	1.19	1.19
REV MIN	2.60-2.80V	2.74	2.74	2.74	2.74
REV MAX	3.50-4.00V	3.78	3.78	3.78	3.78
GROUND					
HORN	5-100%	100	100	100	100
ALARM	5-100%	15	15	15	15
TEMP CUTOUT					
CUTOUT SET	-30-0C	-30	-30	-30	-30
OFFSET	0-15C	5	5	5	5

1001135850-E

NOTE: These settings may change in order to achieve optimal performance on a machine by machine basis.

5.3 MACHINE CONFIGURATION PROGRAMMING INFORMATION

NOTE: 1. When configuring an RS scissors machine, the machine configuration must be completed before any personality settings can be changed. Changing the personality settings first and then changing the model number of the machine configuration will cause the personality settings to return to default.

2. Shaded entries are not available for the selected Market.

Table 5-2. Machine Configuration Programming Information (Software Version P1.7)

Configuration Digit	Setting	Description	Market Default Setting					
			0	1	2	3	4	5
1 (MODEL ¹)	0	6RS	0					
	1	8RS						
	2	10RS						
	3	1932RS						
	4	2632RS						
	5	3248RS						
	6	R6						
2 (MARKET ¹)	0	ANSI USA	0					
	1	ANSI EXPORT						
	2	CSA						
	3	CE						
	4	AUSTRALIA						
	5	JAPAN						
3 (TILT CUTOUT)	0	NO - Drive and Lift Up NOT prevented while Tilted (Ground and Platform Mode).	1	1	1	1	1	1
	1	YES - Drive and Lift Up prevented while Tilted (Ground and Platform Mode).						
4 (CHARGER INTERLOCK)	0	DRIVE ONLY - Drive motion prevented while vehicle is charging.	0					
	1	DRIVE AND LIFT UP - Drive and lift up motions are prevented while vehicle is charging. Required for CE.						
5 (GROUND ALARM)	0	NOT INSTALLED - Vehicle alarm will function for Arm Guard (if enabled), Overload (if LSS enabled), and as a Horn.						
	1	DESCENT - Vehicle alarm will function for Arm Guard (if enabled), Overload (if LSS enabled), as a Horn, and during Lift Down motion.	2	2	2	0	2	2
	2	MOTION - Vehicle alarm will function for Arm Guard (if enabled), Overload (if LSS enabled), as a Horn, and during Drive and Lift motions.						
6 (LOAD)	0	NOT INSTALLED - Load Sensing System (LSS) is not fitted to the vehicle.						
	1	CUTOUT PLT - Load Sensing System (LSS) is fitted, and Platform Controls are prevented in the event of an Overload. Ground Controls remain functional. This is the default setting for CE machines.	1	1	1	2	1	1
	2	CUTOUT ALL - Load Sensing System (LSS) is fitted. Platform and Ground Controls are prevented in the event of an Overload.						
7 (BATTERY)	0	FLOODED - Batteries are conventional lead-acid type.	0					
	1	AGM - Batteries are absorbed glass mat type.						
8 (FOOT-SWITCH)	0	NO - Vehicle is not fitted with a footswitch.	0	0	0	0	0	1
	1	YES - Vehicle is fitted with a footswitch.						
9 (ARMGUARD)	0	NO - Electronic Armguard is not configured on this vehicle	0	0	0	1	0	0
	1	YES - Electronic Armguard is configured on this vehicle						
10 (LOW TEMP-CUTOUT)	0	NO - Vehicle does not have low temp cutout option	0	0	0	0	0	0
	1	YES - Vehicle has low temp cutout option						
11 (WHITENOISE ALARM)	0	NO - Vehicle does not have the white noise alarm	0	0	0	0	0	0
	1	YES - Vehicle has the white noise alarm						

Table 5-2. Machine Configuration Programming Information (Software Version P1.7)

Configuration Digit	Setting	Description	Market Default Setting					
			0	1	2	3	4	5
12 (BEACON)	0	NO - Vehicle is not configured for the beacon option, beacon only operates in descent limiter zone						
	1	YES - Vehicle has the beacon option, beacon works inside descent limit zone and outside descent limit zone	0	0	0	0	0	0
	2	NO RELAY - Vehicle does not come equipped with beacon relay and electronic armguard functionality is PREEN280						
13 (DRIVE CUTOUT)	0	NO - Vehicle is not configured with Drive cutout when elevated	0	0	0	0	0	0
	1	YES - Vehicle is configured with Drive cutout when elevated						
14 (PHP ALARM)	0	NO - Vehicle is not configured with PHP Alarm when Pothole bar is blocked	0	0	0	0	0	0
	1	YES - Vehicle is configured with PHP Alarm when Pothole bar is blocked						

1001135849-F

SECTION 6. DIAGNOSTIC TROUBLE CODES

6.1 INTRODUCTION

This section provides a reference for Diagnostic Trouble Codes (DTC) read from the Multifunction Digital Indicator (MDI) or a handheld analyzer. For more information on any sensors or indicators, refer to the appropriate manual section. Many of the checks below require configuring and using a multimeter. Refer to Section 7: General Electrical Information & Schematics for multimeter basics. To troubleshoot multiple DTCs, start with the DTC with the higher first two digits. The machine is powered by four 6 Volt batteries in series, providing a nominal 24 Volts to the control system. Some procedures below refer to this nominal voltage (VMN) as 24V. Actual voltage measurements may differ based on the charge of the batteries. **If a correction is made during a check, conclude the check by cycling the machine power, using the emergency stop switch.** It may also be helpful to run a system test, ANALYZER -> SYSTEM TEST for intermittent or difficult problems.

System Fault/DTC Indication

In addition to the DTC codes being displayed on the MDI and handheld analyzer, DTC codes are indicated by the number of flashes and pauses of the Low Battery Charge/System Fault indicator on the face of the platform control box as shown below:

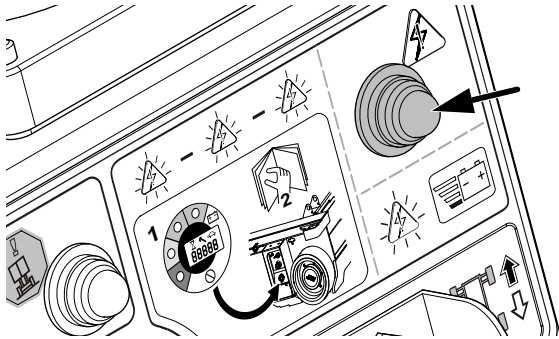

6.2 DIAGNOSTIC TROUBLE CODES (DTC)

The DTC tables following are sorted in groups by the first two digits, these digits represent the number of flashes the system distress indicator lamp will flash on the platform indicator panel when a fault occurs.

For example: a "2-1 Power-Up" on page 5 would be indicated by 2 flashes, a pause, then 1 flash, a pause, then would keep repeating until the fault is cleared.

The more detailed three digit code numbers in the DTC column of the following tables are only indicated on a JLG handheld diagnostic analyzer.

To troubleshoot multiple DTCs, start with the DTC with the higher first two digits. **If a correction is made during a check, conclude the check by cycling the machine power off then back on, using the emergency stop switch.**

NOTE: Reference to the Health (Status LED) indicator is the LED indicator on the system power module itself. (See "ZAPI Power Module Electrical Evaluation" on page 18.)

6.3 X-CONNECTOR REFERENCES

Throughout the following DTC troubleshooting procedures, electrical connectors are given a three digit identifier number preceded with an "X" for identifying and locating the specific connector on the machine.

See Section 9.8, X-CONNECTOR ID INDEX for description of "X" connectors and Figure 9-12. on page 9-20, and Figure 9-13. on page 9-21 for location of "X" connectors on the machine.

Example of "X" connector usage nomenclature:

[X006.21] refers to terminal 21 (pin and socket) of connector X006.

[X006.21.soc] refers to the socket side of terminal 21, connector X006.

[X006.21.pin] refers to the pin side of terminal 21, connector X006.

6.4 DTC INDEX

0-0 Help Comments 6-5

001 EVERYTHING OK 6-5

002 GROUND MODE OK 6-5

003 ALARM SOUNDING - TILTED & ABOVE ELEVATION (CE ONLY) 6-5

004 DRIVING AT CUTBACK - ABOVE ELEVATION 6-5

005 DRIVE & LIFT UP PREVENTED - TILTED & ELEVATED 6-5

008 FUNCTIONS LOCKED OUT - SYSTEM POWERED DOWN 6-5

2-1 Power-Up 6-5

211 POWER CYCLE 6-5

2-2 Platform Controls 6-6

221 FUNCTION PROBLEM - HORN PERMANENTLY SELECTED 6-6

223 FUNCTION PROBLEM - DRIVE & LIFT ACTIVE TOGETHER 6-6

224 FUNCTION PROBLEM - STEER LEFT PERMANENTLY SELECTED 6-6

225 FUNCTION PROBLEM - STEER RIGHT PERMANENTLY SELECTED 6-6

226 ACCELERATOR FAULTY - WIPER OUT OF RANGE 6-6

227 STEER SWITCHES FAULTY 6-6

228 FUNCTION LOCKED OUT - ACCELERATOR NOT CENTERED 6-6

229 FUNCTION PROBLEM - TRIGGER PERMANENTLY CLOSED 6-6

2210 TRIGGER CLOSED TOO LONG WHILE IN NEUTRAL 6-6

2232 FUNCTION PROBLEM - DRIVE & LIFT BOTH OPEN 6-6

2-3 Ground Controls 6-7

231 FUNCTION PROBLEM - LIFT PERMANENTLY SELECTED 6-7

232 GROUND LIFT UP / DOWN ACTIVE TOGETHER 6-7

233 FUNCTION PROBLEM - BRAKE RELEASE PERMANENTLY SELECTED 6-7

2-5 Function Prevented 6-7

253 DRIVE PREVENTED - CHARGER CONNECTED 6-7

254 DRIVE & LIFT UP PREVENTED - CHARGER CONNECTED 6-7

255 PLATFORM OVERLOADED 6-7

258 DRIVE & LIFT PREVENTED - BRAKES ELECTRICALLY RELEASED FOR TOWING 6-8

259 MODEL CHANGED - HYDRAULICS SUSPENDED - CYCLE EMS 6-8

2510 DRIVE PREVENTED - BRAKES NOT RELEASING 6-8

3-1 Line Contactor Open Circuit 6-8

311 OPEN CIRCUIT LINE CONTACTOR 6-8

314 AUXILIARY RELAY - OPEN CIRCUIT 6-8

3-2 Line Contactor Short Circuit 6-8

321 LINE CONTACTOR MISWIRED ON OR WELDED 6-8

326 AUXILIARY RELAY - SHORT TO BATTERY 6-8

3-3 Ground Output Driver 6-9

333 LIFT UP VALVE - SHORT TO BATTERY 6-9

334 LIFT UP VALVE - OPEN CIRCUIT 6-9

335 LIFT DOWN VALVE - SHORT TO BATTERY6-9

336 LIFT DOWN VALVE - OPEN CIRCUIT6-9

337 STEER LEFT VALVE - SHORT TO BATTERY6-9

338 STEER LEFT VALVE - OPEN CIRCUIT6-9

339 STEER RIGHT VALVE - SHORT TO BATTERY6-9

3310 STEER RIGHT VALVE - OPEN CIRCUIT6-9

3312 LEFT BRAKE - SHORT TO BATTERY6-10

3313 RIGHT BRAKE SHORT TO BATTERY6-10

3314 LEFT BRAKE - OPEN CIRCUIT6-10

3315 RIGHT BRAKE OPEN CIRCUIT6-10

3349 LINE CONTACTOR COIL - SHORT TO GROUND6-10

33297 LEFT BRAKE - SHORT TO GROUND6-10

33298 STEER LEFT VALVE - SHORT TO GROUND6-10

33299 LINE CONTACTOR COIL - SHORT TO BATTERY6-10

33302 NEGATIVE SUPPLY - SHORT TO BATTERY6-10

33303 NEGATIVE SUPPLY - SHORT TO GROUND6-10

33304 RIGHT BRAKE - SHORT TO GROUND6-10

33305 STEER RIGHT VALVE - SHORT TO GROUND6-10

33406 LIFT UP VALVE - SHORT TO GROUND6-10

33407 LIFT DN VALVE - SHORT TO GROUND6-10

4-2 Thermal Limit (SOA)6-11

421 POWER MODULE TOO HOT - PLEASE WAIT6-11

422 DRIVING AT CUTBACK - POWER MODULE CURRENT LIMIT6-11

423 LIFT UP AT CUTBACK - POWER MODULE CURRENT LIMIT6-11

4-4 Battery Supply6-11

441 BATTERY VOLTAGE TOO LOW - SYSTEM SHUTDOWN6-11

442 BATTERY VOLTAGE TOO HIGH - SYSTEM SHUTDOWN6-11

446 LOGIC SUPPLY VOLTAGE OUT OF RANGE6-11

4421 LOGIC SUPPLY VOLTAGE OUT OF RANGE6-11

4422 LOGIC SUPPLY VOLTAGE OUT OF RANGE6-11

6-6 Communication6-12

661 CANBUS FAILURE - POWER MODULE6-12

6643 CANBUS FAILURE - LSS ANGLE SENSOR6-12

7-7 Electric Motor6-12

772 STALLED TRACTION MOTOR OR POWER WIRING ERROR6-12

773 CAPACITOR BANK FAULT - CHECK POWER CIRCUITS6-12

774 SHORT CIRCUIT - FIELD WIRING6-12

775 OPEN CIRCUIT - FIELD WIRING6-12

776 STALLED PUMP MOTOR OR POWER WIRING ERROR6-12

777 OPEN CIRCUIT PUMP MOTOR WIRING6-12

778 TRACTION T HIGH - CHECK POWER CIRCUITS6-12

779 TRACTION T LOW - CHECK POWER CIRCUITS6-12

7710 PUMP P HIGH - CHECK POWER CIRCUITS6-12

7711 PUMP P LOW - CHECK POWER CIRCUITS6-12

7741 ARMATURE BRAKING CURRENT TOO HIGH6-13

7742 FIELD VOLTAGE IMPROPER6-13

8-2 LSS - Load Sensing System (See 3124288 - LSS Manual)6-13

8212	LSS PRESSURE SENSOR - DISAGREEMENT	6-13
8213	LSS ANGLE SENSOR - DIRECTION DISAGREEMENT	6-13
8214	LSS ANGLE SENSOR - OUT OF RANGE HIGH	6-13
8215	LSS ANGLE SENSOR - OUT OF RANGE LOW	6-13
8216	LSS ANGLE SENSOR HAS NOT BEEN CALIBRATED	6-13
825	LSS HAS NOT BEEN CALIBRATED	6-13

8-4 Elevation Switch6-13

84109	ELEVATION SWITCH CONTACTS DISAGREEMENT	6-13
-------	--	------

9-9 Hardware6-14

995	POWER MODULE FAILURE - PERSONALITY RANGE ERROR.....	6-14
996	POWER MODULE FAILURE - INTERNAL ERROR	6-14
998	EEPROM FAILURE - CHECK ALL SETTINGS	6-14
999	FUNCTION LOCKED OUT - POWER MODULE SOFTWARE VERSION IMPROPER.....	6-14
9950	POWER MODULE FAILURE - INTERNAL ERROR	6-14
9951	POWER MODULE FAILURE - INTERNAL ERROR	6-14
9952	POWER MODULE FAILURE - INTERNAL ERROR	6-14
9953	POWER MODULE FAILURE - INTERNAL ERROR	6-14
9954	POWER MODULE FAILURE - INTERNAL ERROR	6-14
9955	POWER MODULE FAILURE - INTERNAL ERROR	6-14
9956	POWER MODULE FAILURE - INTERNAL ERROR	6-14
9957	POWER MODULE FAILURE - INTERNAL ERROR	6-14
9958	POWER MODULE FAILURE - INTERNAL ERROR	6-14
9960	POWER MODULE FAILURE - INTERNAL ERROR	6-14
9962	POWER MODULE FAILURE - INTERNAL ERROR	6-14
9963	POWER MODULE FAILURE - INTERNAL ERROR	6-14
9964	POWER MODULE FAILURE - INTERNAL ERROR	6-14
9969	POWER MODULE FAILURE - INTERNAL ERROR	6-14
9970	POWER MODULE FAILURE - INTERNAL ERROR	6-14
9971	POWER MODULE FAILURE - INTERNAL ERROR	6-15
99143	POWER MODULE FAILURE - INTERNAL ERROR	6-15
99144	POWER MODULE FAILURE - INTERNAL ERROR	6-15
99145	POWER MODULE FAILURE - INTERNAL ERROR	6-15
99146	POWER MODULE FAILURE - INTERNAL ERROR	6-15
99147	POWER MODULE FAILURE - INTERNAL ERROR	6-15
99148	POWER MODULE FAILURE - INTERNAL ERROR	6-15
99149	POWER MODULE FAILURE - INTERNAL ERROR	6-15

6.5 DTC CHECK TABLES

0-0 Help Comments

DTC	FAULT MESSAGE	DESCRIPTION	CHECK
001	EVERYTHINGOK	The normal help message in platform mode. Displays on the analyzer only.	<ul style="list-style-type: none"> HEALTH (Status LED) - ON
002	GROUND MODEOK	The normal help message in ground mode. Displays on the analyzer only.	<ul style="list-style-type: none"> HEALTH (Status LED) - ON
003	ALARM SOUNDING - TILTED & ABOVE ELEVATION (CE ONLY)	Control system senses that the platform is elevated and the vehicle is tilted.	<ul style="list-style-type: none"> Check that the machine is tilted. If so, lower the platform and reposition the machine to a level surface. Fully stow the platform. The tilt sensor is mounted inside the left side chassis cover. Check that the tilt sensor is secured to the machine. Check that the elevation angle sensor is securely mounted. Backprobing ground board J1-18 should show about 0 volts. Backprobing ground board J1-10 should show about 0 volts. Adjust the tilt sensor, see Section 5.2. HEALTH (Status LED) - ON
004	DRIVING AT CUTBACK - ABOVE ELEVATION	The platform is elevated and the machine is driving in creep speed.	<ul style="list-style-type: none"> Fully stow the platform. Check that the elevation angle sensor is securely mounted. Check the lift/drive switch. Backprobing ground board J1-18 should show about 24 volts. Backprobing ground board J1-19 should show about 0 volts. HEALTH (Status LED) - ON
005	DRIVE & LIFT UP PREVENTED - TILTED & ELEVATED	Driving is not possible since the platform is elevated and the chassis is not level.	<ul style="list-style-type: none"> Check that the machine is tilted. If so, lower the platform and reposition the machine to a level surface. Fully stow the platform. The tilt sensor is mounted inside the left side chassis cover. Check that the tilt sensor is secured to the machine. Check that the elevation angle sensor is securely mounted. Backprobing ground board J1-18 should show about 24 volts. Backprobing ground board J1-19 should show about 0 volts. Adjust the tilt sensor, see Section 5.2. HEALTH (Status LED) - ON
008	FUNCTIONS LOCKED OUT - SYSTEM POWERED DOWN	A period of time elapsed without activity and the Control System entered a low-power state to preserve battery charge (2 hours).	<ul style="list-style-type: none"> Cycle the Ground EMS in Ground Mode or the Platform EMS in Platform Mode to re-enable the vehicle. HEALTH (Status LED) - ON

2-1 Power-Up

DTC	FAULT MESSAGE	DESCRIPTION	CHECK
211	POWER CYCLE	This help message is issued at each power cycle. Displays on the analyzer only.	<ul style="list-style-type: none"> Normal operation. No check necessary. HEALTH (Status LED) - ON

SECTION 6 - DIAGNOSTIC TROUBLE CODES

2-2 Platform Controls

DTC	FAULT MESSAGE	DESCRIPTION	CHECK
221	FUNCTION PROBLEM - HORN PERMANENTLY SELECTED	The horn switch was closed during power-up in platform mode.	<ul style="list-style-type: none"> Check if the horn switch is damaged, obstructed or jammed. HEALTH (Status LED) - ON
223	FUNCTION PROBLEM - DRIVE & LIFT ACTIVE TOGETHER	The Drive - Lift Selector Switch indicates that both functions are selected simultaneously	<ul style="list-style-type: none"> Check drive/lift switch for visible damage. Check switch continuity. There should only be continuity from the center post to one of the outer posts at a time. Otherwise, replace the switch. Check drive/lift switch signal and wiring to the ground module. "Lift" selection output (24V when selected) is terminal J2-3. "Drive" selection output (24V when closed) is terminal J2-13. Replace platform board. HEALTH (Status LED) - ON
224	FUNCTION PROBLEM - STEER LEFT PERMANENTLY SELECTED	The steer left switch was closed during power-up in platform mode.	<ul style="list-style-type: none"> Check if the steer left switch is obstructed or jammed. Check steer left switch and its wiring, its output (24V when closed) is to terminal J2-4. Replace platform board. HEALTH (Status LED) - ON
225	FUNCTION PROBLEM - STEER RIGHT PERMANENTLY SELECTED	The steer right switch was closed during power-up in platform mode.	<ul style="list-style-type: none"> Check if the steer right switch is obstructed or jammed. Check steer right switch and its wiring, its output (24V when closed) is to terminal J2-12. HEALTH (Status LED) - ON
226	ACCELERATOR FAULTY - WIPER OUT OF RANGE	The joystick (accelerator) wiper signal input is outside the acceptable voltage range.	<ul style="list-style-type: none"> Center joystick and check to see if a power cycle will clear DTC. The wiper wire may be off, shorted to +B, or shorted to -B (ground) to cause this difficulty. Check voltage on MS35 connector pins - A - 5V, B - 0.5 to 4.5V, and C - 0V. HEALTH (Status LED) - ON
227	STEER SWITCHES FAULTY	Both the Steer Left and Steer Right Inputs are closed as the same time.	<ul style="list-style-type: none"> Check if the steer switches are damaged, obstructed or jammed. A short in the Steer Switch wiring or a failed Steer Switch can cause this difficulty. Check the steer switch signals and wiring outputs (24V when closed) to terminals J2-4 and J2-12 (left and right). HEALTH (Status LED) - ON
228	FUNCTION LOCKED OUT - ACCELERATOR NOT CENTERED	Selected function (Drive or Lift) is not allowed because the joystick (accelerator) was not centered at power-up.	<ul style="list-style-type: none"> Release joystick and allow to center. Check if the joystick is obstructed or jammed. Check the joystick signal and its wiring. Check voltage at MS35. HEALTH (Status LED) - ON
229	FUNCTION PROBLEM - TRIGGER PERMANENTLY CLOSED	Trigger Switch in the Platform Control Box was closed at power-up.	<ul style="list-style-type: none"> Check if the trigger switch is obstructed or jammed. Release switch or repair the switch / wiring to clear the difficulty. Check the trigger switch signal and wiring. The trigger input (24V when closed) is to terminal J2-10. HEALTH (Status LED) - ON
2210	TRIGGER CLOSED TOO LONG WHILE IN NEUTRAL	Trigger Switch in the Platform Control Box was closed for more than five seconds while the Joystick (accelerator) was in the neutral position (centered)	<ul style="list-style-type: none"> Release switch or repair the switch / wiring to clear the difficulty. Check if the trigger switch is obstructed or jammed. Check the trigger switch signal and wiring. The trigger input (24V when closed) is to terminal J2-10. HEALTH (Status LED) - ON
2232	FUNCTION PROBLEM - DRIVE & LIFT BOTH OPEN	In Platform Mode, the Drive - Lift Selector Switch indicates that neither function is selected.	<ul style="list-style-type: none"> Repair the wiring or switch to clear the message. Check if either function is active, if Yes; HEALTH (Status LED) - ON

2-3 Ground Controls

DTC	FAULT MESSAGE	DESCRIPTION	CHECK
231	FUNCTION PROBLEM - LIFT PERMANENTLY SELECTED	Lift Switch (Up or Down) in the Ground Control Box was closed during power-up.	<ul style="list-style-type: none"> Release or repair the switch to clear the message. Check if the lift switch is obstructed or jammed. Check the lift switch signal and wiring. The lift switch outputs (24V when closed) are to ground board terminals J1-27, J1-10 (up and down). Replace ground board. HEALTH (Status LED) - ON
232	GROUND LIFT UP / DOWN ACTIVE TOGETHER	In Ground Mode, the control system has detected the Lift Up and Down are active simultaneously	<ul style="list-style-type: none"> Check the Lift Switch and associated wiring in the Ground Control Box. Check if the lift switch is obstructed or jammed. Check the lift switch signal and wiring to the ground board. The lift switch outputs (24V when closed) to ground board terminals J1-27 (up), J1-10 (down). Replace ground board. HEALTH (Status LED) - ON
233	FUNCTION PROBLEM - BRAKE RELEASE PERMANENTLY SELECTED	The manual brake release switch was closed during power-up.	<ul style="list-style-type: none"> Release or repair the switch to clear the message Check if the brake release switch is obstructed or jammed. Check the brake release switch signal and wiring to the ground board. The brake release switch input (24V) is from ground board terminal J1-31, and its output (24V when closed) is to ground board terminal J1-25. If the brakes are released, the machine can be pushed or moved without drive motor power. Replace ground board. HEALTH (Status LED) - ON

2-5 Function Prevented

DTC	FAULT MESSAGE	DESCRIPTION	CHECK
253	DRIVE PREVENTED - CHARGER CONNECTED	Driving is not possible while the vehicle is charging and it is configured to only allow lifting.	<ul style="list-style-type: none"> Check if the charger is connected to off board power source and disconnect if desired. Check ANALYZER -> MACHINE SETUP -> CHARGER INTERLOC is set as desired. Check that charger's red (positive) battery wire connector terminal is receiving power (24V) from batteries. Check signal from charger interlock connector terminal 2 to ground board terminal J1-26, where OVDC indicates charging in process. HEALTH (Status LED) - ON
254	DRIVE & LIFT UP PREVENTED - CHARGER CONNECTED	Drive or lift is not possible while the vehicle is charging and is configured to prevent all motion.	<ul style="list-style-type: none"> Check if the charger is connected to off board power source and disconnect if desired. Check ANALYZER -> MACHINE SETUP -> CHARGER INTERLOC is set as desired. (Must be in ACCESS LEVEL 1 to change.) Check that charger's red (positive) battery wire connector terminal is receiving power (24V) from batteries. Check signal from charger interlock connector terminal 2 to ground board terminal J1-26, where OVDC indicates charging in process. HEALTH (Status LED) - ON
255	PLATFORM OVERLOADED	The load sensing system measured platform load is excessive.	<ul style="list-style-type: none"> Remove excess weight from the platform. Check that the platform is not caught on something, preventing up or down movement. If any CAN bus faults are active, troubleshoot those first. Refer to Troubleshooting in the LSS manual, 3124288.

SECTION 6 - DIAGNOSTIC TROUBLE CODES

2-5 Function Prevented

DTC	FAULT MESSAGE	DESCRIPTION	CHECK
258	DRIVE & LIFT PREVENTED - BRAKES ELECTRICALLY RELEASED FOR TOWING	Manual brake release mode is activated with the switch under the left side chassis cover near the ground control box. Drive or lift is not possible.	<ul style="list-style-type: none"> • Push manual brake release switch again or cycle power to clear manual brake release mode. • Check if the brake release switch is obstructed or jammed. • Check the brake release switch signal and wiring to the ground board. The switch input (24V) is from ground board terminal J1-31, and its output (24V when closed) is to ground board terminal J1-25. • Replace ground board. • HEALTH (Status LED) - ON
259	MODEL CHANGED - HYDRAULICS SUSPENDED - CYCLE EMS	The user changed the Model Selection using the JLG Analyzer.	<ul style="list-style-type: none"> • Check ANALYZER -> MACHINE SETUP -> MODEL NUMBER. • Cycle Emergency Stop Switch. • Replace ground board. • HEALTH (Status LED) - ON
2510	DRIVE PREVENTED - BRAKES NOT RELEASING	While driving on a level surface, armature current was > 150A for five seconds. Brakes assumed to not be releasing properly.	<ul style="list-style-type: none"> • Ensure vehicle is not stuck on something preventing movement. • Examine both drive motor brakes for electrical (open- and short-circuits) and mechanical (rust, corrosion, contamination) issues that prevent them from releasing. • HEALTH (Status LED) - ON

3-1 Line Contactor Open Circuit

DTC	FAULT MESSAGE	DESCRIPTION	CHECK
311	OPEN CIRCUIT LINE CONTACTOR	The System Module's Line Contactor did not close when energized.	<ul style="list-style-type: none"> • Check contactor main contact wiring to battery (+) terminal and power controller terminal B+. • Contactor solenoid resistance should measure about 52 Ohms. • Check contactor solenoid wiring to terminals J1-13 and J1-32. • Replace the line contactor. • HEALTH (Status LED) - ON
314	AUXILIARY RELAY - OPEN CIRCUIT	The auxiliary relay did not close when energized.	<ul style="list-style-type: none"> • Check the auxiliary relay coil and associated wiring to J1-13 and J1-32. • No voltage on J1-28. • HEALTH (Status LED) - ON

3-2 Line Contactor Short Circuit

DTC	FAULT MESSAGE	DESCRIPTION	CHECK
321	LINE CONTACTOR MISWIRED ON OR WELDED	The Line contactor is off, but the System Module is being energized.	<ul style="list-style-type: none"> • Check wiring of contactor. • Check resistance between the studs of the contactor while disconnected from the machine. • Check contactor main contact wiring to battery (+) terminal and power module terminal B+. • Check continuity between contactor connector pin 1 and ground board socket J1-13. • Check continuity between contactor connector pin 2 and ground module J1-32. • Measure voltage between power model B+ and B- terminals. If 24V is present, replace line contactor. • Replace power module. • HEALTH (Status LED) - ON
326	AUXILIARY RELAY - SHORT TO BATTERY	The Auxiliary Relay has not been energized by the System Module, but J1-28 is energized.	<ul style="list-style-type: none"> • The Auxiliary Relay's contacts or coil may be mis-wired • There is a wire harness issue that allows +B to reach J1-28. This situation will cause the batteries to discharge while the vehicle is turned off. • Alternately, the Auxiliary Relay is faulty, replace Auxiliary Relay. • HEALTH (Status LED) - ON

 **3-3 Ground Output Driver**

DTC	FAULT MESSAGE	DESCRIPTION	CHECK
333	LIFT UP VALVE - SHORT TO BATTERY	Voltage from an external source was detected on the Lift Up Solenoid (J2-17 NUV).	<ul style="list-style-type: none"> • Check for continuity through this circuit. The lift up solenoid resistance should measure about 30 Ohms. The lift up solenoid is powered with 24V from ground board J2-1, and its ground is to ground board J2-17. • Inspect the wiring for physical damage. • Replace ground board. • HEALTH (Status LED) - ON
334	LIFT UP VALVE - OPEN CIRCUIT	Current flow to the Lift Up Solenoid was not detected (J2-17 NUV).	<ul style="list-style-type: none"> • Check for continuity through this circuit. The lift up solenoid resistance should measure about 30 Ohms. The lift up solenoid is powered with 24V from ground board, and its ground is to ground board. • Inspect the wiring for physical damage. • Replace ground board. • HEALTH (Status LED) - ON
335	LIFT DOWN VALVE - SHORT TO BATTERY	The power module detected voltage while the lift down solenoid was commanded off. (J2-2 PDV or J2-16 NDV)	<ul style="list-style-type: none"> • Check ANALYZER -> MACHINE SETUP -> ELEV PROX is set to NOT INSTALLED • Check for continuity through this circuit. The lift down solenoid resistance should measure about 20 Ohms. The lift down solenoid is powered (PWM) by ground board J2-2, and its ground is to ground board J2-16. • Inspect the wiring for physical damage. • Replace ground board. • HEALTH (Status LED) - ON
336	LIFT DOWN VALVE - OPEN CIRCUIT	The power module did not detect current flow to the lift down solenoid during normal operation. (J2-16 NDV)	<ul style="list-style-type: none"> • Check for continuity through this circuit. The lift down solenoid resistance should measure about 20 Ohms. The lift down solenoid is powered (PWM) by ground board, and its ground is to ground board. • Inspect the wiring for physical damage. • Replace ground board. • HEALTH (Status LED) - ON
337	STEER LEFT VALVE - SHORT TO BATTERY	Voltage from an external source was detected on the Steer Left Solenoid (J2-9 NLV).	<ul style="list-style-type: none"> • Check for continuity through this circuit. Steer left solenoid resistance should measure about 30 Ohms. The steer left solenoid is powered with 24V from ground board J2-1, and its ground is to ground board J2-9. • Inspect the wiring for physical damage. • Replace ground board. • HEALTH (Status LED) - ON
338	STEER LEFT VALVE - OPEN CIRCUIT	Current flow to the Steer Left Solenoid was not detected (J2-9 NLV).	<ul style="list-style-type: none"> • Check for continuity through this circuit. Steer left solenoid resistance should measure about 30 Ohms. The steer left solenoid is powered with 24V from ground board, and its ground is to ground board. • Inspect the wiring for physical damage. • Replace ground board. • HEALTH (Status LED) - ON
339	STEER RIGHT VALVE - SHORT TO BATTERY	Voltage from an external source was detected on the Steer Right Solenoid (J2-18 NRV).	<ul style="list-style-type: none"> • Check for continuity through this circuit. Steer right solenoid resistance should measure about 30 Ohms. The steer right solenoid is powered with 24V from ground board J2-1, and its ground is to ground board J2-18. • Inspect the wiring for physical damage. • Replace ground board. • HEALTH (Status LED) - ON
3310	STEER RIGHT VALVE - OPEN CIRCUIT	Current flow to the Steer Right Solenoid was not detected (J2-18 NRV).	<ul style="list-style-type: none"> • Check for continuity through this circuit. Steer right solenoid resistance should measure about 30 Ohms. The steer right solenoid is powered with 24V from ground board, and its ground is to ground board. • Inspect the wiring for physical damage. • Replace ground board. • HEALTH (Status LED) - ON

SECTION 6 - DIAGNOSTIC TROUBLE CODES

3-3 Ground Output Driver

DTC	FAULT MESSAGE	DESCRIPTION	CHECK
3312	LEFT BRAKE - SHORT TO BATTERY	Voltage from an external source was detected on the Left Brake Solenoid (J1-34 NLB).	<ul style="list-style-type: none"> Check for continuity through this circuit. The left brake is powered with 24V from ground board J1-29, and its ground is to ground board J1-34. Brake solenoid resistance should measure about 20 Ohms. Inspect the wiring for physical damage. Replace ground board.
3313	RIGHT BRAKE SHORT TO BATTERY	Voltage from an external source was detected on the Right Brake Solenoid (J1-33 NRB).	<ul style="list-style-type: none"> Check for continuity through this circuit. Brake solenoid resistance should measure about 20 Ohms. The right brake is powered with 24V from ground board J1-30, and its ground is to ground board J1-33. Inspect the wiring for physical damage. Replace ground board.
3314	LEFT BRAKE - OPEN CIRCUIT	Current flow to the Left Brake Solenoid was not detected (J1-34 NLB).	<ul style="list-style-type: none"> Check for continuity through this circuit. The left brake is powered with 24V from ground board, and its ground is to ground board. Brake solenoid resistance should measure about 20 Ohms. Inspect the wiring for physical damage. Replace ground board. HEALTH (Status LED) - ON
3315	RIGHT BRAKE OPEN CIRCUIT	Current flow to the Right Brake Solenoid was not detected (J1-33 NRB).	<ul style="list-style-type: none"> Check for continuity through this circuit. Brake solenoid resistance should measure about 20 Ohms. The right brake is powered with 24V from ground board, and its ground is to ground board. Inspect the wiring for physical damage. Replace ground board. HEALTH (Status LED) - ON
3349	LINE CONTACTOR COIL - SHORT TO GROUND	An external short to ground was detected on the Negative Main Line Contactor (J1-32 NMC).	<ul style="list-style-type: none"> HEALTH (Status LED) - ON
33297	LEFT BRAKE - SHORT TO GROUND	Excessive current flow to the Left Brake Solenoid was detected (J1-34 NLB).	<ul style="list-style-type: none"> HEALTH (Status LED) - ON
33298	STEER LEFT VALVE - SHORT TO GROUND	Excessive current flow to the steer left solenoid detected (J2-9 NLV).	<ul style="list-style-type: none"> HEALTH (Status LED) - ON
33299	LINE CONTACTOR COIL - SHORT TO BATTERY	Voltage from an external source was detected on the Negative Main Line Contactor.	<ul style="list-style-type: none"> HEALTH (Status LED) - ON
33302	NEGATIVE SUPPLY - SHORT TO BATTERY	At power-up, the system module detected an external short on J1-12, J1-17, J1-23, J2-14 or J2-15 when in platform mode. Normally these pins are grounded by the System Module. All functions are prevented to protect the control system.	<ul style="list-style-type: none"> HEALTH (Status LED) - ON
33303	NEGATIVE SUPPLY - SHORT TO GROUND	At power-up, the System Module detected an external short on J1-12, J1-17, J2-14 or J2-15 when in platform mode. Normally these pins are grounded by the System Module. Since the external ground may compromise integrity, all functions will be prevented.	<ul style="list-style-type: none"> HEALTH (Status LED) - ON
33304	RIGHT BRAKE - SHORT TO GROUND	Excessive current flow to the Right Brake solenoid was detected (J1-33 NRB).	<ul style="list-style-type: none"> HEALTH (Status LED) - ON
33305	STEER RIGHT VALVE - SHORT TO GROUND	Excessive current flow to the Steer Right Solenoid was detected (J2-18 NRV).	<ul style="list-style-type: none"> HEALTH (Status LED) - ON
33406	LIFT UP VALVE - SHORT TO GROUND	Excessive current flow to the Lift Up Solenoid was detected (J2-17 NUV).	<ul style="list-style-type: none"> HEALTH (Status LED) - ON
33407	LIFT DN VALVE - SHORT TO GROUND	Excessive current flow to the Lift Down Solenoid was detected (J2-16 NDV).	<ul style="list-style-type: none"> HEALTH (Status LED) - ON

4-2 Thermal Limit (SOA)

DTC	FAULT MESSAGE	DESCRIPTION	CHECK
421	POWER MODULE TOO HOT - PLEASE WAIT	The System Module's internal temperature is excessive (>+75°C). Allow to cool by powering down.	<ul style="list-style-type: none"> Power down and allow to cool. Do not operate in ambients over 140° F (60° C). Check for jammed or obstructed drive motors. Check for excessively high current consumption in the pump, ANALYZER -> DIAGNOSTICS -> PUMP -> PUMP CUR over 130 Amps with an empty deck. Check for excessively high traction current consumption, ANALYZER -> DIAGNOSTICS -> TRACTION -> ARM CUR over 120 Amps while driving on the level. HEALTH (Status LED) - ON
422	DRIVING AT CUTBACK - POWER MODULE CURRENT LIMIT	Armature current was greater than 250A for at least 60 seconds. To avoid damage to the vehicle, the System Module has reduced the current limit to 120A.	<ul style="list-style-type: none"> Check for jammed or obstructed drive motors. Check for excessively high traction current consumption, ANALYZER -> DIAGNOSTICS -> TRACTION -> ARM CUR over 120 Amps while driving on the level. HEALTH (Status LED) - ON
423	LIFT UP AT CUTBACK - POWER MODULE CURRENT LIMIT	Pump current was greater than 150A for at least 60 seconds. To avoid damage to the vehicle, the System Module has reduced the current limit to 80A	<ul style="list-style-type: none"> Check for jammed or obstructed arm stack or pivot bushing. Check for excessively high current consumption in the pump, ANALYZER -> DIAGNOSTICS -> PUMP -> PUMP CUR over 130 Amps with an empty deck. Refer to Section 4.3, Pump/Motor. HEALTH (Status LED) - ON

4-4 Battery Supply

DTC	FAULT MESSAGE	DESCRIPTION	CHECK
441	BATTERY VOLTAGE TOO LOW - SYSTEM SHUTDOWN	Battery Voltage momentarily dropped below 14.5V when using flooded lead-acid batteries, or 16.0V when using AGM batteries. With a low battery charge, this can occur during heavy current demand due to Drive, Steer, or Lift Up.	<ul style="list-style-type: none"> Recharge batteries or check for damaged batteries. Check battery charger function. HEALTH (Status LED) - ON
442	BATTERY VOLTAGE TOO HIGH - SYSTEM SHUTDOWN	The System Module momentarily measured excessively high battery voltage (>36.0V) and de-energized the Main Line Contactor and Battery Relay to protect system devices.	<ul style="list-style-type: none"> May be due to improper battery charging or incorrect voltage batteries being used. HEALTH (Status LED) - ON
446	LOGIC SUPPLY VOLTAGE OUT OF RANGE	The system module logic supply voltage was measured to be out of normal operating range by the interface PCB (<11V).	<ul style="list-style-type: none"> This may be caused by a loose battery terminal, severely discharged batteries, damaged battery, or an improper wire harness connection. Drive, Steer, and Lift Prevented HEALTH (Status LED) - ON
4421	LOGIC SUPPLY VOLTAGE OUT OF RANGE	The system module logic supply voltage was measured by the power PCB to be more than 34V for 10uS.	<ul style="list-style-type: none"> This may be caused by a loose battery terminal, severely discharged batteries, damaged battery, or an improper wire harness connection. Drive, Steer, and Lift Prevented HEALTH (Status LED) - ON
4422	LOGIC SUPPLY VOLTAGE OUT OF RANGE	The system module logic supply voltage was measured by the power PCB to be less than 11V for 10uS.	<ul style="list-style-type: none"> This may be caused by a loose battery terminal, severely discharged batteries, damaged battery, or an improper wire harness connection. Drive, Steer, and Lift Prevented HEALTH (Status LED) - ON

SECTION 6 - DIAGNOSTIC TROUBLE CODES

6-6 Communication

DTC	FAULT MESSAGE	DESCRIPTION	CHECK
661	CANBUS FAILURE - POWER MODULE	The control system failed to receive messages from the power microprocessor.	<ul style="list-style-type: none"> This may occur if re-programming was interrupted. Alternately, this may be an internal fault. HEALTH (Status LED) - ON
6643	CANBUS FAILURE - LSS ANGLE SENSOR	The control system failed to receive messages from the angle sensor.	<ul style="list-style-type: none"> Check wiring to the Angle Sensor. HEALTH (Status LED) - ON

7-7 Electric Motor

DTC	FAULT MESSAGE	DESCRIPTION	CHECK
772	STALLED TRACTION MOTOR OR POWER WIRING ERROR	The System Module detected armature current feedback > 4.5V or < 0.5V.	<ul style="list-style-type: none"> This is mostly likely caused by a stalled traction motor or power wiring issue. Alternately, it could be an internal fault. HEALTH (Status LED) - ON
773	CAPACITOR BANK FAULT - CHECK POWER CIRCUITS	There is an internal or external fault that prevents the System Module's capacitor bank from charging.	<ul style="list-style-type: none"> The System Module detected that the VMN of the pump and traction has not increased more than 1.3V in 1000mS. Alternately, the VMN of the pump or traction is less than 20% of battery voltage. If this message persists after disconnecting the drive and pump wiring, there is an internal fault. HEALTH (Status LED) - ON
774	SHORT CIRCUIT - FIELD WIRING	The field wiring passed System Module power-up diagnostics. However, an external short circuit was detected when current was applied to F1 / F2.	<ul style="list-style-type: none"> This situation is caused by improper field wiring or a damaged motor. HEALTH (Status LED) - ON
775	OPEN CIRCUIT - FIELD WIRING	The System Module applied field current, but could regulate the desired current.	<ul style="list-style-type: none"> The situation is caused by improper field wiring or a damaged motor. HEALTH (Status LED) - ON
776	STALLED PUMP MOTOR OR POWER WIRING ERROR	The System Module measured improper pump current feedback (> 4.5V or < 0.5V) for 240mS.	<ul style="list-style-type: none"> This is caused by a stalled pump motor, a power wiring issue, or a System Module malfunction. HEALTH (Status LED) - ON
777	OPEN CIRCUIT PUMP MOTOR WIRING	This indicates there is an open-circuit between the System Module's -P terminal and the pump motor.	<ul style="list-style-type: none"> The System Module measured pump current less than 8A while the motor voltage was greater than 7V for 1200mS. HEALTH (Status LED) - ON
778	TRACTION T HIGH - CHECK POWER CIRCUITS	While driving, the voltage measured at the System Module's T-terminal did not agree with the predicted value.	<ul style="list-style-type: none"> This issue may be caused by a power wiring error or an internal fault. HEALTH (Status LED) - ON
779	TRACTION T LOW - CHECK POWER CIRCUITS	While driving, the voltage measured at the System Module's T terminal did not agree with the predicted value.	<ul style="list-style-type: none"> This issue may be caused by an open circuit of the armature wiring (+B and -T terminals) or an internal fault. VMN does not increase more than 1.3V VMN is less than 20% Battery Voltage Battery Voltage . VMN is greater than 4V HEALTH (Status LED) - ON
7710	PUMP P HIGH - CHECK POWER CIRCUITS	While steering or lifting up, the voltage measured at the System Module's P terminal did not agree with the predicted value.	<ul style="list-style-type: none"> This issue may be caused by a power wiring error or an internal fault. Pump Feedback . Predicted >7V HEALTH (Status LED) - ON
7711	PUMP P LOW - CHECK POWER CIRCUITS	While steering or lifting up, the voltage measured at the System Module's P terminal did not agree with the predicted value.	<ul style="list-style-type: none"> This issue may be caused by an open-circuit of the pump wiring (+BF2 and -P terminals) or an internal fault. Pump feedback does not increase more than 1.3V Pump feedback is less than 20% Battery Voltage Battery Voltage - pump feedback is greater than 4V HEALTH (Status LED) - ON

7-7 Electric Motor

DTC	FAULT MESSAGE	DESCRIPTION	CHECK
7741	ARMATURE BRAKING CURRENT TOO HIGH	The System Module detected excessive braking current.	<ul style="list-style-type: none"> This can be caused by transporting an excessive load on a steep grade. Alternately, this may indicate an internal fault. HEALTH (Status LED) - ON
7742	FIELD VOLTAGE IMPROPER	The System Module voltage at the F1 and F2 terminals was improper at power-up (expected to be ½ Battery Voltage).	<ul style="list-style-type: none"> This is caused by an open- or short-circuit in the field wiring or motor. Disconnect the field and motor wiring from the System Module and connect F1 / F2 with a short wire. If the situation persists after a power cycle, it may be an internal issue. HEALTH (Status LED) - ON

8-2 LSS - Load Sensing System (See 3124288 - LSS Manual)

DTC	FAULT MESSAGE	DESCRIPTION	CHECK
8212	LSS PRESSURE SENSOR - DISAGREEMENT	Pressure Sensor 1 and Pressure Sensor 2 do not agree. The system shall assume the machine is overloaded until the sensors agree.	<ul style="list-style-type: none"> Using the Analyzer LOAD submenu under DIAGNOSTICS check PRES1 and PRES2 readings. They must agree within 75 PSI. With the safety prop engaged check to ensure that the appropriate voltage is being supplied to both sensors and that the wiring and connections are intact. The voltage between pins A and B should read +5V +/- 0.5V with the machine turned on. If the voltage supplied is correct, replace both transducers. HEALTH (Status LED) - ON
8213	LSS ANGLE SENSOR - DIRECTION DISAGREEMENT	The angle sensor's change in reading does not agree with the direction of the machine motion (lift up).	<ul style="list-style-type: none"> This indicates a wiring error or Angle Sensor malfunction. HEALTH (Status LED) - ON
8214	LSS ANGLE SENSOR - OUT OF RANGE HIGH	The Angle Sensor's reading when the machine is at maximum elevation does not fall within the high end acceptable range	<ul style="list-style-type: none"> The Angle Sensors reading must be less than or equal to 245 counts at maximum elevation. Ensure that the Angle Sensor is mounted properly. HEALTH (Status LED) - ON
8215	LSS ANGLE SENSOR - OUT OF RANGE LOW	The angle sensor's reading when the machine is stowed does not fall within the low end acceptable range.	<ul style="list-style-type: none"> The Angle Sensors reading must be greater than or equal to 5 counts with the platform stowed. Ensure that the Angle Sensor is mounted properly. HEALTH (Status LED) - ON
8216	LSS ANGLE SENSOR HAS NOT BEEN CALIBRATED	The Angle Sensor has never been calibrated and the control system assumes that the platform is overloaded.	<ul style="list-style-type: none"> Calibrate the Angle Sensor using the CALIBRATION: ANGLE submenu to clear the message. HEALTH (Status LED) - ON
825	LSS HAS NOT BEEN CALIBRATED	The Load Sensing System has never been calibrated and the control system assumes that the platform is overloaded.	<ul style="list-style-type: none"> Empty Platform and Calibrate the Load Sensing System using the calibration procedure in the LSS Manual. HEALTH (Status LED) - ON

8-4 Elevation Switch

DTC	FAULT MESSAGE	DESCRIPTION	CHECK
84109	ELEVATION SWITCH CONTACTS DISAGREEMENT	The Elevation Switch contacts are the same (high or low). Since the contacts should always be complimentary, the system assumes the platform is Elevated.	<ul style="list-style-type: none"> Check the wiring and the switch or replace the switch to clear the fault. Health (Status LED) - ON

SECTION 6 - DIAGNOSTIC TROUBLE CODES

9-9 Hardware

DTC	FAULT MESSAGE	DESCRIPTION	CHECK
995	POWER MODULE FAILURE - PERSONALITY RANGE ERROR	The power module detected an out-of-range or corrupt personality setting	<ul style="list-style-type: none"> Record all personality settings in ANALYZER -> PERSONALITIES and ANALYZER -> MACHINE SETUP. Reset control system personalities to default settings by selecting a different model than indicated, cycle power then select proper model. Then, enter personality settings recorded above. Health (Status LED) - ON
996	POWER MODULE FAILURE - INTERNAL ERROR		<ul style="list-style-type: none"> This is an internal failure. Cycle machine, if error still exists, replace System Module. HEALTH (Status LED) - FLASHING
998	EEPROM FAILURE - CHECK ALL SETTINGS	The control system detected an EEPROM failure.	<ul style="list-style-type: none"> Personalities and Machine Setup settings may be reset to default values. Check/Correct all settings and re-cycle power to clear difficulty. Health (Status LED) - ON
999	FUNCTION LOCKED OUT - POWER MODULE SOFTWARE VERSION IMPROPER	The power module software version is not compatible with the rest of the system.	<ul style="list-style-type: none"> Re-program or replace with a Version 1.xx module Health (Status LED) - ON
9950	POWER MODULE FAILURE - INTERNAL ERROR		<ul style="list-style-type: none"> Cycle machine, if error still exists, replace System Module. HEALTH (Status LED) - FLASHING
9951	POWER MODULE FAILURE - INTERNAL ERROR		<ul style="list-style-type: none"> Cycle machine, if error still exists, replace System Module. HEALTH (Status LED) - FLASHING
9952	POWER MODULE FAILURE - INTERNAL ERROR		<ul style="list-style-type: none"> Cycle machine, if error still exists, replace System Module. HEALTH (Status LED) - FLASHING
9953	POWER MODULE FAILURE - INTERNAL ERROR		<ul style="list-style-type: none"> Cycle machine, if error still exists, replace System Module. HEALTH (Status LED) - FLASHING
9954	POWER MODULE FAILURE - INTERNAL ERROR		<ul style="list-style-type: none"> Cycle machine, if error still exists, replace System Module. HEALTH (Status LED) - FLASHING
9955	POWER MODULE FAILURE - INTERNAL ERROR		<ul style="list-style-type: none"> Cycle machine, if error still exists, replace System Module. HEALTH (Status LED) - FLASHING
9956	POWER MODULE FAILURE - INTERNAL ERROR		<ul style="list-style-type: none"> Cycle machine, if error still exists, replace System Module. HEALTH (Status LED) - FLASHING
9957	POWER MODULE FAILURE - INTERNAL ERROR		<ul style="list-style-type: none"> Cycle machine, if error still exists, replace System Module. HEALTH (Status LED) - FLASHING
9958	POWER MODULE FAILURE - INTERNAL ERROR		<ul style="list-style-type: none"> Cycle machine, if error still exists, replace System Module. HEALTH (Status LED) - FLASHING
9960	POWER MODULE FAILURE - INTERNAL ERROR		<ul style="list-style-type: none"> Cycle machine, if error still exists, replace System Module. HEALTH (Status LED) - FLASHING
9962	POWER MODULE FAILURE - INTERNAL ERROR		<ul style="list-style-type: none"> Cycle machine, if error still exists, replace System Module. HEALTH (Status LED) - FLASHING
9963	POWER MODULE FAILURE - INTERNAL ERROR	The System Module detected a mismatch in the redundant RAM information stored in the power PCB.	<ul style="list-style-type: none"> Cycle machine, if error still exists, replace System Module. HEALTH (Status LED) - ON
9964	POWER MODULE FAILURE - INTERNAL ERROR		<ul style="list-style-type: none"> Cycle machine, if error still exists, replace System Module. HEALTH (Status LED) - FLASHING
9969	POWER MODULE FAILURE - INTERNAL ERROR		<ul style="list-style-type: none"> Cycle machine, if error still exists, replace System Module. HEALTH (Status LED) - FLASHING
9970	POWER MODULE FAILURE - INTERNAL ERROR	The System Module detected a mismatch in the redundant RAM information stored in the interface PCB.	<ul style="list-style-type: none"> Cycle machine, if error still exists, replace System Module. HEALTH (Status LED) - ON

 9-9 Hardware

DTC	FAULT MESSAGE	DESCRIPTION	CHECK
9971	POWER MODULE FAILURE - INTERNAL ERROR		<ul style="list-style-type: none"> • Cycle machine, if error still exists, replace System Module. • HEALTH (Status LED) - FLASHING
99143	POWER MODULE FAILURE - INTERNAL ERROR		<ul style="list-style-type: none"> • Cycle machine, if error still exists, replace System Module. • HEALTH (Status LED) - FLASHING
99144	POWER MODULE FAILURE - INTERNAL ERROR		<ul style="list-style-type: none"> • Cycle machine, if error still exists, replace System Module. • HEALTH (Status LED) - FLASHING
99145	POWER MODULE FAILURE - INTERNAL ERROR		<ul style="list-style-type: none"> • Cycle machine, if error still exists, replace System Module. • HEALTH (Status LED) - FLASHING
99146	POWER MODULE FAILURE - INTERNAL ERROR		<ul style="list-style-type: none"> • Cycle machine, if error still exists, replace System Module. • HEALTH (Status LED) - FLASHING
99147	POWER MODULE FAILURE - INTERNAL ERROR		<ul style="list-style-type: none"> • Cycle machine, if error still exists, replace System Module. • HEALTH (Status LED) - FLASHING
99148	POWER MODULE FAILURE - INTERNAL ERROR		<ul style="list-style-type: none"> • Cycle machine, if error still exists, replace System Module. • HEALTH (Status LED) - FLASHING
99149	POWER MODULE FAILURE - INTERNAL ERROR		<ul style="list-style-type: none"> • Cycle machine, if error still exists, replace System Module. • HEALTH (Status LED) - FLASHING

SECTION 7. GENERAL ELECTRICAL INFORMATION & SCHEMATICS

7.1 GENERAL

This section contains schematics to be used for locating and correcting most of the operating problems which may develop. If a problem should develop which is not presented in this section or which is not corrected by listed corrective actions, technically qualified guidance should be obtained before proceeding with any maintenance.

NOTICE

IT IS A GOOD PRACTICE TO AVOID PRESSURE-WASHING ELECTRICAL/ELECTRONIC COMPONENTS. SHOULD PRESSURE-WASHING BE UTILIZED TO WASH AREAS CONTAINING ELECTRICAL/ELECTRONIC COMPONENTS, JLG INDUSTRIES, INC. RECOMMENDS A MAXIMUM PRESSURE OF 750 PSI (52 BAR) AT A MINIMUM DISTANCE OF 12 INCHES (30.5 CM) AWAY FROM THESE COMPONENTS. IF ELECTRICAL/ELECTRONIC COMPONENTS ARE SPRAYED, SPRAYING MUST NOT BE DIRECT AND BE FOR BRIEF TIME PERIODS TO AVOID HEAVY SATURATION.

7.2 MULTIMETER BASICS

A wide variety of multimeters or Volt Ohm Meters (VOM) can be used for troubleshooting your equipment. A digital meter with reasonable accuracy (within 7%) is recommended for the measurements in these procedures. This section shows diagrams of a common, digital VOM configured for several different circuit measurements. Instructions for your VOM may vary. Please consult the meter operator's manual for more information.

Grounding

"Grounding the meter" means to take the black lead (which is connected to the COM (common) or negative port) and touch it to a good path to the negative side of the voltage source.

Backprobing

To "backprobe" means to take the measurement by accessing a connector's contact on the same side as the wires, the back of the connector. Readings can be done while maintaining circuit continuity this way. If the connector is the sealed type, great care must be taken to avoid damaging the seal around the wire. It is best to use probes or probe tips specifically designed for this technique, especially on sealed connectors. Whenever possible insert probes into the side of the connector such that the test also checks both terminals of the connection. It is possible to inspect a connection within a closed connector by backprobing both sides of a connector terminal and measuring resistance. Do this after giving each wire a gentle pull to ensure the wires are still attached to the contact and contacts are seated in the connector.

Min/Max

Use of the "Min/Max" recording feature of some meters can help when taking measurements of intermittent conditions while alone. For example, you can read the voltage applied to a solenoid when it is only operational while a switch, far from the solenoid and meter, is held down.

Polarity

Finding a negative voltage or current reading when expecting a positive reading frequently means the leads are reversed. Check what reading is expected, the location of the signal and that the leads are connected to the device under test correctly. Also check that the lead on the "COM" port goes to the ground or negative side of the signal and the lead on the other port goes to the positive side of the signal.

Scale

M = Mega = 1,000,000 * (Displayed Number)

k = kilo = 1,000 * (Displayed Number)

m = milli = (Displayed Number) / 1,000

μ = micro = (Displayed Number) / 1,000,000

Example: 1.2 kW = 1200 W

Example: 50 mA = 0.05 A

Voltage Measurement

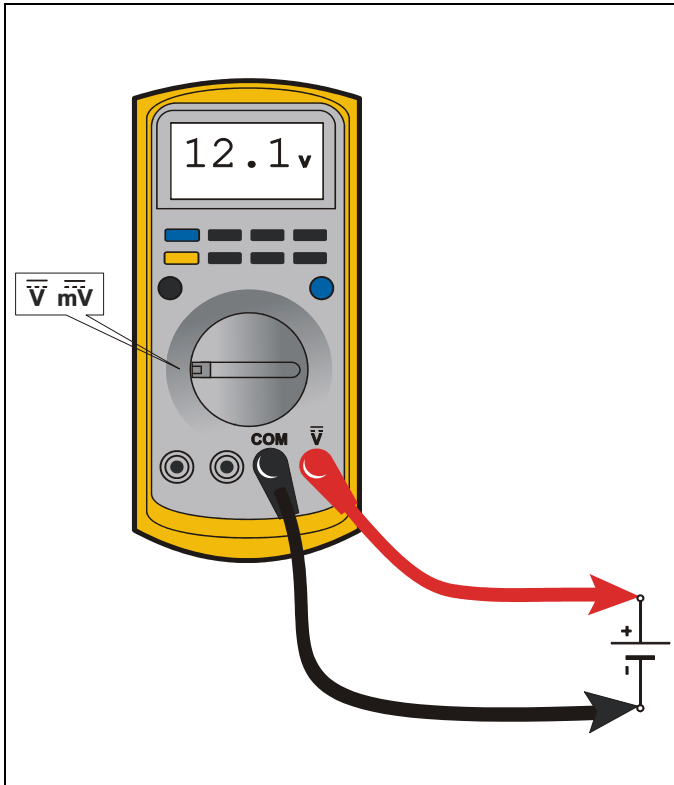

Figure 7-1. Voltage Measurement (DC)

- If meter is not auto ranging, set it to the correct range (See multimeter's operation manual)
- Use firm contact with meter leads

Resistance Measurement

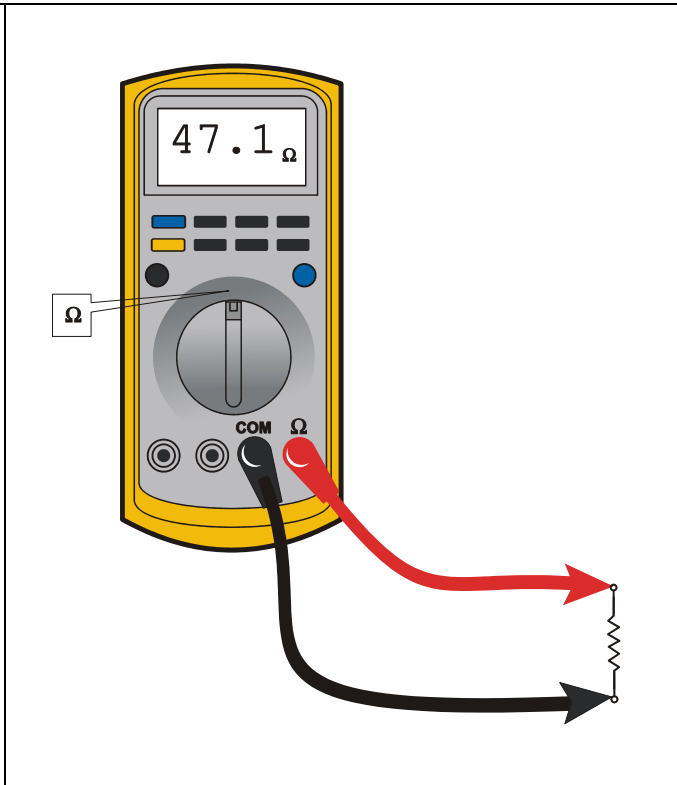

Figure 7-2. Resistance Measurement

- First test meter and leads by touching leads together. Resistance should read a short circuit (very low resistance)
- Circuit power must be turned OFF before testing resistance
- Disconnect component from circuit before testing
- If meter is not auto ranging, set it to the correct range (See multimeter's operation manual)
- Use firm contact with meter leads

Continuity Measurement

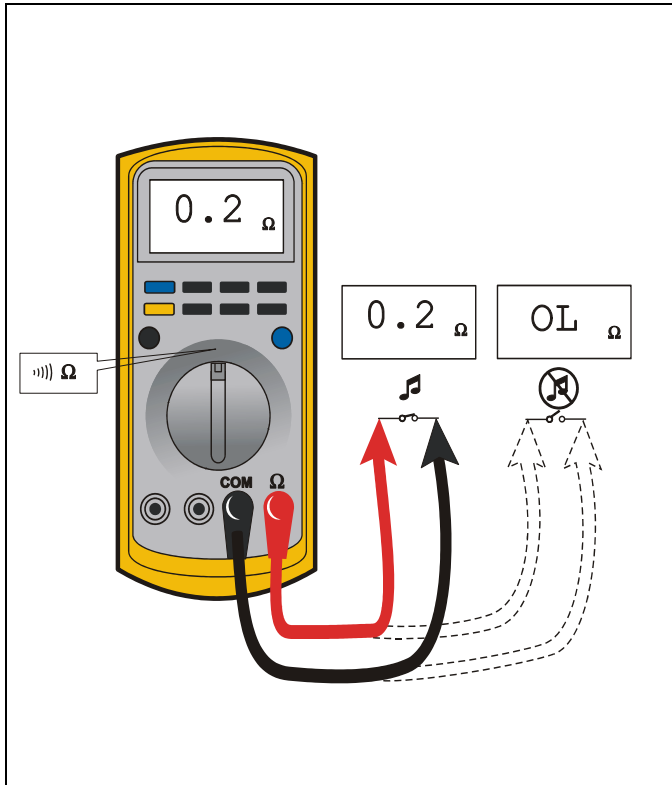

Figure 7-3. Continuity Measurement

- Some meters require a separate button press to enable audible continuity testing
- Circuit power must be turned OFF before testing continuity
- Disconnect component from circuit before testing
- Use firm contact with meter leads
- First test meter and leads by touching leads together. Meter should produce an audible alarm, indicating continuity

Current Measurement

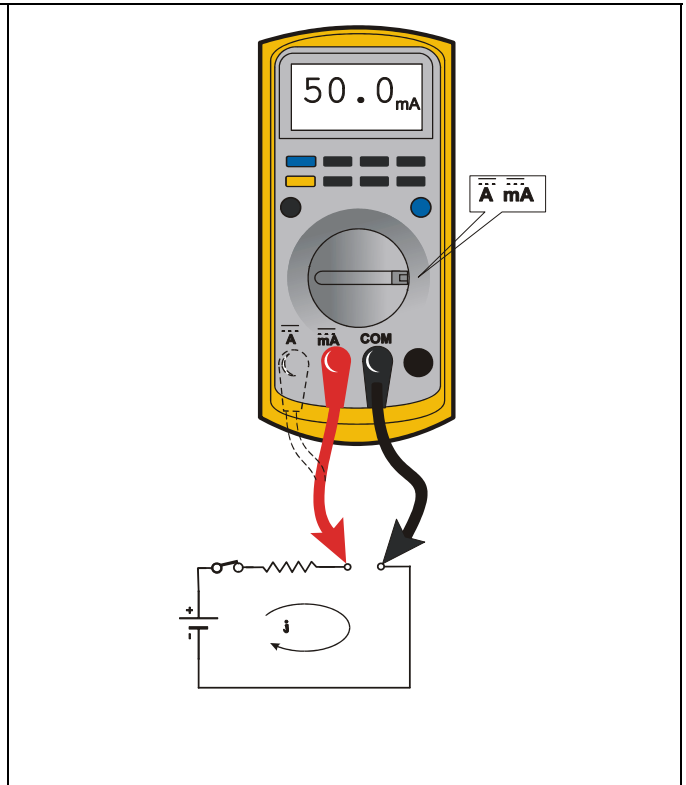

Figure 7-4. Current Measurement (DC)

- Set up the meter for the expected current range
- Be sure to connect the meter leads to the correct jacks for the current range you have selected
- If meter is not auto ranging, set it to the correct range (See multi meter's operation manual)
- Use firm contact with meter leads

Continuity Measurement Over Long Distances

When trying to determine continuity of a harness or wire, longer than the reach of standard instrument leads, is possible to perform the check without excessively long leads. Using the other wires in the harness one can determine the condition of a particular wire in the harness.

Requirements:

- Harness with at least three separate wires including the wire under test.
- These wires must be able to be isolated from other wires, etc.
- Jumper or method to connect contacts on one side of harness.
- Meter that can measure resistance or continuity.

Procedure

Test multimeter leads resistance. Subtract this value from the measured resistance of the wires to get a more accurate measurement.

Consult the circuit schematic to determine which wires to use in addition to wire under test, here called wire #1 and wire #2, and how to isolate these wires. These wires should appear in the same connectors as the wire under test or are within reach of the jumper.

1. Disconnect all connections associated with the wire under test and the two additional wires. If harness is not completely isolated disconnect battery terminals also, as a precaution.
2. Measure continuity between all three wires, the wire under test, wire #1 and wire #2. These should be open. If not, repair the shorted wires or replace the harness.
3. On one side, jumper from contact of wire #1 and wire #2.
4. Measure continuity between wire #1 and wire #2. If there is continuity, both wires are good and can be used for this test. If there is not continuity, either wire could be bad. Check connections and measurement setup. Redo measurement. If still no continuity, repair wires or consult schematic for other wires to use for test.
5. Jumper from wire under test to wire #1.
6. Measure continuity. If there is continuity, the wire under test is good. Resistance of a wire increases as the length increases and as the diameter decreases.

One can find the continuity of two wires, here #1 and #2, at once by following steps 1 through 4. If there is a problem the third wire is used to troubleshoot the other wires. To find the problem, start at step 1 and use the entire procedure.

7.3 APPLYING SILICONE DIELECTRIC COMPOUND TO AMP CONNECTORS

Silicone Dielectric Compound must be used on the AMP connections for the following reasons:

- To prevent oxidation at the mechanical joint between male and female pins.
- To prevent electrical malfunction caused by low level conductivity between pins when wet.

Use the following procedure to apply Silicone Dielectric Compound to the electrical connectors.

1. To prevent oxidation and low level conductivity, silicone dielectric grease must be packed completely around male and female pins on the inside of the connector after the mating of the housing to the header. This is easily achieved by using a syringe to fill the header with silicone dielectric compound, to a point just above the top of the male pins inside the header. When assembling the housing to the header, it is possible that the housing will become air locked, thus preventing the housing latch from engaging.
2. Pierce one of the unused wire seals to allow the trapped air inside the housing to escape.
3. Install a hole plug into this and/or any unused wire seal that has silicone dielectric compound escaping from it.

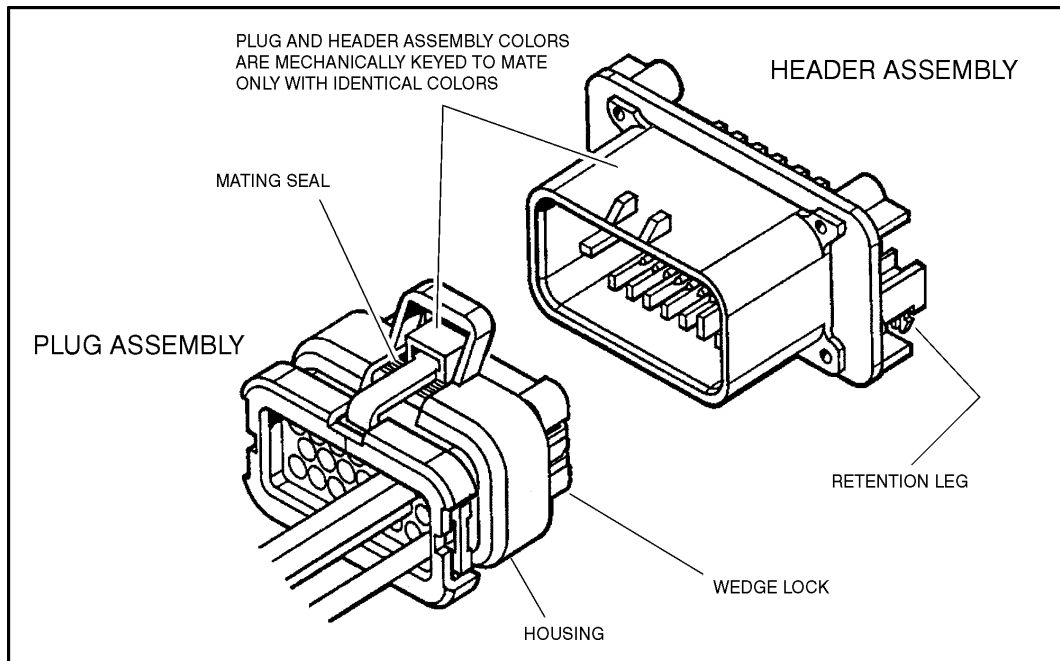

Figure 7-5. AMP Connector

Assembly

Check to be sure the wedge lock is in the open, or as-shipped, position (See Figure 7-6. Connector Assembly (1 of 4)). Proceed as follows:

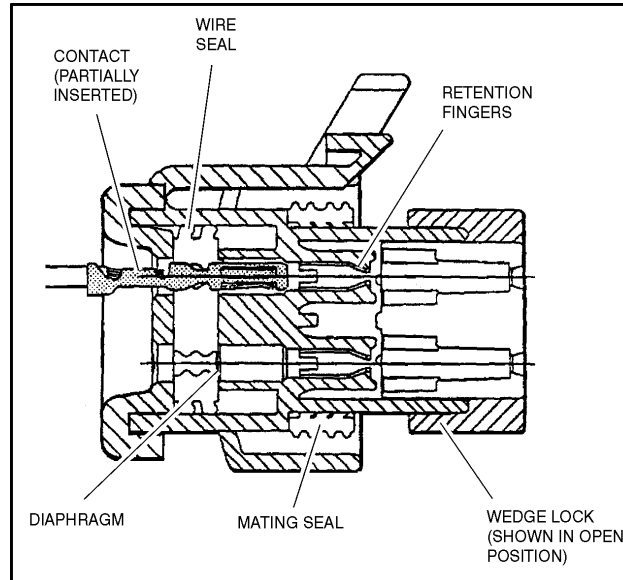

Figure 7-6. Connector Assembly (1 of 4)

1. To insert a contact, push it straight into the appropriate circuit cavity as far as it will go (See Figure 7-7. Connector Assembly (2 of 4)).
2. Pull back on the contact wire with a force of 1 or 2 lb. to be sure the retention fingers are holding the contact (See Figure 7-7. Connector Assembly (2 of 4)).
3. After all required contacts have been inserted, the wedge lock must be closed to its locked position. Release the locking latches by squeezing them inward (See Figure 7-8. Connector Assembly (3 of 4)).
4. Slide the wedge lock into the housing until it is flush with the housing (See Figure 7-9. Connector Assembly (4 of 4)).

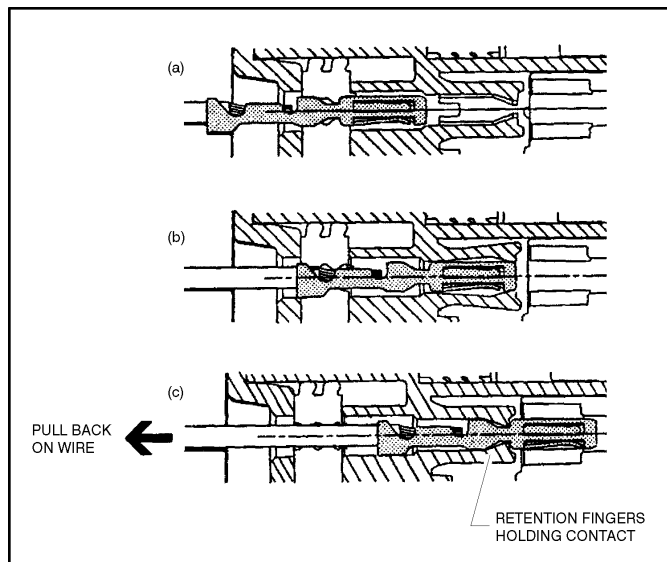

Figure 7-7. Connector Assembly (2 of 4)

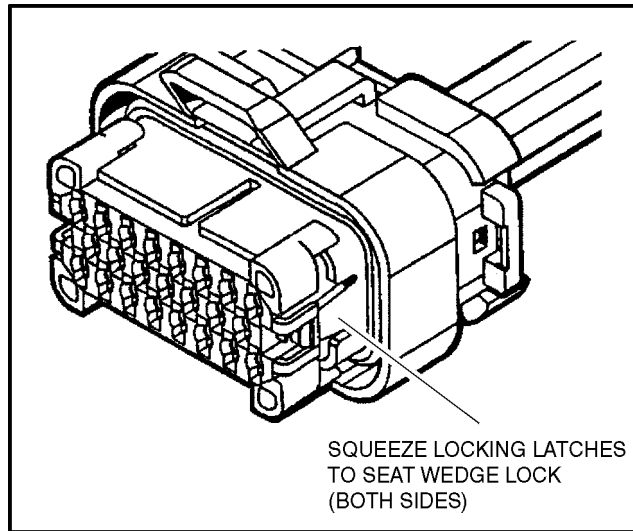

Figure 7-8. Connector Assembly (3 of 4)

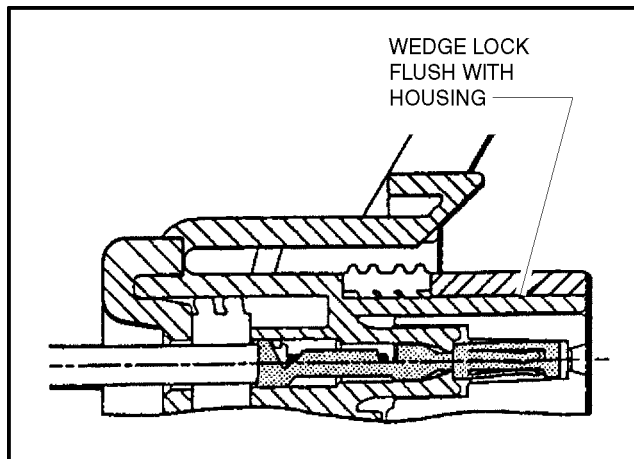

Figure 7-9. Connector Assembly (4 of 4)

Disassembly

5. Insert a 4.8 mm (m3/16") wide screwdriver blade between the mating seal and one of the red wedge lock tabs.
6. Pry open the wedge lock to the open position.
7. While rotating the wire back and forth over a half turn (1/4 turn in each direction), gently pull the wire until the contact is removed.

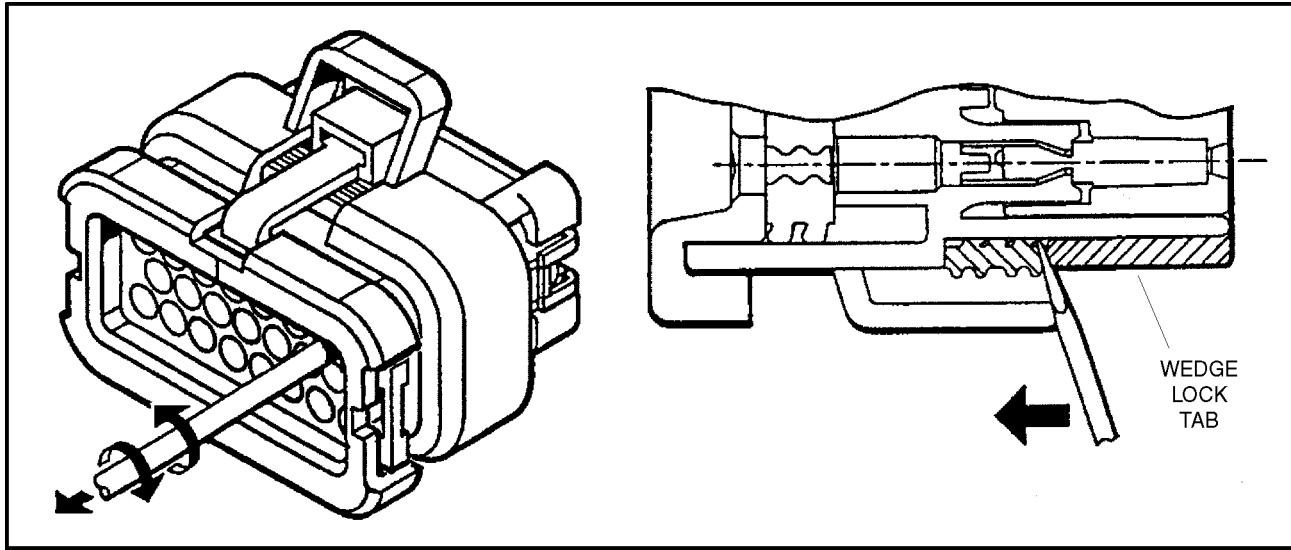

Figure 7-10. Connector Disassembly

NOTE: The wedge lock should never be removed from the housing for insertion or removal of the contacts.

Wedge Lock

The wedge lock has slotted openings in the forward, or mating end. These slots accommodate circuit testing in the field, by using a flat probe such as a pocket knife. DO NOT use a sharp point such as an ice pick.

Service - Voltage Reading

⚠ CAUTION

DO NOT PIERCE WIRE INSULATION TO TAKE VOLTAGE READINGS.

It has been common practice in electrical troubleshooting to probe wires by piercing the insulation with a sharp point. This practice should be discouraged when dealing with the AMPSEAL plug assembly, or any other sealed connector system. The resulting pinholes in the insulation will allow moisture to invade the system by traveling along the wire strands. This nullifies the effectiveness of the connector seals and could result in system failure.

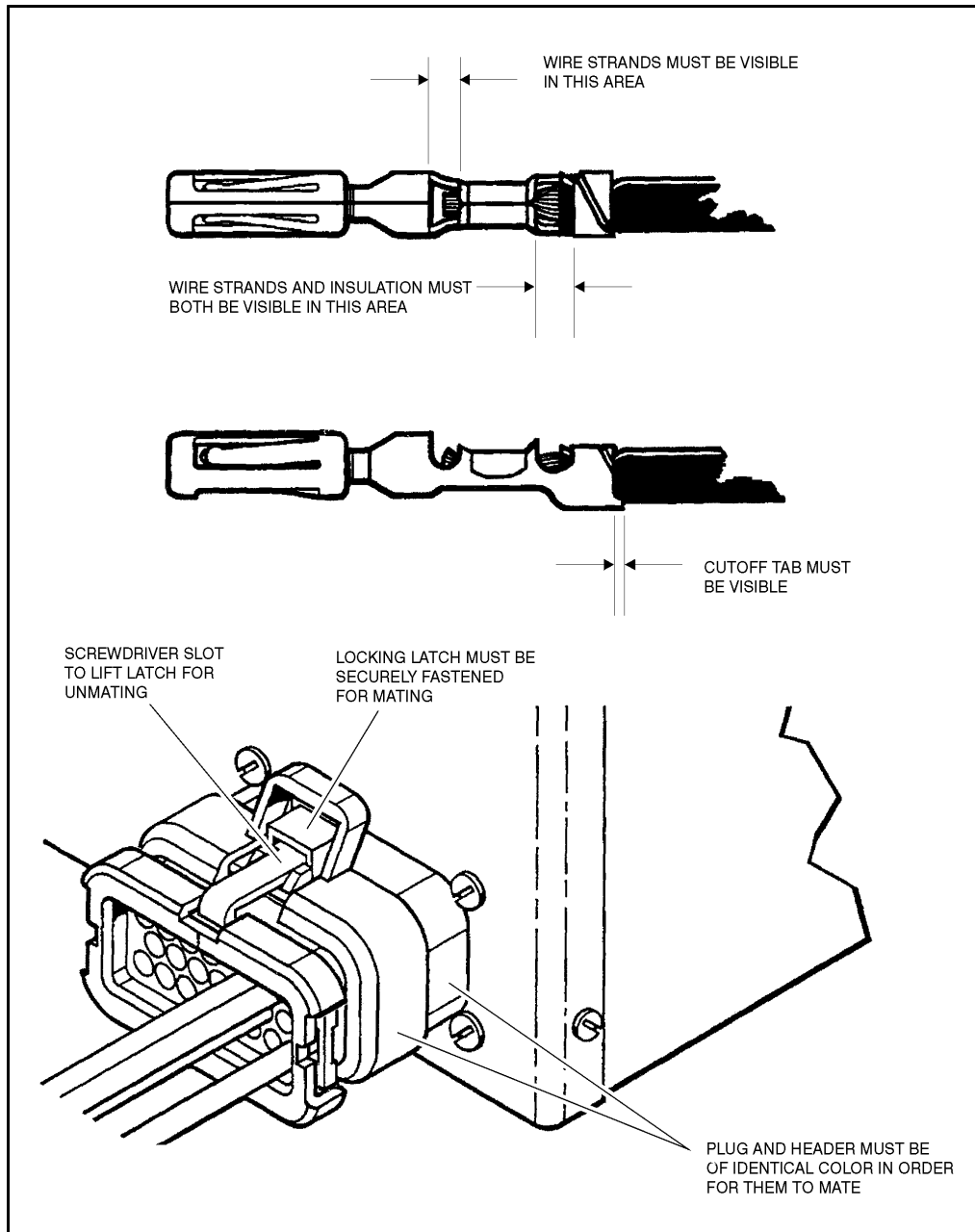

Figure 7-11. Connector Installation

7.4 WORKING WITH DEUTSCH CONNECTORS

DT/DTP Series Assembly

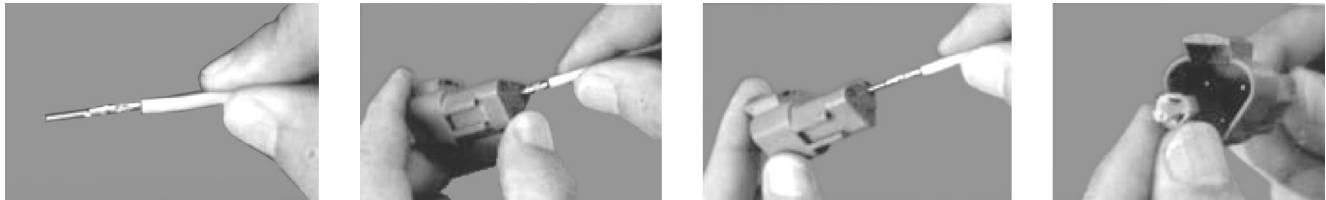

Figure 7-12. DT/DTP Contact Installation

1. Grasp crimped contact about 25mm behind the contact barrel.
2. Hold connector with rear grommet facing you.
3. Push contact straight into connector grommet until a click is felt. A slight tug will confirm that it is properly locked in place.
4. Once all contacts are in place, insert wedgelock with arrow pointing toward exterior locking mechanism. The wedgelock will snap into place. Rectangular wedges are not oriented. They may go in either way.

NOTE: The receptacle is shown - use the same procedure for plug.

DT/DTP Series Disassembly



Figure 7-13. DT/DTP Contact Removal

5. Remove wedgelock using needlenose pliers or a hook shaped wire to pull wedge straight out.
6. To remove the contacts, gently pull wire backwards, while at the same time releasing the locking finger by moving it away from the contact with a screwdriver.
7. Hold the rear seal in place, as removing the contact may displace the seal.

HD30/HDP20 Series Assembly



Figure 7-14. HD/HDP Contact Installation

8. Grasp contact about 25mm behind the contact crimp barrel.
9. Hold connector with rear grommet facing you.

10. Push contact straight into connector grommet until a positive stop is felt. A slight tug will confirm that it is properly locked in place.

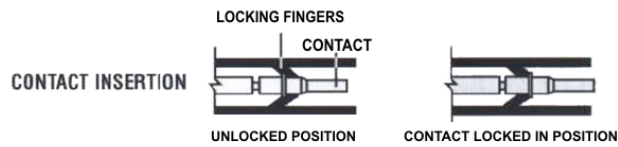

Figure 7-15. HD/HDP Locking Contacts Into Position

NOTE: For unused wire cavities, insert sealing plugs for full environmental sealing

HD30/HDP20 Series Disassembly



Figure 7-16. HD/HDP Contact Removal

11. With rear insert toward you, snap appropriate size extractor tool over the wire of contact to be removed.
12. Slide tool along into the insert cavity until it engages contact and resistance is felt.
13. Pull contact-wire assembly out of connector.

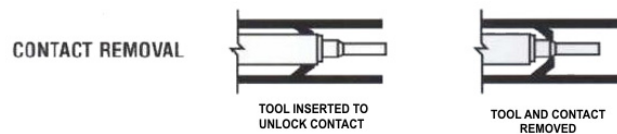

Figure 7-17. HD/HDP Unlocking Contacts

NOTE: Do Not twist or insert tool at an angle.

7.5 SWITCHES

Basic check

The following check determines if the switch is functioning properly, not the circuit in which the switch is placed. A switch is functioning properly when there is continuity between the correct terminals or contacts only when selected.

1. Isolate the switch from the rest of the circuit if possible. If not possible, keep in mind it may affect readings.
2. Access the terminals to the switch.
3. If the switch has two terminals:
 - a. Measure resistance across the terminals.
 - b. Change the switch position.
 - c. Measure resistance again with the leads in the same positions. If the meter was reading short, it should read an open. If the meter was reading open it should read short.
4. If the switch has more than two terminals, consult the schematic or switch diagram to determine what terminals will be connected. The test is similar to testing a switch with two terminals.
 - a. Place one meter lead on the common contact and the other on a different contact in the same circuit.
 - b. Cycle through all positions of the switch. The meter should read short only when the switch connects the two terminals and open otherwise.
 - c. If the switch has more than one common contact repeat the process for that circuit.

Limit Switches

Limit switches are used to control movement or indicate position. Mechanical limit switches are just like manually operated switches except that the moving object operates the switch. These switches can be tested the same way as a standard switch by manually operating the sensing arm.

Another type of limit switch used by JLG is the inductive proximity switch, also referred to as a "prox switch". Inductive proximity switches are actuated only by ferrous metal (metal that contains Iron, such as steel) near the switch. They do not require contact, and must be energized to actuate. These types of switches can be used to detect boom or platform position, for example. These switches have a sensing face where the switch can detect ferrous metal close to it. To find the sensing face, take note how the switch is mounted and how the mechanisms meet the switch. Test this type of switch as follows:

1. Remove prox switch from its mount.
2. Reconnect harness if it was disconnected for step a, and turn on machine.
3. Hold switch away from metal and observe switch state in the control system diagnostics using the Analyzer. See vehicle or control system documentation on how to do this.
4. Place sensing face of switch on the object to be sensed by the switch. If that is not available, use a piece of ferrous metal physically similar to it. The switch state in the control system diagnostics should change.
5. When reinstalling or replacing switch be sure to follow mounting instructions and properly set the gap between the switch and object sensed.

Automatic Switches

If the switch is actuated automatically, by temperature or pressure for example, find a way to manually actuate the switch to test it. Do this either by applying heat or pressure, for example, to the switch. These switches may need to be energized to actuate.

1. Connect instrumentation to monitor and/or control the parameter the switch is measuring.
2. Observe switch state in control system with the Analyzer. See vehicle or control system documentation on how to do this.
3. Operate system such that the switch actuates. This could be going over a certain pressure or temperature, for example. The state indicated in the control system should change

Switch Wiring - Low Side, High Side

When controlling a load, a switch can be wired between the positive side of the power source and the load. This switch is called a "high side" switch. The switch supplies the power to the load. When a switch is wired between the negative side of the power source and the load, it is a "low side" switch. The switch provides the ground to the load.

A low side switch will allow voltage to be present on the load. No power is applied because the switch is stopping current flow. This voltage can be seen if the measurement is taken with one test lead on the load and the other on the battery negative side or grounded to the vehicle. What is actually being measured is the voltage drop across the switch. This could mislead a technician into thinking the load is receiving power but not operating. To produce an accurate picture of power or voltage applied to the load, measure voltage across the load's power terminals. Also, the technician can measure the voltage at both power terminals with respect to battery ground. The difference between those two measurements is the voltage applied to the load.

7.6 CIRCUIT BOARDS: INPUTS AND OUTPUTS

Table 7-1. Power Module - J1 Connector Pin Function

Pin	Function	Type	
1	Spare - Analog Input - EAME - LSS Pressure Switch - 1	Analog	Input
2	Spare - Analog Input - EAME - LSS Pressure Switch - 2	Analog	Input
3	Control for Ground Alarm (PWM)	Digital	Output
4	Positive for Analyzer (+12V)	Power	Output
5	Ground Select (Logic Supply for Ground Mode)	Power	Input
6	Positive for Tilt Sensor (Connect to +BATT)	Power	Output
7	Positive for Ground Alarm (Connect to +BATT)	Power	Output
8	Tilt Sig	Digital	Input
9	Elevation Switch - SW1	Digital	Input
10	Ground Lift Down Switch (High-Sensing)	Digital	Input
11	Elevation Switch - SW2	Digital	Input
12	Spare Negative Reference	Power	Output
13	Positive Main Line Contactor (Connect to GNDS diode OR'd with EMS)	Power	Output
14	Spare Digital Input (High-Sensing)	Digital	Input
15	Spare Digital Input (High-Sensing)	Digital	Input
16	Spare (+5V)	Power	Output
17	Spare (Negative)	Power	Output
18	Elevation Switch - SW2 (Connect to +BATT)	Power	Output
19	Elevation Switch - SW1 (Connect to +BATT)	Power	Output
20	RS-232 Receive	Serial	Input
21	RS-232 Transmit	Serial	Output
22	Negative for Analyzer (Connect to -B)	Power	Output
23	Spare Negative Reference (Connect to -B)	Power	Output
24	Spare Digital Input (High-Sensing)	Digital	Input
25	Brake Release	Digital	Input
26	Charger Interlock (High-Sensing)	Digital	Input
27	Lift UP Switch	Digital	Input
28	Battery Supply from External Relay	Power	Input
29	Positive Left Brake Release (Connect to +BATT)	Power	Output
30	Positive Right Brake Release (Connect to +BATT)	Power	Output
31	Positive Manual Brake Release (Connect to +BATT)	Power	Output
32	Negative Main Line Contactor (Low-Side Driver)	Digital	Output
33	Negative Right Brake Solenoid (Low-Side Driver)	Digital	Output
34	Negative Left Brake Solenoid (Low-Side Driver)	Digital	Output
35	Spare Digital Output (Low-Side Driver) / Digital Input (High-Sensing)	Digital	Output

Table 7-2. Power Module - J2 Connector Pin Function

Pin	Function	Type	
1	Positive Lift/Steer Relays - (Connect to +BATT)	Power	Output
2	Positive Lift Down Valve (High-Side Driver)	Power	Output
3	Lift Select - Platform Switch	Digital	Input
4	Steer Left - Joystick Controller	Digital	Input
5	CANbus Low	Serial	I/O
6	CANbus High	Serial	I/O
7	Joystick Positive Analog Reference (+5V)	Power	Output
8	Platform EMS (Logic Supply for Platform Mode)	Power	Input
9	Negative Steer Left Solenoid Valve (Low-Side Driver)	Digital	Output
10	Joystick Trigger - Pin 2	Digital	Input
11	Platform Horn Switch	Digital	Input
12	Joystick - Steer Right	Digital	Input
13	Drive Select - Platform Switch	Digital	Input
14	Joystick (Connect to -B)	Power	Output
15	CANbus Shield (Connect to -B)	Power	Output
16	Negative Lift Down Valve (Low-Side Driver)	Power	Output
17	Negative Lift Up Solenoid Valve (Low-Side Driver)	Digital	Output
18	Negative Steer Right Solenoid Valve (Low-Side Driver)	Digital	Output
19	Joystick Analog Input (0-5V)	Analog	Input
20	Alarm - Platform Box	Digital	Output
21	Yellow Lamp - Platform Box	Digital	Output
22	Spare	Digital	Output
23	Red Lamp - Platform Box	Digital	Output

This page left blank intentionally

7.7 ELECTRICAL SCHEMATICS AND LAYOUTS

3248RS/10RS, 1932RS/6RS/R6 LSS EQUIPPED MACHINE

SHEET 2: CHASSIS HARNESS
MDI JUMPER
LIFT DOWN JUMPER

SHEET 3: POWER CABLES
PLATFORM CABLE
PLATFORM CONTROL BOX
BATTERY DISCONNECT

SHEET 4: CAN TILT SENSOR

SHEET 1

1001129844-1
MAF074701

Figure 7-18. Electrical Schematic - (Global) - Sheet 1 of 7

SECTION 7 - GENERAL ELECTRICAL INFORMATION & SCHEMATICS

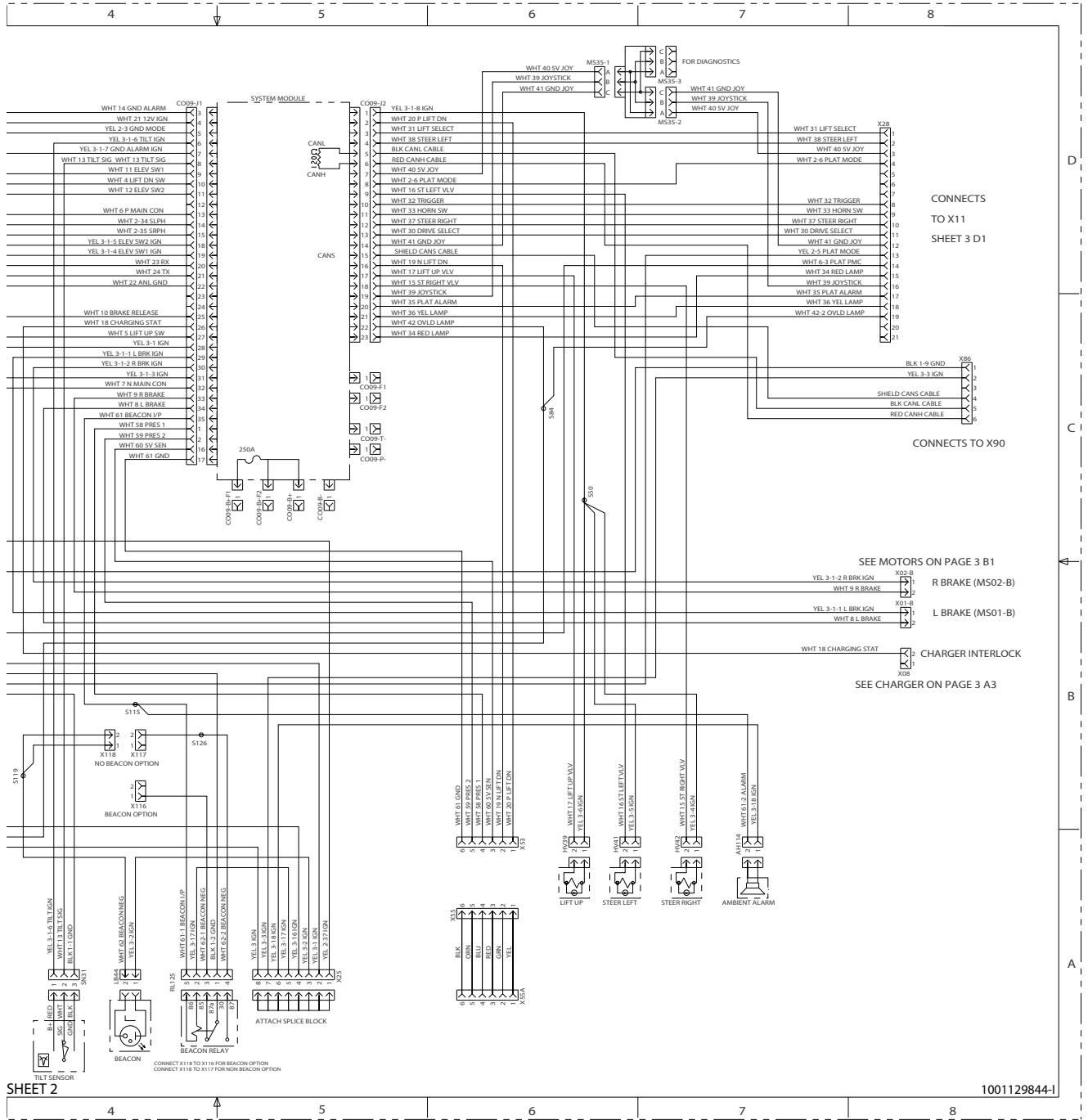

Figure 7-20. Electrical Schematic - (Global) - Sheet 3 of 7

SECTION 7 - GENERAL ELECTRICAL INFORMATION & SCHEMATICS

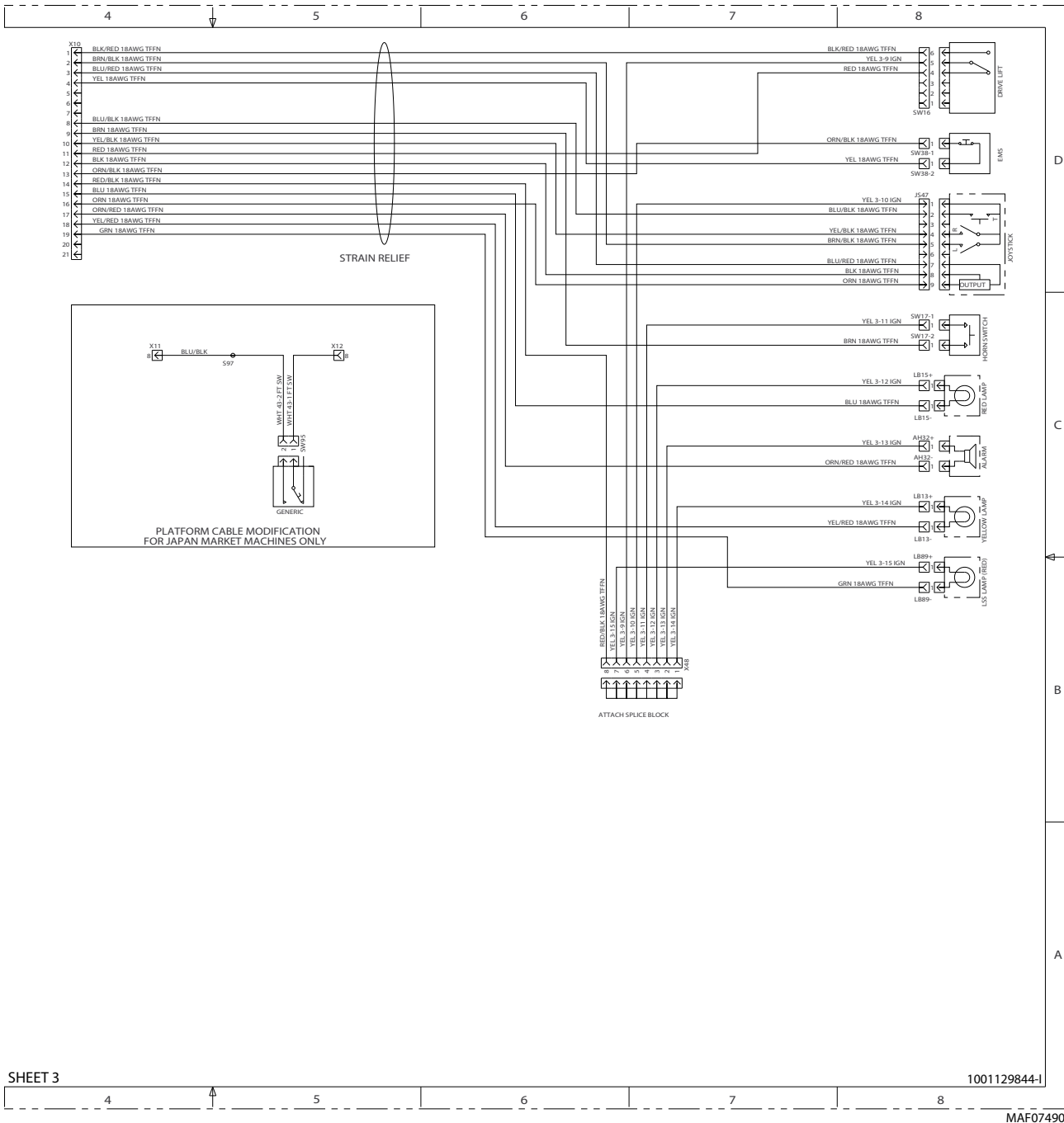

Figure 7-22. Electrical Schematic - (Global) - Sheet 5 of 7

SECTION 7 - GENERAL ELECTRICAL INFORMATION & SCHEMATICS

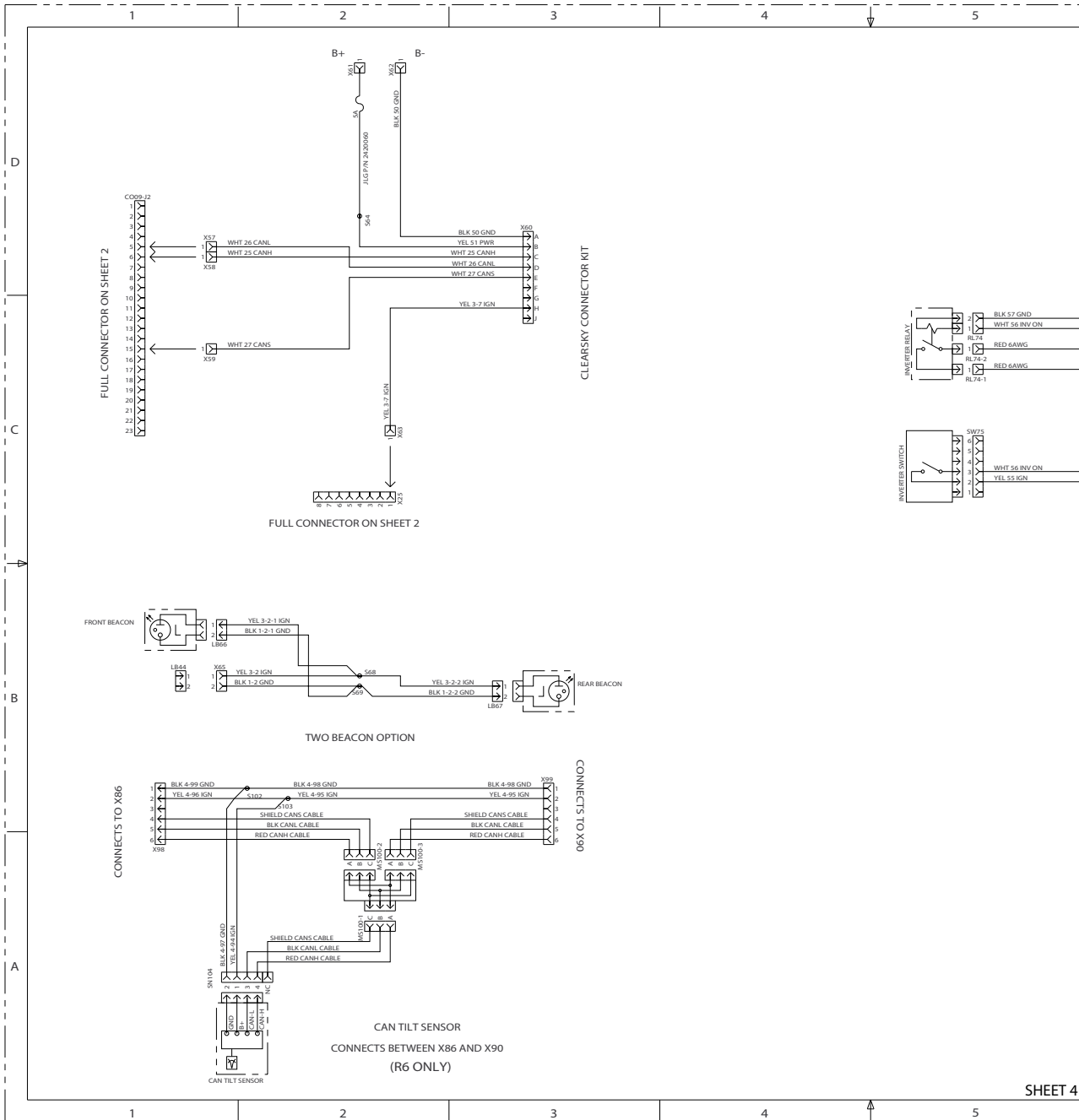

Figure 7-23. Electrical Schematic - (Global) - Sheet 6 of 7

SECTION 7 - GENERAL ELECTRICAL INFORMATION & SCHEMATICS

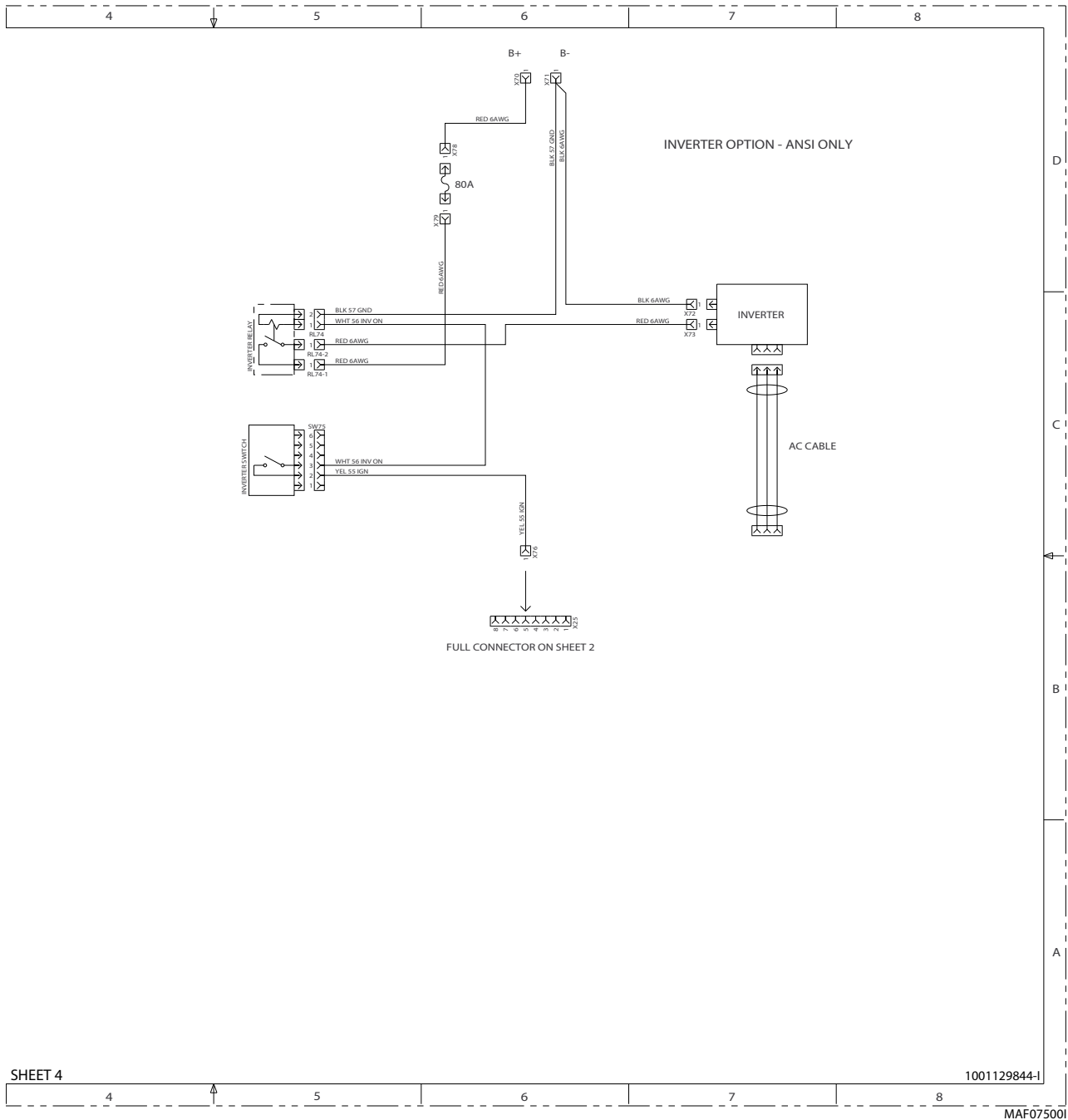

Figure 7-24. Electrical Schematic - (Global) - Sheet 7 of 7

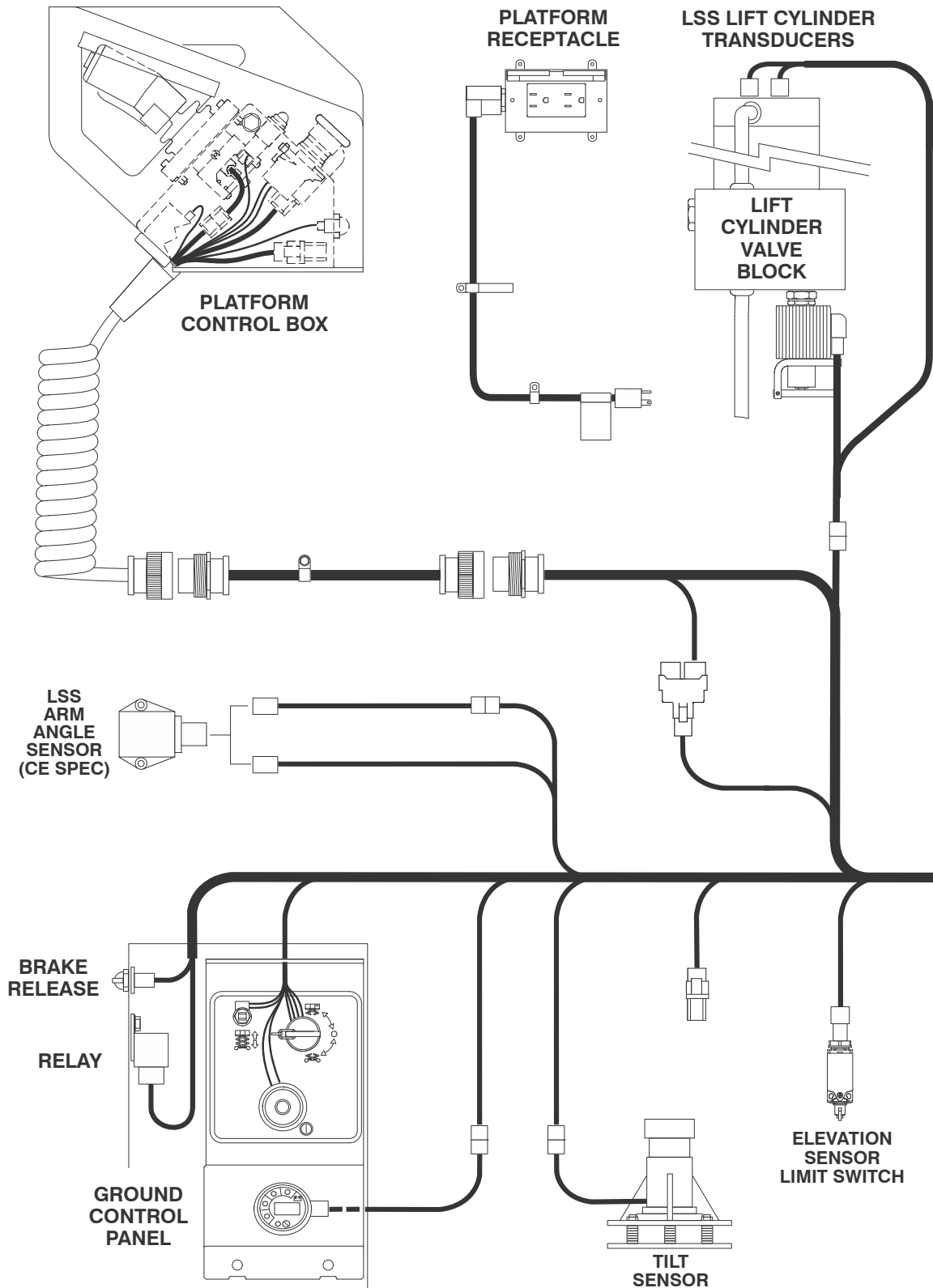

Figure 7-25. Electrical Components Layout - Sheet 1 of 2

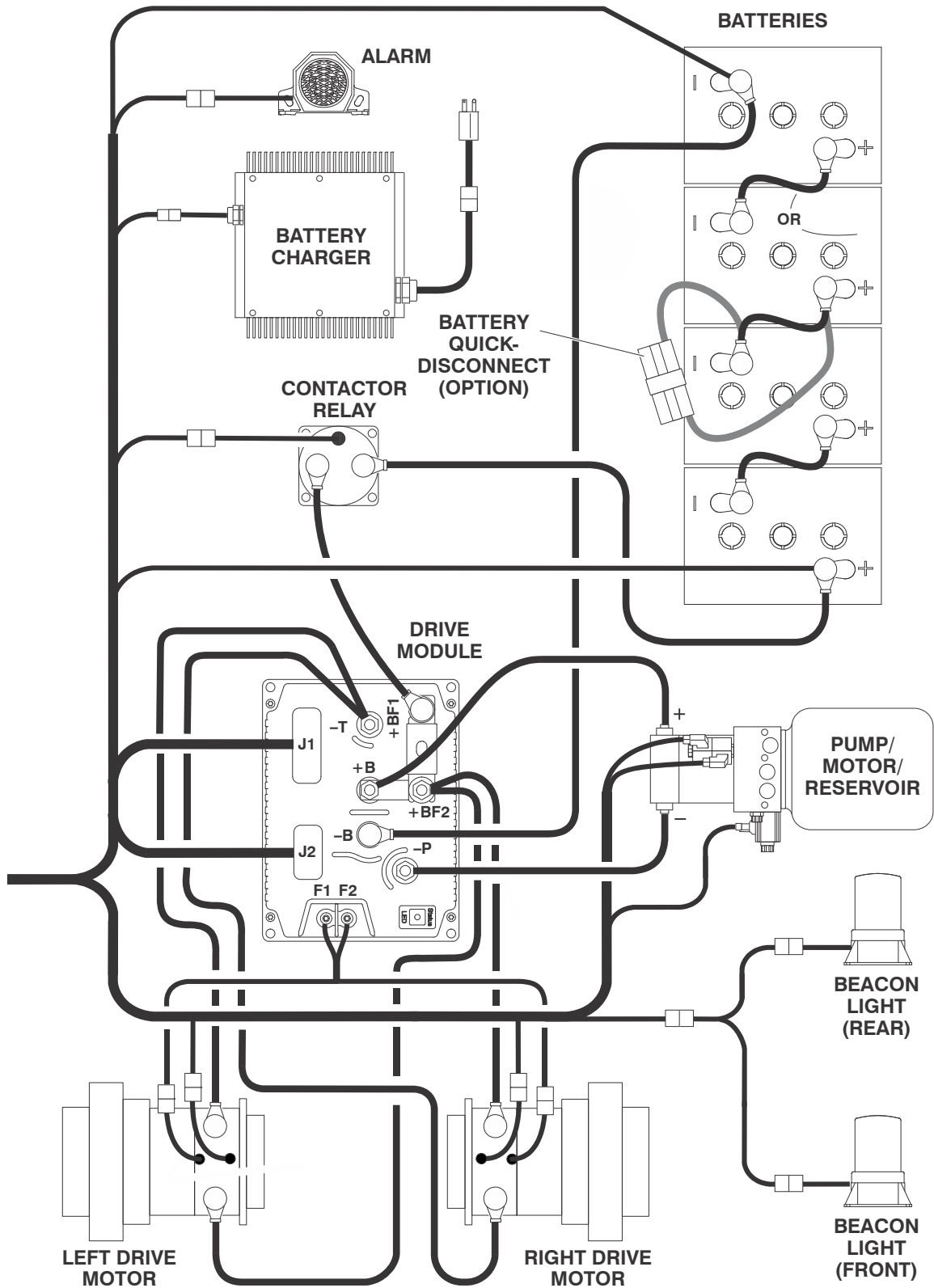

Figure 7-26. Electrical Components Layout - Sheet 2 of 2

7.8 HYDRAULIC SCHEMATIC

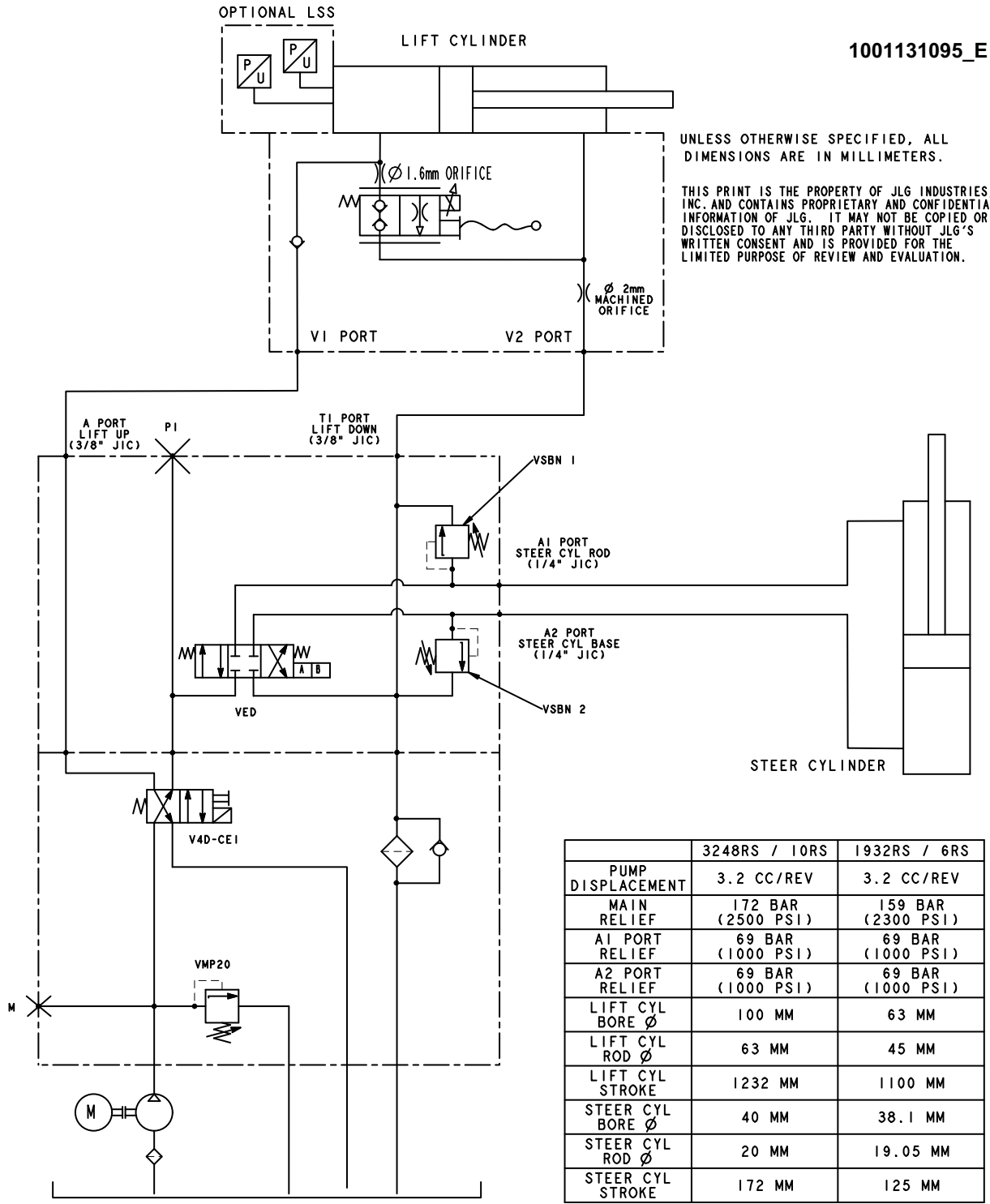

Figure 7-27. Hydraulic Schematic



3121273



An Oshkosh Corporation Company

Corporate Office
JLG Industries, Inc.
1 JLG Drive
McConnellsburg, PA 17233-9533 USA
☎ (717) 485-5161 (Corporate)
☎ (877) 554-5438 (Customer Support)
☎ (717) 485-6417

Visit our website for JLG Worldwide Locations.
www.jlg.com