



An Oshkosh Corporation Company

Operation and Safety Manual

Original Instructions - Keep this manual with the machine at all times.

Model(s)

R6 (AUST)

R6 (ANSI)

R10 (ANSI)

ANSI

P/N - 3121687
September 11, 2015

FOREWORD

This manual is a very important tool! Keep it with the machine at all times.

The purpose of this manual is to provide owners, users, operators, lessors, and lessees with the precautions and operating procedures essential for the safe and proper machine operation for its intended purpose.

Due to continuous product improvements, JLG Industries, Inc. reserves the right to make specification changes without prior notification. Contact JLG Industries, Inc. for updated information.

SAFETY ALERT SYMBOLS AND SAFETY SIGNAL WORDS



This is the Safety Alert Symbol. It is used to alert you to the potential personal injury hazards. Obey all safety messages that follow this symbol to avoid possible injury or death.

⚠ DANGER

INDICATES AN IMMINENTLY HAZARDOUS SITUATION. IF NOT AVOIDED, WILL RESULT IN SERIOUS INJURY OR DEATH. THIS DECAL WILL HAVE A RED BACKGROUND.

⚠ WARNING

INDICATES A POTENTIALITY HAZARDOUS SITUATION. IF NOT AVOIDED, COULD RESULT IN SERIOUS INJURY OR DEATH. THIS DECAL WILL HAVE AN ORANGE BACKGROUND.

⚠ CAUTION

INDICATES A POTENTIALITY HAZARDOUS SITUATION. IF NOT AVOIDED, MAY RESULT IN MINOR OR MODERATE INJURY. IT MAY ALSO ALERT AGAINST UNSAFE PRACTICES. THIS DECAL WILL HAVE A YELLOW BACKGROUND.

NOTICE

INDICATES INFORMATION OR A COMPANY POLICY THAT RELATES DIRECTLY OR INDIRECTLY TO THE SAFETY OF PERSONNEL OR PROTECTION OF PROPERTY.

⚠ WARNING

THIS PRODUCT MUST COMPLY WITH ALL SAFETY RELATED BULLETINS. CONTACT JLG INDUSTRIES, INC. OR THE LOCAL AUTHORIZED JLG REPRESENTATIVE FOR INFORMATION REGARDING SAFETY RELATED BULLETINS WHICH MAY HAVE BEEN ISSUED FOR THIS PRODUCT.

NOTICE

JLG INDUSTRIES, INC. SENDS SAFETY RELATED BULLETINS TO THE OWNER OF RECORD OF THIS MACHINE. CONTACT JLG INDUSTRIES, INC. TO ENSURE THAT THE CURRENT OWNER RECORDS ARE UPDATED AND ACCURATE.

NOTICE

JLG INDUSTRIES, INC. MUST BE NOTIFIED IMMEDIATELY IN ALL INSTANCES WHERE JLG PRODUCTS HAVE BEEN INVOLVED IN AN ACCIDENT INVOLVING BODILY INJURY OR DEATH OF PERSONNEL OR WHEN SUBSTANTIAL DAMAGE HAS OCCURRED TO PERSONAL PROPERTY OR THE JLG PRODUCT.

For:

- Accident Reporting
- Product Safety Publications
- Current Owner Updates
- Questions Regarding Product Safety
- Standards and Regulations Compliance Information
- Questions Regarding Special Product Applications
- Questions Regarding Product Modifications

Contact:

Product Safety and Reliability Department
JLG Industries, Inc.
13224 Fountainhead Plaza
Hagerstown, MD 21742
USA

or Your Local JLG Office
(See addresses on manual rear cover)

In USA:

Toll Free: 877-JLG-SAFE (877-554-7233)

Outside USA:

Phone: 240-420-2661
E-mail: ProductSafety@JLG.com

REVISION LOG

Original Issue of Manual..... January 19, 2015
Manual Revised..... June 4, 2015
(R6 Model Added)
Manual Revised..... September 11, 2015

SECTION - PARAGRAPH, SUBJECT	PAGE
FOREWORD.....	A
SAFETY ALERT SYMBOLS AND SAFETY SIGNAL WORDS.....	B
Contact:	C
In USA:	C
Outside USA:.....	C
REVISION LOG	D
 SECTION - 1 - SAFETY PRECAUTIONS	
1.1 GENERAL	1-1
1.2 PRE-OPERATION	1-2
Operator Training and Knowledge.....	1-2
Workplace Inspection	1-2
Machine Inspection	1-3
1.3 OPERATION.....	1-4
General.....	1-4
Trip and Fall Hazards	1-5
Electrocution Hazards.....	1-6
Tipping Hazards	1-7
Crushing and Collision Hazards.....	1-9
1.4 TOWING, LIFTING, AND HAULING.....	1-11
1.5 MAINTENANCE	1-11
Maintenance Hazards	1-11
Battery Hazards	1-12

SECTION - PARAGRAPH, SUBJECT	PAGE
 SECTION - 2 - USER RESPONSIBILITIES, MACHINE PREPARATION AND INSPECTION	
2.1 PERSONNEL TRAINING	2-1
Operator Training.....	2-1
Training Supervision	2-2
Operator Responsibility	2-2
2.2 PREPARATION, INSPECTION, AND MAINTENANCE.....	2-2
2.3 PRE-START INSPECTION	2-4
2.4 DAILY WALK-AROUND INSPECTION	2-7
2.5 FUNCTION CHECK	2-10
 SECTION - 3 - MACHINE CONTROLS, INDICATORS AND OPERATION	
3.1 GENERAL	3-1
3.2 DESCRIPTION	3-1
3.3 OPERATING CHARACTERISTICS AND LIMITATIONS	3-2
General.....	3-2
Placards	3-2
3.4 PLATFORM LOADING	3-2
3.5 MACHINE CONTROL LOCATIONS	3-3
3.6 BATTERY CHARGING	3-5
Battery Charger Fault (LED Flash)	3-6
3.7 GROUND CONTROL STATION.....	3-7
Ground Emergency Stop Switch	3-8

TABLE OF CONTENTS

SECTION - PARAGRAPH, SUBJECT	PAGE	SECTION - PARAGRAPH, SUBJECT	PAGE
Key Selector Switch	3-8	Lifting	3-26
Platform Lift/Lower Switch	3-8	Tie Down	3-27
MDI-Indicator	3-8	3.14 TOWING	3-29
Overload Indicator (If Equipped)	3-9	Electric Brake Release	3-29
3.8 SCISSOR ARM - SAFETY PROP	3-12	Mechanical Brake Release	3-30
3.9 PLATFORM CONTROL STATION	3-14	SECTION - 4 - EMERGENCY PROCEDURES	
Platform Emergency Stop Switch	3-15	4.1 GENERAL INFORMATION	4-1
Lift/Drive Select	3-15	4.2 EMERGENCY OPERATION	4-1
Forward/Reverse/Lift/Lower Direction Decal	3-15	Operator Unable to Control Machine	4-1
Drive/Lift/Steer Joystick Control	3-16	Platform Caught Overhead	4-1
Steering And Traveling	3-17	Righting of Tipped Machine	4-1
Steering	3-17	4.3 PLATFORM MANUAL DESCENT	4-2
Traveling Forward and Reverse	3-17	4.4 INCIDENT NOTIFICATION	4-3
Raising And Lowering Platform	3-19	SECTION - 5 - GENERAL SPECIFICATIONS AND MAINTENANCE	
Overload Indicator (If Equipped)	3-19	5.1 INTRODUCTION	5-1
Tilt Indicator Warning Light and Alarm	3-19	Other Publications Available Specific to this Machine: ..	5-1
Horn	3-20	5.2 OPERATING SPECIFICATIONS	5-2
Low Battery Charge and System Fault Indicator	3-20	Platform Capacities	5-3
Alarm	3-20	Machine Dimensional Data	5-4
3.10 PLATFORM EXTENSION	3-21	Tires	5-4
3.11 PLATFORM RAILS - FOLD-DOWN PROCEDURE		Batteries	5-4
(R10 ONLY)	3-22	Electrical System	5-5
3.12 PARKING AND STOWING MACHINE	3-24		
Anti-Vandalism Package - Option - (R6 - AUST - Only) ..	3-25		
3.13 MACHINE LIFTING AND TIE DOWN	3-26		

TABLE OF CONTENTS

SECTION - PARAGRAPH, SUBJECT	PAGE	SECTION - PARAGRAPH, SUBJECT	PAGE
5.3 CRITICAL STABILITY WEIGHTS	5-5	2-5 Function Prevented	5-27
5.4 LUBRICATION	5-6	3-1 Line Contactor Open Circuit	5-29
Lubrication Capacities	5-6	3-2 Line Contactor Short Circuit	5-30
Hydraulic Oil	5-6	3-3 Ground Output Driver	5-30
Lubrication Specifications	5-6	4-2 Thermal Limit (SOA)	5-32
5.5 OPERATOR MAINTENANCE	5-8	4-4 Battery Supply	5-32
Hydraulic Oil Check Procedure	5-8	6-6 Communication	5-33
5.6 BATTERY MAINTENANCE	5-9	7-7 Electric Motor	5-33
Battery Maintenance and Safety Practices	5-9	8-1 Tilt Sensor	5-35
Battery Quick-Disconnect - (If Equipped)	5-10	8-2 LSS - Load Sensing System	5-35
5.7 TIRES AND WHEELS	5-10	8-4 Elevation Switch	5-36
Tire Wear and Damage	5-10	9-9 Hardware	5-37
Wheel and Tire Replacement	5-10		
Wheel Installation	5-11		
5.8 SUPPLEMENTAL INFORMATION	5-12		
5.9 DECAL INSTALLATION	5-14		
5.10 DIAGNOSTIC TROUBLE CODES (DTC)	5-22		
5.11 DTC CHECK TABLE INDEX	5-22		
5.12 DIAGNOSTIC TROUBLE CODES (DTC) CHECK TABLES	5-23		
0-0 Help Comments	5-23		
2-1 Power-Up	5-24		
2-2 Platform Controls	5-25		
2-3 Ground Controls	5-26		
2-4 Low/High Temperature Cutout	5-27		
		SECTION - 6 - INSPECTION AND REPAIR LOG	

TABLE OF CONTENTS

SECTION - PARAGRAPH, SUBJECT	PAGE	SECTION - PARAGRAPH, SUBJECT	PAGE
LIST OF FIGURES			
2-1. R6 - Daily Walk-Around Inspection	2-8	3-20. Brake - Manual Disengage.	3-30
2-2. R10 - Daily Walk-Around Inspection	2-9	4-1. R6 - Location of Manual Descent Control	4-2
2-3. R6- Machine Limit Switch Location	2-12	4-2. R10 - Location of Manual Descent Control	4-3
2-4. R10 - Machine Limit Switch Location	2-13	5-1. R6 - Hydraulic Oil Check Procedure	5-8
3-1. R6 - Location of Machine Controls.....	3-3	5-2. R10 - Hydraulic Oil Check Procedure	5-9
3-2. R10 - Location of Machine Controls.....	3-4	5-3. Battery Fluid Level.....	5-10
3-3. Charger Decal LED Indicators	3-5	5-4. Wheel Lug Nut Tightening Sequence	5-12
3-4. Ground Control Station.....	3-7	5-5. R6 (AUST) - Machine Decal Installation	5-14
3-5. MDI Indicator	3-9	5-6. R6 (ANSI) - Machine Decal Installation.....	5-16
3-6. R6 - Location of Manual Descent Control	3-10	5-7. R10 (ANSI) - Machine Decal Installation	5-19
3-7. R10 - Location of Manual Descent Control.....	3-11		
3-8. R6 - Scissor Arm - Safety Prop.....	3-13		
3-9. R10 - Scissor Arm - Safety Prop.....	3-13		
3-10. Platform Control Station	3-14		
3-11. Platform Control Components.....	3-16		
3-12. Grade and Sideslope Definition	3-18		
3-13. R6/R10 - Platform Deck Extension.....	3-21		
3-14. R10 - Platform Rails - Fold Down Sequence.....	3-23		
3-15. Securing Control Station to Platform.....	3-24		
3-16. Fork Lift Pockets - Location	3-26		
3-17. R6/R10 - Lifting Machine Using Spreader Bar and Lift Lug Locations	3-27		
3-18. R6/R10 - Tie Down and Lift Lug Locations	3-28		
3-19. R6/R10 - Electric Brake Release - Location	3-29		

SECTION - PARAGRAPH, SUBJECT	PAGE	SECTION - PARAGRAPH, SUBJECT	PAGE
LIST OF TABLES			
1-1	Minimum Approach Distances (M.A.D.).....	1-7	
1-2	Beaufort Scale (For Reference Only)	1-8	
2-1	Inspection and Maintenance Table.....	2-3	
2-2	High Drive Cutout Height.....	2-11	
2-3	Tilt Activation Setting.....	2-11	
3-1	Battery Charger Fault (LED Flash).....	3-6	
5-1	Operating Specifications.....	5-2	
5-2	Platform Capacities.....	5-3	
5-3	Dimensions	5-4	
5-4	Tire Specifications	5-4	
5-5	Battery Specifications.....	5-4	
5-6	Electrical System Specifications	5-5	
5-7	Critical Stability Weights	5-5	
5-8	Capacities	5-6	
5-9	Hydraulic Oil	5-6	
5-10	Lubrication Specifications.....	5-6	
5-11	Hydraulic Oil Specifications	5-7	
5-12	Wheel Torque Chart	5-12	
5-13	R6 (AUST) - Machine Decal Installation Chart.....	5-15	
5-14	R6 (ANSI) - Machine Decal Installation Chart	5-17	
5-15	R10 (ANSI) - Machine Decal Installation Chart.....	5-20	
6-1	Inspection and Repair Log	6-1	

SECTION 1. SAFETY PRECAUTIONS

1.1 GENERAL

This section outlines the necessary precautions for proper and safe machine usage and maintenance. In order to promote proper machine usage, it is mandatory that a daily routine is established based on the content of this manual. A maintenance program, using the information provided in this manual and the Service and Maintenance Manual, must also be established by a qualified person and must be followed to ensure that the machine is safe to operate.

The owner/user/operator/lessor/lessee of the machine must not accept operating responsibility until this manual has been read, training is accomplished, and operation of the machine has been completed under the supervision of an experienced and qualified operator.

These sections contain the responsibilities of the owner, user, operator, lessor, and lessee concerning safety, training, inspection, maintenance, application, and operation. If there are any questions with regard to safety, training, inspection, maintenance, application, and operation, please contact JLG Industries, Inc. ("JLG").

WARNING

FAILURE TO COMPLY WITH THE SAFETY PRECAUTIONS LISTED IN THIS MANUAL COULD RESULT IN MACHINE DAMAGE, PROPERTY DAMAGE, PERSONAL INJURY OR DEATH.

1.2 PRE-OPERATION

Operator Training and Knowledge

- The Operation and Safety Manual must be read and understood in its entirety before operating the machine. For clarification, questions, or additional information regarding any portions of this manual, contact JLG Industries, Inc.

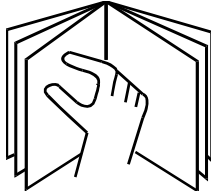

- An operator must not accept operating responsibilities until adequate training has been given by competent and authorized persons.
- Allow only those authorized and qualified personnel to operate the machine who have demonstrated that they understand the safe and proper operation and maintenance of the unit.
- Read, understand, and obey all DANGERS, WARNINGS, CAUTIONS, and operating instructions on the machine and in this manual.

- Ensure that the machine is to be used in a manner which is within the scope of its intended application as determined by JLG.
- All operating personnel must be familiar with the emergency controls and emergency operation of the machine as specified in this manual.
- Read, understand, and obey all applicable employer, local, and governmental regulations as they pertain to your utilization and application of the machine.

Workplace Inspection

- Precautions to avoid all hazards in the work area must be taken by the user before and during operation of the machine.
- Do not operate or raise the platform from a position on trucks, trailers, railway cars, floating vessels, scaffolds or other equipment unless the application is approved in writing by JLG.
- Before operation, check work area for overhead hazards such as electric lines, bridge cranes, and other potential overhead obstructions.
- Check floor surfaces for holes, bumps, drop-offs, obstructions, debris, concealed holes, and other potential hazards.

- Check the work area for hazardous locations. Do not operate the machine in hazardous environments unless approved for that purpose by JLG.
- Ensure that the ground conditions are adequate to support the maximum tire load indicated on the tire load decals located on the chassis adjacent to each wheel.
- This machine can be operated in nominal ambient temperatures of 0° F to 104° F (-20° C to 40° C). Consult JLG to optimize operation outside of this temperature range.
- Do not operate any machine on which the safety or instruction placards or decals are missing or illegible.
- Check the machine for modifications to original components. Ensure that any modifications have been approved by JLG.
- Avoid accumulation of debris on platform deck. Keep mud, oil, grease, and other slippery substances from footwear and platform deck.

Machine Inspection

- Do not operate this machine until the inspections and functional checks have been performed as specified in Section 2 of this manual.
- Do not operate this machine until it has been serviced and maintained according to the maintenance and inspection requirements as specified in the machine's Service and Maintenance Manual.
- Ensure all safety devices are operating properly. Modification of these devices is a safety violation.

WARNING

MODIFICATION OR ALTERATION OF AN AERIAL WORK PLATFORM SHALL BE MADE ONLY WITH PRIOR WRITTEN PERMISSION FROM THE MANUFACTURER.

SECTION 1 - SAFETY PRECAUTIONS

1.3 OPERATION

General

- Machine operation requires your full attention. Bring the machine to a full stop before using any device, i.e. cell phones, two-way radios, etc. that will distract your attention from safely operating the machine.
 - Do not use the machine for any purpose other than positioning personnel, their tools, and equipment.
 - Before operation, the user must be familiar with the machine capabilities and operating characteristics of all functions.
 - Never operate a malfunctioning machine. If a malfunction occurs, shut down the machine. Remove the unit from service and notify the proper authorities.
 - Do not remove, modify, or disable any safety devices.
 - Never slam a control switch or lever through neutral to an opposite direction. Always return switch to neutral and stop before moving the switch to the next function. Operate controls with slow and even pressure.
 - Do not allow personnel to tamper with or operate the machine from the ground with personnel in the platform, except in an emergency.
- Do not carry materials directly on platform railing unless approved by JLG.
 - When two or more persons are in the platform, the operator shall be responsible for all machine operations.
 - Always ensure that power tools are properly stowed and never left hanging by their cord from the platform work area.
 - Do not assist a stuck or disabled machine by pushing or pulling except by pulling at the chassis tie-down lugs.
 - Fully lower platform and shut off all power before leaving machine.
 - Remove all rings, watches, and jewelry when operating machine. Do not wear loose fitting clothing or long hair unrestrained which may become caught or entangled in equipment.
 - Persons under the influence of drugs or alcohol or who are subject to seizures, dizziness or loss of physical control must not operate this machine.

Trip and Fall Hazards

- Prior to operation, ensure all gates and rails are fastened and secured in their proper position.

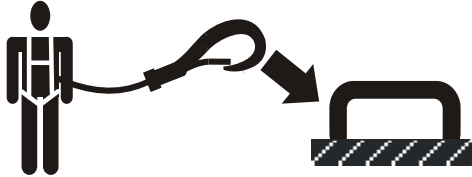

- JLG Industries, Inc. recommends that all persons in the platform wear a full body harness with a lanyard attached to an authorized lanyard anchorage point while operating this machine. For further information regarding fall protection requirements on JLG products, contact JLG Industries, Inc.
- Identify the designated lanyard anchorage point(s) at the platform and securely attach the lanyard. Attach only one (1) lanyard per lanyard anchorage point.
- Enter and exit only through gate area. Use extreme caution when entering or leaving platform. Ensure that the platform assembly is fully lowered. Face the machine when entering or leaving the platform. Always maintain “three point contact” with the machine, using two hands and one foot or two feet and one hand at all times during entry and exit.

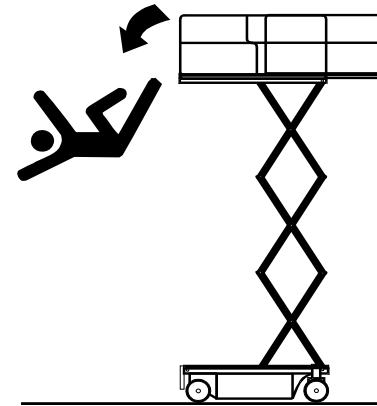

- Keep both feet firmly positioned on the platform floor at all times. Never position ladders, boxes, steps, planks, or similar items on unit to provide additional reach for any purpose.
- Never use the scissor arm assembly to gain access to or leave the platform.
- Keep oil, mud, and slippery substances cleaned from footwear and the platform floor.

Electrocution Hazards

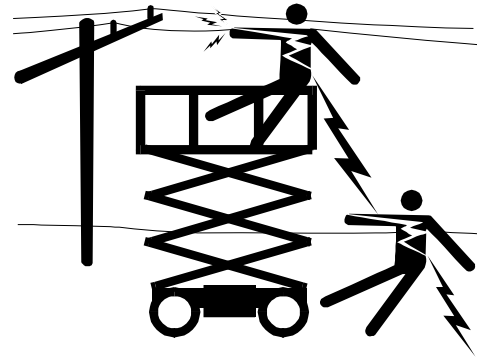
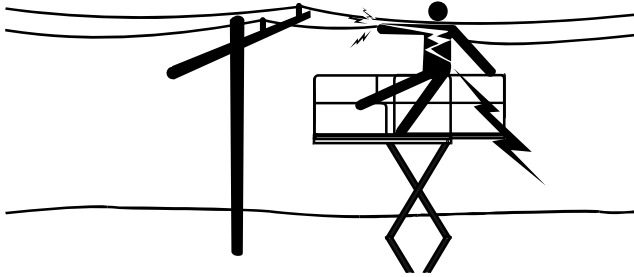

- This machine is not insulated and does not provide protection from contact or proximity to electrical current.
 - Maintain distance from electrical lines, apparatus, or any energized (exposed or insulated) parts according to the Minimum Approach Distance (MAD) as shown in Table 1-1.
 - Allow for machine movement and electrical line swaying.
 - Maintain a clearance of at least 10 ft. (3m) between any part of the machine and its occupants, their tools, and their equipment from any electrical line or apparatus carrying up to 50,000 volts. One foot additional clearance is required for every additional 30,000 volts or less.
- The minimum approach distance may be reduced if insulating barriers are installed to prevent contact, and the barriers are rated for the voltage of the line being guarded. These barriers shall not be part of (or attached to) the machine. The minimum approach distance shall be reduced to a distance within the designed working dimensions of the insulating barrier. This determination shall be made by a qualified person in accordance with the employer, local, or governmental requirements for work practices near energized equipment.



DO NOT MANEUVER MACHINE OR PERSONNEL INSIDE PROHIBITED ZONE (MAD). ASSUME ALL ELECTRICAL PARTS AND WIRING ARE ENERGIZED UNLESS KNOWN OTHERWISE.

Table 1-1. Minimum Approach Distances (M.A.D.)

VOLTAGE RANGE (Phase to Phase)	MINIMUM APPROACH DISTANCE in Feet (Meters)
0 to 50 KV	10 (3)
Over 50KV to 200 KV	15 (5)
Over 200 KV to 350 KV	20 (6)
Over 350 KV to 500 KV	25 (8)
Over 500 KV to 750 KV	35 (11)
Over 750 KV to 1000 KV	45 (14)
NOTE: <i>This requirement shall apply except where employer, local or governmental regulations are more stringent.</i>	

Tipping Hazards

- Ensure that the ground conditions are adequate to support the maximum tire load indicated on the tire load decals located on the chassis adjacent to each wheel. Do not travel on unsupported surfaces.
- The user must be familiar with the driving surface before driving. Do not exceed the allowable sideslope and grade while driving.
- Do not elevate platform or drive with platform elevated while on or near a sloping, uneven, or soft surface. Ensure machine is positioned on a firm, level and smooth surface before elevating platform or driving with the platform in the elevated position.
- Before driving on floors, bridges, trucks, and other surfaces, check allowable capacity of the surfaces.
- Never exceed the maximum work load as specified on the platform. Keep all loads within the confines of the platform, unless authorized by JLG.
- Keep the chassis of the machine a minimum of 2 ft. (0.6m) from holes, bumps, drop-offs, obstructions, debris, concealed holes, and other potential hazards at the ground level.
- Do not operate the machine when wind conditions exceed specifications shown in Section 5, Table 5-2 or as shown on the capacity placard on the platform billboard.

SECTION 1 - SAFETY PRECAUTIONS

WARNING

DO NOT OPERATE THE MACHINE WHEN WIND CONDITIONS EXCEED SPECIFICATIONS SHOWN IN SECTION 5, TABLE 5-2 OR AS SHOWN ON THE CAPACITY PLACARD ON THE PLATFORM BILLBOARD.

Table 1-2. Beaufort Scale (For Reference Only)

BEAUFORT NUMBER	WIND SPEED		DESCRIPTION	LAND CONDITIONS
	mph	m/s		
0	0	0-0.2	Calm	Calm. Smoke rises vertically.
1	1-3	0.3-1.5	Light air	Wind motion visible in smoke.
2	4-7	1.6-3.3	Light breeze	Wind felt on exposed skin. Leaves rustle.
3	8-12	3.4-5.4	Gentle breeze	Leaves and smaller twigs in constant motion.
4	13-18	5.5-7.9	Moderate breeze	Dust and loose paper raised. Small branches begin to move.
5	19-24	8.0-10.7	Fresh breeze	Smaller trees sway.
6	25-31	10.8-13.8	Strong breeze	Large branches in motion. Flags waving near horizontal. Umbrella use becomes difficult.
7	32-38	13.9-17.1	Near Gale/Moderate Gale	Whole trees in motion. Effort needed to walk against the wind.
8	39-46	17.2-20.7	Fresh Gale	Twigs broken from trees. Cars veer on road.
9	47-54	20.8-24.4	Strong Gale	Light structure damage.

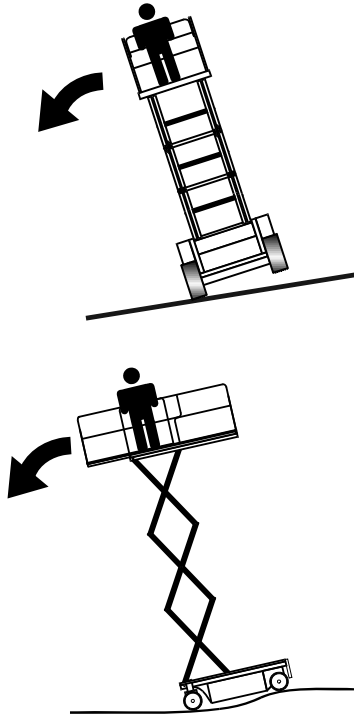

- Never attempt to use the machine as a crane. Do not tie-off machine to any adjacent structure. Never attach wire, cable, or any similar items to platform.
- Do not cover the platform sides or carry large surface-area items in the platform when operating outdoors. The addition of such items increases the exposed wind area of the machine.
- Do not increase the platform size with unauthorized deck extensions or attachments.
- If the scissor arm assembly or platform is caught so that one or more wheels are off the ground, all persons must be removed before attempting to free the machine. Use cranes, forklift trucks, or other appropriate equipment to stabilize machine and remove personnel.

Crushing and Collision Hazards

- Approved head gear must be worn by all operating and ground personnel.
- Keep hands and limbs out of the scissor arm assembly during operation and when elevated without safety prop engaged.
- Watch for obstructions around machine and overhead when driving. Check clearances above, on sides, and bottom of platform when lifting or lowering platform.

SECTION 1 - SAFETY PRECAUTIONS

- During operation, keep all body parts inside platform railing.

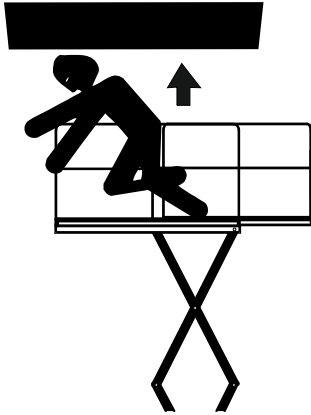

- Always post a lookout when driving in areas where vision is obstructed.
- Keep non-operating personnel at least 6 ft. (1.8m) away from machine during all operations.
- Under all travel conditions, the operator must limit travel speed according to conditions of ground surface, congestion, visibility, slope, location of personnel, and other factors.

- Be aware of stopping distances in all drive speeds. When driving in high speed, switch to low speed before stopping. Travel grades in low speed only.
- Do not use high speed drive in restricted or close quarters or when driving in reverse.
- Exercise extreme caution at all times to prevent obstacles from striking or interfering with operating controls and persons in the platform.
- Ensure that operators of other overhead and floor level machines are aware of the aerial work platform's presence. Disconnect power to overhead cranes. Barricade floor area if necessary.
- Do not operate over ground personnel. Warn personnel not to work, stand, or walk under a raised platform. Position barricades on floor as necessary.

1.4 TOWING, LIFTING, AND HAULING

- Never allow personnel in platform while towing, lifting, or hauling.
- This machine should not be towed, except in the event of emergency, malfunction, power failure, or loading/unloading. Refer to emergency towing procedures.
- Ensure platform is fully retracted and completely empty of tools prior to towing, lifting or hauling.
- When lifting machine with a forklift, position forks only at designated areas of the machine. Lift with a forklift of adequate capacity.
- Refer to Section 3 for lifting information.

1.5 MAINTENANCE

This sub-section contains general safety precautions which must be observed during maintenance of this machine. Additional precautions to be observed during machine maintenance are inserted at the appropriate points in this manual and in the Service and Maintenance Manual. It is of utmost importance that maintenance personnel pay strict attention to these precautions to avoid possible injury to personnel or damage to the machine or property. A maintenance program

must be established by a qualified person and must be followed to ensure that the machine is safe.

Maintenance Hazards

- Shut off power to all controls and ensure that all moving parts are secured from inadvertent motion prior to performing any adjustments or repairs.
- Never work under an elevated platform until it has been fully lowered to the full down position, if possible, or otherwise supported and restrained from movement with appropriate safety props, blocking, or overhead supports.
- DO NOT attempt to repair or tighten any hydraulic hoses or fittings while the machine is powered on or when the hydraulic system is under pressure.
- Always relieve hydraulic pressure from all hydraulic circuits before loosening or removing hydraulic components.
- DO NOT use your hand to check for leaks. Use a piece of cardboard or paper to search for leaks. Wear gloves to help protect hands from spraying fluid.
- Ensure replacement parts or components are identical or equivalent to original parts or components.



SECTION 1 - SAFETY PRECAUTIONS

- Never attempt to move heavy parts without the aid of a mechanical device. Do not allow heavy objects to rest in an unstable position. Ensure adequate support is provided when raising components of the machine.
- Use only approved non-flammable cleaning solvents.
- Do not replace items critical to stability, such as batteries or solid tires, with items of different weight or specification. Do not modify unit in any way to affect stability.
- Reference the Service and Maintenance Manual for the weights of critical stability items.

WARNING

MODIFICATION OR ALTERATION OF AN AERIAL WORK PLATFORM SHALL BE MADE ONLY WITH PRIOR WRITTEN PERMISSION FROM THE MANUFACTURER.

Battery Hazards

- Always disconnect batteries when servicing electrical components or when performing welding on the machine.
- Do not allow smoking, open flame, or sparks near battery during charging or servicing.
- Do not contact tools or other metal objects across the battery terminals.
- Always wear hand, eye, and face protection when servicing batteries. Ensure that battery acid does not come in contact with skin or clothing.

CAUTION

BATTERY FLUID IS HIGHLY CORROSIVE. AVOID CONTACT WITH SKIN AND CLOTHING AT ALL TIMES. IMMEDIATELY RINSE ANY CONTACTED AREA WITH CLEAN WATER AND SEEK MEDICAL ATTENTION.

- Charge batteries only in a well ventilated area.
- Avoid overfilling the battery fluid level. Add distilled water to batteries only after the batteries are fully charged.

SECTION 2. USER RESPONSIBILITIES, MACHINE PREPARATION AND INSPECTION

2.1 PERSONNEL TRAINING

The aerial platform is a personnel handling device; so it is necessary that it be operated and maintained only by trained personnel.

Operator Training

Operator training must cover:

- Use and limitations of the controls in the platform and at the ground, emergency controls and safety features.
- Control labels, instructions, and warnings on the machine.
- Rules of the employer and government regulations.
- Use of approved fall protection equipment.
- Enough knowledge of the mechanical operation of the machine to recognize a malfunction or potential malfunction.
- The safest means to operate the machine where overhead obstructions, other moving equipment, and obstacles, depressions, holes, and drop-offs exist.
- Means to avoid the hazards of unprotected electrical conductors.
- Specific job requirements or machine application.
- Reading and understanding the Operation and Safety Manual.

Training Supervision

Training must be done under the supervision of a qualified person in an open area free of obstructions until the trainee has developed the ability to safely control and operate the machine.

Operator Responsibility

The operator must be instructed that he/she has the responsibility and authority to shut down the machine in case of a malfunction or other unsafe condition of either the machine or the job site.

NOTE: *The Manufacturer or Distributor will provide qualified people for training assistance with the first unit(s) delivered and from that time forward as requested by the user or his/her personnel.*

2.2 PREPARATION, INSPECTION, AND MAINTENANCE

Table 2-1 explains the periodic machine inspections and maintenance recommended by JLG Industries, Inc. Consult local regulations for further requirements for aerial work platforms. The frequency of inspections and maintenance must be increased as necessary when the machine is used in a harsh or hostile environment, if the machine is used with increased frequency, or if the machine is used in a severe manner.

SECTION 2 - USER RESPONSIBILITIES, MACHINE PREPARATION AND INSPECTION

Table 2-1. Inspection and Maintenance Table

TYPE	FREQUENCY	PRIMARY RESPONSIBILITY	SERVICE QUALIFICATION	REFERENCE
Pre-Start Inspection	Before using each day; or whenever there's an Operator change.	User or Operator	User or Operator	Operation and Safety Manual
Pre-Delivery Inspection <i>(see note below)</i>	Before each sale, lease, or rental delivery.	Owner, Dealer, or User	Qualified JLG Mechanic	Service and Maintenance Manual and applicable JLG inspection form
Frequent Inspection	In service for 3 months or 150 hours, whichever comes first; or Out of service for a period of more than 3 months; or Purchased used.	Owner, Dealer, or User	Qualified JLG Mechanic	Service and Maintenance Manual and applicable JLG inspection form
Annual Machine Inspection <i>(see note below)</i>	Annually, no later than 13 months from the date of prior inspection.	Owner, Dealer, or User	Factory Trained Service Technician (Recommended)	Service and Maintenance Manual and applicable JLG inspection form
Preventative Maintenance	At intervals as specified in the Service and Maintenance Manual.	Owner, Dealer, or User	Qualified JLG Mechanic	Service and Maintenance Manual

NOTE: Inspection forms are available from JLG. Use the Service and Maintenance Manual to perform inspections.

NOTICE

JLG INDUSTRIES, INC. RECOGNIZES A FACTORY-TRAINED SERVICE TECHNICIAN AS A PERSON WHO HAS SUCCESSFULLY COMPLETED THE JLG SERVICE TRAINING SCHOOL FOR THE SPECIFIC JLG PRODUCT MODEL.

SECTION 2 - USER RESPONSIBILITIES, MACHINE PREPARATION AND INSPECTION

2.3 PRE-START INSPECTION

The Pre-Start Inspection should include each of the following:

1. **Cleanliness** – Check all surfaces for leakage (oil or battery fluid) or foreign objects. Report this to the proper maintenance personnel.
2. **Structure** - Inspect the machine structure for dents, damage, weld or parent metal cracks or other discrepancies. Report this to the proper maintenance personnel.

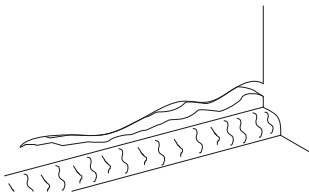

Parent Metal Crack

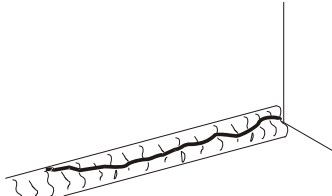

Weld Crack

3. **Decals and Placards** – Check all for cleanliness and legibility. Ensure none of the decals and placards are missing. Ensure all illegible decals and placards are cleaned or replaced. (See Section 5.9, DECAL INSTALLATION)
4. **Operation and Safety Manuals** - Ensure that a copy of the Operation and Safety Manual, AEM Safety Manual (ANSI markets only), and ANSI Manual of Responsibilities (ANSI markets only) is enclosed in the weather resistant storage container.
5. **“Walk-Around” Inspection** – Refer to Figure 2-2. on page 2-9.
6. **Battery** – Charge as required.
7. **Hydraulic Oil Level** - Check the hydraulic oil level in the pump reservoir, add as required. (See Section 5.5)
8. **Accessories/Attachments** - Reference the Operation and Safety Manual of each attachment or accessory installed upon the machine for specific inspection, operation, and maintenance instructions.
9. **Function Check** – Once the “Walk-Around” Inspection is complete, perform a functional check of all systems in an area free of overhead and ground level obstructions. Refer to Section 3 for more specific instructions on the operation of each function.

SECTION 2 - USER RESPONSIBILITIES, MACHINE PREPARATION AND INSPECTION

10. **Platform Gate** - Keep gate and surrounding area clean and unobstructed. Check that gate closes properly and is not bent or damaged. During operation keep gate closed.

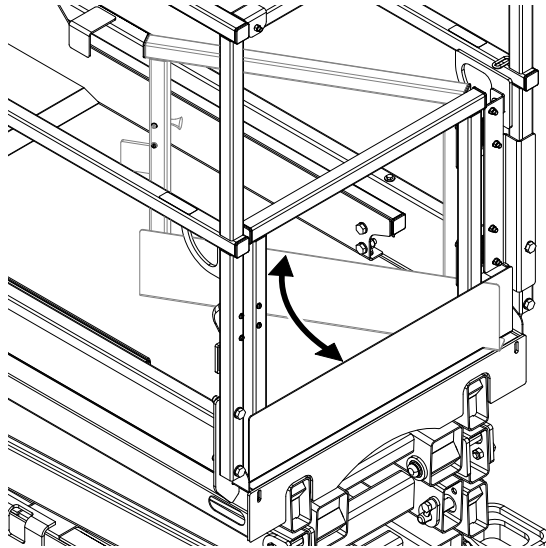

R6

Self-Closing Swing Gate

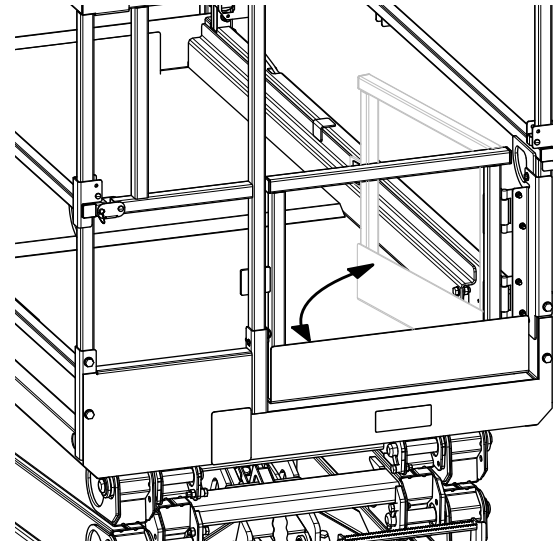

R10

Self-Closing Swing Gate

SECTION 2 - USER RESPONSIBILITIES, MACHINE PREPARATION AND INSPECTION

11. **Lanyard Anchorage Points** - JLG Industries, Inc. recommends personnel in the platform wear a full body harness with a lanyard attached to an authorized lanyard anchorage point (1).

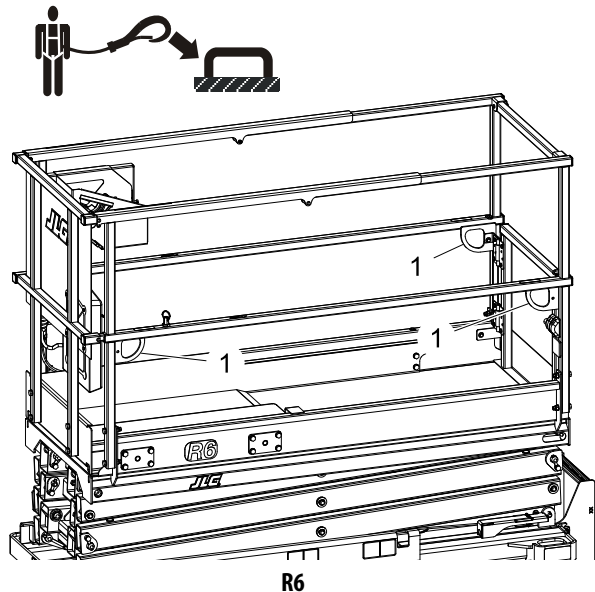

R6
Lanyard Attach Points

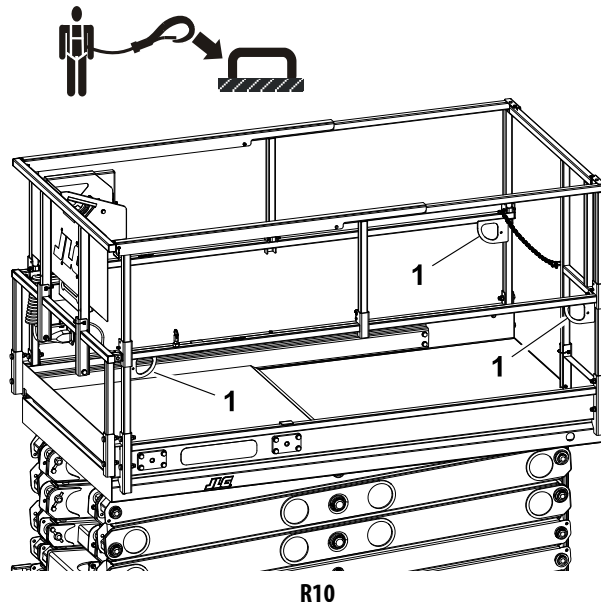

R10
Lanyard Attach Points

2.4 DAILY WALK-AROUND INSPECTION

Begin the “Walk-Around Inspection” at item 1, see Figure 2-1. and Figure 2-2. Continue checking each item in sequence for the conditions listed in the following checklist.

⚠ WARNING

TO AVOID POSSIBLE INJURY, BE SURE MACHINE POWER IS “OFF”. DO NOT OPERATE UNTIL ALL MALFUNCTIONS HAVE BEEN CORRECTED.

NOTICE

DO NOT OVERLOOK VISUAL INSPECTION OF CHASSIS UNDERSIDE. CHECKING THIS AREA MAY RESULT IN DISCOVERY OF CONDITIONS WHICH COULD CAUSE EXTENSIVE MACHINE DAMAGE.

INSPECTION NOTE: On all components, make sure there are no loose or missing parts, that they are securely fastened, and that no visible damage, leaks or excessive wear exists in addition to any other criteria mentioned.

1. Frame/Chassis - *See Inspection Note.* Ensure that pot-hole protection (PHP) components on frame are in place, undamaged, not bent or worn.
2. Ground Controls - Placard secure and legible, control switches return to neutral position, emergency stop switch functions properly. Control markings legible.

3. Hydraulic Pump/Motor, Control Valve Installation - No unsupported wires or hoses; no damaged or broken wires - *See Inspection Note.*
4. Front Wheels - Steer linkage, and Steer Cylinder - *See Inspection Note.*
5. Battery Compartment - *See Inspection Note.*
6. Rear Wheels, Tires and Drive Motors - Properly secured, no missing lug nuts. Refer to Section 5.7, TIRES AND WHEELS. Inspect wheels for damage and corrosion - *See Inspection Note.*
7. Manual Descent Control - *See Inspection Note.*
8. Beacon (*if equipped*) - *See Inspection Note.*
9. Scissor Arms, Pivot Pins and Sliding Wear Pads, Lift Cylinder - *See Inspection Note.*
10. Platform/Handrail/Gate Installation - Deck extension slides in and out and locks in place properly. Gate closes properly. All fold-down rail pins in place and secure - *See Inspection Note.*
11. Platform Control Console - Ensure that the control console is firmly secured in the proper location. Placards secure and legible, control lever and switches return to neutral, and emergency stop switch function properly, required manuals in storage box.

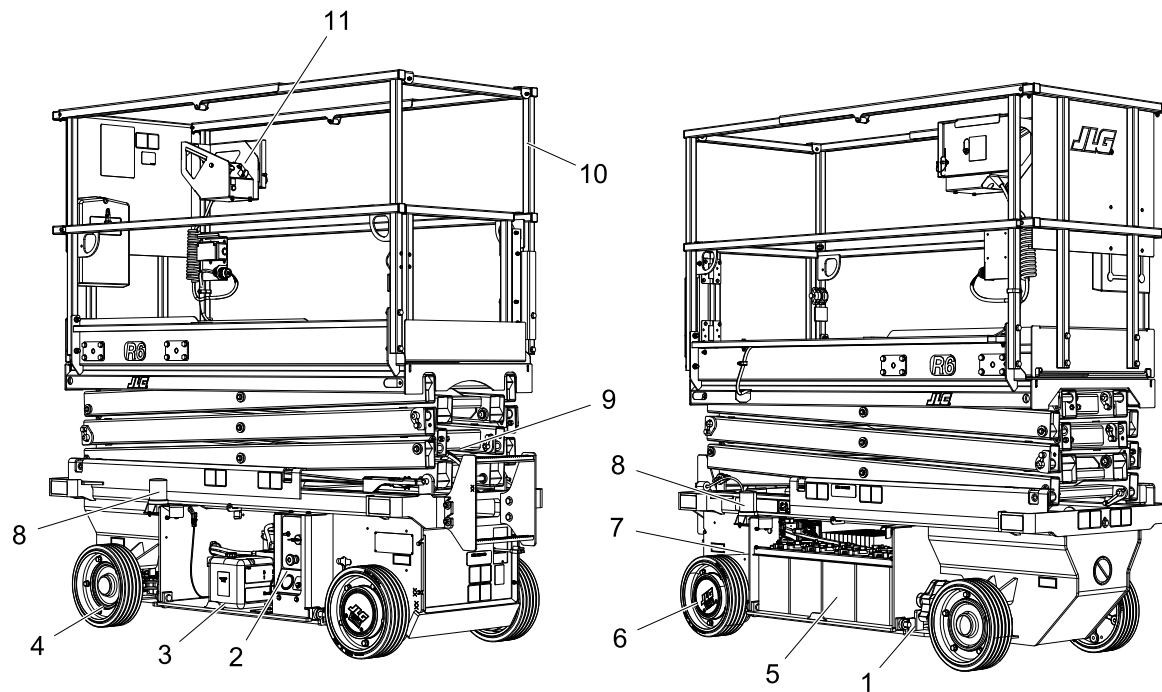

Figure 2-1. R6 - Daily Walk-Around Inspection (Side Covers Removed)

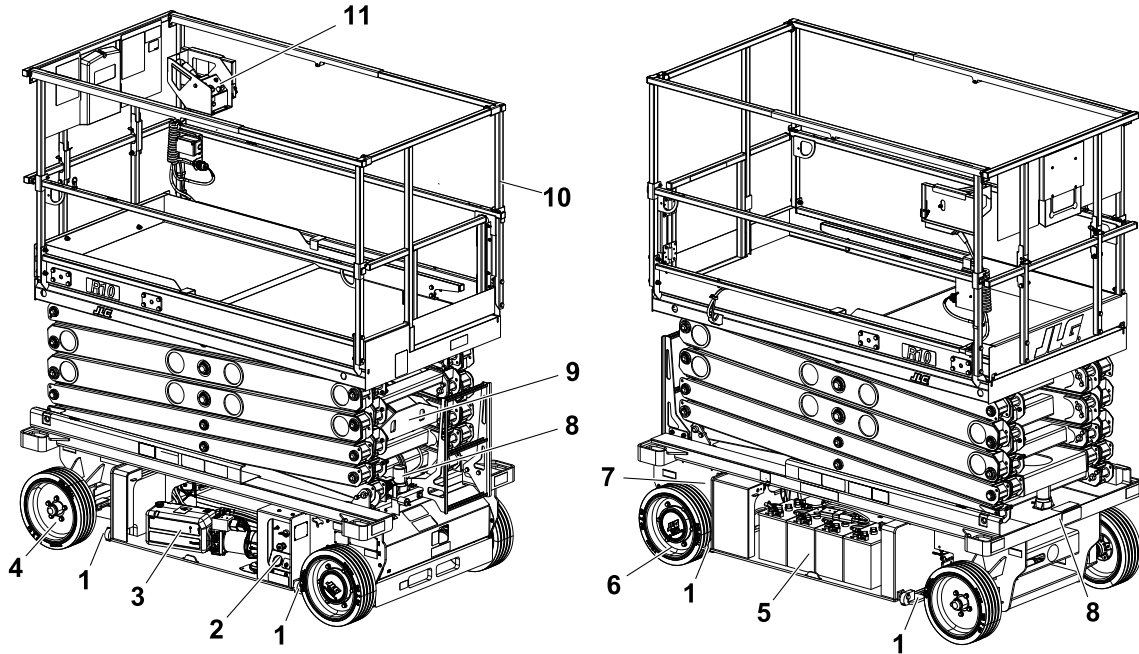
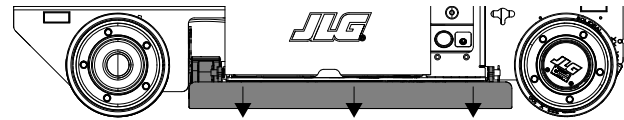

Figure 2-2. R10 - Daily Walk-Around Inspection (Side Covers Removed)

2.5 FUNCTION CHECK

Perform the Function Check as follows:

1. From the **Ground Control Panel** with no load in the platform:
 - a. Ensure that the key selector switch and the platform lift switch operates properly.
 - b. Ensure that all machine functions are disabled when the Emergency Stop Button is depressed.
 - c. With platform raised a few feet (1m), ensure that the manual descent control (*located at the right rear of the machine*), lowers the platform properly.
 - d. Operate all functions and check all limiting and cutout switches (*See Figure 2-4. on page 2-13*). Check that pot-hole-protection system bars are fully lowered when the platform is raised.



Platform Elevated - Pot-Hole Bars Fully Lowered

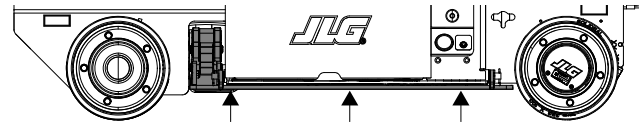

Platform Fully Lowered - Pot-Hole Bars Raised

Pot-Hole-Protection System - Operation

2. From the **Platform Control Console**:
 - a. Ensure that the control console is firmly secured in the proper location.
 - b. Ensure that all guards protecting switches are in place.
 - c. Operate all switch functions, drive/lift mode select switch, and horn button.
 - d. Operate all platform joystick functions to ensure proper operation of drive, lift, steer, and enable trigger switch operation.

SECTION 2 - USER RESPONSIBILITIES, MACHINE PREPARATION AND INSPECTION

- e. Ensure that all machine functions are disabled when the platform Emergency Stop Button is depressed.
- f. With the platform elevated on a smooth, firm, level surface with no overhead obstructions, drive the machine to check if the high drive cutout speed-limit is engaged at the height indicated in Table 2-2. Ensure drive speed is reduced from a top speed to a slower speed. Limit switch locations shown in (Figure 2-3. and Figure 2-4.).

Table 2-2. High Drive Cutout Height

MODEL	HIGH DRIVE SPEED CUTOUT HEIGHT	DRIVE SPEED REDUCTION
R6 (Australia)	69 in. (1.75 m)	2.5 mph (4.0 kph) to 0.5 mph (0.8 kph)
R6 (ANSI)	69 in. (1.75 m)	2.5 mph (4.0 kph) to 0.6 mph (1.0 kph)
R10 (ANSI)	88.5 in. (2.25 m)	2.5 mph (4.0 kph) to 0.6 mph (1.0 kph)

- 3. With the platform in the transport (stowed) position.
 - a. Drive the machine on a grade, not to exceed the rated gradeability, and stop to ensure the drive motor brakes hold.

- b. Check the tilt indicator light to ensure proper operation. The light should be illuminated if tilted beyond allowed settings in Table 2-3.

NOTE: When the tilt indicator warning is activated the following functions are affected;

Platform Lowered: Only Drive Allowed.

Platform Raised: Drive and lift up functions are disabled, platform must be fully lowered (stowed) to drive out of tilt condition.

Table 2-3. Tilt Activation Setting

MODEL	TILT SETTING (front to back)	TILT SETTING (side to side)	Maximum Deck Elevation	
R6 (AUS)	3°	1.5°	5.64 m (Full)	18.5 ft.
		2°	5.2 m	17 ft.
		3°	4.6 m	15 ft.
R6 (ANSI)	3°	1.5°	5.79 m (Full)	19 ft.
		2°	5.2 m	17 ft.
		3°	4.6 m	15 ft.
R10 (ANSI)	3°	2°	9.75 m (Full)	32 ft.
		2.5°	6.7 m	22 ft.
		3°	6 m	20 ft.

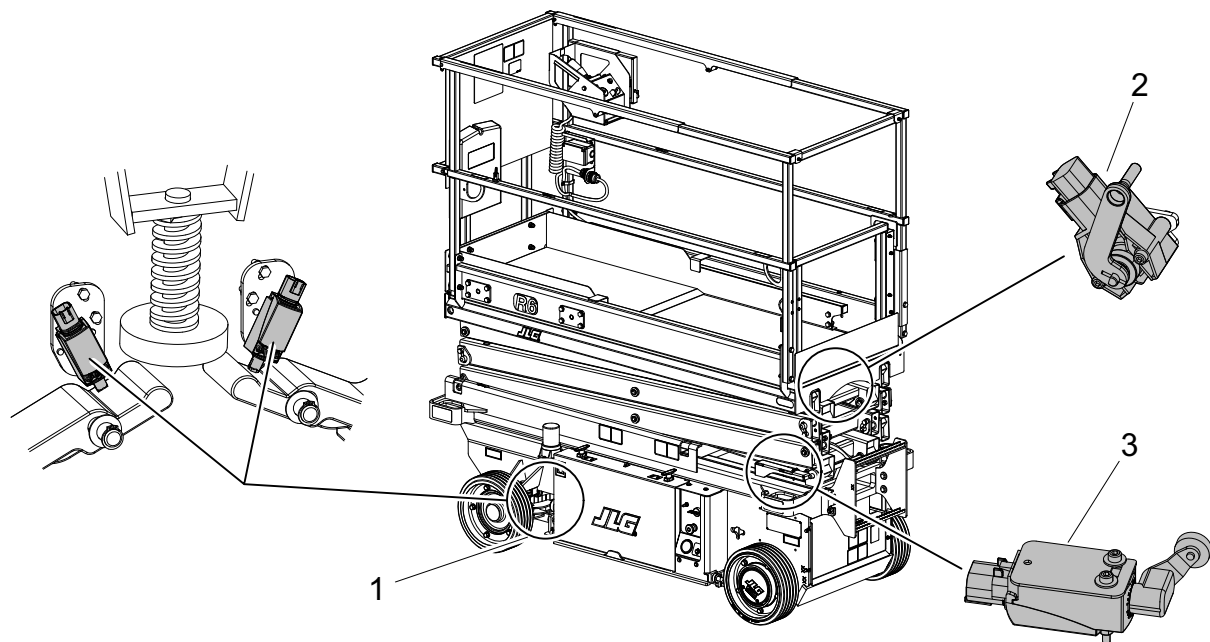

Figure 2-3. R6- Machine Limit Switch Location

1. PHP Switch (Pot-Hole-Protection)

2. Scissor Arm- Rotary Angle Switch

3. Platform - Elevation Switch

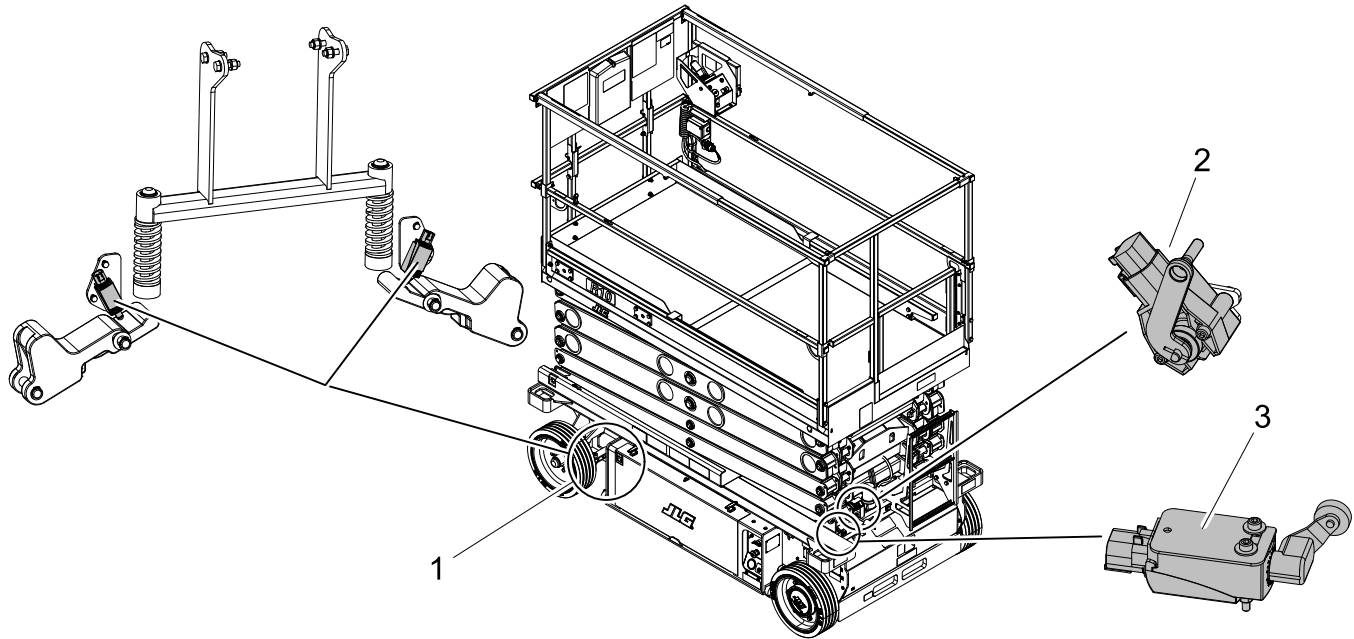

Figure 2-4. R10 - Machine Limit Switch Location

1. PHP Switch (Pot-Hole-Protection)

2. Scissor Arm - Rotary Angle Switch

3. Platform - Elevation Switch

SECTION 3. MACHINE CONTROLS, INDICATORS AND OPERATION

3.1 GENERAL

NOTICE

THE MANUFACTURER HAS NO DIRECT CONTROL OVER MACHINE APPLICATION AND OPERATION, THE USER AND OPERATOR ARE RESPONSIBLE FOR CONFORMING WITH GOOD SAFETY PRACTICES.

This section provides the necessary information needed to understand controls and their functions.

⚠ WARNING

DO NOT RAISE PLATFORM EXCEPT ON A SMOOTH, FIRM AND LEVEL SURFACE FREE OF OBSTRUCTIONS AND HOLES.

TO AVOID SERIOUS INJURY, DO NOT OPERATE MACHINE IF ANY CONTROL LEVERS OR TOGGLE SWITCHES CONTROLLING PLATFORM MOVEMENT DO NOT RETURN TO THE OFF OR NEUTRAL POSITION WHEN RELEASED.

IF THE PLATFORM DOES NOT STOP WHEN A CONTROL SWITCH OR LEVER IS RELEASED, USE THE EMERGENCY STOP SWITCH TO STOP THE MACHINE.

3.2 DESCRIPTION

This machine is a self-propelled aerial work platform on top of an elevating scissor arm mechanism. The Lift's intended purpose is to position personnel with their tools and supplies at positions above ground level. The machine can be used to reach work areas located above machinery or equipment positioned at ground level.

This JLG Lift has a primary operator control station in the platform. From this control station, the operator can drive and steer the machine in both forward and reverse directions, raise and lower the platform.

The machine can be driven on a smooth, firm, and level surface from an elevated platform position - Reference "Steering And Traveling" on page 3-17. of this manual for specific requirements.

The machine also has a ground control station which can override the platform control station. Ground controls operate lift up and down. Ground controls are to be used only in an emergency to lower the platform to the ground should the operator in the platform be unable to do so.

3.3 OPERATING CHARACTERISTICS AND LIMITATIONS

General

A thorough knowledge of the operating characteristics and limitations of the machine is always the first requirement for any user, regardless of user's experience with similar types of equipment.

Placards

Important points to remember during operation are provided at the control stations by DANGER, WARNING, CAUTION, NOTICE, and INSTRUCTION placards. This information is placed at various locations for the express purpose of alerting personnel of potential hazards constituted by the operating characteristics and limitations of the machine. See foreword for definitions of placard safety signal words.

3.4 PLATFORM LOADING

The platform maximum rated load capacity is shown on a placard located on the platform billboard and ground control station and is based upon the machine positioned on a smooth, firm, and level surface. Refer to Section 5, Table 5-2 on page 5-3, for the maximum platform capacity.

The platform is entered through an entry gate at the rear of the platform. Keep entry gate closed during machine operation.

NOTE: *It is important to remember that the load should be evenly distributed on the platform. The load should be placed near the center of the platform when possible.*

3.5 MACHINE CONTROL LOCATIONS

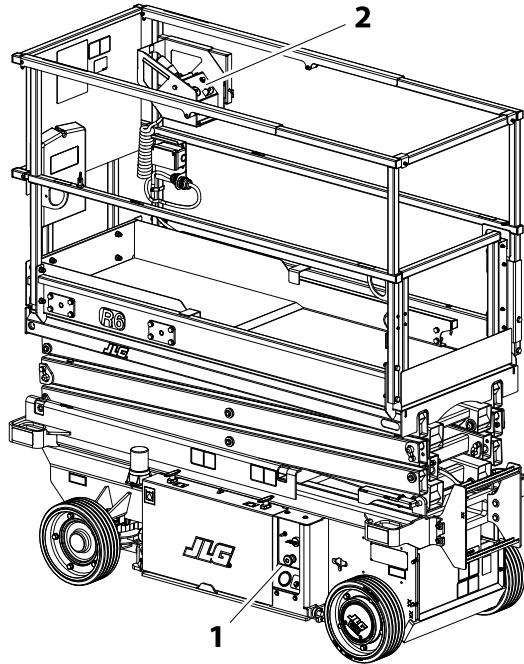

- 1. Ground Control Station
- 2. Platform Control Station
- 3. Platform Manual Descent Control
- 4. AC Plug - To Platform AC Receptacle Outlet Box
- 5. AC Plug - Battery Charger Input Plug

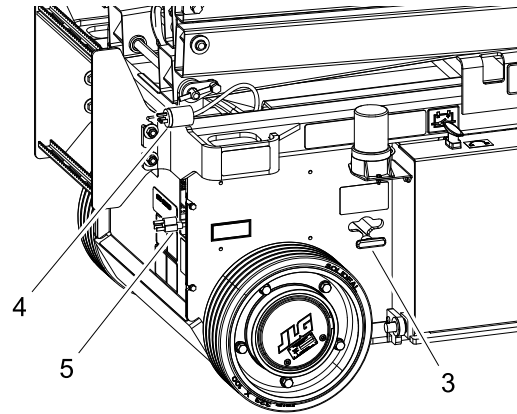
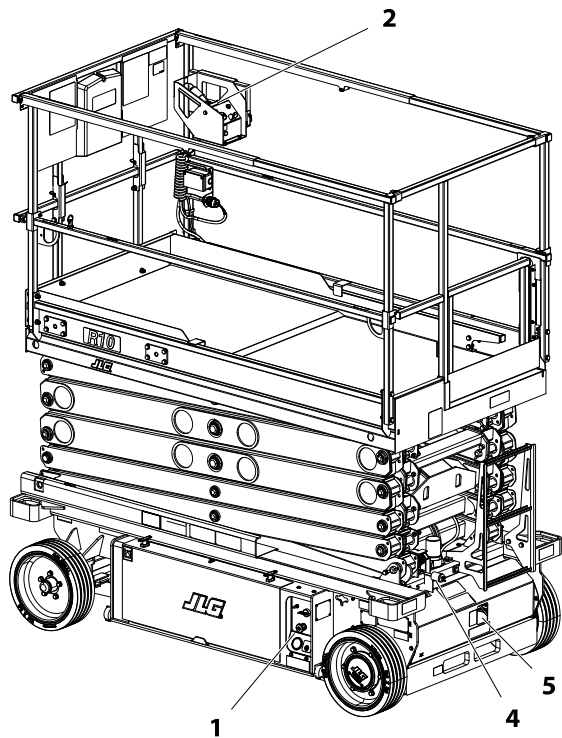

Figure 3-1. R6 - Location of Machine Controls.

SECTION 3 - MACHINE CONTROLS, INDICATORS AND OPERATION



1. Ground Control Station
2. Platform Control Station
3. Platform Manual Descent Control
4. AC Plug - To Platform AC Receptacle Outlet Box
5. AC Plug - Battery Charger Input Plug

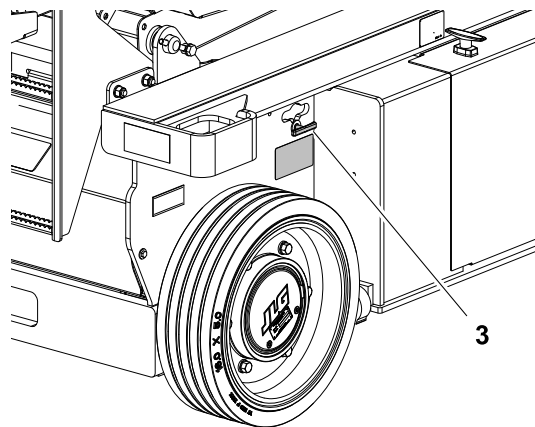

Figure 3-2. R10 - Location of Machine Controls.

3.6 BATTERY CHARGING

NOTE: Be sure that machine is parked in a well ventilated area before charging begins.

CAUTION

ONLY PLUG THE CHARGER INTO A PROPERLY INSTALLED AND GROUNDED OUTLET. DO NOT USE GROUND ADAPTORS OR MODIFY PLUG. DO NOT TOUCH NON-INSULATED PORTION OF OUTPUT CONNECTOR OR NON-INSULATED BATTERY TERMINAL.

DO NOT OPERATE CHARGER IF THE AC SUPPLY CORD IS DAMAGED OR IF THE CHARGER HAS RECEIVED A SHARP BLOW, BEEN DROPPED, OR OTHERWISE DAMAGED IN ANY WAY.

ALWAYS DISCONNECT THE CHARGER AC SUPPLY BEFORE MAKING OR BREAKING THE (POS/NEG) CONNECTIONS TO THE BATTERY.

DO NOT OPEN OR DISASSEMBLE CHARGER.

1. The battery charger AC input plug is located in an opening on the panel at the lower rear of the machine.
2. Connect the charger AC input plug to a grounded outlet using a 3 wire heavy duty extension cord. (See Table 5-6, "Electrical System Specifications," on page 5-5, for battery charger AC input specifications.)
3. When powered up the charger will go through a short LED indicator self-test. The battery charger LED indicators on the charger (Figure 3-3.), will flash in sequence for two seconds. These LED indicators can be viewed

through the opening on the rear panel where the charger AC cord is accessed.

4. The batteries are fully charged when the green light on the battery charger status panel is illuminated.

NOTE: If the charger is left plugged in, the charger will automatically restart a complete charge cycle if the batteries voltage drops below a minimum voltage or 30 days has elapsed.

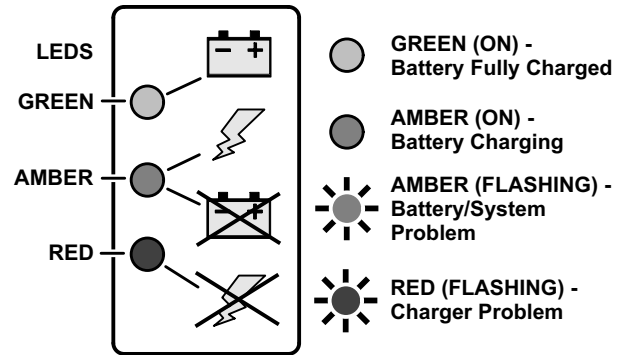

Figure 3-3. Charger Decal LED Indicators

SECTION 3 - MACHINE CONTROLS, INDICATORS AND OPERATION

Battery Charger Fault (LED Flash)

If a fault has occurred during battery charging, the (AMBER or RED) LED on the charger LED indicator (*See Figure 3-3.*) will flash corresponding to the fault which occurred. Refer to Table 3-1 following for the charger LED flash codes and their meaning.

If required, further general and troubleshooting information about the battery charger can be found in the charger manufacturer's Owner's Guide.

Table 3-1. Battery Charger Fault (LED Flash)

FLASHING LED	FAULT	REMEDY
AMBER	Battery High Voltage	Upon battery voltage >2.5V per cell @ startup, charger shall flash amber LED and not allow charging - Battery or System problem.
AMBER	Battery Low Voltage	Upon battery voltage <0.17V per cell @ startup, charger shall flash amber LED and not allow charging - Battery or System problem.
AMBER	Failed Trickle to min V	Should battery fail to reach 1.75V per cell charge shall flash an amber LED until charger is power cycled - Battery or System problem.
RED	Charger Internal Fault	Signals a hardware fault of the charger and shall indicate flashing red LED.

3.7 GROUND CONTROL STATION

⚠ WARNING

DO NOT OPERATE FROM GROUND CONTROL STATION WITH PERSONNEL IN THE PLATFORM EXCEPT IN AN EMERGENCY.

PERFORM AS MANY PRE-OPERATIONAL CHECKS AND INSPECTIONS FROM THE GROUND CONTROL STATION AS POSSIBLE.

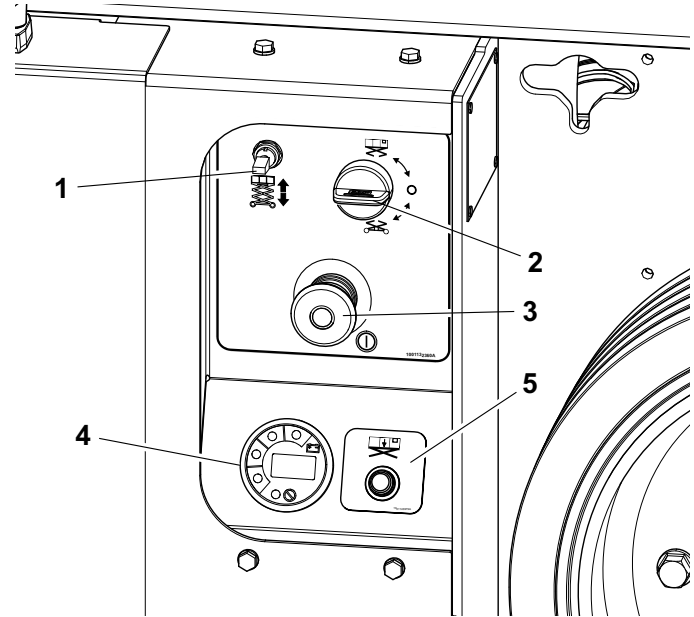

Figure 3-4. Ground Control Station

- | | |
|---------------------------------|-------------------------------------|
| 1. Platform Lift/Lower Switch | 4. MDI - Indicator |
| 2. Key Selector Switch | 5. Overload Indicator (If Equipped) |
| 3. Ground Emergency Stop Button | |

SECTION 3 - MACHINE CONTROLS, INDICATORS AND OPERATION

Ground Emergency Stop Switch - (Item 3 - Figure 3-4.)

Power is turned on by pulling the switch out, and is turned off by depressing switch. A two-position, red, mushroom-shaped emergency stop switch, when positioned to ON with the key selector switch positioned to ground, furnishes operating power to the ground control station key switch. In addition, the switch can be used to turn off power to the function controls in the event of an emergency.

Key Selector Switch - (Item 2 - Figure 3-4.)

The key selector switch on the Ground Control Station functions to direct electrical power to the desired control station. With the switch turned to the **ground position (1)**, power is supplied to the controls at the ground control station. When the switch is turned to the **platform position (2)**, power is supplied to the controls at the platform control station. The switch should be set to the **OFF position (3)** when parking the machine overnight.

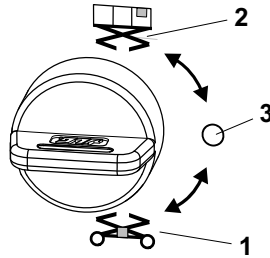

Platform Lift/Lower Switch - (Item 1 - Figure 3-4.)

A three position, momentary contact lift control switch provides raising and lowering of the platform from the Ground Control Station.

When operating platform from the ground controls -

Toggle the lift/lower switch to up position and hold to raise platform, or down position and hold to lower an elevated platform. Release to center position to stop all movement.

MDI-Indicator - (Item 4 - Figure 3-4.)

The MDI indicator or Multifunction Digital Indicator displays a Battery Discharge Indicator (BDI), an LCD display which shows the current hour-meter reading or Diagnostic Trouble Code(s) (DTC) when a functional problem occurs with the machine, and a system distress LED.

When a problem occurs (DTC Code displayed):

A **wrench icon (item 1)** will display on the **Diagnostic Trouble Code LCD display (item 2)**. (See Figure 3-5.)

- A three to five digit DTC code will display on the **Diagnostic Trouble Code LCD display (item 2)**, below the wrench icon.
- The system distress **LED indicator (RED) (item 3)** lights up solid on the MDI when a DTC Code is displayed on the LCD display

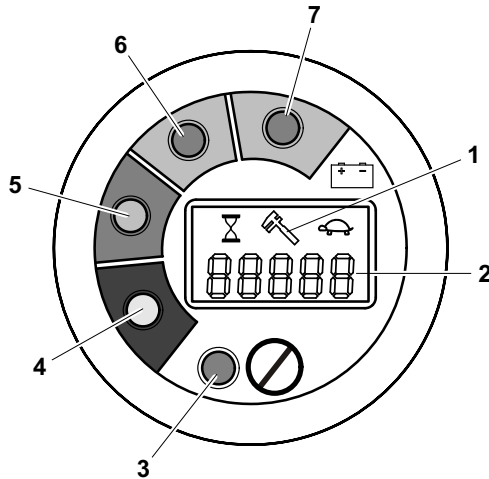

Figure 3-5. MDI Indicator

- | | |
|---|---------------------------------------|
| 1. HourMeter, Wrench, Creep Icon Indicators | 5. 50% Charge Indicator (YELLOW AREA) |
| 2. Hour-meter/DTC Code Display | 6. 75% Charge Indicator (GREEN AREA) |
| 3. System Fault LED Indicator (RED LED) | 7. 100% Charge Indicator (GREEN AREA) |
| 4. 0-25% Charge Indicator (RED AREA) | |

NOTE: When more than one DTC exists, each DTC will be displayed on the LCD for 3 seconds before changing to the next DTC. Once the last active DTC is displayed, the display will recycle indefinitely until the DTC's are corrected. For DTC's and descriptions, refer to Section 5.10.

Also located on the MDI are **Battery Discharge Indicators (BDI) (items 4 thru 7)**. (4) GREEN LEDs indicate the level of charge (voltage) remaining in the batteries.

NOTE: When the battery voltage is low and will need a charge soon, the **LED (item 4)** in the 0-25% range "red area" will flash.

Under normal operating conditions the BDI's and hour-meter will be displayed. When a DTC exists (other than 00x DTC's) the BDI LEDs and hour-meter will not be displayed. Also when platform is elevated and the machine is being driven the creep mode (turtle) is displayed.

Overload Indicator (If Equipped) - (Item 5 - Figure 3-4.)

Overload Indicator - Indicates the platform has been overloaded. An audible alarm will also signal when the platform is overloaded.

NOTE: If the Overload Indicator is illuminated, all functions will be prevented from the platform and ground controls. Reduce the weight in the platform to not exceed the rated workload indicated on the capacity decal.

Platform Manual Descent Control

The platform manual descent control is used in the event of total power failure to lower the platform using gravity. The manual descent control T-handle is located on the right rear of the machine, just in front of the drive wheel.

The lowering procedure is as follows:

1. Locate the **manual descent control T-handle**.
(See Figure 3-7.)

⚠ WARNING

KEEP HANDS AND ARMS OUT OF THE PATH OF THE SCISSOR ARMS AND PLATFORM WHILE LOWERING.

2. Grasp the T-handle and slowly pull out to lower the scissor arms/platform, when the platform is lowered to desired level, allow the T-handle to return to its closed position.

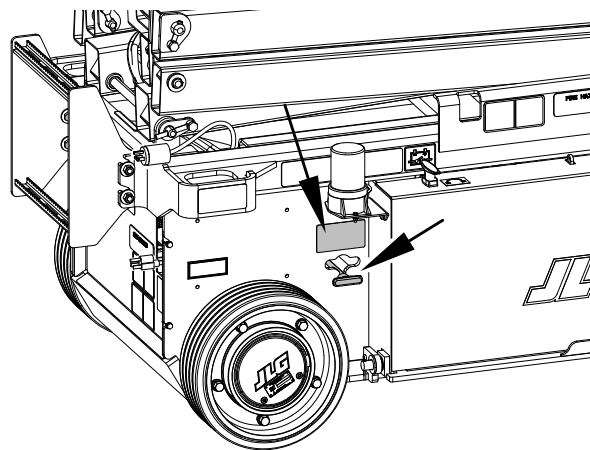
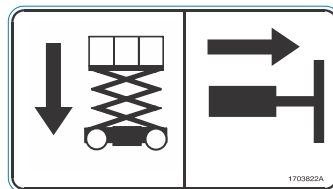

**Figure 3-6. R6 - Location of Manual Descent Control
(Right Rear of Machine)**

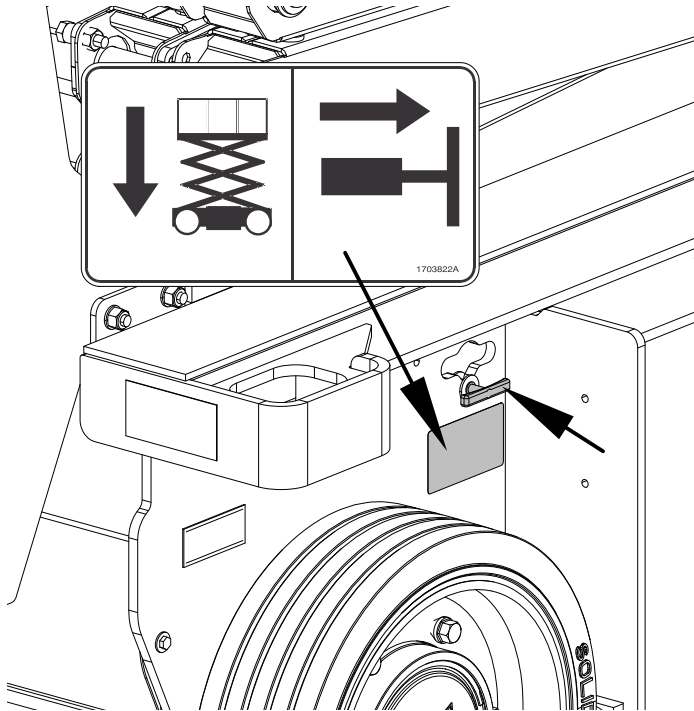

**Figure 3-7. R10 - Location of Manual Descent Control
(Right Rear of Machine)**

3.8 SCISSOR ARM - SAFETY PROP

(See Figure 3-8. and Figure 3-9.)

WARNING

NEVER WORK UNDER AN ELEVATED PLATFORM UNTIL IT HAS BEEN RESTRAINED FROM MOVEMENT WITH THE SAFETY PROP, BLOCKING OR OVERHEAD SLING.

The safety prop is located at the rear of the machine on the rod end of the lift cylinder located between the scissor arms.

To engage the safety prop:

1. From the Ground Control Station, raise the platform far enough to allow the safety prop to be engaged on the lift cylinder rod.
2. Pull out/up on the stop handle to release the safety prop locking pin.
3. Rotate the prop assembly until it rests on the lift cylinder rod.
4. Lower the platform until the safety prop rests against the head of the lift cylinder, stopping all downward movement of the platform/scissor arm assembly.

To release the safety prop:

1. Raise the platform enough to release the safety prop off the head of the cylinder.
2. Pull the prop handle downward to restore the prop back to its released position.
3. Ensure the locking pin to hold the safety prop in the released position is engaged.

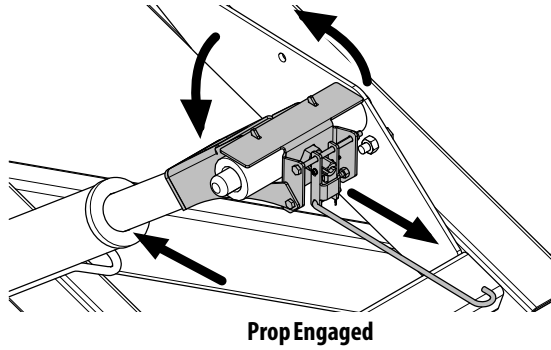

Prop Engaged

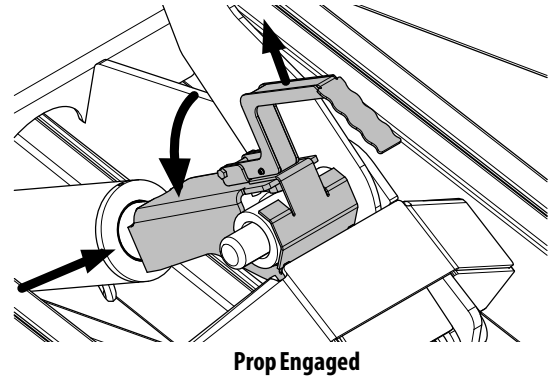

Prop Engaged

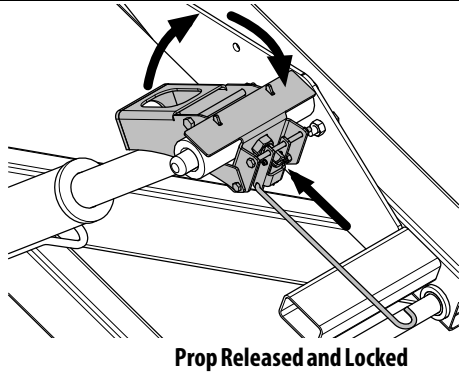

Prop Released and Locked

Figure 3-8. R6 - Scissor Arm - Safety Prop

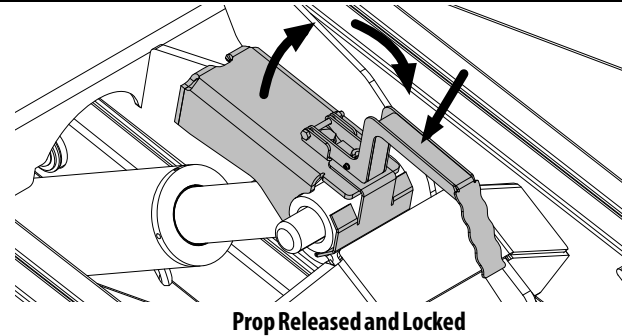

Prop Released and Locked

Figure 3-9. R10 - Scissor Arm - Safety Prop

3.9 PLATFORM CONTROL STATION

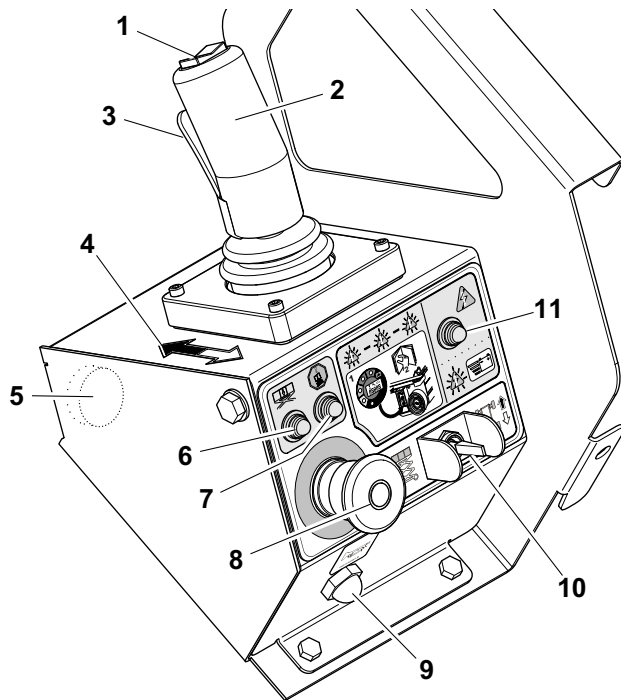

1. Steer Control Switch
2. Drive and Lift Joystick Control
3. Trigger Switch
4. Forward/Reverse/Lift/Lower Direction Decal
5. Alarm
6. Overload Indicator (If Equipped)
7. Machine Tilt Indicator
8. Emergency Stop Switch
9. Horn Button
10. Drive and Lift Select Switch
11. Low Battery Charge and System Fault Indicator

Figure 3-10. Platform Control Station.

Platform Emergency Stop Switch - (Item 8 - Figure 3-10.)

NOTE: Both the ground and platform emergency stop buttons must be set to ON in order to operate the machine.

When power is directed to the platform from the ground control station, the platform emergency stop switch is turned on by pulling the switch out (on), and is turned off by pushing the switch in (off). The two-position, red, mushroom-shaped emergency stop switch functions to provide power to the platform control station and also to turn off power to machine functions in the event of an emergency.

Lift/Drive Select - (Item 10 - Figure 3-10.)

NOTE: When selecting between the Lift and Drive functions the joystick control must be returned to the neutral position for approximately 1/2 second before the function change is operable.

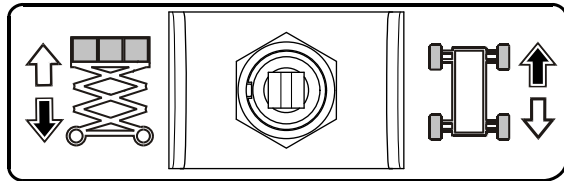

This toggle switch is used to select operation of either the drive or lift function. After selecting a function, the joystick controller must be moved in the proper direction in order to activate that function. Only change the function selected, with the joystick in the neutral position. Otherwise, the function selected will not change until the joystick is returned to the neutral position.

Forward/Reverse/Lift/Lower Direction

Decal - (Item 4 - Figure 3-10.)

This decal indicates the proper direction to mount the platform control box, the black arrow must point to the front of the machine. The black/white arrow also indicates the direction to move the joystick control per the lift/drive selector switch decal for the lift and drive select functions.

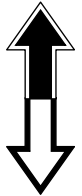

Drive/Lift/Steer Joystick Control

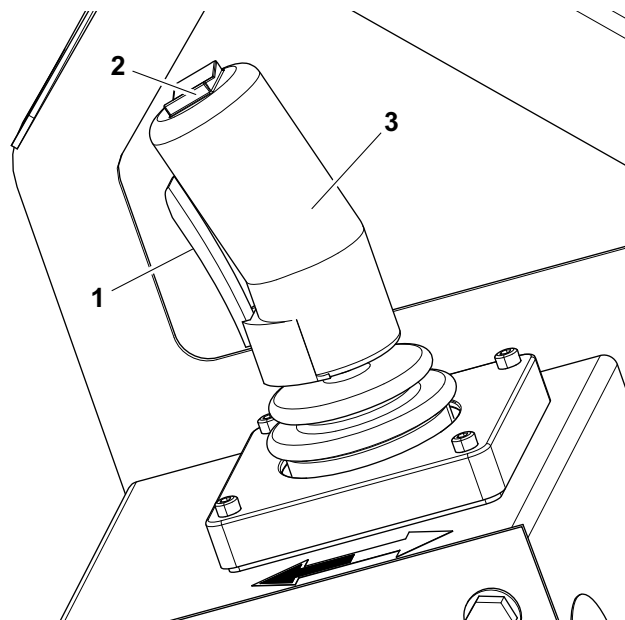

Figure 3-11. Platform Control Components

1. Trigger Switch
2. Steer Switch

3. Joystick Controller

1. **Trigger Switch** - This switch is located on the front of the joystick controller. The trigger switch acts as an enable and must be depressed before operating the drive, steer and lift functions. When released, the function being operated will stop.

NOTE: *Once the trigger switch is pressed, the operator has (5) seconds to begin operating a function, after 5 seconds you must release the trigger switch and press it again to operate a joystick function.*

The speed on all selected functions is proportionally controlled by the distance from the neutral (center) position of the joystick controller.

NOTE: *If the machine is equipped with a foot-switch (Japanese Specification Only), the foot-switch must be depressed in conjunction with the red trigger switch, located on the controller. Power is removed from the platform controls when the footswitch is released.*

2. **Steer Switch** - The steer switch is a thumb operated switch located at the top of the control handle. Depressing the switch to the right will steer the wheels to the right. Depressing the switch to the left will steer the wheels to the left.
3. **Joystick Controller** - The control handle controls three functions: drive, lift, and steer.

Steering And Traveling

WARNING

DO NOT DRIVE WITH PLATFORM RAISED EXCEPT ON A SMOOTH, FIRM AND LEVEL SURFACE FREE OF OBSTRUCTIONS AND HOLES.

TO AVOID LOSS OF TRAVEL CONTROL OR UPSET ON GRADES AND SIDESLOPES, DO NOT DRIVE MACHINE ON GRADES OR SIDESLOPES EXCEEDING THOSE SPECIFIED IN TABLE 5-1 ON PAGE 5-2.

BEFORE DRIVING, LOCATE THE DECALS WITH THE BLACK/WHITE ORIENTATION ARROWS ON THE CHASSIS AND THE PLATFORM CONTROLS. MOVE THE JOYSTICK IN THE DIRECTION OF THE BLACK OR WHITE ARROW THAT MATCHES THE COLOR OF THE ARROW ON THE CHASSIS FOR THE INTENDED DIRECTION OF TRAVEL.

IF THE TILT INDICATOR WARNING LIGHT/ALARM IS ACTIVATED WHILE DRIVING WITH PLATFORM RAISED, LOWER PLATFORM COMPLETELY AND DRIVE TO A FIRM LEVEL SURFACE.

1. Place key selector switch at the ground control station to platform operation.
2. Position emergency stop switches, one at the platform and one at the ground control station to the ON position.

Steering

(Item 2 - Figure 3-11.)

On the platform control station, position the lift/drive select switch to the drive position.

To steer the machine, press the thumb operated steer rocker-switch on the joystick handle to the right for steering right, or to the left for steering left. When released, the switch will return to the center-off position and the wheels will remain in the previously selected position. To return the wheels to the center position, the switch must be activated in the opposite direction until the wheels are centered.

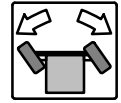

Traveling Forward and Reverse

(Item 1 and 3 - Figure 3-11.)

Position the platform lift/drive select switch to drive/steer position. Squeeze the trigger switch on front of the joystick, and move the joystick forward to drive forward or backward to drive in reverse. The drive system is proportional, for additional drive speed push the joystick further from the neutral position in the direction of travel. Releasing the trigger switch or returning the joystick to center will stop machine movement.

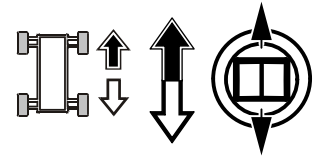

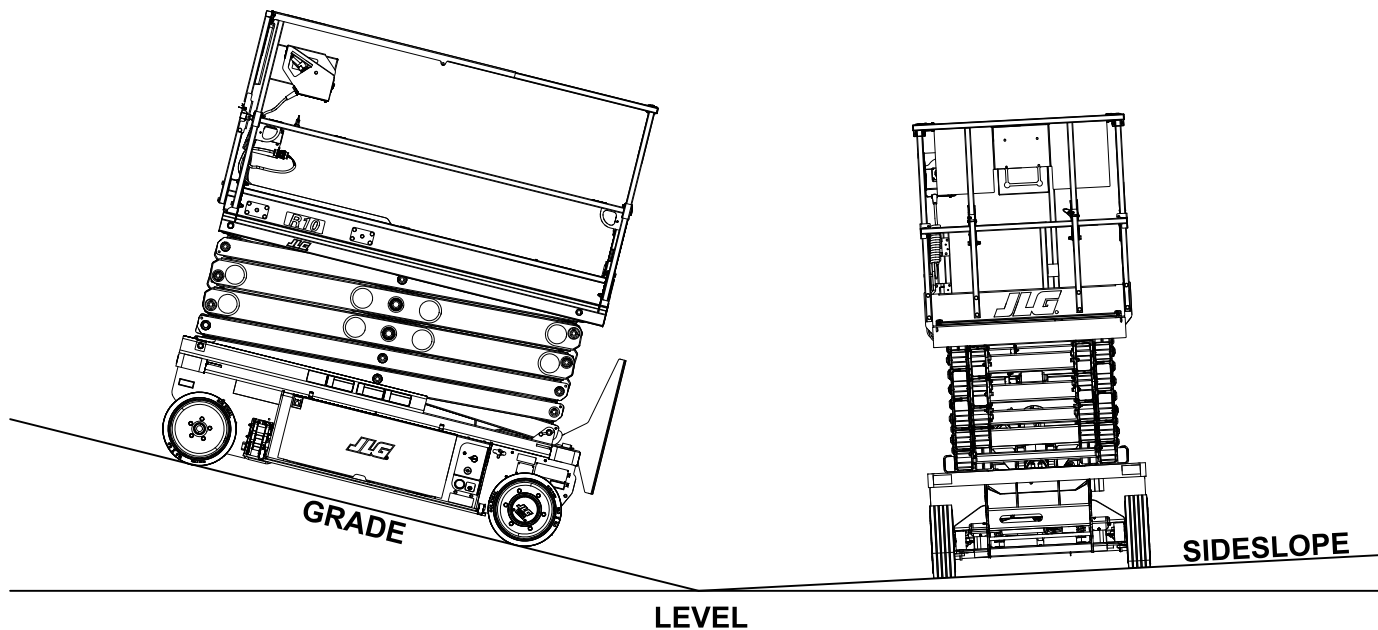
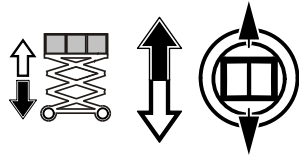

Figure 3-12. Grade and Sideslope Definition

Raising And Lowering Platform

1. If the machine was shut down, place the key selector switch to the desired position (*platform or ground*).
2. Position emergency stop switches, one at the platform and one at the ground control station to the ON position.
3. Position the lift/drive select switch to lift. *(Item 10 - Figure 3-10.)*
4. Squeeze and hold the trigger switch, and move the joystick back (platform up - white arrow direction) or move the joystick forward (platform down - black arrow direction) and hold until desired elevation is reached. Releasing the trigger switch or moving the joystick back to it's center position will stop the function being operated. *(Item 1 and 3 - Figure 3-11.)*



NOTE: To ensure proper operation of the desired platform function, move the joystick in the direction of the black or white arrow that matches the color of the arrow on the chassis for the intended direction of travel.

Overload Indicator (If Equipped) -

(Item 6 - Figure 3-10.)

Indicates the platform has been overloaded. An audible alarm will also signal when the platform is overloaded.

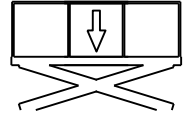

NOTE: If the Overload Indicator is illuminated; **ANSI/ANSI Export/CSA:** All functions will be prevented from the platform and ground controls. Lower platform using the machine manual descent control.

Tilt Indicator Warning Light and Alarm -

(Item 7 - Figure 3-10.)

A red warning light on the control panel illuminates and an audible alarm sounds when the chassis is at or beyond the tilt cutout settings.



⚠ WARNING

IF THE TILT INDICATOR WARNING LIGHT/ALARM IS ACTIVATED WHEN PLATFORM IS RAISED LOWER PLATFORM AND DRIVE TO A SMOOTH FIRM LEVEL SURFACE.

SECTION 3 - MACHINE CONTROLS, INDICATORS AND OPERATION

Horn - (Item 9 - Figure 3-10.)

This push-button switch, when pressed, permits the operator to warn job site personnel when the machine is operating in the area.

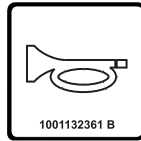

Alarm - (Item 5 - Figure 3-10.)

This alarm mounted on the front of the platform control station will sound for various machine conditions or warnings such as, system ready chirp or if the machine tilt warning is activated.

Low Battery Charge and System Fault

Indicator - (Item 11 - Figure 3-10.)

This indicator light **comes on and stays lit when the battery charge level is very low**, indicating the batteries will need recharging soon.



When indicator light **is flashing a system fault has occurred**, possibly stopping machine operation. Check the MDI indicator on the Ground Control Station to see if a (DTC) Diagnostic Trouble Code(s) is displayed. An explanation of DTC codes is shown in Section 5.10.

If the code cannot be cleared by the operator, the machine will require service by a qualified JLG mechanic.

3.10 PLATFORM EXTENSION

(See Figure 3-13.)

This machine is equipped with an extension deck, giving the operator better access to certain work areas. The deck extension adds length to the front of the platform.

⚠ WARNING

FOR MAXIMUM CAPACITY OF THE DECK EXTENSION SEE SECTION 5, TABLE 5-2 OR REFER TO THE CAPACITY PLACARD ON THE PLATFORM BILLBOARD.

⚠ CAUTION

DO NOT "LOWER" WITHOUT COMPLETELY RETRACTING THE PLATFORM EXTENSION.

To extend the deck:

1. Pull up on the **locking pin (1)** on left side mid-rail near the front of the machine. Rotate pin 90° to hold in up position.
2. Grasp the **top handrails (2)** of the extendible deck and push the extension out until it hits the stops.
3. Re-engage the **locking pin (1)**, move platform extension in or out until the locking pin engages.

To retract the deck:

1. Pull up on the mid-rail **locking pin (1)** and turn the pin 90° to hold in up position.
2. Pull the extension deck all the way back into the main deck using the **top handrail (2)**.
3. Re-engage the mid-rail **locking pin (1)** back to the locked position and engage the hole in the mid-rail.

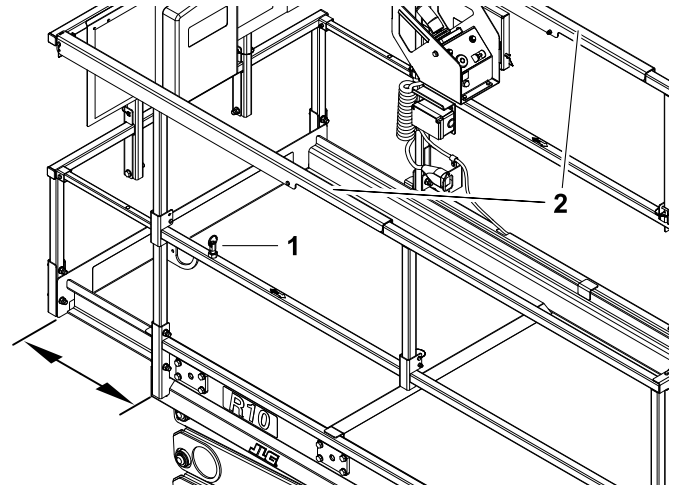

Figure 3-13. R6/R10 - Platform Deck Extension

SECTION 3 - MACHINE CONTROLS, INDICATORS AND OPERATION

3.11 PLATFORM RAILS - FOLD-DOWN PROCEDURE (R10 Only)

(See Figure 3-14.)

WARNING

DO NOT RAISE PLATFORM WITH RAILS FOLDED DOWN. THE RAILS MUST BE IN THE UPRIGHT POSITION AND PROPERLY PINNED WHEN RAISING THE PLATFORM.

NOTE: *The rails must only be folded down when the machine is in the stowed (platform fully lowered) position. The platform control box should be removed from mount before the side rails are folded down.*

The platform rails fold down from the mid rail only, except for the rear gate rail.

NOTE: *If equipped with the optional self-closing gate, the gate must be held open while lowering the rear and side rails.*

The platform rails fold down in the following sequence;
(See Figure 3-14.)

- First - **hold rear gate open, pull pins and fold down rear gate rail (1).**

NOTE: *Front deck extension top rail pins must be removed and deck extension top side rails slid towards rear of machine*

before lowering side rails. Place pins back in the extension side top rails before folding main platform side rails down.

- Second - pull pins, **fold down both side rails (2 & 3).**
- Last - pull pins, fold down **front platform extension rail (4).**
 1. To fold down each of the rails, remove the bail pins for that rail.
 2. Taking a firm hold on the top rail, carefully lower until the top rail is fully folded in the down position.
 3. To raise the rails back to the upright position, unfold the rails in the reverse sequence they were folded. Firmly pull the rails back up into position and replace the bail pins into the rails.
 4. Retract the extension deck and set it's lock pin.

WARNING

AFTER THE RAILS HAVE BEEN FOLDED DOWN, USE EXTREME CAUTION WHEN EXITING AND ENTERING THE PLATFORM. ENTER AND EXIT PLATFORM ONLY AT THE GATE AREA AND LADDER PROVIDED.

WARNING

IF OPERATING (DRIVING) MACHINE WITH PLATFORM CONTROL STATION FROM GROUND, WITH RAILS FOLDED, KEEP AT LEAST 3 FT. (1 M) DISTANCE FROM MACHINE.

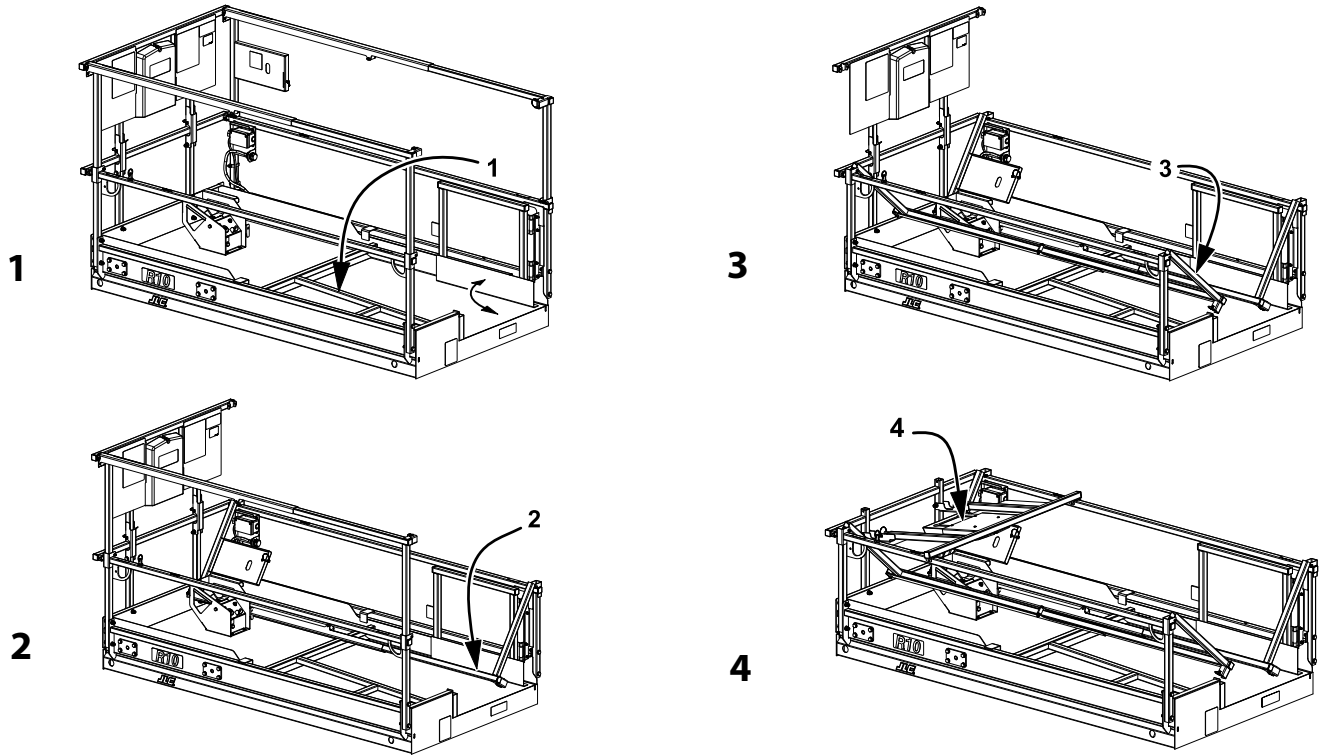

Figure 3-14. R10 - Platform Rails - Fold Down Sequence

3.12 PARKING AND STOWING MACHINE

1. Drive the machine to a well-protected and well-ventilated area.
2. Ensure the platform is fully lowered.

NOTICE

WHEN THE MACHINE IS SHUT DOWN FOR OVERNIGHT PARKING OR BATTERY CHARGING, THE EMERGENCY STOP AND POWER SELECT SWITCHES MUST BE POSITIONED TO OFF TO PREVENT DRAINING THE BATTERIES.

3. At the ground control station, turn the platform - ground selector key switch to OFF and remove the key to disable the machine and prevent unauthorized use.

NOTE: For added protection, the platform control station can be secured to its mounting plate see Figure 3-15.

4. At the ground control station, depress emergency stop switch to the off position.
5. If necessary, cover the platform control box, instruction placards, caution and warning decals so that they will be protected from hostile environment.
6. Chock at least two wheels when parking the machine for an extended period of time.

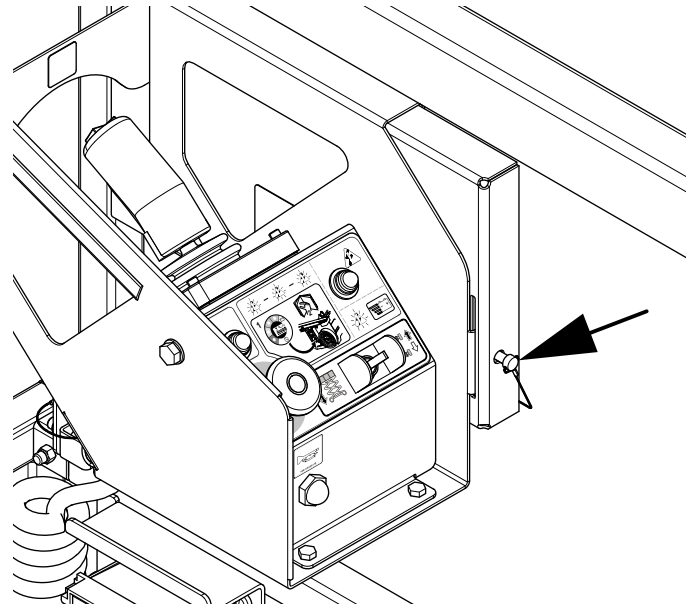

To prevent unauthorized removal, the platform control station can be secured to its mount by replacing the lock pin located on its mounting tab with a keyed or combination lock.

Figure 3-15. Securing Control Station to Platform

Anti-Vandalism Package - Option - (R6 - AUST - Only)

The anti-vandalism package adds hinged metal covers for the platform and ground control stations. These hinged metal covers are also provided with a lock tab for adding a lock to prevent unauthorized operation of the machine when parked and stored overnight, or for extended periods.

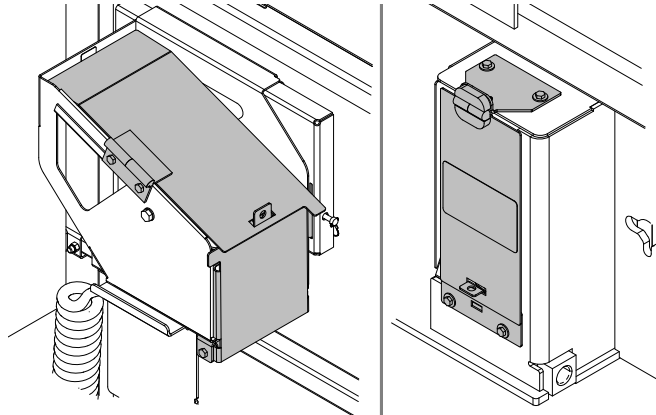

Platform

Ground

Platform - Anti-Vandalism Package - Covers Closed

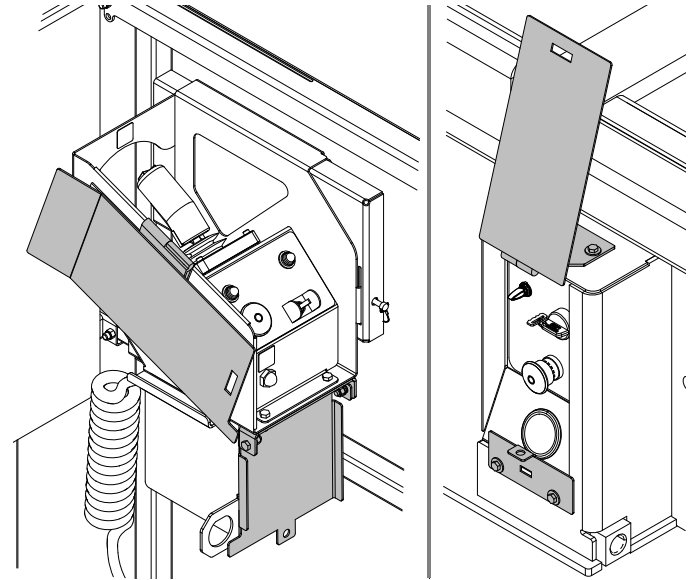

Platform

Ground

Platform - Anti-Vandalism Package - Covers Open

3.13 MACHINE LIFTING AND TIE DOWN

Lifting

The machine may be lifted using a fork lift truck. Lift only from the rear of the machine and only with the platform in the stowed position. Adjust the width of the **forklift truck, lifting tines (1)** to properly fit the machine, see Figure 3-16.

The machine can also be lifted using a spreader bar and four equal length straps or chains capable of supporting the full gross weight of the machine, see Figure 3-17. Lift only using the lifting lugs provided at the four corners of the machine. (See Section 5 for machine gross weight).

⚠ WARNING

LIFTING THE MACHINE FROM THE SIDES USING A FORK TRUCK IS NOT RECOMMENDED BY JLG. IN THE EVENT THAT THE MACHINE NEEDS TO BE LIFTED FROM THE SIDES CAUTION MUST BE USED TO AVOID JAMMING THE POT HOLE PROTECTION BARS UP AGAINST THE FRAME.

EVERY TIME THE MACHINE IS LIFTED FROM THE SIDE, BE SURE AND TEST THE POT HOLE PROTECTION SYSTEM BEFORE THE MACHINE IS PUT BACK INTO OPERATION.

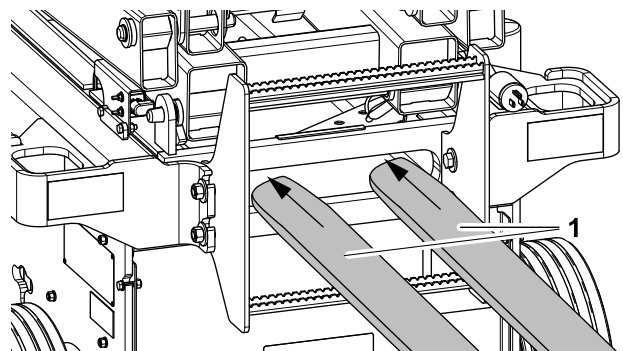

R6

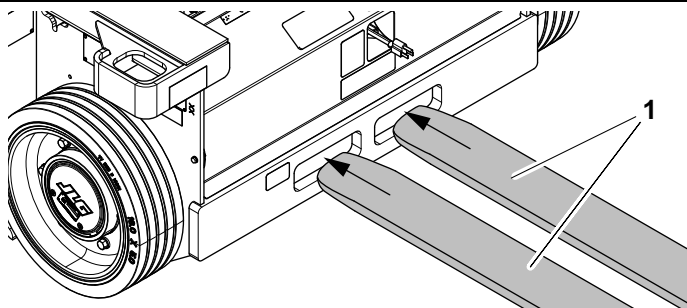

R10

Figure 3-16. Fork Lift Pockets - Location

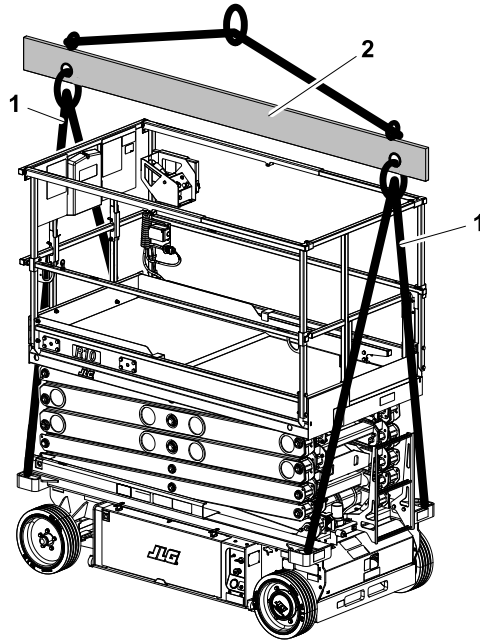

Tie Down

When transporting the machine, the platform must be fully lowered in the stowed position with the machine securely tied down to the truck or trailer deck. There are two tie-down/lift lugs located at the front and rear of the machine. (See Figure 3-18.)

Figure 3-17. R6/R10 - Lifting Machine Using Spreader Bar and Lift Lug Locations

- 1. Four (4) equal length chains or lifting straps.
- 2. Spreader Bar Assembly.

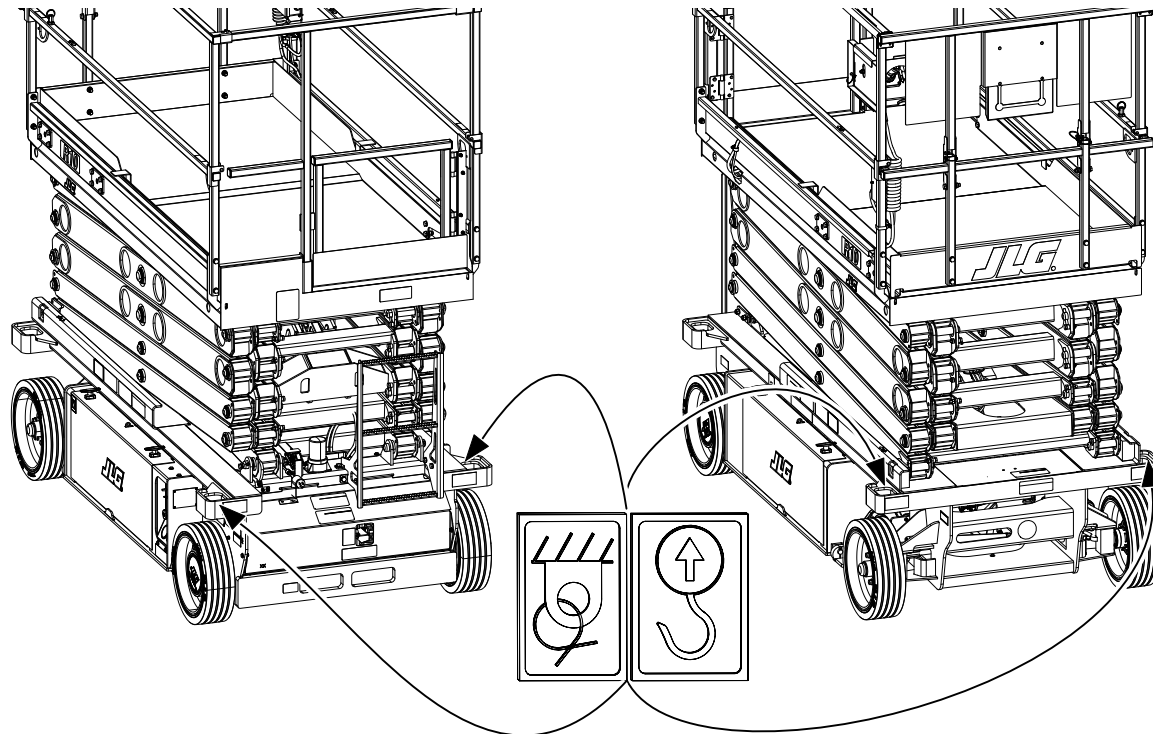

Figure 3-18. R6/R10 - Tie Down and Lift Lug Locations

3.14 TOWING

It is not recommended that this machine be towed, except in the event of an emergency such as a machine malfunction or a total machine power failure.

Electric Brake Release

(See Figure 3-19.)

NOTE: Electrical release of the brakes requires enough battery power to hold the brakes in released mode until destination is reached.

1. Chock wheels or secure machine with tow vehicle.
2. Turn power on in ground mode on the **ground control station (1)**.
3. The **brake release switch (2)** is located inside the hydraulic components side cover, remove cover to access the switch.
4. Depress the brake release switch once to release brakes.
5. When finished towing depress brake release switch again or turn power off at the ground control station to re-engage the brakes.

NOTE: Any action which causes a loss of power from the brakes such as, depressing the ground control emergency stop switch, or switching the key switch to OFF or PLATFORM MODE will re-engage the brakes.

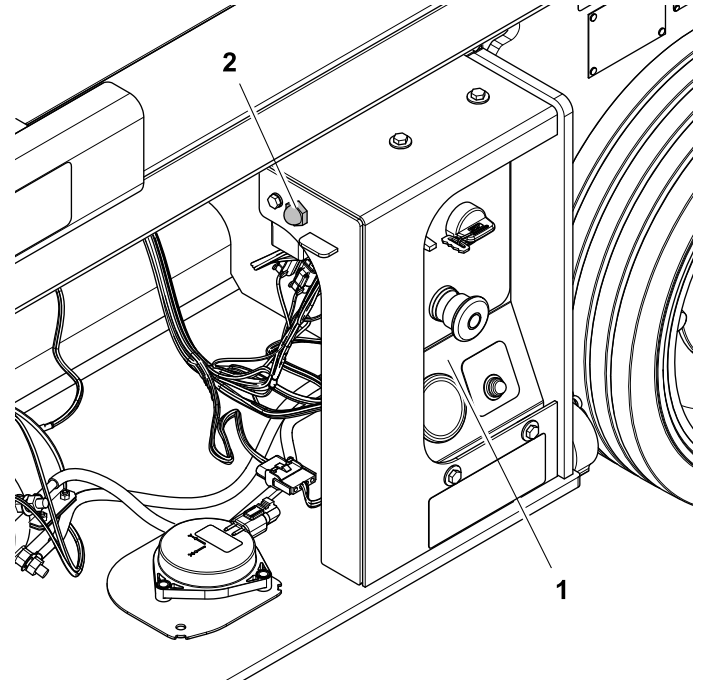

Figure 3-19. R6/R10 - Electric Brake Release - Location

Mechanical Brake Release

(See Figure 3-20.)

⚠ CAUTION

CHOCK WHEELS OR SECURE MACHINE WITH TOW VEHICLE.

1. At the ground control station turn power off by pressing the Emergency Stop switch in.
2. Remove the **two cover bolts (1), and the cover (2)**, from the back of drive motor unit.
3. Insert the **cover bolts (1)** into the **two disengage holes in the brake housing (4)**, see Figure 3-20., Brake - Manual Disengage.
4. Tighten down the **cover bolts (3)** in the disengage holes and the brake on that drive motor will disengage.
5. Repeat this procedure on opposite wheel drive. With both drive motor brakes now disengaged the machine can be moved manually.
6. After towing is complete, chock wheels and remove cover bolts from disengage holes.
7. Reinstall **cover (2)** - before installation check the **cover gasket (3)** for damage, replace if necessary.

⚠ CAUTION

AFTER THE MACHINE IS TOWED THE COVER BOLTS (1) MUST BE REMOVED FROM THE BRAKE DISENGAGE HOLES (4). THE BRAKES CANNOT BE ENGAGED IF THE DISENGAGE BOLTS ARE LEFT IN THE DISENGAGE HOLES. THIS WILL CAUSE THE MACHINE TO ROLL WHEN PARKED ON AN INCLINE.

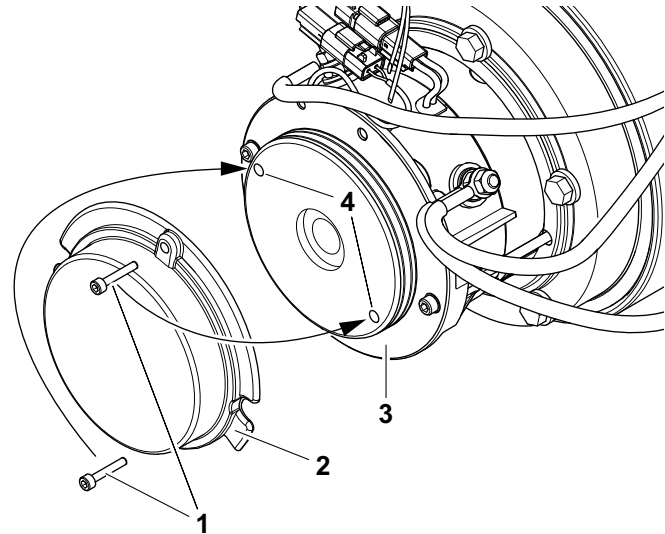

Figure 3-20. Brake - Manual Disengage.

SECTION 4. EMERGENCY PROCEDURES

4.1 GENERAL INFORMATION

This section explains the steps to be taken in case of an emergency situation during operation.

4.2 EMERGENCY OPERATION

Operator Unable to Control Machine

IF THE PLATFORM OPERATOR IS UNABLE TO OPERATE OR CONTROL THE MACHINE:

1. Other personnel should operate the machine from ground controls only as required.
2. Only qualified personnel in the platform may use the platform controls. **DO NOT CONTINUE OPERATION IF CONTROLS DO NOT FUNCTION PROPERLY.**
3. Rescue equipment can be used to remove the platform occupant(s). Cranes and forklifts can be used to stabilize motion of the machine.

Platform Caught Overhead

If the platform becomes jammed or snagged in overhead structures or equipment, rescue the platform occupant(s) prior to freeing the machine.

Righting of Tipped Machine

A fork truck of suitable capacity or equivalent equipment should be placed under the elevated side of the chassis, with a crane or other suitable lifting equipment used to lift the platform while the chassis is lowered by the forklift or other equipment.

4.3 PLATFORM MANUAL DESCENT

The platform manual descent control is used in the event of total power failure to retract and lower the platform using gravity. The manual descent control T-handle is located on the right rear of the machine, just in front of the drive wheel. Look for the instruction decal located beside the release handle.

The lowering procedure is as follows:

1. Locate the **manual descent control T-handle**.
(See Figure 4-2.)

⚠ WARNING

KEEP HANDS AND ARMS OUT OF THE PATH OF THE SCISSOR ARMS AND PLATFORM WHILE LOWERING.

2. Grasp the T-handle and slowly pull out to lower the scissor arms/platform, when the platform is lowered to desired level, allow the T-handle to return to its closed position.

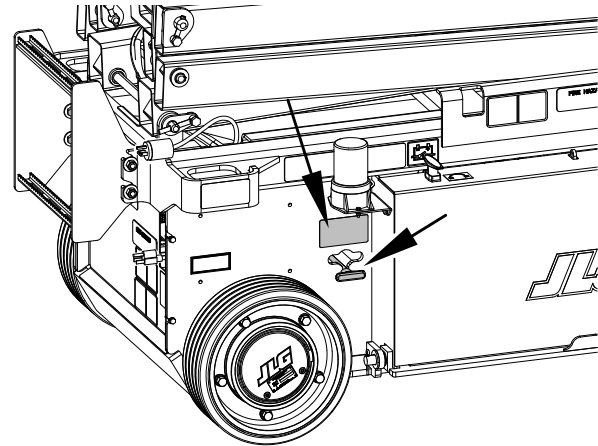
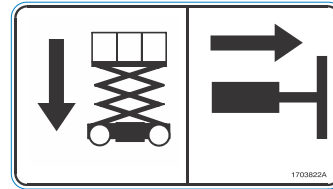

**Figure 4-1. R6 - Location of Manual Descent Control
(Right Rear of Machine)**

4.4 INCIDENT NOTIFICATION

JLG Industries, Inc. must be notified immediately of any incident involving a JLG product. Even if no injury or property damage is evident, JLG must be contacted by telephone and provided with all necessary details.

USA: 877-JLG-SAFE (554-7233)

EUROPE: (44) 1 698 811005

AUSTRALIA: (61) 2 65 811111

E-mail: productsafety@jlg.com

Failure to notify the manufacturer of an incident involving a JLG Industries product within 48 hours of such an occurrence may void any warranty consideration on that particular machine.

NOTICE

FOLLOWING ANY INCIDENT, THOROUGHLY INSPECT THE MACHINE. DO NOT ELEVATE PLATFORM UNTIL YOU ARE SURE THAT ALL DAMAGE HAS BEEN REPAIRED, AND THAT ALL CONTROLS ARE OPERATING CORRECTLY. TEST ALL FUNCTIONS FIRST FROM THE GROUND CONTROL STATION, THEN FROM THE PLATFORM CONTROL CONSOLE.

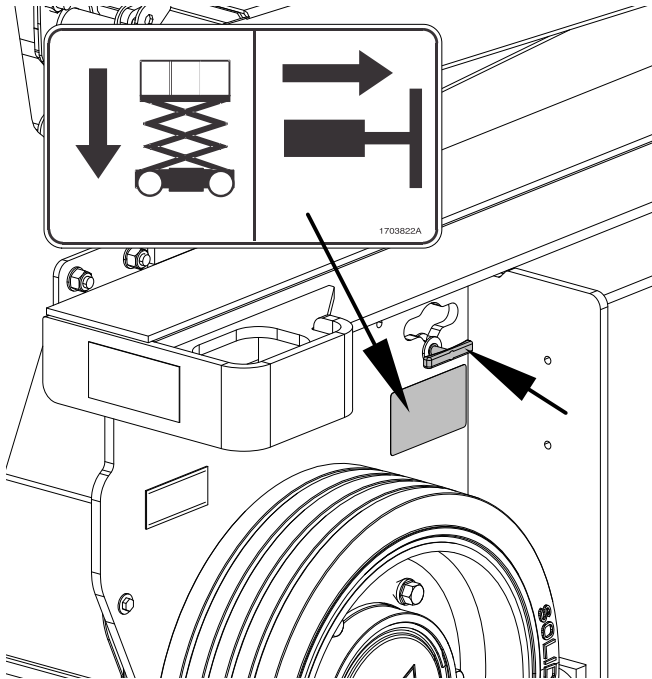

**Figure 4-2. R10 - Location of Manual Descent Control
(Right Rear of Machine)**

SECTION 5. GENERAL SPECIFICATIONS AND MAINTENANCE

5.1 INTRODUCTION

This section of the manual provides additional necessary information to the operator for proper operation and maintenance of this machine.

The maintenance portion of this section is intended as information to assist the machine operator to perform daily maintenance tasks only, and does not replace the more thorough Preventive Maintenance and Inspection Schedule included in the Service and Maintenance Manual.

Other Publications Available Specific to this Machine:

Service and Maintenance Manual	3121688
Illustrated Parts Manual	3121689

SECTION 5 - GENERAL SPECIFICATIONS AND MAINTENANCE

5.2 OPERATING SPECIFICATIONS

Table 5-1. Operating Specifications

DESCRIPTION	R6		R10
	Australia	ANSI	ANSI
PLATFORM			
Maximum Platform Height	18.5 ft. (5.64 m)	19 ft. (5.8 m)	32 ft. (9.75 m)
Platform Lift Time (seconds/no load)	Lift Up: Lift Down:	18-23 seconds 25-35 seconds	60 seconds 60 seconds
DRIVING			
Maximum Operating Tilt Angle (platform fully elevated)	(Grade) Front to Back: (Sideslope) Side to Side:	3° 1.5°	3° 2°
Maximum Drive Speed	Stowed: Elevated:	2.5 mph (4.0 kph) 0.6 mph (1.0 kph)	2.5 mph (4.0 kph) 0.6 mph (1.0 kph)
Maximum Stowed Travel Grade (Gradeability) (Reference Figure 3-12. on page 3-18)	25% (14°)		25% (14°)
Inside Turning Radius	23.6 in. (60 cm)		47.9 in. (121.7 cm)
Outside Turning Radius	87.9 in. (223 cm)		125.3 in. (318.1 cm)
CHASSIS			
Approximate Gross Machine Weight	3,500 lb. (1,588 kg)	3,000 lb. (1,361 kg)	5,180 lb. (2,350 kg)
Maximum Tire Load (per wheel)	1,365 lb. (620 kg)		2,070 lb. (939 kg)
Ground Bearing Pressure	130 psi (9.18 kg/cm ²)		92 psi (6.5 kg/cm ²)

SECTION 5 - GENERAL SPECIFICATIONS AND MAINTENANCE

Table 5-1. Operating Specifications (Continued)

DESCRIPTION		R6		R10
		Australia	ANSI	ANSI
Ground Clearance	PHP Retracted:	3.76 in. (9.55 cm)		4.6 in. (11.6 cm)
	PHP Deployed:	0.98 in. (2.5 cm)		0.9 in. (2.3 cm)
Break Over Angle (Grade)		15° (26.8%)		14° (25%)
Maximum Hydraulic Pressure	Main Relief:	2300 psi (159 bar)		2500 psi (172 bar)
	Steer Relief:	1000 psi (69 bar)		1000 psi (69 bar)
	Lift Relief:	2300 psi (159 bar)		2500 psi (172 bar)

Platform Capacities

Table 5-2. Platform Capacities

SPECIFICATION	MACHINE MODEL	MAXIMUM PLATFORM CAPACITY ⁽¹⁾	MAXIMUM CAPACITY ALLOWED ON PLATFORM EXTENSION	MAXIMUM PERSONS ALLOWED IN PLATFORM	MAX. SIDE FORCE (Platform Fully Extended @ Max. Capacity)	MAXIMUM OPERATING WIND SPEED
AUSTRALIA	R6	230 Kg	120 Kg	Indoor - 2 Persons + 70 Kg	400 N	0 m/s
				Outdoor - 1 Person + 150 Kg	200 N	12.5 m/s
ANSI	R6	500 lb. (227 Kg)	250 lb. (113 Kg)	2	100 lb. (445 N)	28 mph (12.5 m/s)
	R10	705 lb. (320 Kg)	250 lb. (113 Kg)	2	100 lb. (445 N)	28 mph (12.5 m/s)

NOTE: (1) Maximum Platform Capacity includes platform and platform extension.

SECTION 5 - GENERAL SPECIFICATIONS AND MAINTENANCE

Machine Dimensional Data

Table 5-3. Dimensions

DESCRIPTION	R6	R10
Platform Height - Elevated (Ground to Platform Floor)	18.5 ft. (5.64 m) - AUST 19 ft. (5.79 m) - ANSI	32 ft. (9.75 m)
Platform Height - Stowed (Ground to Platform Floor)	39.5 in. (100 cm)	54.4 in. (1.38 m)
Working Height	24 ft. 6 in. (7.47 m) - AUST 25 ft. (7.6 m) - ANSI	38 ft. (11.6 m)
Rail Height (Platform Floor to Top of Rail)	40 in. (101.6 cm)	44.7 in. (1.14 m)
Rail Height - Folded (Ground to Mid Rail)	N/A	77.6 in. (1.97 m)
Overall Machine Width	32 in. (81.2 cm)	48 in. (1.22 m)
Overall Machine Length	81.8 in. (208 cm)	90.6 in. (2.3 m)
Platform Size - Length	71.3 in. (182 cm)	84.9 in. (2.15 m)
Platform Size - Width	27.1 in. (68.9 cm)	42 in. (1.07 m)
Wheelbase	55 in. (1.40 m)	73 in. (1.85 m)

Tires

Table 5-4. Tire Specifications

DESCRIPTION	R6	R10
Size	12.7 in. x 3.9 in. (32.3 cm x 10.0 cm)	16 in. x 5 in. (40.6 cm x 12.7 cm)
Wheel Bolt Torque (M12x1.5 Wheel Bolt)	120 ft lb. (163 Nm)	120 ft lb. (163 Nm)

Batteries

Table 5-5. Battery Specifications

DESCRIPTION	R6/R10 MACHINES
Voltage (24V System - Series)	6V per battery
Amp Hour (Standard Battery)	220 Amp Hour @ 20 HR. Rate
Reserve Capacity (Standard Battery)	447 Minutes

Electrical System

Table 5-6. Electrical System Specifications

DESCRIPTION	ALL MACHINES
Electrical System Voltage (DC)	24V
Battery Charger:	
Input:	
AC Input Voltage:	85-265V AC
Nominal AC Input Voltage:	120VAC / 230VAC RMS
Input Frequency:	45 - 65Hz
Max. AC Input Current:	12A - RMS @ 108V AC
Ingress Protection:	IP46 NEMA4 Type 4
Operating Temperature:	-22°F (-30°C) to 122°F (+50°C)
Output:	
Nominal DC Output Voltage:	24V
Max. DC Output Voltage:	33.6V
Max DC Output Current:	25A
Max. Interlock Current:	1A
Protection:	
Output Reverse Polarity:	Electronic Protection-Auto Reset
Output Short Circuit:	Electronic Protection-Auto Reset
AC Overload:	Current Limited
DC Overload:	Current Limited

5.3 CRITICAL STABILITY WEIGHTS

⚠ WARNING

DO NOT REPLACE ITEMS CRITICAL TO STABILITY, SUCH AS BATTERIES OR SOLID TIRES, WITH ITEMS OF DIFFERENT WEIGHT OR SPECIFICATION. DO NOT MODIFY UNIT IN ANY WAY TO AFFECT STABILITY.

Table 5-7. Critical Stability Weights

COMPONENT	R6	R10
Wheel and Tire Assembly (each)		
Front:	21.6 lb. (9.8 kg)	43 lb. (19.5 kg)
Rear:	21.6 lb. (9.8 kg)	40.5 lb. (18.4 kg)
Wheel/Tire and Drive Assembly (each)	113 lb. (51.3 kg)	134 lb. (60.8 kg)
Batteries (each)	Standard: 62 lb. (28.1 kg) AGM: 65 lb. (29.5 kg)	62 lb. (28.1 kg) 65 lb. (29.5 kg)
Batteries (combined)	Standard: 248 lb. (111.1 kg) AGM: 260 lb. (118 kg)	248 lb. (111.1 kg) 260 lb. (118 kg)

SECTION 5 - GENERAL SPECIFICATIONS AND MAINTENANCE

5.4 LUBRICATION

Lubrication Capacities

Table 5-8. Capacities

COMPONENT	R6	R10
Hydraulic Reservoir	1.32 Gal. (5L)	2.38 Gal. (9L)
Hydraulic System (Including Reservoir)	1.85 Gal. (7L)	3.96 Gal. (15L)

Hydraulic Oil

Table 5-9. Hydraulic Oil

HYDRAULIC SYSTEM OPERATING TEMPERATURE RANGE	SAE VISCOSITY GRADE
0° F to +23° F (-18° C to -5° C)	10W
0° F to 210° F (-18° C to +99° C)	10W-20, 10W-30
50° F to 210° F (+10° C to +99° C)	20W-20

NOTE: Aside from JLG recommendations, it is not advisable to mix oils of different brands or types, as they may not contain the same required additives or be of comparable viscosities.

Lubrication Specifications

Table 5-10. Lubrication Specifications

KEY	SPECIFICATIONS
MPG	Multipurpose Grease having a minimum dripping point of 350° F. Excellent water resistance and adhesive qualities, and being of extreme pressure type. (Timken OK 40 pounds minimum.)
EPGL	Extreme Pressure Gear Lube (oil) meeting API service classification GL-5 or MIL-Spec MIL-L-2105.
HO	JLG Recommends - Mobil DTE 10 EXCEL 15 ATF - Automatic Transmission Fluid Mobil EAL ENVIRONSYNH32 Mobil EAL HYDRAULIC OIL 32

Table 5-11. Hydraulic Oil Specifications

SPECIFICATION	MOBIL DTE 10 EXCEL 15	MOBIL EAL ENVIRONSYN H 32
ISO Viscosity Grade	#15	#32
Spec Gravity API	31.9	0.950
Pour Point, Max	-65° F (-54° C)	-38° F (-39° C)
Flash Point, Min.	360° F (182° C)	514° F (268° C)
VISCOSITY SPECIFICATIONS		
at 40° C	15 cSt	33.1 cSt
at 100° C	4.1 cSt	6.36 cSt
at 100° F	80 SUS	—
at 210° F	43 SUS	—
cp at -30° F	3.2	—
Viscosity Index	168	147
Operating Temp	—	-20° F (-29° C) to 200° F (93° C)

1001102685_3

5.5 OPERATOR MAINTENANCE

Hydraulic Oil Check Procedure

Lube Point(s) - Hydraulic Reservoir

Reservoir Capacity - See Table 5-8 on page 5-6.

Lube - Hydraulic Oil

Interval - Check Daily

NOTE: Check the hydraulic oil level with the platform in the stowed position *ONLY*. Be certain the hydraulic oil has warmed to operating temperature before checking the oil level in the reservoir.

1. On the left side of the machine, remove the **side access door on the base frame**. Locate the **hydraulic oil reservoir (1)** on the **pump unit (2)**. Check the oil level in the hydraulic reservoir by looking at the markings on the side. The reservoir is marked with a **MAX (maximum) marking (3)**. The oil level must be kept at or within one (1) inch of this marking to operate properly.
2. If additional oil is required, wipe all dirt and debris from the **filler/breather cap (4)** area, add proper grade of oil. Fill until oil level is close to the **MAX marking (3)**, but not over the **MAX marking**.

NOTE: Care should be taken not to introduce any impurities (dirt, water, etc.) while cap is removed.

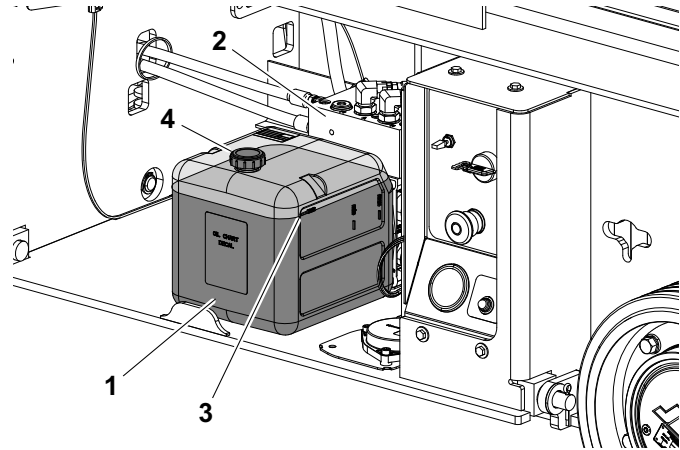

Figure 5-1. R6 - Hydraulic Oil Check Procedure

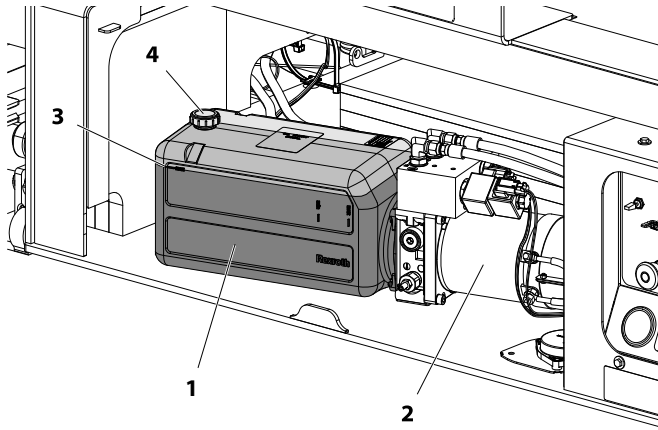

Figure 5-2. R10 - Hydraulic Oil Check Procedure

NOTE: Recommended lubricating intervals are based on machine operations under normal conditions. For machines used in multi-shift operations and/or exposed to hostile environments or conditions, lubrication frequencies must be increased accordingly.

5.6 BATTERY MAINTENANCE

Battery Maintenance and Safety Practices

NOTE: These instructions are for unsealed (wet) batteries only. If machine is equipped with sealed batteries, no maintenance other than cleaning corroded battery terminals is required.

⚠ CAUTION

ENSURE THAT BATTERY ACID DOES NOT COME INTO CONTACT WITH SKIN OR CLOTHING. WEAR PROTECTIVE CLOTHING AND EYEWEAR WHEN WORKING WITH BATTERIES. NEUTRALIZE ANY BATTERY ACID SPILLS WITH BAKING SODA AND WATER.

BATTERY ACID RELEASES AN EXPLOSIVE GAS WHILE CHARGING, ALLOW NO OPEN FLAMES, SPARKS OR LIGHTED TOBACCO PRODUCTS IN THE AREA WHILE CHARGING BATTERIES. CHARGE BATTERIES ONLY IN A WELL VENTILATED AREA.

ADD ONLY DISTILLED WATER TO BATTERIES. WHEN ADDING DISTILLED WATER TO THE BATTERIES, A NON-METALLIC CONTAINER AND/OR FUNNEL MUST BE USED.

Check the electrolyte level of the batteries often, adding only distilled water when required. When fully charged, battery fluid level should be 1/8" below vent tubes. (See Figure 5-3.).

- DO NOT fill to bottom of vent tubes.

SECTION 5 - GENERAL SPECIFICATIONS AND MAINTENANCE

- DO NOT allow fluid level to go below the top of the plates when charging or operating.

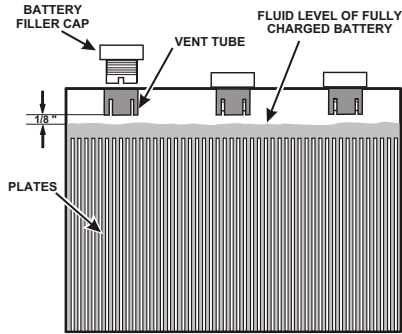
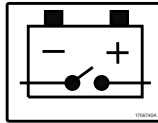

Figure 5-3. Battery Fluid Level.

Battery Quick-Disconnect - (If Equipped)

Machines equipped with the battery quick-disconnect allow all machine power to be easily disconnected at the batteries without removing battery cables from the battery posts. To disconnect power, locate the RED quick-disconnect connector on top of the batteries inside the battery compartment and pull halves apart.



5.7 TIRES AND WHEELS

Tire Wear and Damage

The tire and rim assemblies installed on RS machines have been approved by the tire manufacturer for applications in which those products are intended to be used. The tire and rims installed on each product model have been designed for stability requirements, which consist of track width, tire compound, and load capacity. Tire changes such as rim width, centerpiece location, larger or smaller diameter, tire compound, etc., without written manufacturers approval, could result in an unsafe condition regarding stability.

The tires and rims installed on RS machines are to be inspected daily as part of the daily walk-around inspection. JLG requires that the daily walk-around inspection be performed at each operator change during a shift and at each shift change.

Wheel and Tire Replacement

JLG recommends that any replacement tire be the same size and brand as originally installed on the machine or offered by JLG as an approved replacement. Please refer to the JLG Parts Manual for the part number of the approved tires for a particular machine model.

If any of the following is discovered during tire inspection, measures must be taken to remove the JLG product from service immediately. Arrangements must be made for replacement of the tire(s) or tire assembly(s). Both tires/wheels on the same axle must be replaced:

- If the overall diameter of the tire is less than one of the following:

100 x 323 Tire – 12.25 in. (311mm) minimum

127 x 406 Tire – 15.50 in. (394mm) minimum

- If any uneven wear is discovered.

A tire with significant damage in the tread area or sidewall requires immediate evaluation before placing the machine into service. If a cut, tear, chunk, or other discrepancy exceeds any one or more of the following dimensions, the tire must be replaced:

3.0 in. (76 mm) long

0.75 in. (19 mm) wide

0.75 in. (19 mm) deep

- If the metal wheel is visible at any point through the tread area of the tire.
- If more than one discrepancy exists in any quadrant of the wheel (within 90 degrees of one another).

Wheel Installation

It is extremely important to apply and maintain proper wheel mounting torque.

WARNING

WHEEL LUG NUTS MUST BE INSTALLED AND MAINTAINED AT THE PROPER TORQUE TO PREVENT LOOSE WHEELS, BROKEN LUG NUTS, AND POSSIBLE SEPARATION OF WHEEL FROM THE AXLE. BE SURE TO USE ONLY THE LUG NUTS MATCHED TO THE CONE ANGLE OF THE WHEEL.

Tighten the lug nuts to the proper torque to prevent wheels from coming loose. Use a torque wrench to tighten the fasteners. Over-tightening will result in breaking the lug nuts or permanently deforming the mounting holes in the wheel. The proper procedure for attaching wheels is as follows:

1. Start all lug nuts by hand to prevent cross threading. DO NOT use a lubricant on threads or nuts.
2. Tighten lug nuts in the following sequence. (See Figure 5-4.)
3. The tightening of the lug nuts should be done in stages. Following the recommended sequence, tighten lug nuts per wheel torque.
4. Wheel lug nuts should be torqued after the first 50 hours of operation and after each wheel removal.

SECTION 5 - GENERAL SPECIFICATIONS AND MAINTENANCE

Check torque every 3 months or 150 hours of operation.

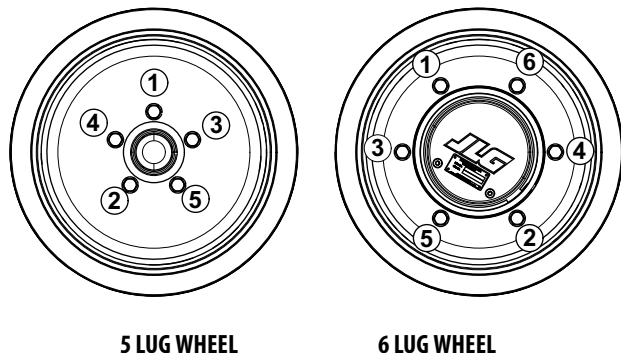

Figure 5-4. Wheel Lug Nut Tightening Sequence

Table 5-12. Wheel Torque Chart

TORQUE SEQUENCE		
1st Stage	2nd Stage	3rd Stage
20-30 ft. lb. (28-42 Nm)	65-80 ft. lb. (91-112 Nm)	105-120 ft. lb. (142-163 Nm)

5.8 SUPPLEMENTAL INFORMATION

The following information is provided in accordance with the requirements of the European Machinery Directive 2006/42/EC and is only applicable to CE machines.

For electric powered machines, the equivalent continuous A-Weighted sound pressure level at the work platform is less than 70dB(A).

For combustion engine powered machines, guaranteed Sound Power Level (LWA) per European Directive 2000/14/EC (Noise Emission in the Environment by Equipment for Use Outdoors) based on test methods in accordance with Annex III, Part B, Method 1 and 0 of the directive, is 109 dB.

The vibration total value to which the hand-arm system is subjected does not exceed 2,5 m/s². The highest root mean square value of weighted acceleration to which the whole body is subjected does not exceed 0,5 m/s².

5.9 DECAL INSTALLATION

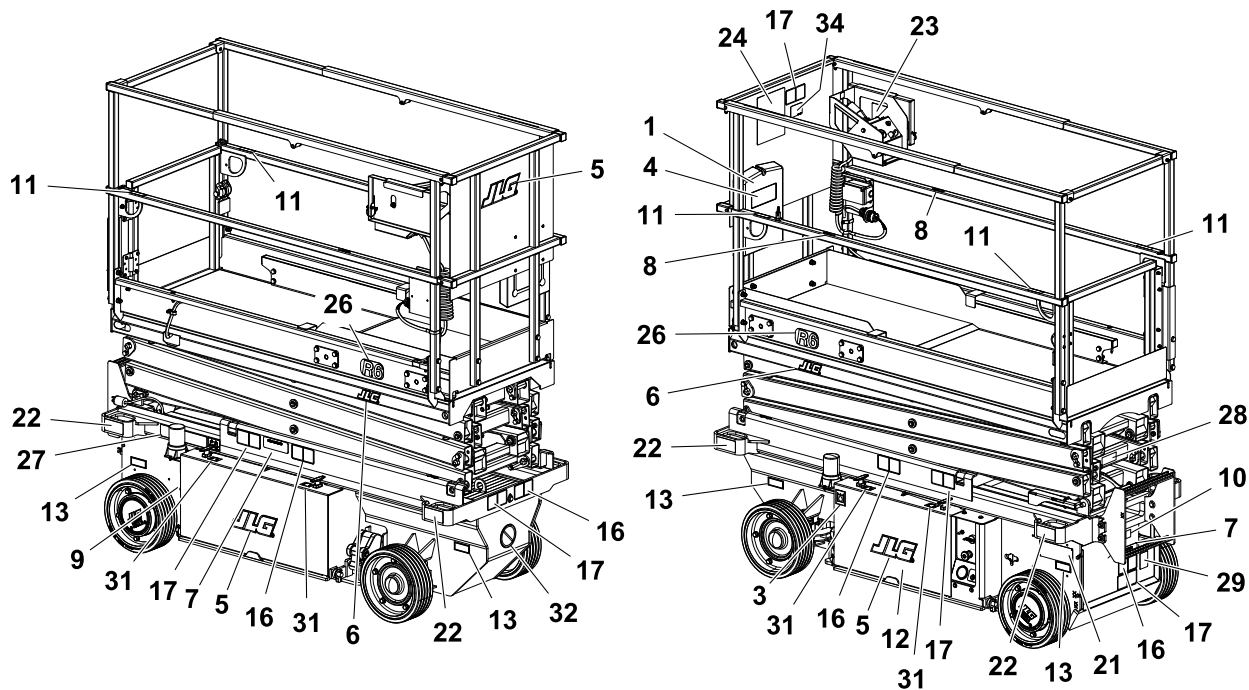

Figure 5-5. R6 (AUST) - Machine Decal Installation (See Table 5-13.)

SECTION 5 - GENERAL SPECIFICATIONS AND MAINTENANCE

Table 5-13. R6 (AUST) - Machine Decal Installation Chart

ITEM	AUSTRALIA (R6)
1	0860520
2	—
3	1701504
4	1701509
5	1705754
6	1703177
7	1705670
8	1703819
9	1703822
10	1704016
11	1704277
12	1704412 (on tank)
13	1705647
14	—
15	—
16	1705673
17	1705671
18	—
19	—

Table 5-13. R6 (AUST) - Machine Decal Installation Chart

ITEM	AUSTRALIA (R6)
20	—
21	1001127512
22	1001162864
23	1001132359
24	1001146902
25	—
26	1001182601
27	1001146794
28	1001137394
29	1001134280
30	—
31	1706350
32	1703072
33	—
34	1001092497

NOTE: Reference applicable Illustrated Parts Manual for decal description.

SECTION 5 - GENERAL SPECIFICATIONS AND MAINTENANCE

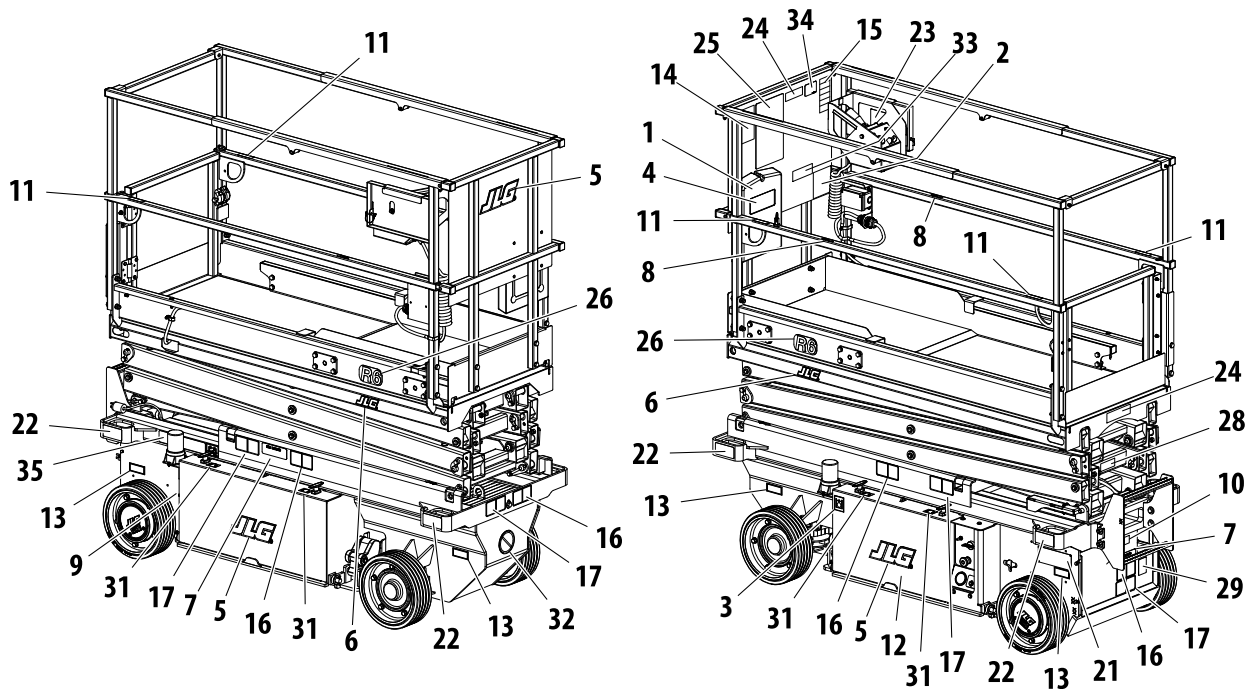

Figure 5-6. R6 (ANSI) - Machine Decal Installation (See Table 5-14.)

SECTION 5 - GENERAL SPECIFICATIONS AND MAINTENANCE

Table 5-14. R6 (ANSI) - Machine Decal Installation Chart

ITEM	ANSI (ENGLISH)	ANSI (LAT)	ANSI (BRZ)	ANSI (CHI)	ANSI (KOR)	(JAPAN)
1	0860520	0860520	0860520	0860520	0860520	0860520
2	1001131270	—	—	—	—	—
3	1701504	1701504	1701504	1701504	1701504	1701504
4	1701509	1701509	1701509	1701509	1701509	1701509
5	1705754	1705754	1705754	1705754	1705754	1705754
6	1703177	1703177	1703177	1703177	1703177	1703177
7	1703813	1704339	1704341	1704344	1703856	1705670
8	1703819	1703819	1703819	1703819	1703819	1703819
9	1703822	1703822	1703822	1703822	1703822	1703822
10	1704016	1704016	1704016	1704016	1704016	1704016
11	1704277	1704277	1704277	1704277	1704277	1704277
12	1704412 (<i>on tank</i>)	1704412 (<i>on tank</i>)	1704412 (<i>on tank</i>)	1704412 (<i>on tank</i>)	1704412 (<i>on tank</i>)	1704412 (<i>on tank</i>)
13	1705647	1705647	1705647	1705647	1705647	1705647
14	1705679	1705679	1705727	1705679	—	—
15	1705686	1705720	1705726	1705946	1706057	—
16	1705694	1705725	1705725	1705943	1706052	1705673
17	1705695	1705724	1703834	1705944	1706056	1705671
18	—	—	—	—	—	—
19	—	—	—	—	—	—

SECTION 5 - GENERAL SPECIFICATIONS AND MAINTENANCE

Table 5-14. R6 (ANSI) - Machine Decal Installation Chart

ITEM	ANSI (ENGLISH)	ANSI (LAT)	ANSI (BRZ)	ANSI (CHI)	ANSI (KOR)	(JAPAN)
20	—	—	—	—	—	—
21	1001115695	1001115695	1001115695	1001197050	1001115695	1001115697
22	1001162864	1001162864	1001162864	1001162864	1001162864	1001162864
23	1001132359	1001132359	1001132359	1001132359	1001132359	1001132359
24	1705699	1705699	1705699	1001146902	1705699	1705699
25	1001132376	1705719	1705719	1705945	1706053	1001132376
26	1001182601	1001182601	1001182601	1001182601	1001182601	1001182601
27	—	—	—	—	—	—
28	1001137394	1001137394	1001137394	1001137394	1001137394	1001137394
29	1001134280	1001134280	1001134280	1001134280	1001134280	1001134280
30	—	—	—	—	—	—
31	1706350	1706350	1706350	1706350	1706350	1706350
32	1703072	1703072	1703072	1703072	1703072	1703072
33	—	—	—	—	—	—
34	1001092071	1001120623	1001120623	1001120622	1001120621	1001092497
35	1001146794	1001146794	1001146794	1001146794	1001146794	1001146794

NOTE: Reference applicable Illustrated Parts Manual for decal description.

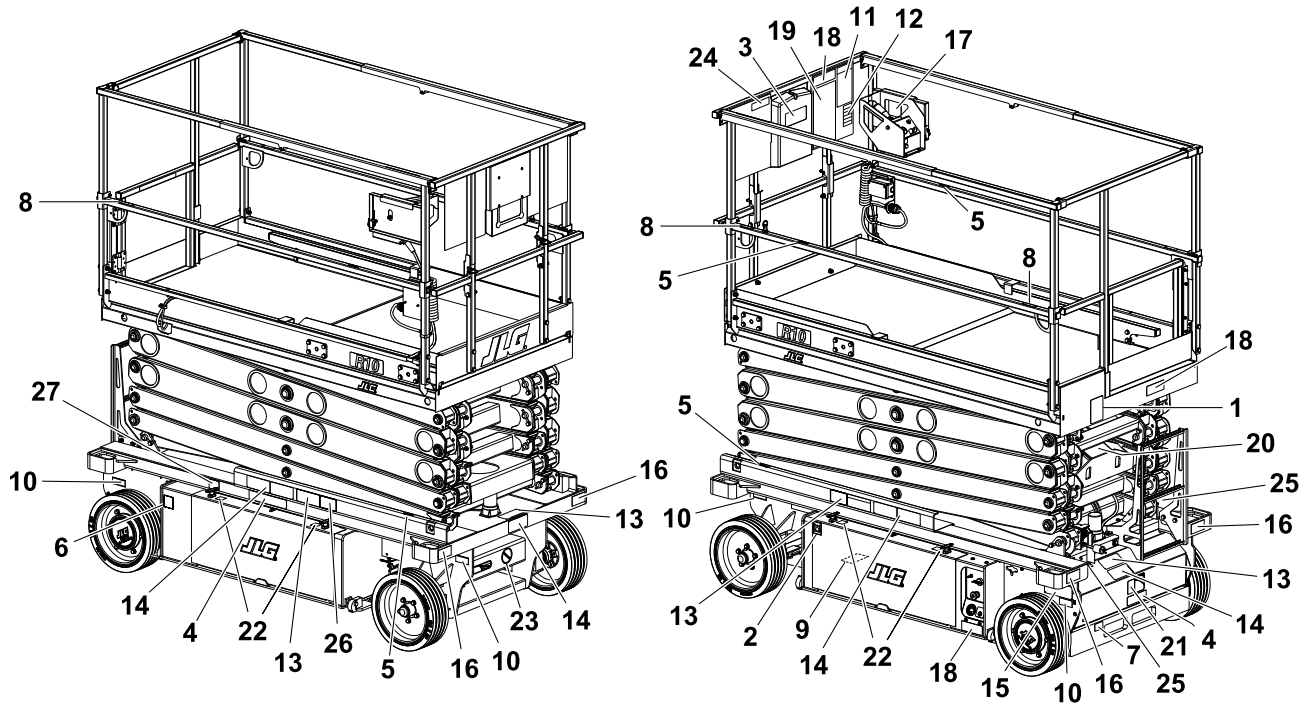

Figure 5-7. R10 (ANSI) - Machine Decal Installation (See Table 5-15.)

SECTION 5 - GENERAL SPECIFICATIONS AND MAINTENANCE

Table 5-15. R10 (ANSI) - Machine Decal Installation Chart

ITEM	ANSI	ANSI (LAT)	ANSI (BRZ)	ANSI (CHI)	ANSI (KOR)	(JAPAN)
1	1001131270	—	—	1001131270	—	—
2	1701504	1701504	1701504	1701504	1701504	1701504
3	1701509	1701509	1701509	1701509	1701509	1701509
4	1703813	1704339	1704341	1703813	1703856	1705670
5	1703819	1703819	1703819	1703819	1703819	1703819
6	1703822	1703822	1703822	1703822	1703822	1703822
7	1704016	1704016	1704016	1704016	1704016	1704016
8	1704277	1704277	1704277	1704277	1704277	1704277
9	1704412	1704412	1704412	1704412	1704412	1704412
10	1706311	1706311	1706311	1706311	1706311	1706311
11	1705679	1705679	1705727	1705679	1705679	—
12	1705686	1705720	1705726	1705686	1706057	—
13	1705694	1705694 1705725 (LAT)	1705722 1705725 (LAT)	1705694	1705694 1706052 (KOR)	1705673
14	1705695	1705695 1705724 (SPA)	1703834 (POR) 1705724 (SPA)	1705695	1705695 1706056 (KOR)	1705671
15	1001115695	1001115695	1001115695	1001115695	1001115695	1001115697
16	1001162864	1001162864	1001162864	1001162864	1001162864	1001162864

SECTION 5 - GENERAL SPECIFICATIONS AND MAINTENANCE

Table 5-15. R10 (ANSI) - Machine Decal Installation Chart

ITEM	ANSI	ANSI (LAT)	ANSI (BRZ)	ANSI (CHI)	ANSI (KOR)	(JAPAN)
17	1001132359	1001132359	1001132359	1001132359	1001132359	1001132359
18	1001132364	1001132364	1001132364	1001132364	1001132364	1001132364
19	1001132376	1001132376 1705719 (SPA)	1001132376 1705724 (POR)	1001132376	1001132376 1706053 (KOR)	—
20	1001133159	1001133159	1001133159	1001133159	1001133159	1001133159
21	1001134280	1001134280	1001134280	1001134280	1001134280	1001134280
22	1706350	1706350	1706350	1706350	1706350	1706350
23	1703072	1703072	1703072	1703072	1703072	1703072
24	1705303 (CSA)	—	—	—	—	—
25	1703464	1703464	1703464	1703464	1703464	3252507
26	1001146794	1001146794	1001146794	1001145794	1001146794	—
27	1706740	1706740	1706740	1706740	1706740	1706740

NOTE: Reference applicable Illustrated Parts Manual for decal description.

5.10 DIAGNOSTIC TROUBLE CODES (DTC)

The DTC tables following are sorted in groups by the first two digits, these digits represent the number of flashes the system distress indicator lamp will flash on the platform indicator panel when a fault occurs.

For example: a “2-1 Power-Up” on page 24 would be indicated by 2 flashes, a pause, then 1 flash, a pause, then would keep repeating until the fault is cleared.

The more detailed three digit code numbers in the DTC column of the following tables are only indicated on a JLG handheld diagnostic analyzer.

To troubleshoot multiple DTCs, start with the DTC with the higher first two digits.

If a correction is made during a check, conclude the check by cycling the machine power off then back on, using the emergency stop switch.

NOTICE

SHOULD A FAULT OCCUR WHICH CANNOT BE CORRECTED BY THE OPERATOR, THE PROBLEM MUST BE REFERRED TO A MECHANIC QUALIFIED TO REPAIR THIS MODEL OF JLG LIFT.

5.11 DTC CHECK TABLE INDEX

DTC	PAGE
0-0 Help Comments	5-23
2-1 Power-Up	5-24
2-2 Platform Controls	5-25
2-3 Ground Controls	5-26
2-4 Low/High Temperature Cutout	5-27
2-5 Function Prevented	5-27
3-1 Line Contactor Open Circuit	5-29
3-2 Line Contactor Short Circuit	5-30
3-3 Ground Output Driver	5-30
4-2 Thermal Limit (SOA)	5-32
4-4 Battery Supply	5-32
6-6 Communication	5-33
7-7 Electric Motor	5-33
8-1 Tilt Sensor	5-35
8-2 LSS - Load Sensing System	5-35
8-4 Elevation Switch	5-36
9-9 Hardware	5-37

5.12 DIAGNOSTIC TROUBLE CODES (DTC) CHECK TABLES

 0-0 Help Comments

DTC	FAULT MESSAGE	DESCRIPTION	CHECK
001	EVERYTHING OK	The normal help message in platform mode. Displays on the analyzer only.	
002	GROUND MODE OK	The normal help message in ground mode. Displays on the analyzer only.	
003	ALARM SOUNDING - TILTED & ABOVE ELEVATION	Control system senses that the platform is elevated and the vehicle is tilted, and the machine not configured to cutout.	<ul style="list-style-type: none"> • Check that the machine is tilted. If so, lower the platform and reposition the machine to a level surface. • Fully stow the platform. • The tilt sensor is part of the ground control box. Check that the ground control box is secured to the machine. • Check that the pothole protection switches are securely mounted and properly adjusted. • Check that the elevation angle sensor is securely mounted and properly adjusted. Refer problem to a qualified JLG mechanic.
004	DRIVING AT CUTBACK - ABOVE ELEVATION	The platform is elevated and the machine is in the driving in creep speed.	<ul style="list-style-type: none"> • Fully stow the platform. • Check that the elevation sensor is securely mounted. • Check that the pothole protection switches are securely mounted, and properly adjusted. Refer problem to a qualified JLG mechanic.

SECTION 5 - GENERAL SPECIFICATIONS AND MAINTENANCE

0-0 Help Comments

DTC	FAULT MESSAGE	DESCRIPTION	CHECK
005	DRIVE & LIFT UP PREVENTED - TILTED & ELEVATED	Driving is not possible since the platform is elevated and the chassis is not level.	<ul style="list-style-type: none">• Check that the machine is tilted. If so, lower the platform and reposition the machine to a level surface.• Fully stow the platform.• Check that the tilt sensor is securely mounted.• Check that the pothole protection switches are securely mounted.• Check that the elevation sensor is securely mounted. Refer problem to a qualified JLG mechanic.
007	DRIVING AT CUTBACK - POTHOLE STILL ENGAGED	While stowed, drive speed is reduced since the control system detected that the pothole protection mechanism failed to retract.	<ul style="list-style-type: none">• Check for obstructions around the pot-hole protection mechanisms.• Check that the PHP switches are securely mounted and adjusted. Refer problem to a qualified JLG mechanic.
008	FUNCTIONS LOCKED OUT - SYSTEM POWERED DOWN	After 2 hours without activity, the control system enters a low-power state to preserve battery charge.	<ul style="list-style-type: none">• Normal operation should resume after power is cycled off then back on.• Check batteries charge, condition, etc. Refer problem to a qualified JLG mechanic.

2-1 Power-Up

DTC	FAULT MESSAGE	DESCRIPTION	CHECK
211	POWER CYCLE	This help message is issued at each power cycle. Displays on the analyzer only.	Normal operation. No check necessary.

 **2-2 Platform Controls**

DTC	FAULT MESSAGE	DESCRIPTION	CHECK
221	FUNCTION PROBLEM - HORN PERMANENTLY SELECTED	The horn switch was closed during power-up in platform mode.	<ul style="list-style-type: none"> • Check if the horn switch is damaged, obstructed or jammed. Refer problem to a qualified JLG mechanic.
223	FUNCTION PROBLEM - DRIVE & LIFT ACTIVE TOGETHER	The drive and lift inputs are closed simultaneously in platform mode.	<ul style="list-style-type: none"> • Check drive/lift switch for visible damage. Refer problem to a qualified JLG mechanic.
224	FUNCTION PROBLEM - STEER LEFT PERMANENTLY SELECTED	The steer left switch was closed during power-up in platform mode.	<ul style="list-style-type: none"> • Check if the steer left switch is obstructed or jammed. Refer problem to a qualified JLG mechanic.
225	FUNCTION PROBLEM - STEER RIGHT PERMANENTLY SELECTED	The steer right switch was closed during power-up in platform mode.	<ul style="list-style-type: none"> • Check if the steer right switch is obstructed or jammed. Refer problem to a qualified JLG mechanic.
226	ACCELERATOR FAULTY - WIPER OUT OF RANGE	There is a problem with the joystick.	<ul style="list-style-type: none"> • Center joystick and check to see if a power cycle will clear DTC. Refer problem to a qualified JLG mechanic.
227	STEER SWITCHES FAULTY	The steer left and steer right inputs were closed simultaneously.	<ul style="list-style-type: none"> • Check if the steer switches are damaged, obstructed or jammed. Refer problem to a qualified JLG mechanic.
228	FUNCTION LOCKED OUT - ACCELERATOR NOT CENTERED	The joystick was not centered at power-up.	<ul style="list-style-type: none"> • Release joystick and allow to center. • Check if the joystick is obstructed or jammed. Refer problem to a qualified JLG mechanic.
229	FUNCTION PROBLEM - TRIGGER PERMANENTLY CLOSED	The trigger switch was closed during power-up in platform mode.	<ul style="list-style-type: none"> • Check if the trigger switch is obstructed or jammed. Refer problem to a qualified JLG mechanic.
2210	TRIGGER CLOSED TOO LONG WHILE IN NEUTRAL	The trigger switch was closed for more than five seconds while the joystick was centered.	<ul style="list-style-type: none"> • Check if the trigger switch is obstructed or jammed. Refer problem to a qualified JLG mechanic.

SECTION 5 - GENERAL SPECIFICATIONS AND MAINTENANCE

2-2 Platform Controls

DTC	FAULT MESSAGE	DESCRIPTION	CHECK
2232	FUNCTION PROBLEM - DRIVE & LIFT BOTH OPEN	The drive and lift inputs are both de-energized in platform mode.	<ul style="list-style-type: none">• Check if either function is active, if Yes; Refer problem to a qualified JLG mechanic.

2-3 Ground Controls

DTC	FAULT MESSAGE	DESCRIPTION	CHECK
231	FUNCTION PROBLEM - LIFT PERMANENTLY SELECTED	The ground control box lift switch was closed up or down, during power-up in ground mode.	<ul style="list-style-type: none">• Check if the lift switch is obstructed or jammed. Refer problem to a qualified JLG mechanic.
232	GROUND LIFT UP / DOWN ACTIVE TOGETHER	The lift up / down inputs are closed simultaneously.	<ul style="list-style-type: none">• Check if the lift switch is obstructed or jammed. Refer problem to a qualified JLG mechanic.
233	FUNCTION PROBLEM - BRAKE RELEASE PERMANENTLY SELECTED	The electric brake release switch was closed during power-up.	<ul style="list-style-type: none">• Check if the brake release switch is obstructed or jammed. Refer problem to a qualified JLG mechanic.

 **2-4 Low/High Temperature Cutout**

DTC	FAULT MESSAGE	DESCRIPTION	CHECK
241	AMBIENT TEMPERATURE SENSOR – OUT OF RANGE LOW	If elevated, drive and steer shall be restricted to “creep”. Lift down shall be allowed at normal speed, lift up shall not be allowed. The platform alarm shall continue to sound and the system distress indicator shall flash the appropriate DTC.	<ul style="list-style-type: none"> • The temperature as communicated by the temperature sensor located inside the ground control box is less than or equal to -50° C (-58° F). • Normal operation will resume when machine is warmed above -50° C (-58° F).
242	AMBIENT TEMPERATURE SENSOR – OUT OF RANGE HIGH	If stowed, drive, steer, and lift down shall be allowed at normal speed however lift up functionality shall be restricted. The platform alarm shall continue to sound and the system distress indicator shall flash the appropriate DTC.	<ul style="list-style-type: none"> • The temperature as communicated by the temperature sensor located inside the ground control box is greater than or equal to +125° C (+257° F). • Normal operation will resume when machine has cooled below +125° C (+257° F).

 **2-5 Function Prevented**

DTC	FAULT MESSAGE	DESCRIPTION	CHECK
253	DRIVE PREVENTED - CHARGER CONNECTED	Driving is not possible while the vehicle is charging.	<ul style="list-style-type: none"> • Check if the charger is connected to off board power source and disconnect if desired. Refer problem to a qualified JLG mechanic.
254	DRIVE & LIFT UP PREVENTED - CHARGER CONNECTED	Drive or lift is not possible while the vehicle is charging AND is configured to prevent all motion.	<ul style="list-style-type: none"> • Check if the charger is connected to off board power source and disconnect if desired. Refer problem to a qualified JLG mechanic.

SECTION 5 - GENERAL SPECIFICATIONS AND MAINTENANCE

2-5 Function Prevented

DTC	FAULT MESSAGE	DESCRIPTION	CHECK
255	PLATFORM OVERLOAD	The Load Sensing System (LSS) measured platform load is excessive.	<ul style="list-style-type: none">Remove excess weight from the platform.Check that platform is not caught on something, preventing up or down movement. Refer problem to a qualified JLG mechanic.
256	DRIVE PREVENTED - POT-HOLE NOT ENGAGED	Driving is not possible while elevated since the pot-hole protection system failed to deploy.	<ul style="list-style-type: none">Check for obstructions or mechanical problems around the pot-hole protection mechanisms.Check that the PHP switches are securely mounted. Refer problem to a qualified JLG mechanic.
258	DRIVE & LIFT PREVENTED - BRAKES ELECTRICALLY RELEASED FOR TOWING	Electric brake release mode is activated with the switch in the battery box near the ground control box. Drive or lift is not possible.	<ul style="list-style-type: none">Push manual brake release switch again or cycle power to clear manual brake release mode.Check if the brake release switch is obstructed or jammed. Refer problem to a qualified JLG mechanic.
259	MODEL CHANGED - HYDRAULICS SUSPENDED - CYCLE EMS	The model selection has been changed.	Refer problem to a qualified JLG mechanic.
2510	DRIVE PREVENTED - BRAKES NOT RELEASING	There is a problem with the drive or brake system.	<ul style="list-style-type: none">Ensure vehicle is not stuck on something preventing movement. Refer problem to a qualified JLG mechanic.

 **2-5 Function Prevented**

DTC	FAULT MESSAGE	DESCRIPTION	CHECK
2568	TEMPERATURE CUTOFF ACTIVE – AMBIENT TEMPERATURE TOO LOW	Reported if the ambient temperature reading by the machine's temperature sensor is less than -30°C (-22°F) the minimum allowed temperature as set by the LOW TEMP C/O personalities setting AND TEMPERATURE CUTOFF = YES.	<ul style="list-style-type: none"> • If elevated, drive and steer shall be restricted to “creep”, lift down shall be allowed at normal speed and lift up shall not be allowed. The platform alarm shall continue to sound and the system distress indicator shall flash the appropriate DTC. • If stowed, drive, steer, and lift down shall be allowed at normal speed however lift up functionality shall be restricted, the platform alarm shall continue to sound and the system distress indicator shall flash the appropriate DTC. • The ambient temperature must rise to greater than TEMP OFFSET from the LOW TEMP C/O point before interlocks and alarms are reset. <p>Refer problem to a qualified JLG mechanic.</p>

 **3-1 Line Contactor Open Circuit**

DTC	FAULT MESSAGE	DESCRIPTION	CHECK
311	OPEN CIRCUIT LINE CONTACTOR	There is a problem with the line contactor.	Refer problem to a qualified JLG mechanic.
314	AUXILIARY RELAY - OPEN CIRCUIT	The auxiliary relay did not close when energized.	<ul style="list-style-type: none"> • Check the auxiliary relay coil and the associated wiring. <p>Refer problem to a qualified JLG mechanic.</p>

SECTION 5 - GENERAL SPECIFICATIONS AND MAINTENANCE

3-2 Line Contactor Short Circuit

DTC	FAULT MESSAGE	DESCRIPTION	CHECK
321	LINE CONTACTOR MISWIRED ON OR WELDED	There is a problem with the line contactor.	Refer problem to a qualified JLG mechanic.
326	AUXILIARY RELAY - SHORT TO BATTERY	There is a problem with the auxiliary relay contacts or wiring.	Refer problem to a qualified JLG mechanic.

3-3 Ground Output Driver

DTC	FAULT MESSAGE	DESCRIPTION	CHECK
333	LIFT UP SHORT TO BATTERY	A problem has been detected in this function.	Refer problem to a qualified JLG mechanic.
334	LIFT UP OPEN CIRCUIT	A problem has been detected in this function.	Refer problem to a qualified JLG mechanic.
335	LIFT DN SHORT TO BATTERY	A problem has been detected in this function.	Refer problem to a qualified JLG mechanic.
336	LIFT DN OPEN CIRCUIT	A problem has been detected in this function.	Refer problem to a qualified JLG mechanic.
337	STEER LEFT SHORT TO BATTERY	A problem has been detected in this function.	Refer problem to a qualified JLG mechanic.
338	STEER LEFT OPEN CIRCUIT	A problem has been detected in this function.	Refer problem to a qualified JLG mechanic.
339	STEER RIGHT SHORT TO BATTERY	A problem has been detected in this function.	Refer problem to a qualified JLG mechanic.
3310	STEER RIGHT OPEN CIRCUIT	A problem has been detected in this function.	Refer problem to a qualified JLG mechanic.
3312	LEFT BRAKE SHORT TO BATTERY	A problem has been detected in this function.	Refer problem to a qualified JLG mechanic.
3313	RIGHT BRAKE SHORT TO BATTERY	A problem has been detected in this function.	Refer problem to a qualified JLG mechanic.

 **3-3 Ground Output Driver**

DTC	FAULT MESSAGE	DESCRIPTION	CHECK
3314	LEFT BRAKE OPEN CIRCUIT	A problem has been detected in this function.	Refer problem to a qualified JLG mechanic.
3315	RIGHT BRAKE OPEN CIRCUIT	A problem has been detected in this function.	Refer problem to a qualified JLG mechanic.
3349	LINE CONTACTOR COIL - SHORT TO GROUND	A problem has been detected in this function.	Refer problem to a qualified JLG mechanic.
33297	LEFT BRAKE - SHORT TO GROUND	A problem has been detected in this function.	Refer problem to a qualified JLG mechanic.
33298	STEER LEFT VALVE - SHORT TO GROUND	A problem has been detected in this function.	Refer problem to a qualified JLG mechanic.
33299	LINE CONTACTOR COIL - SHORT TO BATTERY	A problem has been detected in this function.	Refer problem to a qualified JLG mechanic.
33302	NEGATIVE SUPPLY - SHORT TO BATTERY	A problem has been detected in this function.	Refer problem to a qualified JLG mechanic.
33303	NEGATIVE SUPPLY - SHORT TO GROUND	A problem has been detected in this function.	Refer problem to a qualified JLG mechanic.
33304	RIGHT BRAKE - SHORT TO GROUND	A problem has been detected in this function.	Refer problem to a qualified JLG mechanic.
33305	STEER RIGHT VALVE - SHORT TO GROUND	A problem has been detected in this function.	Refer problem to a qualified JLG mechanic.
33383	BEACON LIGHT – SHORT TO GROUND	A problem has been detected with the beacon circuit.	Refer problem to a qualified JLG mechanic.
33384	BEACON LIGHT – OPEN CIRCUIT	A problem has been detected with the beacon circuit.	Refer problem to a qualified JLG mechanic.
33406	LIFT UP VALVE - SHORT TO GROUND	A problem has been detected in this function.	Refer problem to a qualified JLG mechanic.
33407	LIFT DN VALVE - SHORT TO GROUND	A problem has been detected in this function.	Refer problem to a qualified JLG mechanic.
33562	BEACON LIGHT – SHORT TO BATTERY	A problem has been detected in this function.	Refer problem to a qualified JLG mechanic.

SECTION 5 - GENERAL SPECIFICATIONS AND MAINTENANCE

4-2 Thermal Limit (SOA)

DTC	FAULT MESSAGE	DESCRIPTION	CHECK
421	POWER MODULE TOO HOT - PLEASE WAIT	The power module has reached thermal cut-out.	<ul style="list-style-type: none">• Power down and allow to cool.• Do not operate in ambients over 140° F (60° C). Refer problem to a qualified JLG mechanic.
422	DRIVING AT CUTBACK - POWER MODULE CURRENT LIMIT	The drive portion of the power module has reached thermal limit.	Refer problem to a qualified JLG mechanic.
423	LIFT UP AT CUTBACK - POWER MODULE CURRENT LIMIT	The lift up portion of the power module has reached thermal limit.	Refer problem to a qualified JLG mechanic.

4-4 Battery Supply

DTC	FAULT MESSAGE	DESCRIPTION	CHECK
441	BATTERY VOLTAGE TOO LOW - SYSTEM SHUTDOWN	A problem has been detected with the batteries or power module.	<ul style="list-style-type: none">• Recharge batteries or check for damaged batteries.• Check battery charger function. Refer problem to a qualified JLG mechanic.
442	BATTERY VOLTAGE TOO HIGH - SYSTEM SHUTDOWN	A problem has been detected with the batteries or power module.	<ul style="list-style-type: none">• May be due to improper battery charging or incorrect voltage batteries being used. Refer problem to a qualified JLG mechanic.
446 4421 4422	LOGIC SUPPLY VOLTAGE OUT OF RANGE	The System Module logic supply voltage was measured to be out of normal operating range.	<ul style="list-style-type: none">• Check for severely discharged battery, loose cables or for damaged battery; otherwise; Refer problem to a qualified JLG mechanic.

 **6-6 Communication**

DTC	FAULT MESSAGE	DESCRIPTION	CHECK
661	CANBUS FAILURE- POWER MODULE	The control system failed to receive messages from the power module.	Refer problem to a qualified JLG mechanic.
6643	CANBUS FAILURE- LSS ANGLE SENSOR	The control system failed to receive messages from the angle sensor.	Refer problem to a qualified JLG mechanic.
6649	CANBUS FAILURE – TILT/TEMP SENSOR	The control system failed to receive messages from the tilt sensor.	<ul style="list-style-type: none"> • Tilt Sensor CAN communication not received for 1000ms AND [Machine Setup's market configuration is AUSTRALIA OR Low Temperature Cutout is configured]. • Vehicle assumed to be elevated and tilted. • Tilt Sensor considered to be unhealthy if Australian Market. Temp Sensor considered to be unhealthy if Low Temperature Cutout configured. • Health Indicator On Refer problem to a qualified JLG mechanic.

 **7-7 Electric Motor**

DTC	FAULT MESSAGE	DESCRIPTION	CHECK
772	STALLED TRACTION MOTOR OR POWER WIRING ERROR	The power module detected a problem in the drive motors' power circuit wiring.	Refer problem to a qualified JLG mechanic.
773	CAPACITOR BANK FAULT - CHECK POWER CIRCUITS	The power module detected a problem in the pump or drive motors' power circuit wiring.	Refer problem to a qualified JLG mechanic.

SECTION 5 - GENERAL SPECIFICATIONS AND MAINTENANCE

7-7 Electric Motor

DTC	FAULT MESSAGE	DESCRIPTION	CHECK
774	SHORT CIRCUIT FIELD WIRING	The power module detected a problem in the drive motors' power circuit wiring.	Refer problem to a qualified JLG mechanic.
775	OPEN CIRCUIT FIELD WIRING	The power module detected a problem in the drive motors' power circuit wiring.	Refer problem to a qualified JLG mechanic.
776	STALLED PUMP MOTOR OR POWER WIRING ERROR	The power module detected a problem in the drive motors' power circuit wiring.	Refer problem to a qualified JLG mechanic.
777	OPEN CIRCUIT PUMP MOTOR WIRING	The power module detected a problem in the drive motors' power circuit wiring.	Refer problem to a qualified JLG mechanic.
778	TRACTION T HIGH - CHECK POWER CIRCUITS	The power module detected a problem in the drive motors' power circuit wiring.	Refer problem to a qualified JLG mechanic.
779	TRACTION T LOW - CHECK POWER CIRCUITS	The power module detected a problem in the drive motors' power circuit wiring.	Refer problem to a qualified JLG mechanic.
7710	PUMP P HIGH - CHECK POWER CIRCUITS	The power module detected a problem in the drive motors' power circuit wiring.	Refer problem to a qualified JLG mechanic.
7711	PUMP P LOW - CHECK POWER CIRCUITS	The power module detected a problem in the drive motors' power circuit wiring.	Refer problem to a qualified JLG mechanic.
7741	ARMATURE BRAKING CURRENT TOO HIGH	The power module has detected excessive braking current.	This can be caused by transporting an excessive load on a steep grade.

 **7-7 Electric Motor**

DTC	FAULT MESSAGE	DESCRIPTION	CHECK
7742	FIELD VOLTAGE IMPROPER	The power module detected a problem in the drive motors' power circuit wiring.	Recycle power on/off, if problem persists; Refer problem to a qualified JLG mechanic.

 **8-1 Tilt Sensor**

DTC	FAULT MESSAGE	DESCRIPTION	CHECK
811	TILT SENSOR NOT CALIBRATED	The chassis tilt sensor has never been calibrated. Vehicle assumed tilted and drive speed reduced.	Refer problem to a qualified JLG mechanic.

 **8-2 LSS - Load Sensing System**

DTC	FAULT MESSAGE	DESCRIPTION	CHECK
8212	LSS PRESSURE SENSOR - DISAGREEMENT	Pressure Sensor 1 and Pressure Sensor 2 do not agree. The system shall assume the machine is overloaded until the sensors agree.	Refer problem to a qualified JLG mechanic.
8213	LSS ANGLE SENSOR - DISAGREEMENT	The angle sensor's change in reading does not agree with the direction of the machine motion (lift up).	Refer problem to a qualified JLG mechanic.

SECTION 5 - GENERAL SPECIFICATIONS AND MAINTENANCE

8-2 LSS - Load Sensing System

DTC	FAULT MESSAGE	DESCRIPTION	CHECK
8214	LSS ANGLE SENSOR-DIRECTION DISAGREEMENT	The angle sensor's reading when the machine is at maximum elevation does not fall within the high end acceptable range.	Refer problem to a qualified JLG mechanic.
8215	LSS ANGLE SENSOR-OUT OF RANGE LOW	The angle sensor's reading when the machine is stowed does not fall within the low end acceptable range.	Refer problem to a qualified JLG mechanic.
8216	LSS ANGLE SENSOR HAS NOT BEEN CALIBRATED	The Angle Sensor has never been calibrated and the control system assumes that the platform is overloaded.	Refer problem to a qualified JLG mechanic.
825	LSS HAS NOT BEEN CALIBRATED	The load sensing system has never been calibrated. Platform assumed to be overloaded.	Refer problem to a qualified JLG mechanic.

8-4 Elevation Switch

DTC	FAULT MESSAGE	DESCRIPTION	CHECK
84109	ELEVATION SWITCH CONTACTS DISAGREEMENT	The elevation switch is repeating an incorrect value.	Refer problem to a qualified JLG mechanic.

 **9-9 Hardware**

DTC	FAULT MESSAGE	DESCRIPTION	CHECK
995	POWER MODULE FAILURE - PERSONALITY RANGE ERROR	A problem has been detected with the power module.	Refer problem to a qualified JLG mechanic.
996	POWER MODULE FAILURE - INTERNAL ERROR	A problem has been detected with the power module.	Refer problem to a qualified JLG mechanic.
998	EEPROM FAILURE - CHECK ALL SETTINGS	The control system detected an EEPROM failure.	Refer problem to a qualified JLG mechanic.
999	FUNCTION LOCKED OUT - POWER MODULE SOFTWARE VERSION IMPROPER	The power module software version is not compatible with the rest of the system.	Refer problem to a qualified JLG mechanic.
9924	FUNCTIONS LOCKED OUT – MACHINE NOT CONFIGURED	The system module has not been configured.	Refer problem to a qualified JLG mechanic.

SECTION 5 - GENERAL SPECIFICATIONS AND MAINTENANCE

9-9 Hardware

DTC	FAULT MESSAGE	DESCRIPTION	CHECK
9950 9951 9952 9953 9954 9955 9956 9957 9958 9960 9962 9963 9964 9969 9970 9971 99143 99144 99145 99146 99147 99148 99149	POWER MODULE FAILURE - INTERNAL ERROR	A problem has been detected with the power module.	Cycle machine power on /off a few times if this doesn't clear the DTC, refer problem to a qualified JLG mechanic.

PROPOSITION 65 WARNING

- **Battery posts, terminals and related accessories contain lead and lead compounds, chemicals known to the State of California to cause cancer and reproductive harm.**
- **Batteries also contain other chemicals known to the State of California to cause cancer.**
- **Wash hands after handling.**



An Oshkosh Corporation Company

JLG Industries, Inc.
1 JLG Drive
McConnellsburg PA. 17233-
9533
USA

(717) 485-5161

(717) 485-6417



3121687

JLG Worldwide Locations

JLG Industries (Australia)

P.O. Box 5119
11 Bolwarra Road
Port Macquarie
N.S.W. 2444

Australia

+61 2 65 811111

+61 2 65 813058

JLG Latino Americana Ltda.

Rua Eng. Carlos Stevenson,
80-Suite 71
13092-310 Campinas-SP
Brazil

+55 19 3295 0407

+55 19 3295 1025

JLG Industries (UK) Ltd

Bentley House
Bentley Avenue
Middleton
Greater Manchester
M24 2GP - England

+44 (0)161 654 1000

+44 (0)161 654 1001

JLG France SAS

Z.I. de Fauillet
47400 Tonneins
France

+33 (0)5 53 88 31 70

+33 (0)5 53 88 31 79

JLG Deutschland GmbH

Max-Planck-Str. 21
D - 27721 Ritterhude - Ihlpohl
Germany

+49 (0)421 69 350 20

+49 (0)421 69 350 45

JLG Equipment Services Ltd.

Rm 1107 Landmark North
39 Lung Sum Avenue
Sheung Shui N. T.
Hong Kong

(852) 2639 5783

(852) 2639 5797

JLG Industries (Italia) s.r.l.

Via Po. 22
20010 Pregnana Milanese - MI
Italy

+39 029 359 5210

+39 029 359 5845

Oshkosh - JLG Singapore T. E. P. Ltd.

29 Tuas Ave 4
Jurong Industrial Estate
639379
Singapore

+65-6591-9030

+65-6591-9031

Plataformas Elevadoras

JLG Iberica, S.L.
Trapadella, 2
P.I. Castellbisbal Sur
08755 Castellbisbal, Barcelona

Spain

+34 93 772 4700

+34 93 771 1762

JLG Sverige AB

Enkopingsvagen 150
Box 704
SE - 176 27 Jarfalla
Sweden

+46 (0)850 659 500

+46 (0)850 659 534