

# **karma**

A Better Wheelchair, A Better Fit

## *Powered Wheelchair Owner's Manual*

### Leon Series

(LEN Sling Seat/LEN Captain Seat/KISS Seat)

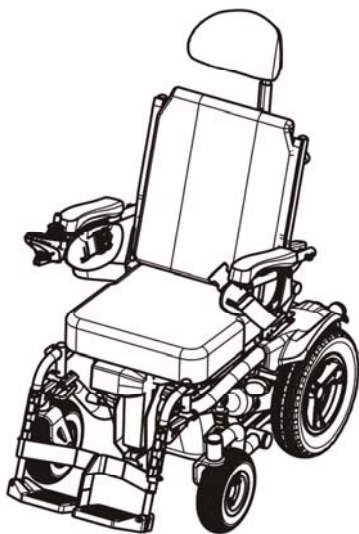

CE



---

## GENERAL WARNING

### IMPORTANT

Do not attempt to use the wheelchair before a qualified person has explained to your satisfaction how to operate it without risk to yourself or others.



#### WARNING

Do not operate this powered wheelchair before first reading and understanding this owner's manual. If you are unable to understand the warnings, cautions, suggestions and technical instructions, please contact a dealer, healthcare professional or applicable personnel before attempting to use this powered wheelchair -- otherwise, injury or damage may occur. If any procedure other than those described in this owner's manual, it must be performed by a qualified technician.

THE INFORMATION CONTAINED IN THIS DOCUMENT IS SUBJECT TO CHANGE WITHOUT NOTICE BY KARMA.



#### WARNING

As a manufacturer of powered wheelchairs, KARMA endeavors to supply a wide variety of powered wheelchairs to meet the many needs of the user. However, the responsibility of final selection of the type of powered wheelchair to be used by an individual rests solely with the user and his/her healthcare professional capable of making such a selection. KARMA strongly recommends consulting a certified rehab technology supplier or assistive technology professional.

### Operating Information

- Performance adjustments should ONLY be made by professionals of the healthcare field or persons fully conversant with this process and the driver's capabilities. Incorrect settings could cause injury to the driver or bystanders and damage to the powered wheelchair and surrounding property.
- To determine and establish your particular safety limits, practice bending, reaching, mounting and dismounting activities in several combinations in the presence of a qualified healthcare professional BEFORE attempting active use of the powered wheelchair.

- 
- For individuals with balance problems, practice mounting and dismounting activities WITH AN ASSISTANT in the presence of a qualified healthcare professional.
  - If anti-tippers are standard equipment, DO NOT operate the wheelchair without anti-tippers being installed. Anti-tippers MUST BE attached at all times.
  - DO NOT attempt to reach objects if you have to move forward in the seat or pick them up from the floor by reaching down between your knees as this may cause loss of balance.
  - DO NOT lean over the back of the chair to reach objects behind you as this may cause the powered wheelchair to tip over.
  - DO NOT shift your weight or sitting position toward the direction you are reaching as the powered wheelchair may tip over.
  - DO NOT use an escalator to move a powered wheelchair between floors. Serious bodily injury may occur.
  - DO NOT operate in car lanes on roads, streets, highways, etc.
  - DO NOT attempt to move up or down an incline with water, ice or oil film.
  - DO NOT make sharp turns, in forward or reverse, at excessive speeds.
  - DO NOT attempt to lift the powered wheelchair by its casings and seat.
  - DO NOT attempt to lift the powered wheelchair by any detachable parts. Lifting by means of any detachable parts of a powered wheelchair may result in injury to the user or damage to the powered wheelchair. Please hold onto the frame when lifting your wheelchair.
  - DO NOT operate the powered wheelchair until you have checked that the surroundings are clear and that the area is safe for travel.
  - Please pay attention to the environment, and to keep away from the hazard of external flame in spite of the seat having passed EN 1021-1/-2 test and

---

battery terminal caps having passed V-0 (UL94) test. When the user is smoking, pay attention to safety and make sure to extinguish the fire when finished. Be alert to the environment when someone nearby is smoking or using a cigarette lighter, keep away from the hazard and use fire-proof cloth.

- DO NOT use parts, accessories or adapters other than those authorized by Karma. Before attempting to sit in or exit the powered wheelchair, turn the power OFF. This will ensure that the powered wheelchair will not drive. Turn the power OFF while the wheelchair is not in use. Otherwise, injury and/or damage to the wheelchair and surrounding property may occur
- DO NOT connect any medical device (i.e., a ventilator, life support machine, et cetera) to the battery. This could cause unexpected failure of the device and the powered wheelchair. KARMA specifically disclaims responsibility to all personal injury and property damage that may occur during use which does not comply with applicable federal, state and local laws and ordinances.
- DO NOT stand on the footplates of the powered wheelchair.
- DO NOT use the wheelchair when the back is folded. This alters the centre of gravity and may cause the wheelchair to tip backwards. The back should only be folded for storage or transport of the wheelchair.
- DO NOT hang anything on the backjoints that could cause the backrest folding suddenly and may cause injury.
- DO NOT be towed by other vehicles(cars, motorcycles or bicycles, etc.). Only use freewheel mode on flat surfaces since your electromagnetic brakes are not engaged in this mode, without these brakes it will roll down a hill causing injury or damage. Never drive under the influence of alcohol or medication.
- DO NOT sit in the powered wheelchair within a moving vehicle unless it has been affixed the labels of hook mark.



## WARNING

- The wheelchair cannot be used as seats in any vehicles. That is, KARMA recommends that users are NOT transported in any vehicle while seated in the wheelchair. In the case of accident or a sudden stop, the user could be thrown from the wheelchair and get injured. The suggested solution is to transfer the user from the wheelchair into a normal seat of the vehicle and to securely stow the wheelchair in a separate compartment.

- DO NOT touch the surface of motors. It could be hot.
- Store your chair in a clean, dry area. If you fail to do so, parts may rust or corrode.
- The product meets all the requirements of ISO 7176-14.
- The force necessary to operate the freewheel lever is less than 60N.
- We estimate a life expectancy of five years for the product, provide it is used strict accordance with the intended use as set out in this document and all maintenance and service requirements are met. The estimated life expectancy can be exceeded if the products is carefully used and properly maintained. The life expectancy can be reduced by extreme or incorrect usage.

## RAMPS

- DO NOT climb, go up or down ramps or traverse slopes greater than the safe climbing angle for your model specified in Section 10. Specifications.
- When negotiating ramps, if the joystick is released while moving forward, the powered wheelchair will roll backwards approximately one foot before the brake engages. If the joystick is released while in reverse, the powered wheelchair will roll backwards approximately two and a half feet before the brake engages.
- Be sure to reduce your speed when driving on curved roads or making a turn; do not drive at full speed. Please drive at a slower speed so you have complete control of the wheelchair.

## ELECTRICAL

- Check to ensure that all electrical connections are secure at all times.

- 
- Grounding Instructions: DO NOT, under any circumstances, cut or remove the round grounding prong from any plug. Some devices are equipped with three-prong (grounding) plugs for protection against possible shock hazards.
  - Where a two-prong wall receptacle is encountered, it is the personal responsibility and obligation of the customer to contact a qualified electrician and have the two-prong receptacle replaced with a properly grounded three-prong wall receptacle/outlet in accordance with the National Electrical Code and local laws.
  - Do not use an extension cord when charging your batteries. A risk of fire and /or electric shock could be encountered.

## **BATTERIES**

- The warranty and performance specifications contained in this manual are based on the use of deep cycle sealed lead acid batteries. KARMA strongly recommends their use as the power source for this unit. (Refer to chapter 6)
- Carefully read the battery and charger information prior to installing, servicing or operating your wheelchair.

## **RAIN TEST**

- KARMA has tested its powered wheelchair in accordance with ISO 7176 Part 9 Rain Test. This test provides the end user or his/her attendant sufficient time to remove his/her powered wheelchair from a rainstorm and retain operation. However, the Leon series is not designed for usage in rain or storms or under other circumstances where it may be exposed to high levels of moisture , such as:
  - deep pools of water
  - pressure washing of the chair
  - leaving the chair in moist areas such as bathrooms

- 
- Direct exposure to rain or dampness could cause the powered wheelchair to malfunction electrically and mechanically and may cause the powered wheelchair to prematurely rust.
  - Salt water can be particularly damaging to the wheelchair components and electrical circuits, causing rust or damage.
  - Do not use the chair if the joystick rubber boot is damaged in any way as moisture can damage the control system.
  - Should your chair should get wet, please dry it as soon as possible to help avoid any damage.



Figure 1

## STAIRWAYS

- DO NOT attempt to move an occupied powered wheelchair between floors using a stairway. **(See Figure 1)**
- Use an elevator to move an occupied powered wheelchair between floors. When it's necessary to move the chair between floors by means of a stairway, the occupant **MUST** be moved and transported independently of the powered wheelchair. Extreme caution is advised when it is necessary to move an UNOCCUPIED powered wheelchair up or down stairs.
- Karma recommends disassembling the wheelchair and transporting the components independently up or down stairs. Make sure to use **ONLY** secure, non-detachable parts on each component for hand-hold supports.
- DO NOT attempt to lift a powered wheelchair by any removable (detachable) parts. Lifting by means of removable (detachable) parts may result in injury to the user or assistants or damage to the wheelchair.

## ESCALATOR

- DO NOT use an escalator to move a powered wheelchair between floors. Serious bodily injury and damage to the wheelchair may occur.

---

## YOU AND YOUR KARMA SERVICE PROVIDER

- No tools are required for assembly. Your wheelchair should be assembled by your authorized Karma dealer. Your authorized Karma dealer is also your service provider. Unauthorized repairs, upgrades and add-ons will void your warranty.
- Anything wheelchair related that requires tools should be done by your authorized Karma service provider. Your Karma service provider has the necessary service manual for your wheelchair.
- If you have any defective parts or lose any parts, please contact your dealer for repair and/or replacement. Please only use parts authorized by Karma. Use of parts that are not authorized by Karma will void your warranty.
- Part numbers are listed on our bill of materials (explosion drawings), which we give to our authorized dealers and service providers. Customers should order parts through their dealer as well as all repairs and scheduled maintenance.
- Customers should go to their dealership for all service needs to guarantee their warranty is not void. Always go to an authorized service provider. Unauthorized repairs will void your warranty. Procedures other than those described in this manual must be performed by a qualified technician. They also have the service manual with a complete list of maintenance required to keep your Karma wheelchair in top performance.
- Check the warranty section of this manual to find out what Karma guarantees and the maintenance service and parts that are not covered by the warranty.
- Karma does not have an official list of service providers at this time. Please contact your dealer for service. If you cannot contact your dealer, please contact another authorized Karma dealer for service. If all else fails, contact Karma directly via our website or give us a call and we can refer you to your new service provider.

## CLASSIFICATION & INTENDED USE

- Karma Leon series are classified as a class B mobility product for indoor and

---

outdoor use. It is designed for an individual with mobility disabilities.

- This wheelchair is suitable for one single user up to 140 kg in weight. It also has an extremely durable aluminum and iron frame with safe accessories that provides consistent performance even in dramatic extremes of temperature (neither the user nor the attendant need to touch any metal parts in normal use).
- Check with your local government as to legislation pertaining to mobility vehicles to assure your legal requirements to drive on public roads have been met, i.e. a pelvic belt, lighting, registration or licensing.

## CE MARKING

- This powered wheelchair complies with the requirements of the Medical Devices Directive 93/42/EEC.



### CAUTION

- Before purchasing and using Karma wheelchairs, please consult qualified professionals so as to ensure that you choose suitable products and use them correctly as well. For safety reasons, if there is any risk due to the user's movement in the wheelchair or other environmental factors that might cause the wheelchair to tip or the person on the wheelchair to fall off, Karma recommends that you install anti-tippers, pelvic belt, or other additional safety accessories.



### WARNING

When prescribing wheelchairs for use by full or partial amputees (above or below knee, single or double) or other conditions that affects the user's natural centre of gravity and might cause the wheelchair to tip or the person on the wheelchair to fall off, we suggest contacting your therapist or dealer as well as attaching anti-tippers, pelvic belt, safety belt, or other additional safety accessories.

When using the wheelchair, ALWAYS follow the Highway Code or your local traffic regulations when outdoors and the guidelines written in this manual.

## TABLE OF CONTENTS

1. PREFACE.....	1
2. SAFETY.....	2
2.1 Before Driving.....	2
2.2 Traffic Rules.....	2
2.3 Practice Driving.....	2
2.4 No Passengers.....	3
2.5 No Hauling Heavy Goods.....	3
2.6 Rain.....	3
2.7 While Driving.....	3
2.8 General Warning.....	3
2.9 Railroad Crossing.....	3
2.10 Circumstances to Avoid.....	3
2.11 Mobile Phones and Other Electric Equipment.....	4
2.12 Ramps, Inclines and Drops.....	4
2.13 Maximum User Weight Limit.....	5
2.14 The Leon Series Labeling.....	6
3. EMI/RFI.....	7
3.1 Electromagnetic Interference From Radio Wave Sources.....	7
3.2 The Sources of Radiated EMI Can Be Broadly Classified into Three Types.....	8
3.3 Powered Vehicle Electromagnetic Interference (EMI).....	8
3.4 Warnings.....	9
4. PARTS.....	10
4.1 Leon with Captain Seat.....	10
4.2 Leon with Sling Seat.....	12
4.3 Leon with KISS Seat.....	13
5. OPERATION.....	14
5.1 Controller Cable Tie Location.....	14
5.2 How to Operate Your Wheelchair.....	15
5.3 How to Adjust Your Wheelchair.....	26
6. BATTERIES AND CHARGER.....	62



6.1 Charging the Batteries .....	63
6.2 Charge the Batteries If Any of the Following Conditions Occurs .....	63
6.3 Be Sure to Precisely Follow the Procedures Listed Below. ....	63
6.4 Charger .....	65
6.5 Batteries .....	65
6.6 Cleaning the Batteries.....	66
6.7 Replacing the Batteries.....	67
7. INSPECTION AND MAINTENANCE.....	70
7.1 Daily Check.....	70
7.2 Regular Maintenance Record.....	71
7.3 Tires.....	73
7.4 General Maintenance.....	73
7.5 Suggested Maintenance Procedures .....	74
7.6 Transporting and Storing.....	75
8. OPTIONAL ACCESSORIES.....	76
8.1 Leon Sling Seat.....	76
8.2 Leon Captain Seat .....	76
9. TROUBLESHOOTING .....	77
9.1 VRII Controller, Battery & Diagnostics Indicator.....	77
10. SPECIFICATIONS.....	80
10.1 The Leon Series Static Stability.....	82
11. CLEANING & RECYCLING .....	83
11.1 Cleaning.....	83
11.2 Post-Consumer Recycling .....	84
12. WARRANTY .....	84
12.1 Serial Number.....	84
12.2 Contents of Warranty.....	85
12.3 Warranty Duration and Parts Covered by the Warranty .....	85
12.4 Items Not Covered.....	85
12.5 Problems Not Covered.....	86
12.6 The Responsibilities of the User.....	86
12.7 Warranty Effectiveness.....	87
12.8 Transfer of Warranty Rights .....	87

---

# 1. PREFACE

Please carefully read this owner's manual before using the wheelchair. Improper use of the wheelchair could result in harm, injury or traffic accidents. Therefore, for safe and enjoyable use of the wheelchair, please read this owner's manual.

- 1.1 This owner's manual includes operation instructions for the aspects of the wheelchair, assembly instructions, and instructions on how to deal with possible accidents. This owner's manual is written for Karma powered wheelchair(s): the Leon series (LEN Sling Seat , LEN Captain Seat and LEN KISS seat)
- 1.2 The symbols used in this manual are explained below. Pay special attention to the parts marked with these symbols.

	<b>WARNING</b>	Improper use could lead the user to severe injury or death.
	<b>CAUTION</b>	Improper use could lead the user to severe injury and/or damage to your wheelchair.
	<b>SUGGESTION</b>	Follow these instructions to keep the wheelchair in good condition.

- 1.3 This manual includes the repair and maintenance chart as well as the Warranty. Please keep it in a safe place or with the wheelchair.
- 1.4 If someone else uses the wheelchair, make sure that you give him or her this owner's manual for his or her reference.
- 1.5 As designs change, some illustrations and pictures in this manual may not correspond to the vehicle that you purchased. We reserve the right to make design modifications without further notice.

---

## **2. SAFETY**

### **2.1 Before Driving**

- 2.1.1 The user must be familiar with the use and operation of this wheelchair before driving.
- 2.1.2 Therefore, please always keep these safety guidelines in mind.
- 2.1.3 For a visually impaired people, be sure someone accompanies you in case you need assistance.
- 2.1.4 The occupant shall have sufficient ability, functional capability, visual ability and cognizance to operate the wheelchair safely in its intended environment. If not, do not drive it.
- 2.1.5 Do not let anyone touch the wheels, actuator and armrest when they are in motion or being operated to avoid pinch injury.

### **2.2 Traffic Rules**

- 2.2.1 Pedestrian traffic rules apply to this wheelchair, therefore please follow the rules.
- 2.2.2 Drive only on pedestrian areas such as the sidewalk. Never drive the wheelchair on the highway.
- 2.2.3 Be aware of other vehicles when crossing all roads.
- 2.2.4 Be extremely cautious when driving your wheelchair in heavy traffic or the shopping mall.
- 2.2.5 DO NOT drive your wheelchair when you feel tired or consume alcohol.
- 2.2.6 Please do not drive your wheelchair at night.
- 2.2.7 Please follow pedestrian traffic lights, and comply with the traffic regulation.

### **2.3 Practice Driving**

- 2.3.1 Before you are familiar with the operation of your wheelchair please practice in a wide and open area, like a park. When you drive the wheelchair for the first time, do not set out alone and make sure that you have assistance close by if you need help.
- 2.3.2 To avoid falling off your wheelchair please practice all kinds of driving motions, such as accelerating, stopping, turning, reversing and going

---

up and down ramps.

2.3.3 Please set the speed to medium when you first start practicing.

2.3.4 Be sure you are able to control and operate your wheelchair easily and confidently before you set the speed higher.

## **2.4 No Passengers**

KARMA wheelchair is limited to only one single driver. Do not carry passengers (including children) on your wheelchair.

## **2.5 No Hauling Heavy Goods**

Do not use this wheelchair to carry or haul heavy goods. The maximum weight that can be carried, including goods, is stated beside "Max. User Weight" in Section 10. SPECIFICATIONS.

## **2.6 Rain**

This product is not guaranteed to be water resistant. Please do not drive in the rain, through puddles or spray water to clean this product. (Figure 2.1)

## **2.7 While Driving**

Please carry out daily inspections. Refer to Section 7.1 DAILY CHECK

## **2.8 General Warning**

Do not lean over the side of the wheelchair as such an action may cause you to lose balance and fall.

Be careful not to have your clothing get tangled with the wheels.

## **2.9 Railroad Crossing**

Before crossing the tracks, please stop completely and look both ways.

Cross the tracks perpendicular to avoid your wheels getting stuck.

Do not drive at full speed over railroad tracks.

## **2.10 Circumstances to Avoid**

2.10.1 Avoid roads with heavy traffic, mud, excessive gravel or bumps, snow and ice. These conditions may damage your wheelchair.

2.10.2 Avoid roads that are too narrow or by a canal/waterway without any fence/hedge.

2.10.3 Also avoid places where your wheels might get stuck, slip or not have traction.

---

2.10.4 Do not drive in a gale, at night or in rainy/snowy/foggy/misty weather.

These conditions may cause your wheelchair to rust. (Figure 2.2)

2.10.5 Do not drive in a S curve, do doughnuts or make sudden turns.

2.10.6 Do not take an escalator.

## **2.11 Mobile Phones and Other Electric Equipment**

2.11.1 Do not use a mobile phone or other wireless communication devices while driving. (See Section 3. EMI/RFI)

2.11.2 Do not charge the mobile phone or other electric devices from your wheelchair's batteries.

## **2.12 Ramps, Inclines and Drops**

2.12.1 Do not drive onto a steep ramp. Refer to "Safe Slope" in Section 10. SPECIFICATIONS for your wheelchair's maximum climbing angle

2.12.2 When climbing up to an inclined road, please set the speed higher than the medium speed and drive carefully. (Figure 2.3)

2.12.3 When going down an inclined road, set the speed to "1" and never use reverse.

2.12.4 Do not drive on a road with many bumps and holes close to each other, such as potholes or washboard roads. (Figure 2.4)

2.12.5 Do not make sudden turns when driving on gravel roads or ramps.

2.12.6 The maximum obstacle climbing ability is 6 cm for the Leon series. Exceeding this obstacle height will damage your wheelchair and void your warranty. (Figure 2.5)

2.12.7 When negotiating an obstacle, please slow down. Put your seat into the full upright position and approach it head on (perpendicular).

2.12.8 Just before the obstacle, speed up until the entire wheelchair has conquered the obstacle. Negotiating an obstacle at an angle may cause your wheelchair to tip over. Don't do it!

2.12.9 When climbing down a curb, slow down just before you get to it and only speed up after the entire wheelchair has lowered to the road.

2.12.10 Again, descending obstacles should be done perpendicularly. (Figure 2.6)

2.12.11 Karma does not design wheelchairs to take jumps over or off

---

obstacles. Doing so will void your warranty.



## WARNING

Do not set the wheelchair in freewheel mode when on an incline or decline.

If you breakdown on railroad tracks, first, check for an oncoming train. If a train is coming, get out of its way immediately! If no train is coming, set to freewheel mode and push the wheelchair off the tracks.

### 2.13 Maximum User Weight Limit

2.13.1 Refer to "Max. User Weight" in Section 10. SPECIFICATIONS.

2.13.2 Loading exceeding maximum capacity can damage your wheelchair and cause malfunctions yielding a safety hazard. The warranty does not cover damage caused by improper operation of the wheelchair.



Figure 2-1



Figure 2-2



Figure 2-3



Figure 2-4



Figure 2-5



Figure 2-6

## 2.14 The Leon Series Labeling

Please carefully read all the labeling on the wheelchair before driving it. Do not remove them. Protect them for future reference.

	Labeling	Location
<p>[Circuit Breaker] If this circuit breaker operates, reset it by pushing the button.</p>		
<p>[Finger-Pinch] Avoid it when flip back the armrest.</p>		
		
<p>[Anti-Pinch Warning Label] Be careful when the actuator is active.</p>		
<p>[Wiring Diagram] Do not change the wiring.</p>		
<p>[Freewheel Lever] Follow the label to engage or release it.</p>		
<p>DO NOT TOUCH</p>		
		



### 3. EMI/RFI

This section provides the user with basic information about the problems with EMI, known sources of EMI and protective measures either to reduce the possibility of exposure or to minimize the degree of exposure. This section also shows some conditions in which unexpected or erratic wheelchair movements may occur.



#### CAUTION

**It is very important that you read this information regarding the possible effects of electromagnetic interference on your powered KARMA wheelchair.**

#### 3.1 Electromagnetic Interference From Radio Wave Sources

3.1.1 Powered vehicles may be susceptible to electromagnetic interference (EMI), which is interfering electromagnetic energy (EM) emitted from sources such as radio stations (Radio Frequency Interference), TV stations, amateur radio (HAM) transmitters, two-way radios, and cellular phones. The interference (from radio wave sources) can cause the powered vehicle to release its brakes, move by itself, or move in unintended directions. It can also permanently damage the powered vehicle's control system. The intensity of the interfering EM energy can be measured in volts per meter (V/m). Each powered vehicle can resist EMI up to a certain intensity. This amount of resistance is called its immunity level. The higher the immunity level, the greater the protection. At this time, current technology is capable of achieving at least a 20 V/m immunity level, which would provide useful protection from the more common sources of radiated EMI. This powered vehicle model, with no further modification, has an immunity level of 20 V/m without any accessories.

---

3.1.2 There are a number of sources of relatively intense electromagnetic fields in our everyday environment. Some of these sources are obvious and easy to avoid. Others are not apparent and exposure could be unavoidable. However, we believe that by following the warnings listed below, your risk to EMI can be greatly minimized.

### **3.2 The Sources of Radiated EMI Can Be Broadly Classified into Three Types.**

3.2.1 Hand-held portable transceivers (transmitter-receivers) with the antenna mounted directly on the transmitting unit, such as citizens band (CB) radios, walkie-talkies, security and fire or police transceivers, cellular telephones and other personal communication devices;

**NOTE:**

Some cellular telephones or similar devices transmit signals while they are ON, even though they are not in use.

3.2.2 Medium-range mobile transceivers used in police cars, fire trucks, ambulances and taxis usually having the antenna mounted on the outside of the vehicle; and

3.2.3 Long-range transmitters and transceivers, such as commercial broadcast transmitters (radio and TV broadcast antenna towers) and amateur (HAM) radios.

**NOTE:**

Other types of hand-held devices (cordless phones, laptop computers, AM/FM radios, TV sets, CD players, cassette players, and small appliances such as electric shavers and hair dryers, et cetera) so far as we know, are not likely to cause EMI problems.

### **3.3 Powered Vehicle Electromagnetic Interference (EMI)**

Because EM energy rapidly becomes more intense as one moves closer to the transmitting antenna (source), the EM fields from hand-held radio wave sources (transceivers) are of special concern. It is possible to unintentionally bring high levels of EM energy too close to the powered vehicle's control system while using these devices. This can affect your powered vehicle's

---

movement and braking. Therefore, the warnings listed below are recommended to prevent possible interference with the control system of the powered vehicle.

### 3.4 Warnings

Electromagnetic interference (EMI) from sources such as radio and TV stations, amateur radio (HAM) transmitters, two-way radios and cellular phones can affect powered vehicles and motorized wheelchairs.

Following the warnings listed below should reduce the chance of unintended brake release or powered vehicle movement which could result in serious injury.

3.4.1 Do not operate hand-held transceivers-receivers such as citizens band (CB) radios or turn ON personal communication devices such as cellular phones, while the powered vehicle is turned ON.

3.4.2 Be aware of nearby transmitters, such as radio or TV stations, and try to stay away from them.

3.4.3 If unintended movement or brake release occurs, turn the powered vehicle OFF as soon as it is safe.



#### CAUTION

**Some stores may have automatic (sensor) doors and alarm systems set at certain frequencies that might affect your powered wheelchair.**

3.4.4 Be aware that adding accessories/components or modifying the powered vehicle may make it more susceptible to EMI. There is no easy way to evaluate their effect on the overall immunity of the powered vehicle.

3.4.5 Report all incidents of unintended movement or brake release to your powered vehicle dealer or KARMA, and note whether there was a source of EMI nearby.

## 4. PARTS

### 4.1 Leon with Captain Seat

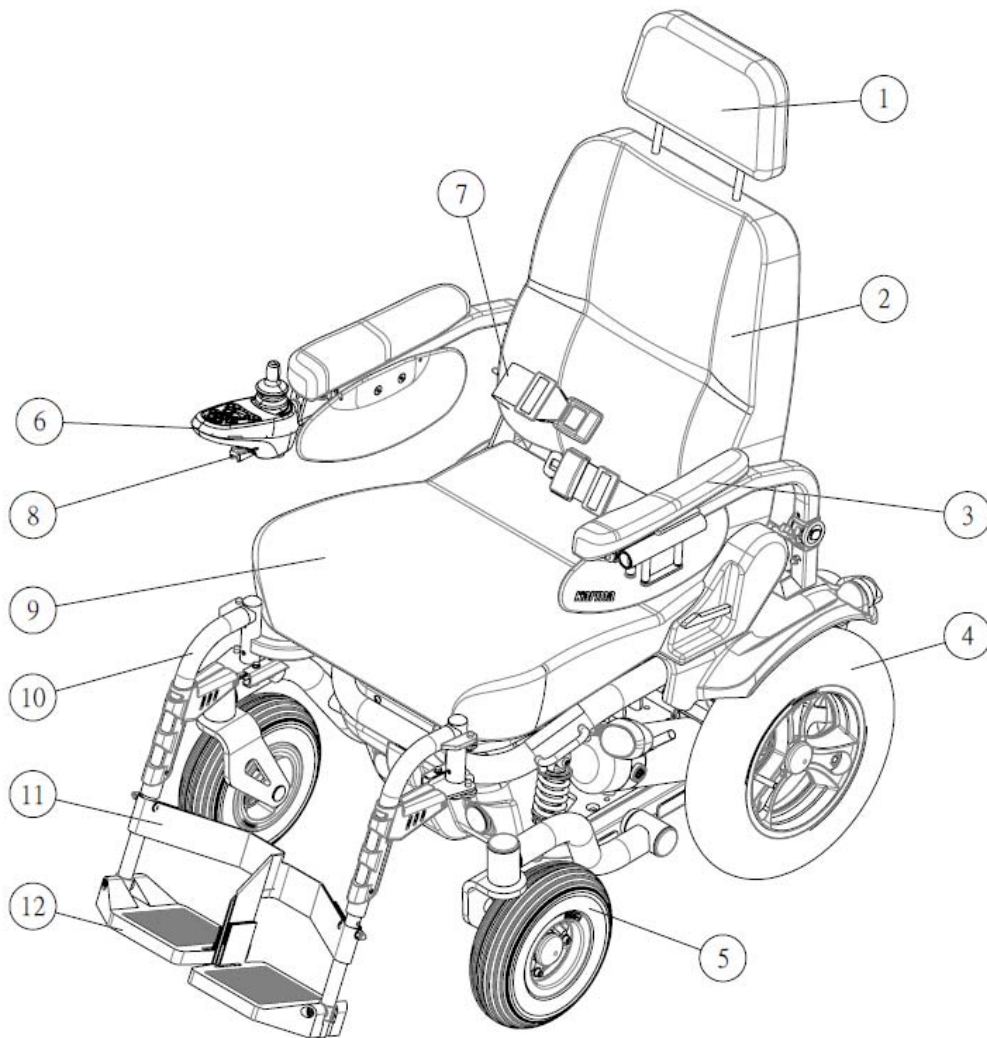

1. Headrest  
2. Captain Seat  
(Backrest)

3. Armrest  
4. Rear Wheel

5. Caster  
6. Controller (Joystick)  
7. Pelvic Belt

8. Charger Socket

9. Captain Seat

10. Footrest  
11. Calf Support  
12. Footplate

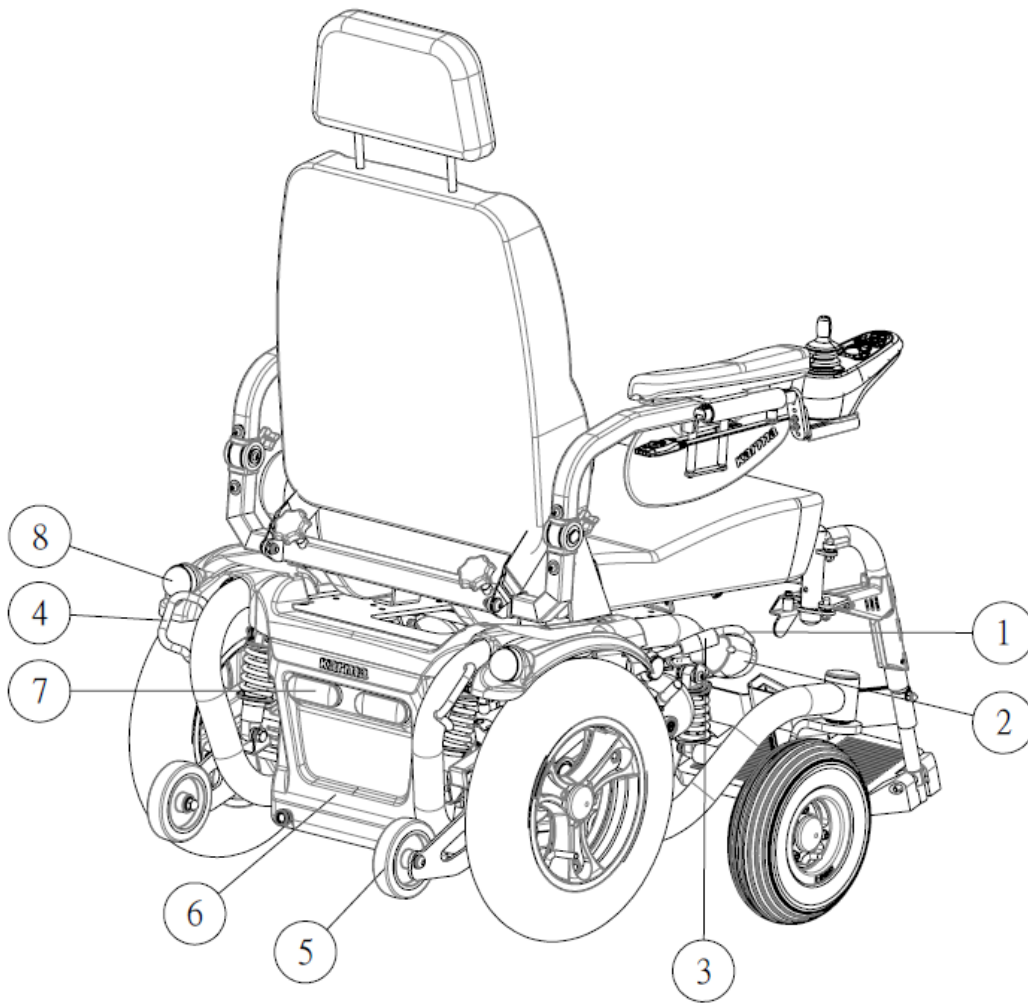

- |                         |                   |                                |
|-------------------------|-------------------|--------------------------------|
| 1. Front Tiedown        | 4. Rear Tiedown   | 7. Tail Light(optional)        |
| 2. Head Light(optional) | 5. Anti-tipper    | 8. Turning<br>Signal(optional) |
| 3. Freewheel Lever      | 6. Battery Casing |                                |



**CAUTION:**

**Standard equipments are subject to change without notice.**

## 4.2 Leon with Sling Seat

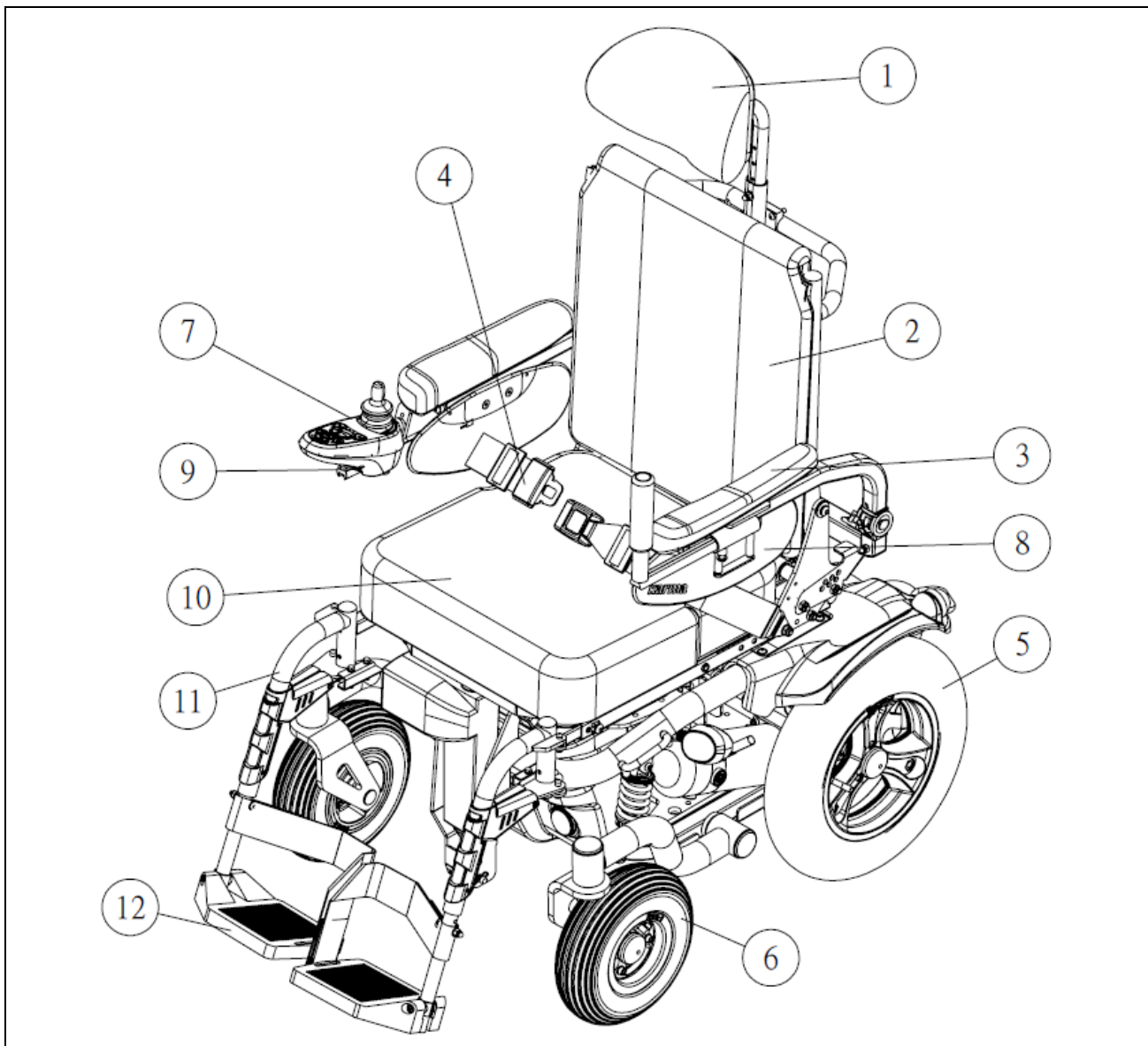

1. Headrest(optional)

2. Sling Seat(Backrest)

3. Armrest

4. Pelvic Belt

5. Rear Wheel

6. Caster

7. Controller(Joystick)

8. Side Panel

9. Charger Socket

10. Sling Seat

11. Footrest

12. Footplate



**CAUTION:**

**Standard equipments are subject to change without notice.**

### 4.3 Leon with KISS Seat

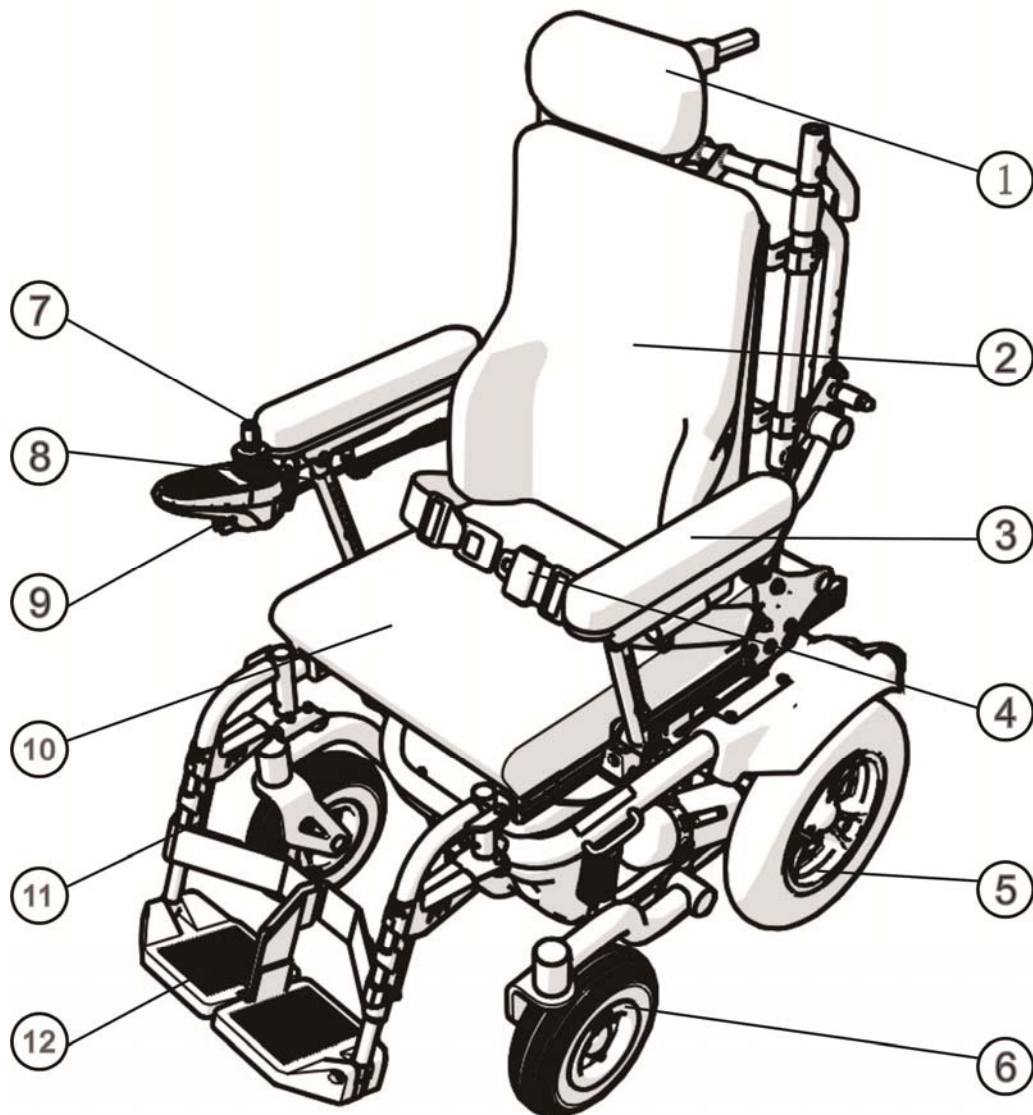

1. Headrest(optional)

2. Backrest

3. Armrest

4. Pelvic Belt

5. Rear Wheel

6. Caster

7. Controller(Joystick)

8. Side Panel

9. Charger Socket

10. Seat

11. Footrest

12. Footplate



**CAUTION:**

Standard equipments are subject to change without notice.

## 5. OPERATION

Except the joystick control panel can be operate by the occupant, other operations should be carried out by an assistant.

Anything wheelchair related that requires tools should be done by your authorized Karma service provider.

### 5.1 Controller Cable Tie Location

5.1.1 The controller for the Leon series is packaged in the carton; after opening the carton, the controller needs to be equipped to the correct position by fastening two screws.

5.1.2 In the case that the controller cable ties becomes loose, please refer to the below figure for the locations to fasten the cable ties, and follow the instructions:

5.1.2.1 At Section A (see the figure below), loosen the cable and leave some of the cable hanging because it facilitates the armrest height adjustment.

5.1.2.2 At Section B (see the figure below), cross the cable tie around the screw. It provides better fixation and keeps the cable tie from sliding out of place.

5.1.2.3 The other areas circled also indicates the cable tie locations.

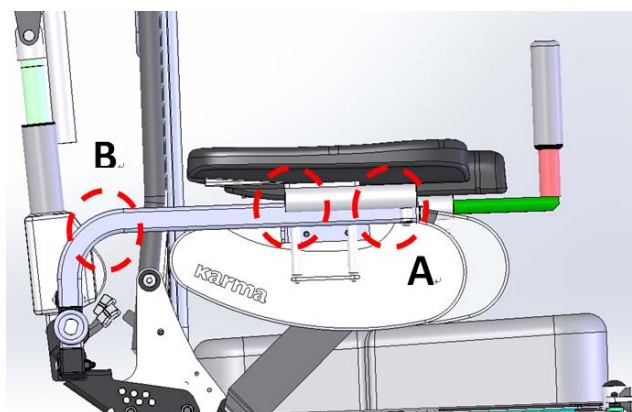

Controller Cable Tie Locations



#### CAUTION:

The controller cable must be fixed as instructed above, otherwise the cable could be damaged and cause malfunction of the wheelchair.

## 5.2 How to Operate Your Wheelchair

### VR2 Controller : Control Panel With Lighting Control

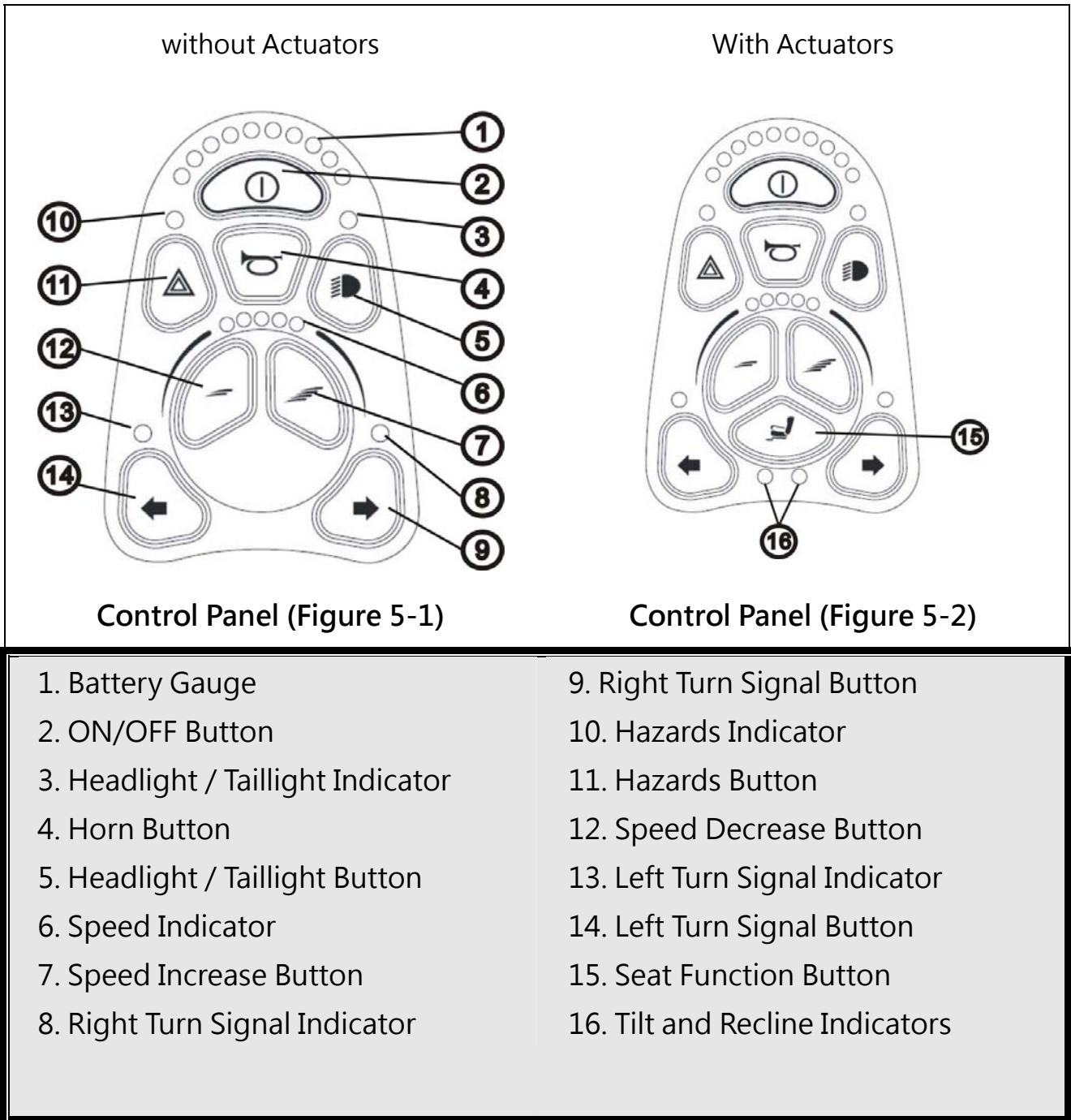

#### 5.2.1 Power ON/OFF

Press the power button. Be sure not to touch the joystick while turning on the controller. Your battery & diagnostics indicator should light up. (See Figure 5-1 and Figure 5.2)

---

## 5.2.2 Locking / Unlocking the Wheelchair

The VR2 control system can be locked to prevent unauthorized use. The locking method is via a sequence of key presses and joystick movements, as detailed below.

### 5.2.2.1 To lock the wheelchair.

5.2.2.1.1 While the control system is switched on, depress and hold the on/off button.

5.2.2.1.2 After one second the control system will beep. Now release the on/off button.

5.2.2.1.3 Deflect the joystick forwards until the control system beeps.

5.2.2.1.4 Deflect the joystick in reverse until the control system beeps.

5.2.2.1.5 Release the joystick, there will be a long beep.

5.2.2.1.6 The wheelchair is now locked.

### 5.2.2.2 To unlock the wheelchair

5.2.2.2.1 Use the on/off button to switch the control system on. The maximum speed / profile indicator will be rippling up and down.

5.2.2.2.2 Deflect the joystick forwards until the control system beeps.

5.2.2.2.3 Deflect the joystick in reverse until the control system beeps.

5.2.2.2.4 Release the joystick, there will be a long beep.

5.2.2.2.5 The wheelchair is now unlocked.

## 5.2.3 Adjusting the Driving Speed

The user can adjust the wheelchair's top speed to suit their preferences and environment. The currently selected top speed is shown on the Speedometer and can be adjusted using the "Increase Speed" and "Decrease Speed" buttons. In the "5 speed" mode pressing the Increase Speed and Decrease Speed buttons steps between one of five top speeds

20% to 100%. In the "fine adjusting" mode pressing and holding the Increase Speed (Decrease Speed) Button ramps the top Speed up (down) in fine steps.

	<b>CAUTION</b>
<p><b>Please slow down before you get used to control your powered wheelchair.</b></p> <p><b>Please slow down your speed when using it indoor.</b></p> <p><b>The controller unit is set to ensure that the chair can give its best performacne. Shoud the setting be adjusted due to medical needs, the adjustment should be made by KARMA dealers. Do not change or adjust the wiring layout of the chair for your safety.</b></p> <p><b>Please slow down your speed when using it indoor.</b></p>	

#### 5.2.4 Driving Speed

You can choose between 1 to 5 orange dots in the speed indicator, with 5 being the maximum speed. Please refer to " Max. Speed " in Section 10.

#### SPECIFICATIONS.

Speed Scale	Speed Equivalencies and Recommended Circumstances
1-2	<ul style="list-style-type: none"> <li>-Speed equivalent to walking slowly on foot</li> <li>-On an decline</li> <li>-Driving indoors or in a narrow space</li> </ul>
3-4	<ul style="list-style-type: none"> <li>-Equivalent to walking at a normal speed</li> <li>-Driving outdoors on flat ground</li> </ul>
5	<ul style="list-style-type: none"> <li>-Speed equivalent to a brisk walk</li> <li>-Driving in an open space</li> <li>-On an incline</li> </ul>

#### 5.2.5 To Stop

Release the joystick and the electromagnetic brake will stop the wheelchair. Make sure that the wheelchair has come to a complete stop before turning the power OFF.



## CAUTION

The stopping distance will vary with your forward/reverse speed. Therefore, please gradually slow down and come to a complete stop well before any obstacles or danger.  
To park the wheelchair, be sure to park on flat ground and then turn the power to OFF.  
**NEVER** use the freewheel mode when going down an incline.  
The electromagnetic brake won't function in freewheel mode.

### 5.2.6 Turn Signal (Indicator Light)

The signal light will flash if you press the right or left signal button.

Turn off the signal light by pressing the button again.

### 5.2.7 Headlights/Taillights

To turn the Headlight/Taillight on, press the Headlight/Taillight Button. Press the Headlight Button again to turn the headlight/taillight off.

### 5.2.8 Warning Signal(Hazards Light)

To turn the Hazards Indicator on, press the Hazards Button. Press the Hazards Button again to turn the hazards function off.



## CAUTION

**Turn off the lights when not in use to save battery power.**

### 5.2.9 Horn Button

The horn will sound for as long as the button is pressed.

### 5.2.10 Battery Gauge

The Battery Gauge is used to indicate power on and provides an estimate of the remaining battery capacity. Any green LEDs lit indicate well-charged batteries. If only amber and red LEDs are lit, the batteries are moderately charged. Recharge before undertaking a long trip. If only red LEDs are lit, the batteries are running out of charge. Recharge as soon as possible.

### 5.2.11 Tilt and Reclining Operation

5.2.11.1 Leon-Captain Seat: Manual Reclining

5.2.11.2 Leon-Sling Seat: Powered Tilt + Powered Reclining

### 5.2.12 Tilt Operation

5.2.12.1 Turn the power on

---

5.2.12.2 Press the Seat Function Button once to toggle the control unit from Drive mode to Seat mode. Powered tilt or recline function will be active as the Tilt Indicators or Recline Indicators are on.

5.2.12.3 Moving the joystick backward to tilt or recline the seat. The maximum tilting angle is 20°.

5.2.12.4 Moving the joystick forward will tilt or recline the seat towards the upright position.

### 5.2.13 Powered Reclining Operation

5.2.13.1 Turn the power on

5.2.13.2 Press the Seat Function Button and move the joystick right. (Moving the joystick left/right while in Seat Mode toggles between Tilting Function and Reclining Function . Pressing the Seat Function Button again puts VR2 back in drive mode. 3 presses are a complete cycle)

5.2.13.3 Move the joystick backward to set the backrest angle. The adjustable range is from 90 to 122 degree.

5.2.13.4 Move the joystick forward tilt the backrest in that direction.

### **R-net control system :**

The R-net control system has two versions of Joystick Module – with and without lighting control. Most of the controls are common to both however, the lighting buttons are only included on the Joystick Module with lighting control. Each of the controls is explained within this section.

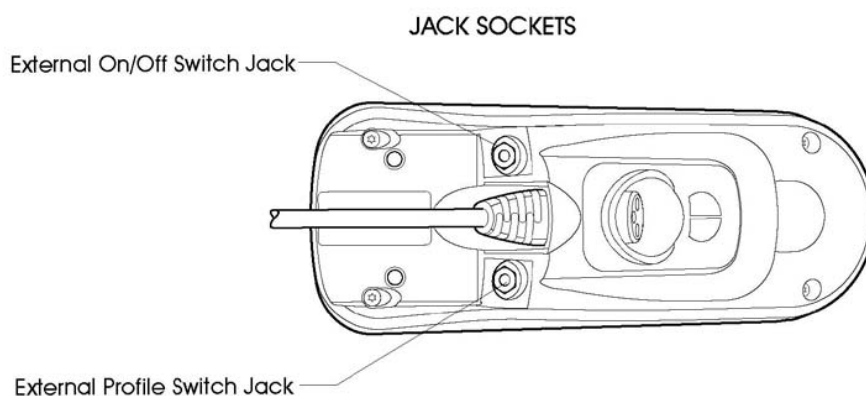
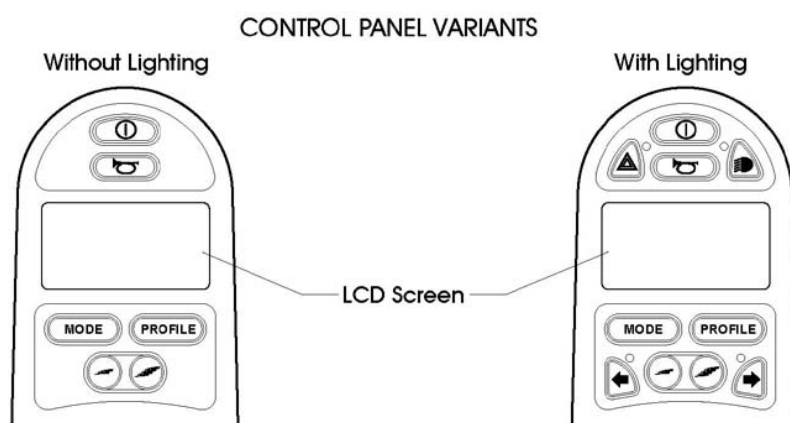
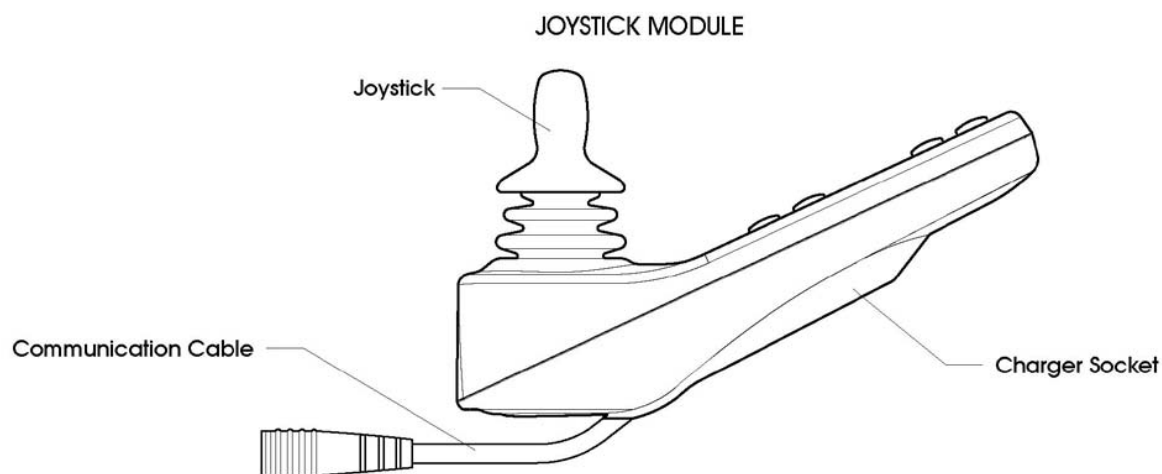

## 5.2.14 Joystick

5.2.14.1 The primary function of the joystick is to control the speed and direction of the wheelchair. The further you push the joystick from the center position the faster the wheelchair will move. When you release the joystick the brakes are automatically applied.

5.2.14.2 If the wheelchair is fitted with actuators, the joystick can also be used to move and select actuators, refer to section 5.5 for more details.

---

## 5.2.15 Buttons

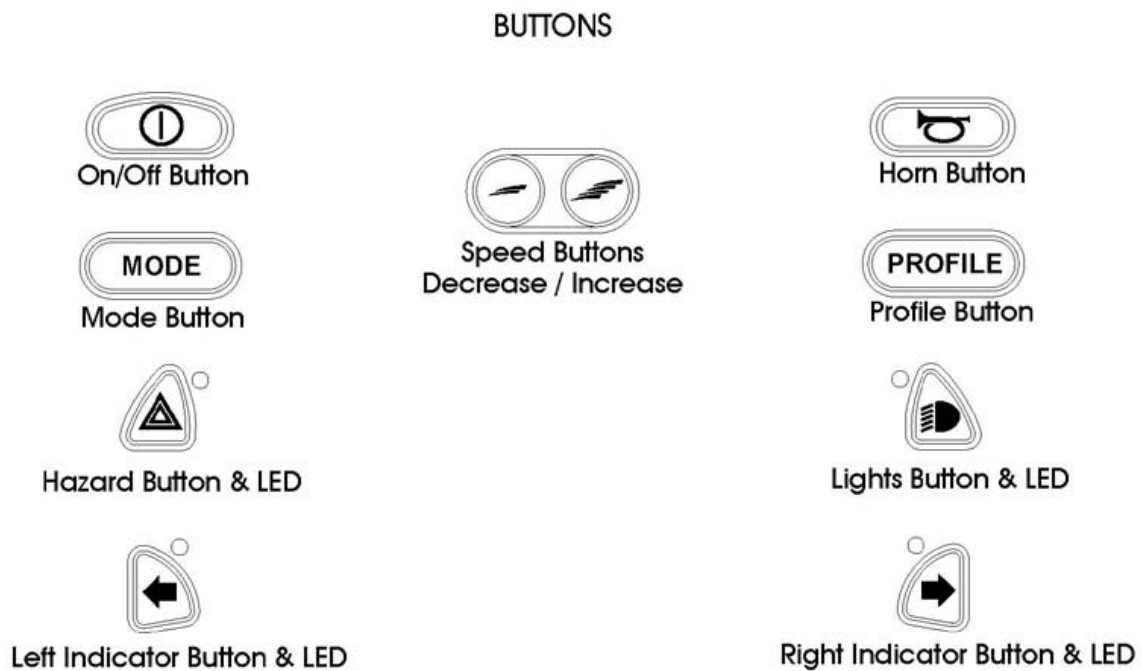

### 5.2.15.1 On/Off Button

The On/Off button applies power to the control system electronics, which in turn supply power to the wheelchair's motors. Do not use the On/Off button to stop the wheelchair unless there is an emergency. (If you do, you may shorten the life of the wheelchair drive components).

### 5.2.15.2 Horn Button

The Horn will sound while this button is depressed.

### 5.2.15.3 Speed Decrease Button

5.2.15.3.1 This button decreases the maximum speed setting.

5.2.15.3.2 Depending on the way the control system has been programmed a momentary screen may be displayed when the button is pressed.

5.2.15.3.3 Refer to section 5 for details of the momentary screen.

5.2.15.3.4 Refer to Chapter - Programming for details.

### 5.2.15.4 Speed Increase Button

5.2.15.4.1 This button increases the maximum speed setting.

5.2.15.4.2 Depending on the way the control system has been programmed a momentary screen may be displayed when the button is pressed.

---

5.2.15.4.3 Refer to section 5 for details of the momentary screen.

5.2.15.4.4 Refer to Chapter - Programming for details.

#### 5.2.15.5 Mode Button

5.2.15.5.1 The Mode button allows the user to navigate through the available operating Modes for the control system. The available modes are dependent on programming and the range of auxiliary output devices connected to the control system.

5.2.15.5.2 Refer to Chapter - Programming for details.

#### 5.2.15.6 Profile Button

5.2.15.6.1 The Profile button allows the user to navigate through the available Profiles for the control system. The number of available Profiles is dependent on how the control system is programmed.

5.2.15.6.2 Depending on the way the control system has been programmed a momentary screen may be displayed when the button is pressed.

5.2.15.6.3 Refer to section 5 for details of the momentary screen.

5.2.15.6.4 Refer to Chapter - Programming for details.

#### 5.2.15.7 Hazard Warning Button and LED

5.2.15.7.1 This button activates and de-activates the wheelchair' s hazard lights. Depress the button to turn the hazards on and depress the button again to turn them off.

5.2.15.7.2 When activated the hazard LED and the indicator LEDs will flash in sync with the wheelchair' s indicators.

#### 5.2.15.8 Lights Button and LED

5.2.15.8.1 This button activates and de-activates the wheelchair's lights. Depress the button to turn the lights on and depress the button again to turn them off.

5.2.15.8.2 When activated the lights LED will illuminate.

#### 5.2.15.9 Left Indicator Button and LED

5.2.15.9.1 This button activates and de-activates the wheelchair' s left

---

indicator. Depress the button to turn the indicator on and depress the button again to turn it off.

5.2.15.9.2 When activated the left indicator LED will flash in sync with the wheelchair' s indicator(s).

#### 5.2.15.10 Right Indicator Button and LED

5.2.15.10.1 This button activates and de-activates the wheelchair' s right indicator. Depress the button to turn the indicator on and depress the button again to turn it off.

5.2.15.10.2 When activated the right indicator LED will flash in sync with the wheelchair' s indicator(s).

#### 5.2.15.11 External On/Off Switch Jack

This allows the user to turn the control system on and off using an external device, such as a buddy button.

#### 5.2.15.12 External Profile Switch Jack

5.2.15.12.1 This allows the user to select Profiles using an external device, such as a buddy button.

5.2.15.12.2 To change the Profile whilst driving simply press the button.

5.2.15.12.3 If the control system is set to latched drive or actuator control operation, then the polarity of the jack input is reversed to effect a fail safe system; meaning this input will provide an External Profile Switch function and an Emergency Stop Switch function.



### CAUTION

**The Joystick Module is supplied with rubber bungs that must be inserted into the Jack Socket when no external device is connected.**

#### 5.2.16 LCD Screen

5.2.16.1 The status of the control system can be understood by observing the LCD screen. The control system is on when the screen is backlit.

5.2.16.2 Refer to section 5 for details on screen symbols.

## 5.2.17 Charger Socket

5.2.17.1 This socket should only be used for charging or locking the wheelchair. Do not connect any type of programming cable into this socket.

5.2.17.2 Refer to section 13 for more details on charging.

5.2.17.3 This socket should not be used as a power supply for any other electrical device. Connection of other electrical devices may damage the control system or affect the E.M.C. performance of the wheelchair.



### CAUTION

The control system's warranty will be voided if any device other than a battery charger supplied, with the wheelchair, or the lock key is connected into this socket.



### WARNING

- Do not put fingers or clothes under the seat or backrest while seat functions are operated.



### WARNING

**DO NOT** tilt the wheelchair on inclines or wet, slippery, icy or oily surfaces. Only tilt the wheelchair on flat surfaces, otherwise it might cause injury to the user.



### CAUTION

The speed will be reduced to half while the seat is tilted at around 7°. The powered wheelchair can not be driven while the seat is tilted over 15°. Do not put fingers or clothes under the seat or backrest while seat functions are operated.



### SUGGESTION

It is recommended that you charge the batteries immediately when the battery indicator shows only three or fewer signals.

After charging or replacing new batteries, drive the wheelchair for 2-3 minutes to make sure the batteries are fully charged before going on a long journey.

In wintertime, the batteries may respond slowly and the drive range may also be reduced. You must store your wheelchair indoors above freezing

temperatures.

When driving on an incline, the battery indicator light might move up and down. This is normal.

Even if the batteries are used properly their capacity will decay over time, thereby reducing the drive range (maximum distance traveled per full charge). Thus, when the drive range becomes about 50% of what brand new batteries would offer, it's time to replace them with new batteries. Otherwise, the batteries may die unexpectedly leaving you in a possibly precarious situation.

The drive range will be shortened when driving frequently on slopes or uneven ground or over curb, as this consumes more battery power.

### 5.2.18 Freewheel Lever

The Leon series is supplied with a freewheel lever device to allow manual pushing of the powered wheelchair if required. The freewheel lever is at the axle of the rear wheels.

5.2.18.1 Freewheel Mode: Turn the lever up to the upmost position. The wheelchair will now roll freely. ( Figure 5.2.18-1)

5.2.18.2 Drive Mode: Turn the lever downwards to the lowest position. The wheelchair can be driven by motor power. Ensure the lever is at the drive mode position.( Figure 5.2.18-2)



Figure 5.2.18.1



Figure 5.2.18-2



### CAUTION

Always ensure that the wheelchair is in Drive Mode before using the wheelchair. (i.e. Before turning on the controller). When the wheelchair is in Freewheel Mode, make sure that there's an attendant that can offer assistance.

### 5.2.19 Tires

The rear wheels and the casters are pneumatic tires. Please refer to the tires pressure specified on the tire walls to maintain the tires at

---

the correct pressure. Do not let anyone touch the wheels when the wheelchair is in motion to avoid pinch injury.

### 5.3 How to Adjust Your Wheelchair



#### CAUTION

**When adjusting the footrest or the footplates, the user's legs should be supported or kept safe from possible injury.**

5.3.1 Footrest : The Leon series can be mounted with several types of KARMA footrests.

#### 5.3.1.1 Swing-Away and Detach Footrest

To swing away and detach the footrests, pull the swing-away lever (Figure 5.3.1-1), then you can swing away and/or detach the footrests. (Figure 5.3.1-2) It can make transferring in and out of the wheelchair easier.



Figure 5.3.1-1



Figure 5.3.1-2



Figure 5.3.1-3



Figure 5.3.1-4

#### 5.3.1.2 Vertical Swing-away Footrest

To swing away and detach the footrests, pull the swing-away lever (Figure 5.3.1-3), then you can swing away and/or detach the footrests. (Figure 5.3.1-4) It can make transferring in and out of the wheelchair easier.

#### 5.3.1.3 Stump Footrest

5.3.1.3.1 Stump footrest is shown as Figure 5.3.1-5

5.3.1.3.2 To swing away and detach the footrests, pull the swing-away lever (Figure 5.3.1-6), then you can swing away and/or detach the footrests. (Figure 5.3.1-7) It can make transferring in and out of the wheelchair easier.

5.3.1.3.3 Use the #13 box end Wrench to loosen the bolt on the top of

---

L-shape tube.(Figure 5.3.1-8) Adjust the footrest height and re-tighten the bolt.

#### 5.3.1.3.4 Footrest adjustment in Longitudinal (Fore/Aft) Position :

Use the #4 Allen Key Wrench and the #10 box end Wrench to make this adjustment. Remove the screws then adjust the footrest to accommodate the user's leg position and flexibility (Figure 5.3.1-9). Re-tighten the screws.

#### 5.3.1.3.5 Footrest adjustment in left or right Position :

Use the #10 box end Wrench to make this adjustment. Loosen the screws then adjust the footrest to accommodate the user's leg position and flexibility (Figure 5.3.1-10). Re-tighten the screws.

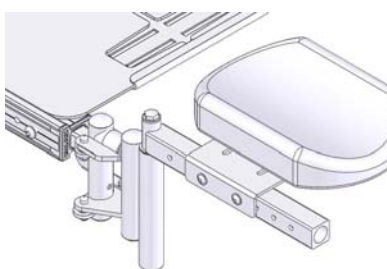

Figure 5.3.1-5

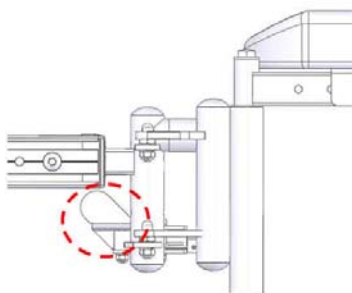

Figure 5.3.1-6

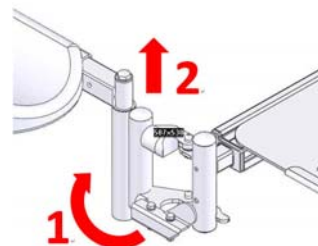

Figure 5.1.3-7

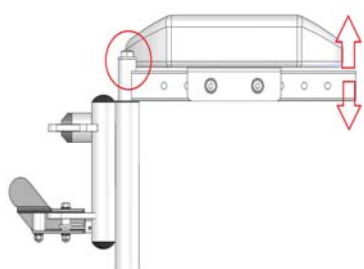

Figure 5.3.1-8

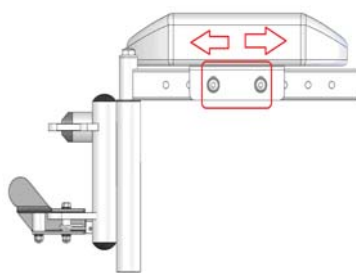

Figure 5.3.1-9

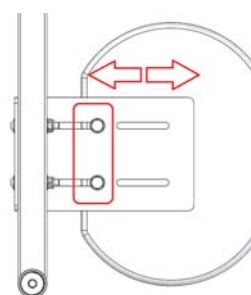

Figure 5.3.1-10

#### 5.3.1.4 Elevating & Swing away Footrest

5.3.1.4.1 Elevating & Swing away Footrest is shown as Figure 5.3.1-11.

5.3.1.4.2 To swing away and detach the footrests, pull the swing-away lever (Figure 5.3.1-12), then you can swing away and/or detach the footrests. (Figure 5.3.1-13) It can make transferring in and out of the wheelchair easier.

---

### 5.3.1.4.3 Footrest angle adjustment :

Raise the footrest to an appropriate angle to accommodate the user's leg position and flexibility. (Figure 5.3.1-14)

Before descending the footrest, be sure to hold it and prevent it from dropping suddenly. Press the release lever and lower the footrest. (Figure 5.3.1-15)

### 5.3.1.4.4 Calf support adjustment :

Use the #3 Allen Key Wrench to remove the screws behind the calf support. Adjust the calf support to accommodate the user's leg position and flexibility. (Figure 5.3.1-16) Re-tighten the screws.

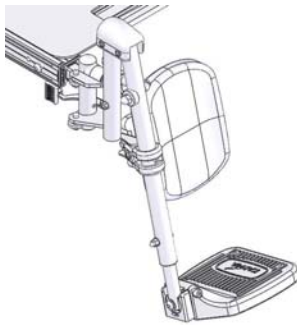

Figure 5.3.1-11

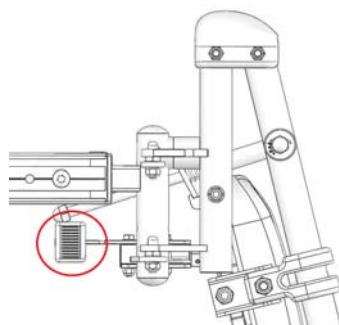

Figure 5.3.1-12

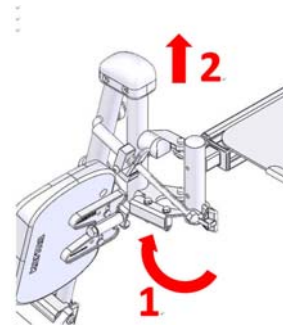

Figure 5.1.3-13

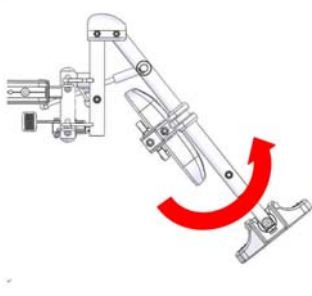

Figure 5.1.3-14

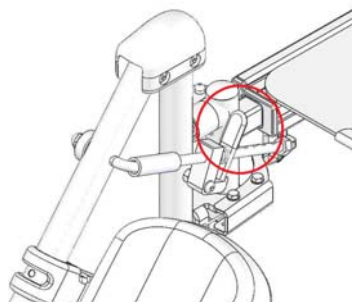

Figure 5.1.3-15

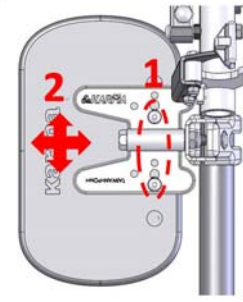

Figure 5.1.3-16

### 5.3.1.5 Powered Elevating & Swing away Footrest

5.3.1.5.1 Powered Elevating & Swing away Footrest is shown as Figure 5.1.3-17.

5.3.1.5.2 To swing away and detach the footrests, pull the swing-away lever (Figure 5.1.3-18), then you can swing away and/or detach the footrests. (Figure 5.1.3-19) It can make transferring in and out of the wheelchair easier.

### 5.3.1.5.3 Calf support adjustment :

- Use the #5 Allen Key Wrench to loosen the screw and adjust the calf support to accommodate the user's leg position and flexibility. (Figure 5.1.3-20) Re-tighten the screws.
- Use the #6 Allen Key Wrench to remove the screw and adjust the calf support forwards or backwards. (Figure 5.1.3-21) Re-tighten the screws.
- Use the #3 Allen Key Wrench to remove the screws behind the calf support and adjust the calf support up, down, left or right. (Figure 5.1.3-22) Re-tighten the screws.

### 5.3.1.5.4 Select footrest adjustment form the controller screen.

(Figure 5.1.3-23) Raise or lower the footrest to an appropriate angle by operating the joystick. (Figure 5.1.3-24, Figure 5.1.3-25)

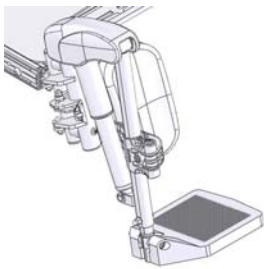

Figure 5.1.3-17

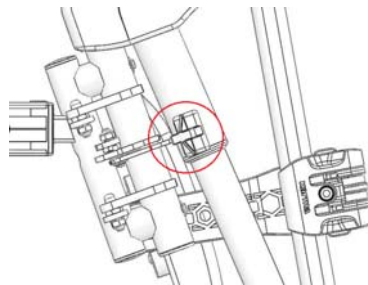

Figure 5.3.1-18

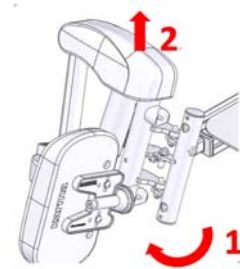

Figure 5.1.3-19

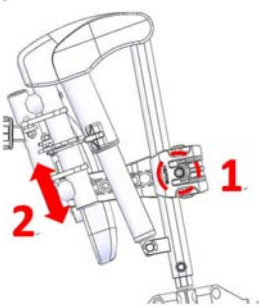

Figure 5.1.3-20

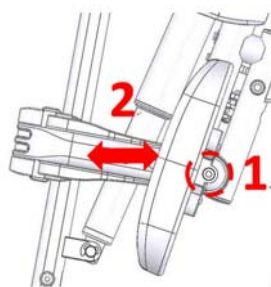

Figure 5.3.1-21

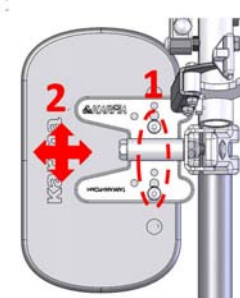

Figure 5.3.1-22



Figure 5.3.1-23

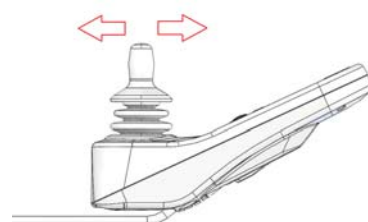

Figure 53.1-24

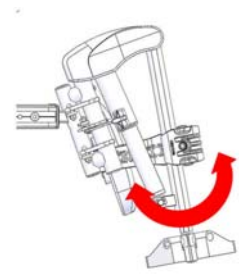

Figure 5.3.1-25

---

## 5.3.2 Footrest Adjustment in Longitudinal (Fore/Aft) Position

### 5.3.2.1 Sling seat and Captain seat :

Please use the #4 Allen Key Wrench included in your KARMA Tool Kit to make this adjustment. Remove the screws under the seat (Figure 5.3.2-1) then adjust the footrest to accommodate the user's leg position and flexibility (Figure 5.3.2-2). Re-tighten the screws.



Figure 5.3.2-1



Figure 5.3.2-2

### 5.3.2.2 KISS seat :

5.3.2.2.1 Please use the #5 Allen Key Wrench to make this adjustment.

Remove the screws under the seat (Figure 5.3.2-3) then adjust the footrest to accommodate the user's leg position and flexibility (Figure 5.3.2-4). Re-tighten the screws.

5.3.2.2.2 The procedures to adjust the powered footrest are the same as those described on 5.3.2.2.1. Make sure the cable is properly routed and fastened after adjusting the footrest. (Figure 5.3.2-5)



Figure 5.3.2-3

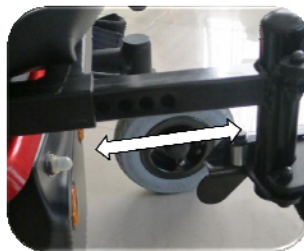

Figure 5.3.2-4



Figure 5.3.2-5

## 5.3.3 Footplates Adjustment

The footplate length should be adjusted according to the user's calf length. Go to your service provider for adjustment or follow below instructions:

### 5.3.3.1 Standard Footplate

---

Use the #13 box end Wrench to loosen the bolt at the side of the footplate. Adjust the footplate height and re-tighten the bolt. (Figure 5.3.3-1)



Figure 5.3.3-1

### 5.3.3.2 Tube-in-center Footplate

Use the #4 Allen Key Wrench and the #10 box end Wrench to loosen the bolt. (Figure 5.3.3-2) Adjust the footplate height and re-tighten the bolt. (Figure 5.3.3-3, Figure 5.3.3-4)



Figure 5.3.3-2



Figure 5.3.3-3



Figure 5.3.3-4



### 5.3.3.3 Angle and Depth Adjustable Footrest

5.3.3.3.1 Use the #4 Allen Key Wrench and the #10 box end Wrench to loosen the bolt. (Figure 5.3.3-2) Adjust the footplate height and re-tighten the bolt. (Figure 5.3.3-3), Figure 5.3.3-4)

5.3.3.3.2 Use the #4 Allen Key Wrench to loosen the screws. (Figure 5.3.3-5) Adjust the footplate left, right, forwards or backwards. Re-tighten the bolt. (Figure 5.3.3-6)

5.3.3.3.3 Use the #17 box end Wrench to loosen nut A. After adjusting the footplate angle, tighten screw B and nut A. (Figure 5.3.3-7)



Figure 5.3.3-5

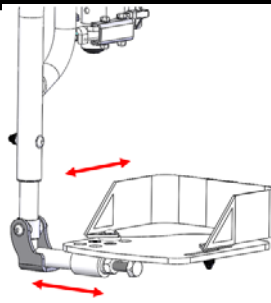

Figure 5.3.3-6

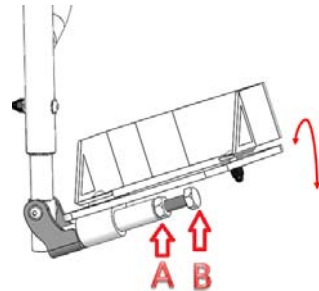

Figure 5.3.3-7

#### 5.3.3.4 Angle Adjustable Footplate

5.3.3.4.1 Angle Adjustable Footplate is shown as Figure 5.3.3-8

5.3.3.4.2 Use the #4 Allen Key Wrench and the #10 box end Wrench to loosen the bolt. (Figure 5.3.3-9) Adjust the footplate height and re-tighten the bolt.

5.3.3.4.3 Use the #5 Allen Key Wrench to loosen the screw. After adjusting the footplate angle, re-tighten it. (Figure 5.3.3-10)

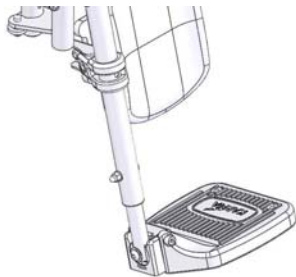

Figure 5.3.3-8



Figure 5.3.3-9

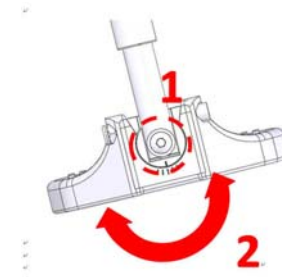

Figure 5.3.3-10

#### 5.3.4 Center Mount Legrest Assembly

5.3.4.1 When adjusting the footplate upwards or downwards for the needs of the user, use the #6 Allen Key Wrench to loosen the bolt. (Figure 5.3.4-1) After adjusting the footplate, re-tighten the bolt.

5.3.4.2 When adjusting the footplate inwards or outwards for the needs of the user, use the #17 box end Wrench to loosen the nut. (Figure 5.3.4-2) and use the #5 Allen Key Wrench to adjust the bolt. Flip the footplate over to check whether it is located at appropriate angle. The adjustable range is between 0° and 15°. After adjusting the footplate, re-tighten the nut.

5.3.4.3 When adjusting the whole footplate assembly angle for the needs of the user, use the #5 Allen Key Wrench to loosen the bolts on both sides. (Figure 5.3.4-3) The adjustable angle is -5°, 0°, 5°, 10° and 15°. Ensure the footplate assembly does not interfere with other parts. The adjustable angle also depends upon the type of the seat.

#### 5.3.4.4 Adjusting the Calf Pad

5.3.5.4.1 When adjusting the calf pad upwards, downwards, forwards or backwards, use the #5 Allen Key Wrench to loosen the four bolts on both sides. (Figure 5.3.4-4) After adjusting the calf pad to the appropriate position, re-tighten the bolts.

5.3.4.4.2 When adjusting the calf pad leftwards or rightwards, use the #4 Allen Key Wrench to loosen the bolts. (Figure 5.3.4-5) After adjusting the calf pad to the appropriate position, re-tighten the bolts.



### CAUTION

**When adjusting the footrest or footplate, ensure the user's feet are appropriately supported.**

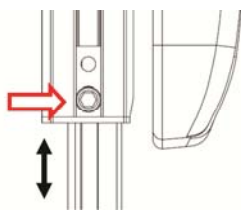

Figure 5.3.4-1

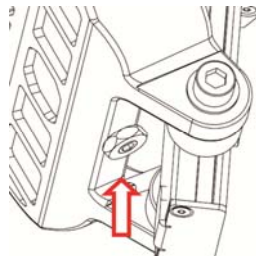

Figure 5.3.4-2

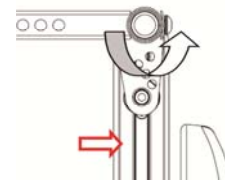

Figure 5.3.4-3

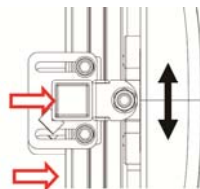

Figure 5.3.4-4

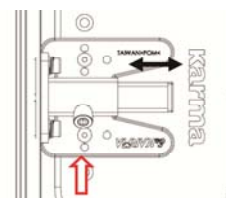

Figure 5.3.4-5

#### 5.3.5 Armrest Height Adjustment

##### 5.3.5.1 Leon with Sling Seat

In order to position the user's arms and shoulders correctly, the armrests are adjustable in height by 7 cm from 18 cm above the seat rail to 25 cm.

---

Use the #5 Allen Key Wrench from KARMA Tool Kit to loosen the height adjustment bolts under the armrest pad (Figure 5.3.5-1). Adjust the armrest to the proper height. Finally, re-tighten the bolts. (Figure 5.3.5-2)

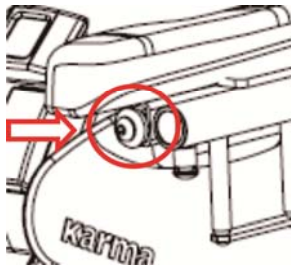

Figure 5.3.5-1

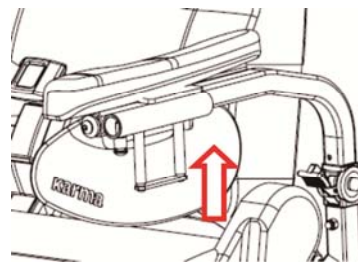

Figure 5.3.5-2

### 5.3.5.2 Leon with KISS seat

#### Detachable T-Armrest Set Adjustment

5.3.5.2.1 Detachable T-Armrest set is shown as Figure 5.3.5-3.

5.3.5.2.2 The whole armrest assembly can be removed by releasing lever A. (Figure 5.3.5-4)

5.3.5.2.3 Use the #4 Allen Key Wrench to loosen the screws. Adjust the armrest forwards or backwards. Re-tighten the screws. (Figure 5.3.5-5)

5.3.5.2.4 By releasing lever B, the height of the armrest can be adjusted and the armrest pad assembly can be removed. (Figure 5.3.5-6)

5.3.5.2.5 Use the #3 Allen Key Wrench to loosen the screws under the armrest pad. Adjust the armrest pad forwards or backwards. Re-tighten the screws. (Figure 5.3.5-7)

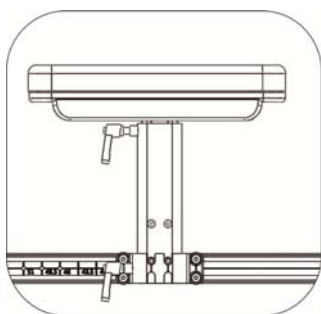

Figure 5.3.5-3

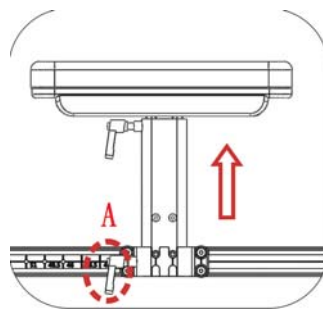

Figure 5.3.5-4

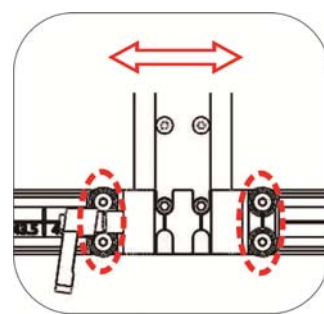

Figure 5.3.5-5

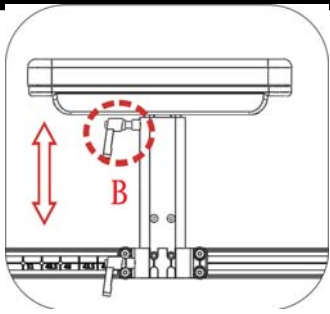

Figure 5.3.5-6

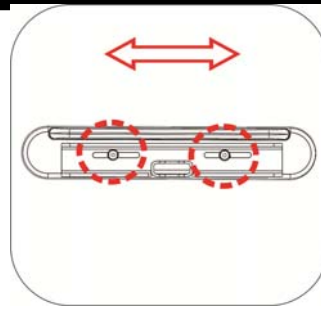

Figure 5.3.5-7

### 5.3.6 Flip Back Armrest Assembly

5.3.6.1 The flip Back armrest assembly of KISS seat is shown as Figure 5.3.6-1

5.3.6.2 Press the spring button and flip the armrest back. (Figure 5.3.6-1)

5.3.6.3 When adjusting the whole armrest assembly upwards or downwards, use the #4 Allen Key Wrench and the #10 box end Wrench to loosen the screw used to fixing the armrest bracket. (Figure 5.3.6-2)

5.3.6.4 When adjusting the armrest pad upwards or downwards, use the #4 Allen Key Wrench to loosen the screw used to fixing the armrest frame. (Figure 5.3.6-3)

5.3.6.5 When adjusting the whole armrest pad assembly forwards or backwards, use the #4 Allen Key Wrench to loosen the screw used to fixing the armrest adjustable frame. The total range of adjustment is 5cm ,in increments of 2.5 cm. (Figure 5.3.6-4)

5.3.6.6 When adjusting the armrest pad forwards or backwards, use the #3 Allen Key Wrench to loosen the screw used to fixing the armrest pad. The total range of adjustment is 5cm ,in increments of 2.5 cm. (Figure 5.3.6-5)

5.3.6.7 In order to keep the armrest pad horizontal, the flip back armrest assembly might need to be adjusted together with the backrest angle according to table 6-1 and table 6-2. (Figure 5.3.6-7) When adjusting the angle of the flip back armrest, use the #4 Allen Key Wrench to loosen the screws used to fixing the adjustable plate. (Figure 5.3.6-6)

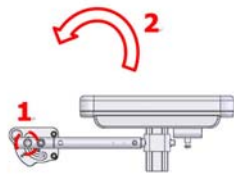

Figure 5.3.6-1

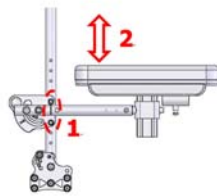

Figure 5.3.6-2

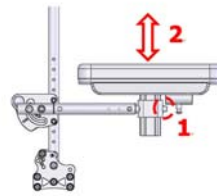

Figure 5.3.6-3

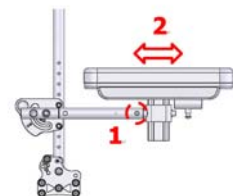

Figure 5.3.6-4

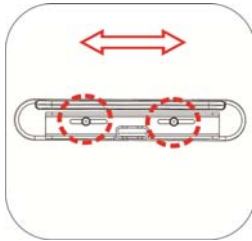

Figure 5.3.6-5

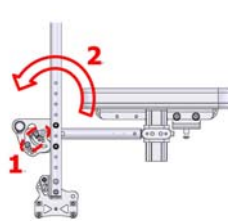

Figure 5.3.6-6



Figure 5.3.6-7

	Armrest angle.	1.	2.
		0 度	C、G
	5 度	D、H	4、11
	10 度	E、G	5、8
	15 度	F、H	6、12
	20 度	A、G	1、9
	25 度	B、H	2、13
	30 度	C、G	4、10

Table 6-1 Armrest angle adjustment table

	Back pad angle.	1.	2.
		0 度	B
	5 度	C	5
	10 度	A	1
	15 度	B	3
	20 度	D	7
	25 度	C	6
	30 度	B	4

Table 6-2 Back pad angle adjustment table

### 5.3.7 Flip-Back Reclining Armrest

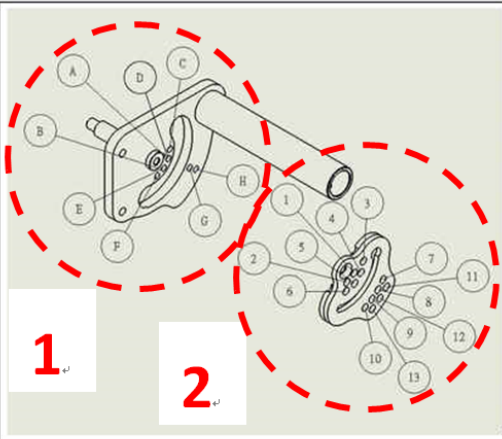
5.3.7.1 Flip-Back reclining armrest is shown as Figure 5.3.7-1

5.3.7.2 By pulling the lock pin and turning it in 90 degree, the armrest can be lifted backwards. (Figure 5.3.7-2)

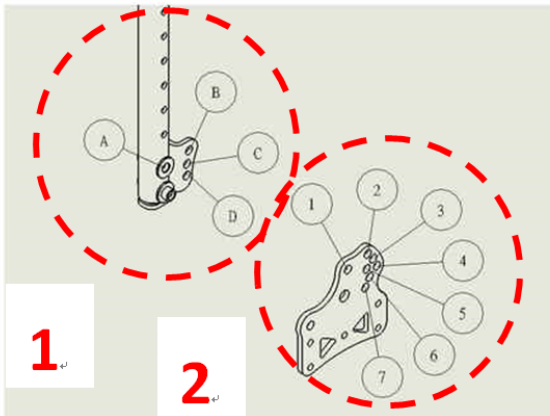
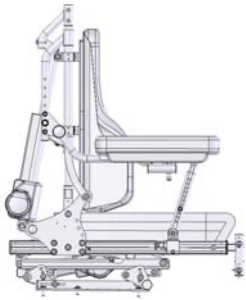

Figure 5.3.7-1

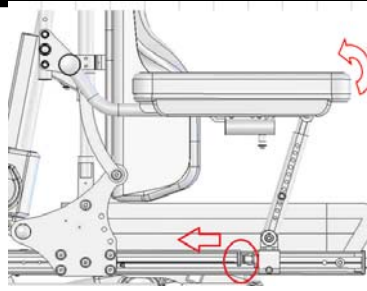

Figure 5.3.7-2

5.3.7.3 When putting the armrest back to the working position, be sure part A is properly inserted into part B. Turn the lock pin in 90 degree and make sure the armrest is properly installed. (Figure 5.3.7-3)

5.3.7.4 Use the #4 Allen Key Wrench and the #10 box end Wrench to remove the screws. Adjust the armrest height and re-tighten the screws. (Figure 5.3.7-4)

5.3.7.5 Use the #5 Allen Key Wrench to loosen the screw. Adjust the base block forwards or backwards and re-tighten the screw. (Figure 5.3.7-5)

5.3.7.6 Use the #4 Allen Key Wrench and the #10 box end Wrench to remove the screws and nuts. Adjust the armrest to accommodate the user's arm position and flexibility (Figure 5.3.7-6). Re-tighten the screws.

5.3.7.7 Use the #3 Allen Key Wrench to loosen the screws. Adjust the armrest pad forwards or backwards and re-tighten the screw. (Figure 5.3.7-7)

5.3.7.8 Recline the seat by operating the joystick after completing all of the adjustments. Be sure the movement of armrest is proper and smooth.

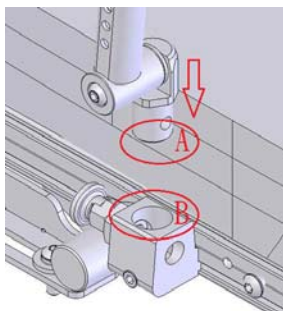

Figure 5.3.7-3

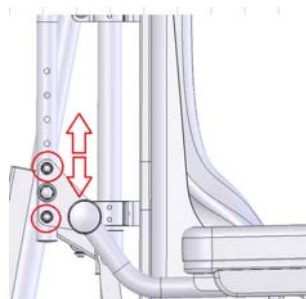

Figure 5.3.7-4

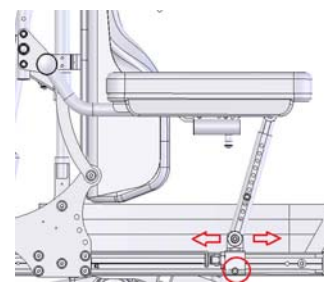

Figure 5.3.7-5

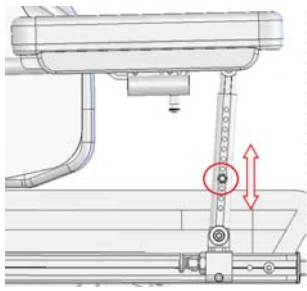

Figure 5.3.7-6

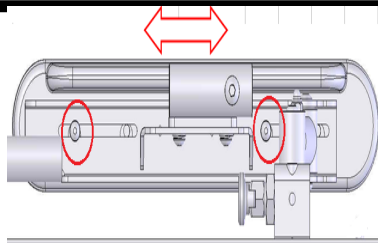

Figure 5.3.7-7

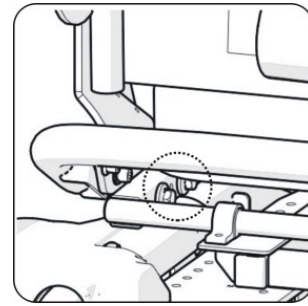

Figure 5.3.8-1

### 5.3.8 Seat Depth and Seat Width Adjustment

#### **Leon with Sling Seat (Seat Depth Adjustment)**

5.3.8.1 Use the #13 box end Wrench from KARMA Tool Kit to loosen the two bolts under the seat . Remove the bolts on the other side. (Figure 5.3.8-1).

5.3.8.2 There are two evenly spaced holes for incremental adjustments which is in increments of 25.4 mm(1" ). The total range of adjustment is 50 mm. (Figure 5.3.8-2).

5.3.8.3. Move the seat forward or backward to the desired position.

5.3.8.4 Re-tighten the bolts.

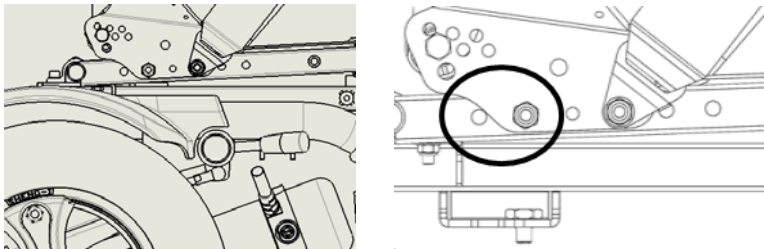

Figure 5.3.8-2

#### **Leon with KISS Seat (Seat Depth Adjustment)**

5.3.8.5 The KISS seat is shown as Figure 5.3.8-3.

5.3.8.6 Use the #4 Allen Key Wrench to loosen the screws A and remove the screw B on both sides of the backsupport frame. Adjust the base plate forwards or backwards to accommodate the user's needs. (Figure 5.3.8-4). Re-tighten the screws.

5.3.8.7 The rails for adjusting the seat depth can be divided into two types, one for adults and the other for children.(Figure 5.3.8-5). The

adjustable range is shown as below.

Adults : 41 · 43.5 · 46 · 48.5 · 51 (cm)

Children : 31 · 33.5 · 36 · 38.5 · 41 (cm)

5.3.8.8 Use the #4 Allen Key Wrench to loosen the screws behind the backsupport . Adjust the backsupport forwards, backwards or at an angle to accommodate the user's needs. (Figure 5.3.8-6). Re-tighten the screws.



### CAUTION

Adjusting the seat depth will change the center-of-gravity position. For your safety, contact your KARMA wheelchair dealer for adjustment.

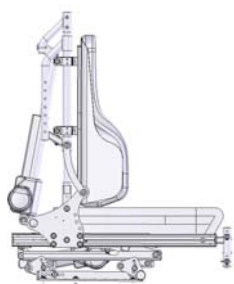

Figure 5.3.8-3

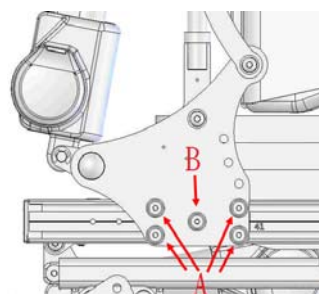

Figure 5.3.8-4

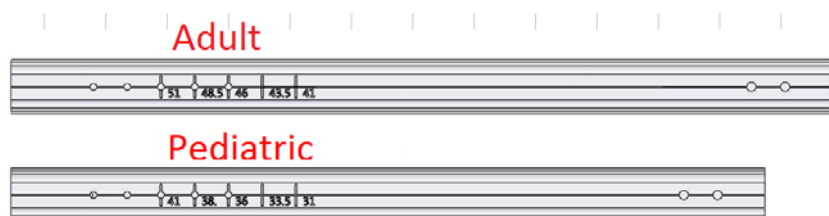

Figure 5.3.8-5

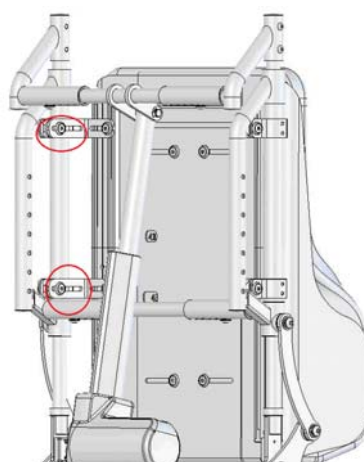

Figure 5.3.8-6

---

## Leon with KISS Seat (Seat Width Adjustment)

### KISS Seat without Tilt and Recline Options

5.3.8.9 KISS Seat without tilt and recline options is shown as Figure 5.3.8-7.

5.3.8.10 Use the #4 Allen Key Wrench to remove the screws A and the plate B. (Figure 5.3.8-8)

5.3.8.11 Use the #4 Allen Key Wrench to loosen the screws C. (Figure 5.3.8-9)

5.3.8.12 Use the #5 Allen Key Wrench to remove the screws D. Move part E and F inwards or outwards to adjust the seat width in order to meet user's needs. Re-tighten all screws. (Figure 5.3.8-10)

5.3.8.13 When adjusting the backsupport width, be sure the number H in the window matches with the seat width and both edges of the plate is in line with the marks G. (Figure 5.3.8-11) Re-tighten the screws C and the torque is set at 10N/m or 88in/lb . (Figure 5.3.8-12)

5.3.8.13 The adjustable ranges can be divided into two groups, one for adults and the other for children. (Figure 5.3.8-12, Figure 5.3.8-13)

5.3.8.14 Adults : 41 · 43.5 · 46 · 48.5 · 51 (cm)

5.3.8.15 Children : 31 · 33.5 · 36 · 38.5 · 41 (cm)

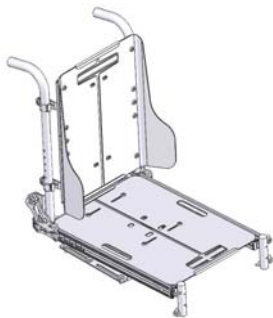

Figure 5.3.8-7

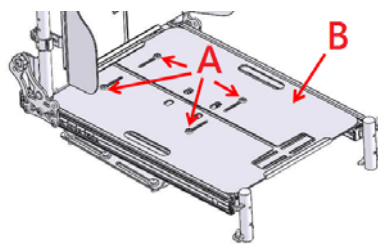

Figure 5.3.8-8

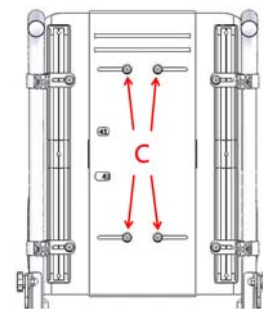

Figure 5.3.8-9

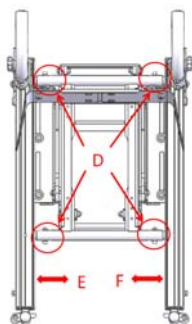

Figure 5.3.8-10

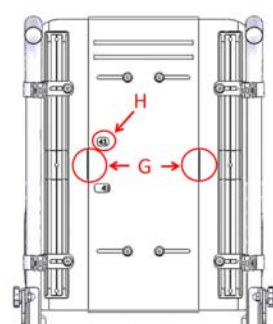

Figure 5.3.8-11

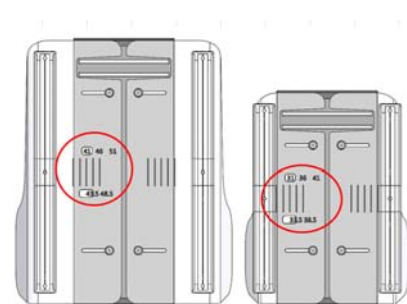

Figure 5.3.8-12

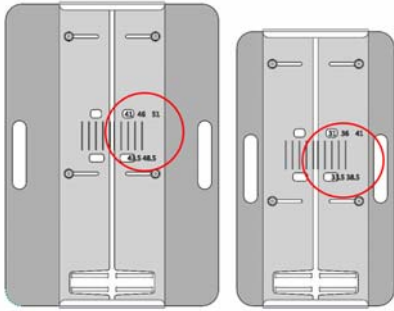

Figure 5.3.8-13

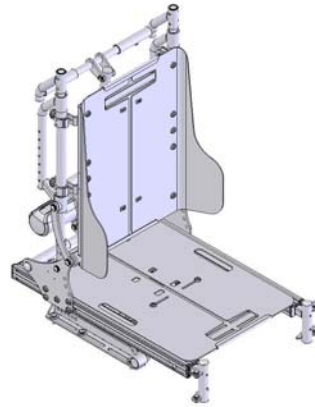

Figure 5.3.8-14

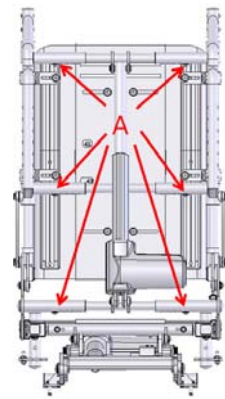

Figure 5.3.8-15

### KISS Seat with Reclining Option

5.3.8.10 KISS Seat with recline option is shown as Figure 5.3.8-14.

5.3.8.10.1 The procedures to adjust the the seat width are almost the same as those of KISS seat without tilting and reclining options except step 5.3.8.11. Befoe adjusting the backsupport width, remove the screws A. (Figure 5.3.8-15)

### 5.3.9 Seat Angle Adjustment

Leon Sling Seat with Tilting Function :

The initial seat angle is set at 2°. If the desired seat angle can be 5°, pull out the hair pin cotter and E Ring from the lower hole (Figure 5.3.9-1) and insert them in the upper hole.

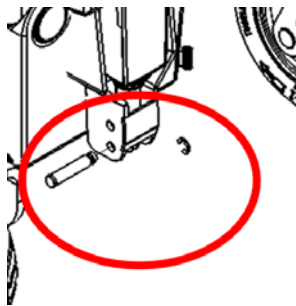

Figure 5.3.9-1

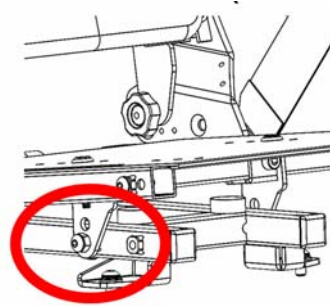

Figure 5.3.9-2

Leon Sling Seat without Tilting Option :

The initial seat angle is set at 2°. If the desired seat angle can be 5°, Lossen the screws at both the left side and right side from the lower hole (Figure 5.3.9-2) and insert them in the upper hole.

Leon KISS Seat with Tilting Option (Including seat height adjustment) :

5.3.9.1 KISS Seat with Tilting option is shown as Figure 5.3.9-3.

5.3.9.2 Depending on the user's needs, check table 5-1 to see whether it is

---

necessary to adjust the plates I, II, III, IV and V. (Figure 5.3.9-4, Figure 5.3.9-8)

5.3.9.3 If it necessary to adjust the adjustable seat height plate, carry out the following steps.

- \* Use the #5 Allen Key Wrench to remove the screws from F3, C and P4 on both sides of the seat base. Remove Plate IV. (Figure 5.3.9-4)
- \* Loosen the screw from P3. Remove the screw from R1 to R2 if it is necessary. Re-tighten screws P3 and R1 or R2 according to table 5-1. (Figure 5.3.9-5) Put Plate IV and the screw back P4, but do not tighten it yet.
- \* Use the #5 Allen Key Wrench to loosen the screws from P, C and P2 on both sides of the seat base. Remove the screw from C to A, B or D if it is necessary. Re-tighten screws.(Figure 5.3.9-6)
- \* According to table 5-1, Replace screws on plate plates IV (A, B, C or D) and plate V (F1, F2, F3, F4, F5 or F6). Re-tighten all screws. (Figure 5.3.9-4)

5.3.9.4 Ensure all screw are properly tightened.

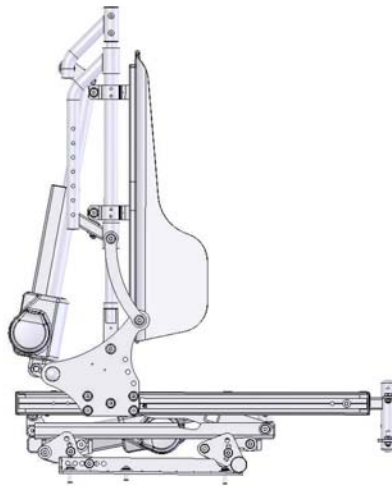

Figure 5.3.9-3

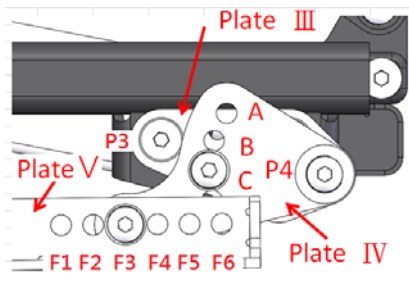

Figure 5.3.9-4

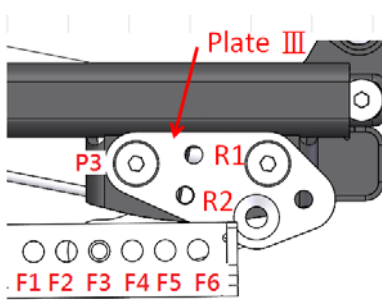

Figure 5.3.9-5

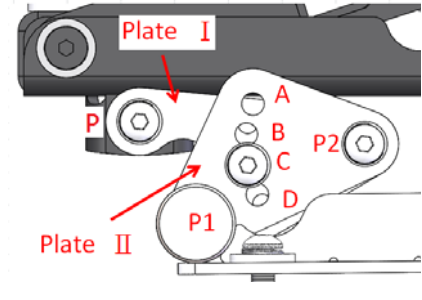
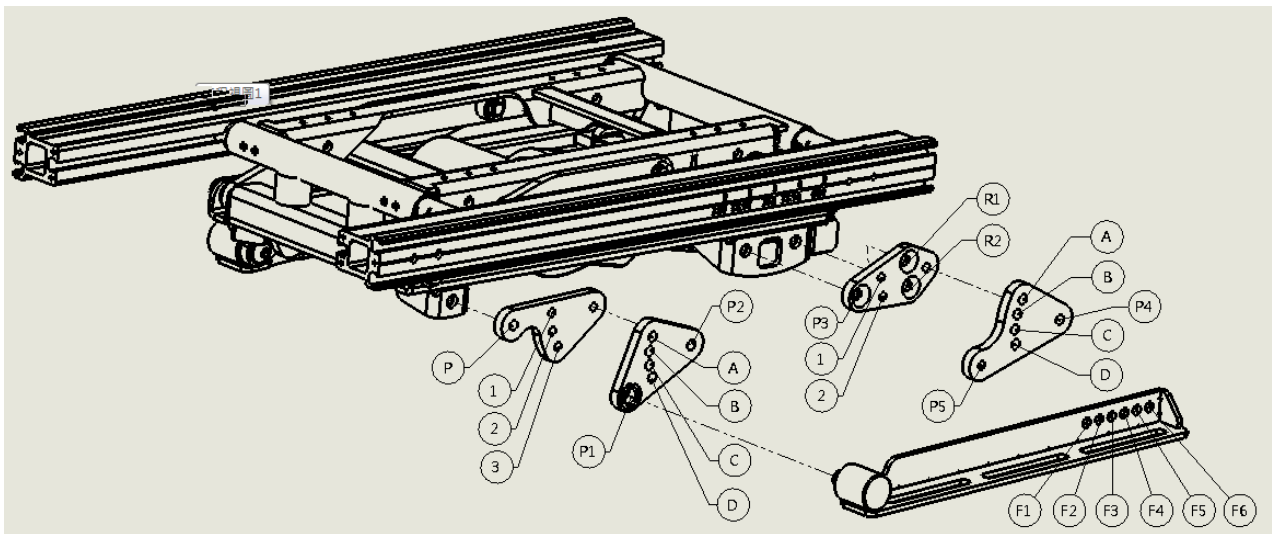

Figure 5.3.9-6

Table 5-1 : Kiss seat with tilting function



I	II	III	III	IV	IV	V	Seat Angle	Seat Height (Adult)	Seat Height (pediatric)
1 , B		R2	1 , C			P5 , F2	0	46.5	46.5
3 , C		R2	1 , B			P5 , F1	0	49	49
2 , A		R1	2 , B			P5 , F1	0	51	51
1 , A		R2	1 , B			P5 , F3	3	51	50.5
2 , A		R2	2 , B			P5 , F4	3	53.5	53
1 , A		R2	1 , C			P5 , F2	6	52	51
3 , B		R2	1 , B			P5 , F1	6	54	53
1 , B		R2	1 , B			P5 , F3	-3	46	46.5
3 , C		R2	2 , A			P5 , F5	-3	49	49.5
2 , B		R1	2 , A			P5 , F3	-6	46.5	47.5

Leon KISS Seat without Tilting Option (Including seat height adjustment) :

5.3.9.5 KISS Seat without Tilting option is shown as Figure 5.3.9-7.

5.3.9.6 Use the #5 Allen Key Wrench to loosen the screws from P, A and D on both sides of the seat base. (Figure 5.3.9-8) Remove the screw from R2 to R1 according to table 5-2 if it is necessary. But do not tighten it so far.

5.3.9.7 Remove screw A to 1, 3 or 4 according to table 5-2. (Figure 5.3.8-9)

5.3.9.8 Re-tighten all screws.

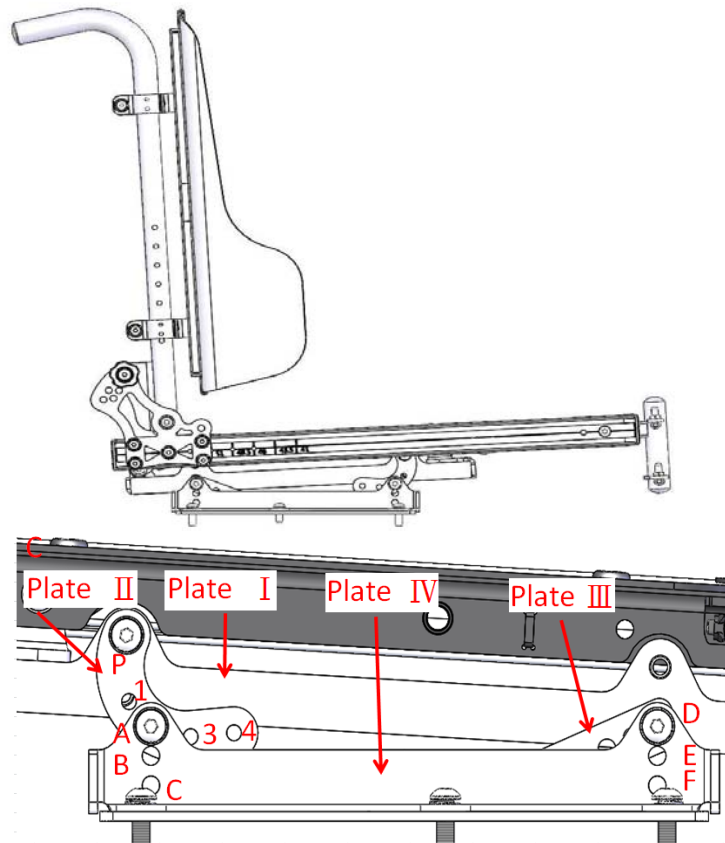

Figure 5.3.9-7

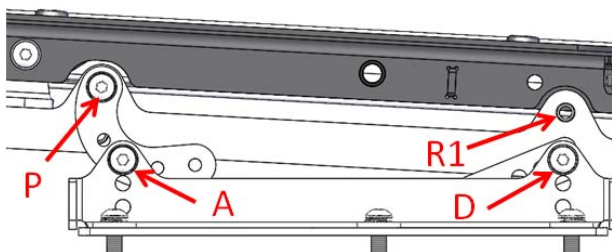

Figure 5.3.9-8

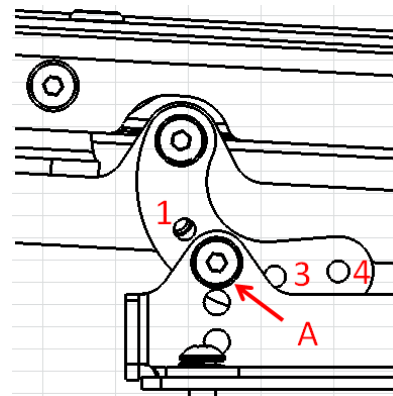
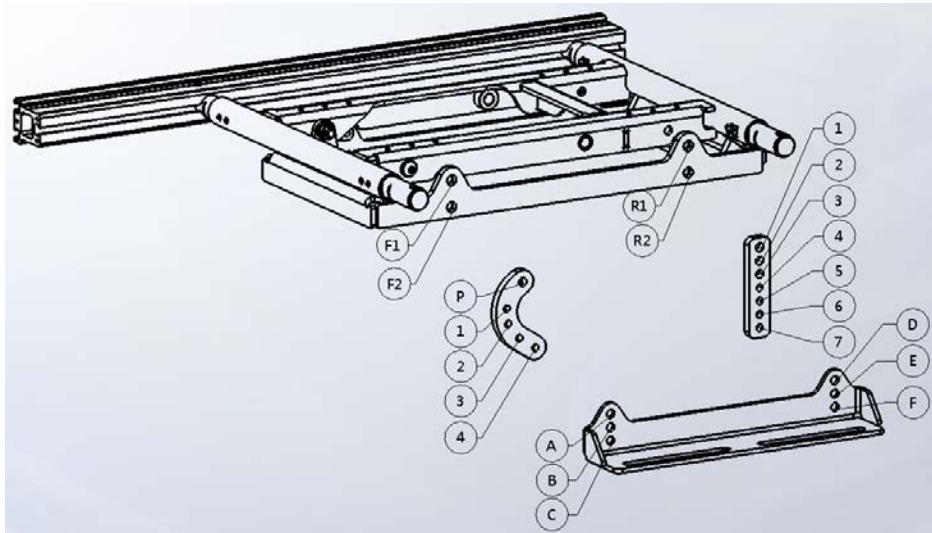

Figure 5-7.9

Table 5-2 : Kiss seat without tilting function



II	I	IV	II	III	I	IV	III	I	Seat Angle	Seat Height (Adult)	Seat Height (pediatric)
P, F1		B, 1		×		E, 1, R2			0	43.5	43.5
P, F1		A, 2		2, R1		E, 6/F, 7			0	46	46
P, F1		A, 4		2, R2		E, 6/F, 7			0	48.5	48.5
P, F2		A, 4		1, R2		D, 6/E, 7			0	51	51
P, F1		B, 1		×		F, 1, R2			3	45.5	45
P, F1		A, 2		×		D, 1, R2			3	48	47.5
P, F1		A, 4		3, R2		E, 6/F, 7			3	50.5	50
P, F2		A, 4		2, R2		D, 6/E, 7			3	53	52.5
P, F2		B, 2		×		E, 1, R2			6	49	48.5
P, F1		A, 4		2, R1		E, 6/F, 7			6	51.5	51
P, F2		A, 4		1, R1		D, 6/E, 7			6	54	53.5
P, F1		A, 3		×		E, 1, R2			9	52	51
P, F2		A, 3		2, R1		E, 6/F, 7			9	54	53

### 5.3.10 Backrest Angle Adjustment

Leon with Captain Seat :

5.3.10.1 The level for adjusting the backrest angle is at the left side in the lower back of the backrest. (Figure 5.3.10-1)

5.3.10.2 Hold the backrest frame with one hand, and adjust the backrest angle to your desired angle.( Figure 5.3.10-2)

5.3.10.3 Release the level when the desired angle is reached. If the seat width is 18" , the angle can be adusted from 0°~65°. If the seat width is 20" , the angle can be adusted from 0°~45°.



Figure 5.3.10-1



Figure 5.3.10-2

Leon with Sling Seat(Manual Recline) :

5.3.10.4 Behind the backrest, there is an adjusting knob for at eat side of it.

(Figure 5.3.10-3) Hold the backrest and use a 13mm open end wrench to remove knobs and nuts. Adjust the backrst to the desired angle.( Figure 5.3.10-4) Retighten knobs to fasten the backrest. The range of adjustable angle is between  $-1^{\circ}\sim 11^{\circ}$  .



Figure 5.3.10-3



Figure 5.3.10-4

Leon with KISS Seat(Manual Recline)

5.3.10.5 KISS Seat with manual reclining option is shown a Figure 5.3.10-5.

5.3.10.6 Remove nuts and knobs. Adjust the backrest angle to accommodate the user's needs. (Figure 5.3.10-6). Re-tighten all nuts and knobs

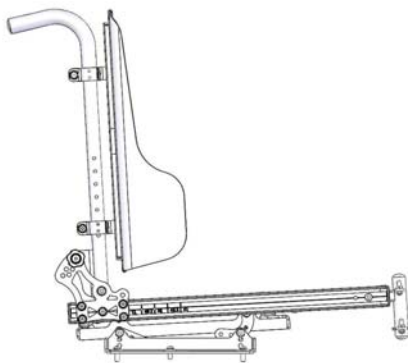

Figure 5.3.10-5

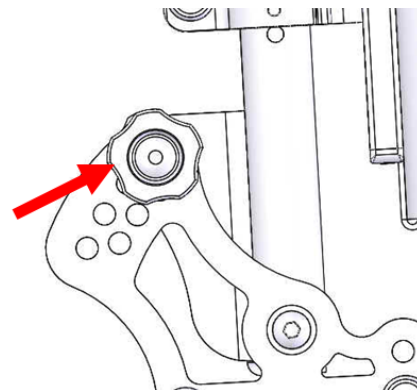

Figure 5.3.10-6

Leon with KISS Seat(powered Recline)

5.3.10.7 KISS Seat with powered reclining option is shown as Figure

---

5.3.10-7.

5.3.10.8 Select reclining function from the control screen. Recline the seat by operating the joystick. (Figure 5.3.10-8)

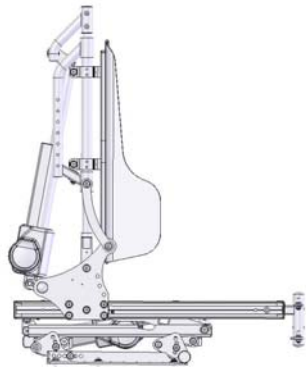

Figure 5.3.10-7



Figure 5.3.10-8

5.3.11 Headrest Adjustment

Leon with Captain Seat :

Press the button below the headrest, and adjust the location of headrest. (Figure 5.3.11-1 and 5.3.11-2)



Figure 5.3.11-1



Figure 5.3.11-2



Figure 5.3.11-3

Leon with Sling Seat :

Use the #4 Allen Key Wrench to loosen the screw below the headrest. There are four evenly spaced holes for incremental adjustments. The total range of adjustment is 50 mm. (Figure 5.3.11-3). Adjust the headrest to the desired position. (Figure 5.3.11-4, Figure 5.3.11-55, Figure 5.3.11-6, Figure 5.3.11-7)

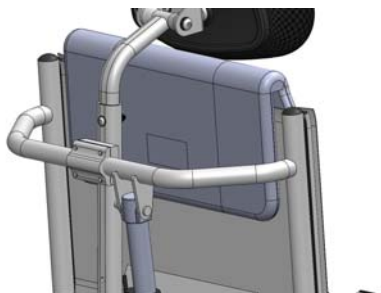

Figure 5.3.11-4

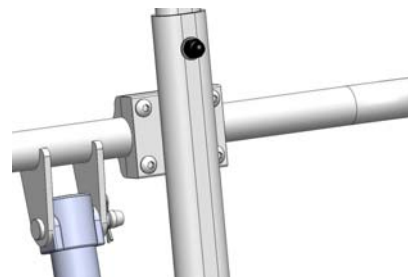

Figure 5.3.11-5



Figure 5.3.11-6

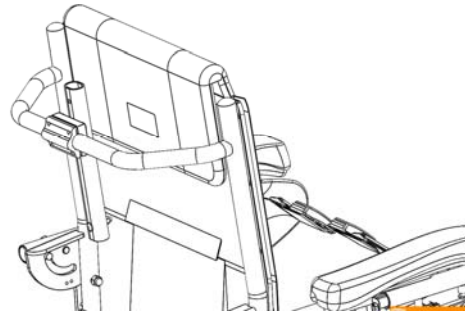

Figure 5.3.11-7

Leon with KISS Seat :

5.3.11.1 Adjustable headsupport is shown as Figure 5.3.11-8 and Figure 5.3.11-9.

5.3.11.2 Contour headsupport is shown as Figure 5.3.11-10 and Figure 5.3.11-11.

5.3.11.3 Use the #4 Allen Key Wrench to loosen the screws behind the headsupport. Adjust the headrest leftwards or rightwards to the desired position. ( Figure 5.3.11-12)

5.3.11.4 The headsupport can be removed by turning and loosening the lever A. ( Figure 5.3.11-13) When installing the headsupport back to the backsupport, be sure the pin B is in alignment with the slot C. (Figure 5.3.11-14, Figure 5.3.11-15) Turn and tighten the lever A.

5.3.11.5 Use the #3 Allen Key Wrench to loosen the screw D. The headsupport can be rotated or moved up or down. ( Figure 5.3.11-16)

5.3.11.6 Press the lever E. The headsupport can be folded. ( Figure 5.3.11-17)

5.3.11.7 By turning and loosening the lever F, the headsupport can be moved forwards or backwards. ( Figure 5.3.11-18)

5.3.11.8 Use the #5 Allen Key Wrench to loosen the screw G. The headsupport pad can be adjusted .( Figure 5.3.11.19)

5.3.11.9 Unzip the cover of the headsupport pad. Use the #5 Allen Key Wrench to loosen the screw H. The width of headsupport can be adjusted. ( Figure 5.3.11-20)



Figure 5.3.11-8



Figure 5.3.11-9



Figure 5.3.11-10



Figure 5.3.11-11

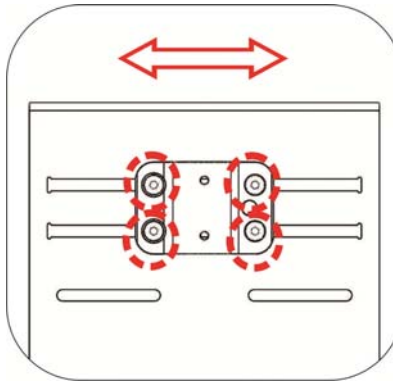

Figure 5.3.11-12

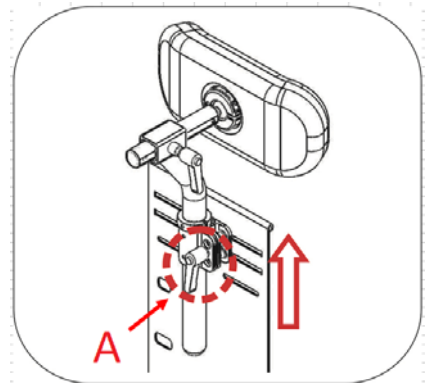

Figure 5.3.11-13

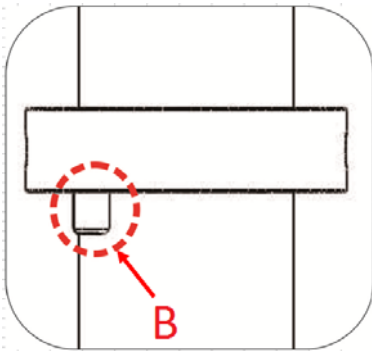

Figure 5.3.11-14

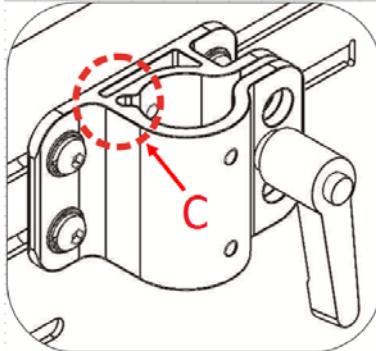

Figure 5.3.11-15

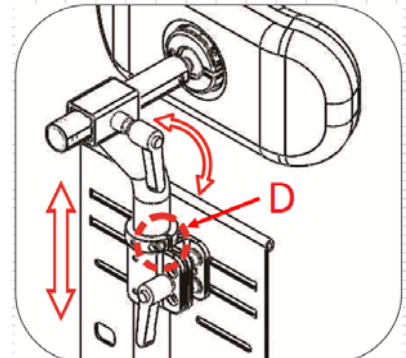

Figure 5.3.11-16

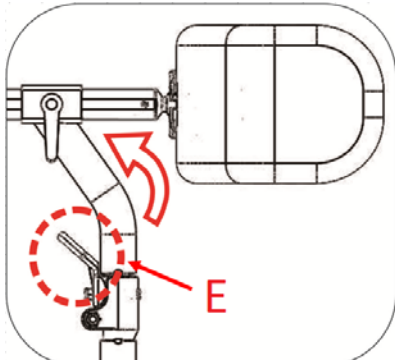

Figure 5.3.11-17

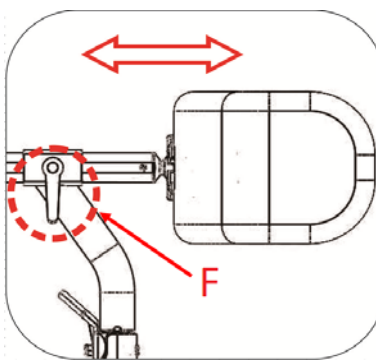

Figure 5.3.11-18

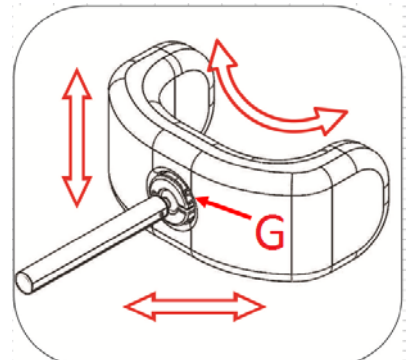

Figure 5.3.11-19

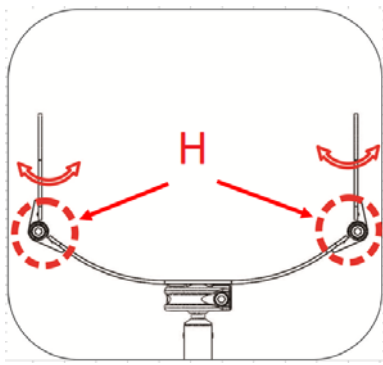

Figure 5.3.11-20

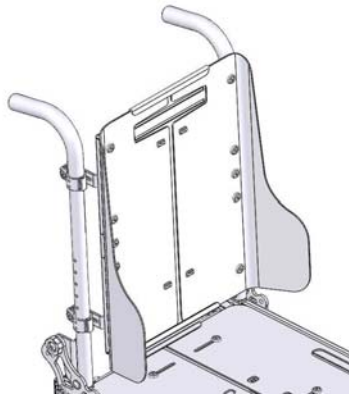

Figure 5.3.12-1

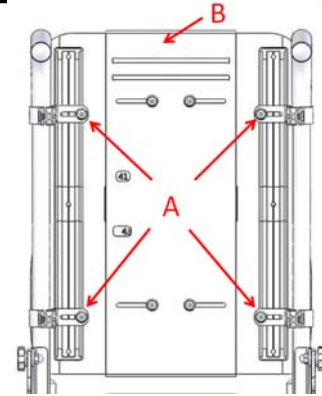

Figure 5.3.12-2

### 5.3.12 Backsupport Height Adjustment for KISS Seat

5.3.11.1 The backsupport is shown as Figure 5.3.12-1.

5.3.12.2 Use the #4 Allen Key Wrench to loosen the screws A. The plate B can be moved up or down for adjusting backsupport height.

Re-tighten all screws. (Figure 5.3.12-2)

### 5.3.13 Trunk Support Adjustment for KISS Seat

5.3.13.1 Trunk support is shown as Figure 5.3.13-1.

5.3.13.2 The trunk support can be removed from the seat by turning and releasing lever A. (Figure 5.3.13-2)

5.3.13.3 Upon pressing the shaft B, the trunk support can be swung outwards. (Figure 5.3.11-3)

5.3.13.4 Use the #4 Allen Key Wrench to loosen the screws C. The trunk support can be moved up or down. Re-tighten all screws. (Figure 5.3.13-4)

5.3.13.5 Use the #4 Allen Key Wrench to loosen the screws D. The trunk support can be moved forwards or backwards. Use the #4 Allen Key Wrench to loosen the screws E. The trunk support can be moved leftwards or rightwards. Re-tighten all screws. (Figure 5.3.13-5)

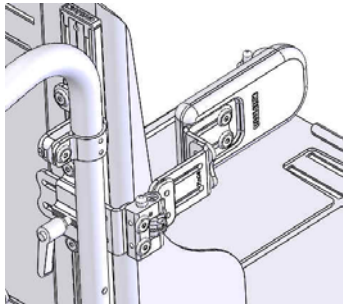

Figure 5.3.12-1

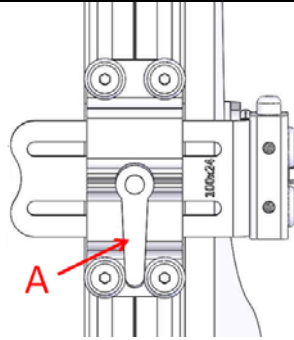

Figure 5.3.12-2

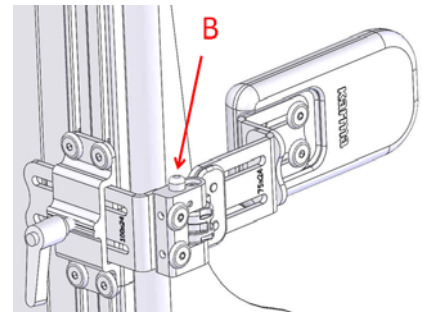

Figure 5.3.13-3

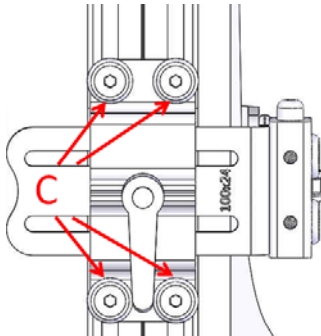

Figure 5.3.13-4

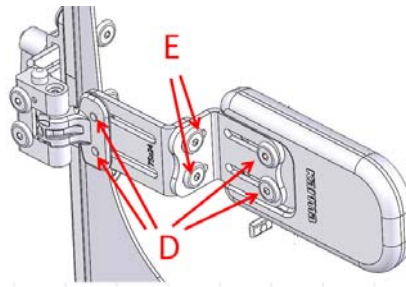

Figure 5.3.13-5

#### 5.3.14 Hip Supports Adjustment for KISS Seat

5.3.14.1 Hip support is shown as Figure 5.3.14-1.

5.3.14.2 Upon pressing the shaft A, the hip support can be swung outwards. (Figure 5.3.14-2)

5.3.14.3 Use the #4 Allen Key Wrench to loosen the screws B. The hip support can be moved forwards or backwards. (Figure 5.3.14-3)

5.3.14.4 Use the #4 Allen Key Wrench to loosen the screws C. The hip support pad can be moved up or down. Re-tighten all screws. (Figure 5.3.14-4)

5.3.14.5 Several holes can be selected to adjust the horizontal position of the hip support pad. Use the #4 Allen Key Wrench to remove the screws C. Move the hip support pad forwards or backwards. Re-tighten all screws. (Figure 5.3.14-4)

5.3.14.6 Use the #4 Allen Key Wrench to loosen the screws D. The hip support pad can be moved up or down. Re-tighten all screws. (Figure 5.3.14-5)

5.3.14.7 Use the #4 Allen Key Wrench to loosen the screws E. The hip support pad can be rotated or moved inwards or outwards.

---

Re-tighten all screws. (Figure 5.3.14-6)

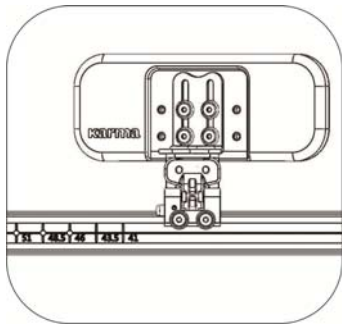

Figure 5.3.14-1

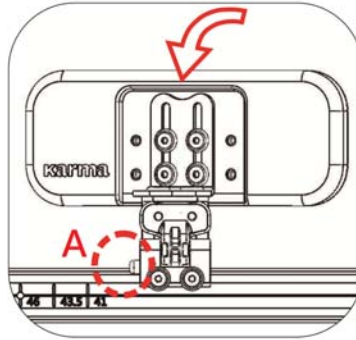

Figure 5.3.14-2

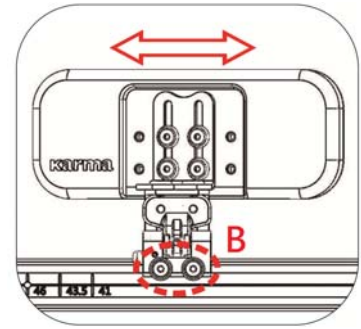

Figure 5.3.14-3

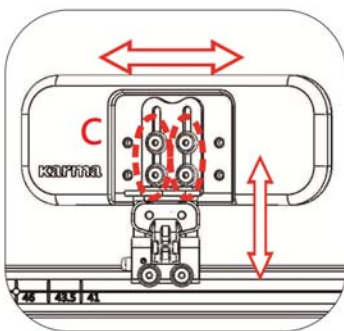

Figure 5.3.14-4

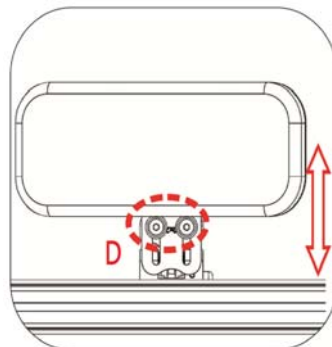

Figure 5.3.14-5

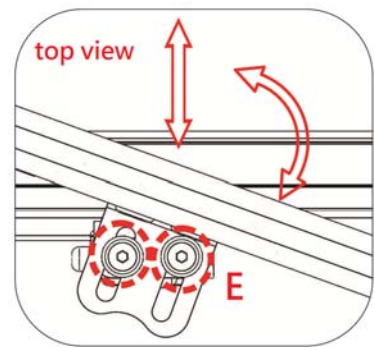

Figure 5.3.14-6

### 5.3.15 Pommel Adjustment for KISS Seat

5.3.15.1 Pommel assembly is shown as Figure 5.3.15-1.

5.3.15.2 Upon pressing the shaft A, the pommel can be swung outwards. (Figure 5.3.15-2)

5.3.15.3 Use the #4 Allen Key Wrench to loosen the screws B. The pommel can be moved leftwards or rightwards. Re-tighten all screws. (Figure 5.3.15-3)

5.3.15.4 Loosen the knob C. The pommel can be moved forwards or backwards. Re-tighten all screws. (Figure 5.3.15-4)

5.3.15.5 Use the #4 Allen Key Wrench to loosen the screws C. The pommel pad can be moved up or down. Re-tighten all screws. (Figure 5.3.15-5)

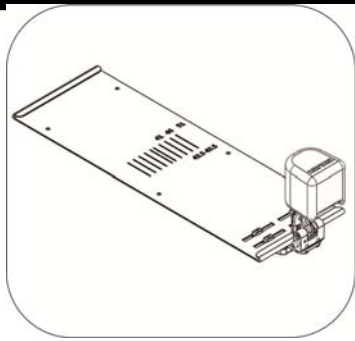

Figure 5.3.15-1

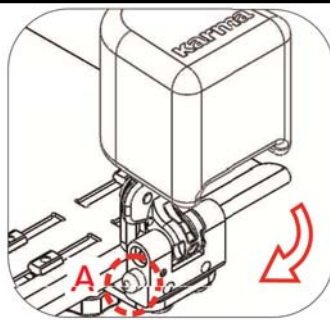

Figure 5.3.15-2

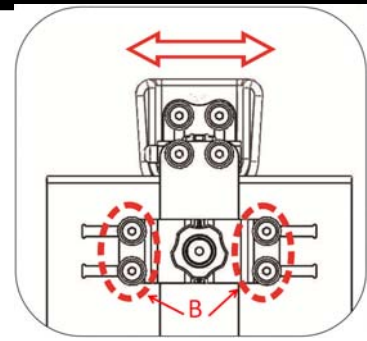

Figure 5.3.15-3

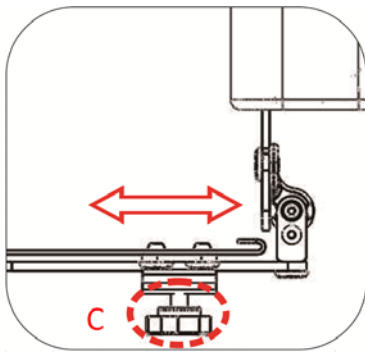

Figure 5.3.15-4

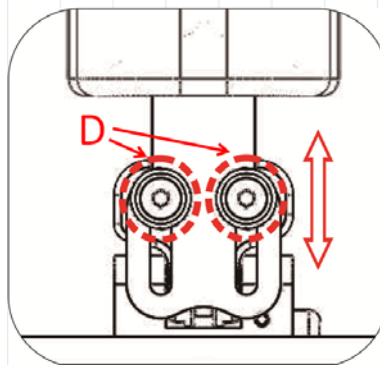

Figure 5.3.15-5

### 5.3.16 Pelvic Belt Adjustment for KISS Seat

5.3.16.1 The pelvic belt is shown as Figure 5.3.16-1.

5.3.16.2 Use the #5 Allen Key Wrench and the #13 box end Wrench to remove the screw and nut. The pelvic belt can be installed at point A, B or C. Re-tighten the screw. (Figure 5.3.16-2)

5.3.16.3 The pelvic belt can also be fixed at slot C to meet the user's needs. (Figure 5.3.16-2) In order to this replacement, the M8 Phillips Flat Round Head Screw and Nylon Insert Hex Nut have to be replaced by a M6 Phillips Flat Round Head Screw and a Square Nut. (Figure 5.3.16-3, Figure 5.3.16-4)

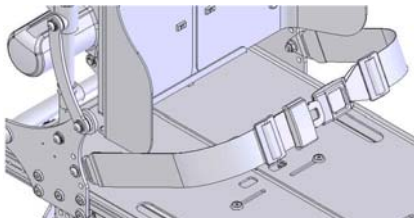

Figure 5.3.16-1

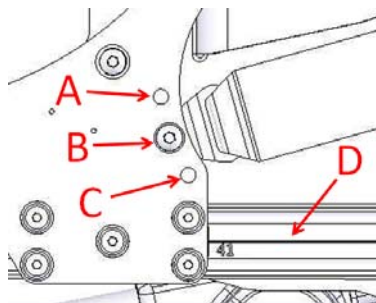

Figure 5.3.16-2

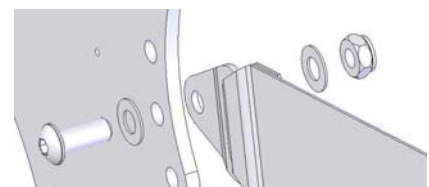

Figure 5.3.16-3

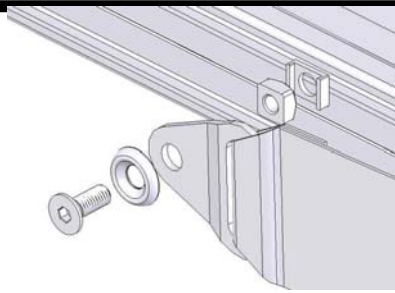

Figure 5.3.16-4

## 5.3.17 Transferring In and Transferring Out of the Powered Wheelchair

### Transferring In the Powered Wheelchair

5.3.17.1 Engage the freewheel levers and make sure that the controller is turned off.

5.3.17.2 Flip up the footplates and swing the footrest to the side.

5.3.17.3 Lower the user into the seat, and use the armrest for support.

5.3.17.4 Swing back the footrest and flip down the footplates so that the user can place his feet upon them.

5.3.17.5 Turn on the controller.

### Transferring Out of the Powered Wheelchair

5.3.17.6 Make sure that the chair is as close as possible to the place you're transferring to.

5.3.17.7 Engage the freewheel levers and make sure that the controller is turned off.

5.3.17.8 Flip-up the footplates and swing the footrests to the side.

5.3.17.9 Shift your body weight out of the wheelchair to the place you're transferring to.

## 5.3.18 Starting and Driving

5.3.18.1 Make sure the wheelchair is turned off.

5.3.18.2 Make sure the freewheel level is engaged.

5.3.18.3 Make sure the driver's seat is installed properly.

5.3.18.4 Make sure the armrests have been returned to the proper position.

5.3.18.5 Turn the power ON. If necessary, turn on the headlights and taillights.

5.3.18.6 Check the battery indicator and make sure there is enough power

---

for your trip(s). If you have any doubt about the remaining power, please charge the battery before you depart.

5.3.18.7 Set the speed dial to the proper level.

5.3.18.8 Be sure the controller is in good condition.

5.3.18.9 Make sure the electromagnetic brake is in good working order.

5.3.18.10 Always make sure that your surroundings are safe to operate the wheelchair.



#### CAUTION

**Do not turn the power OFF while driving, as this will lead to an abrupt stop and possible injury.**

**Do not set the speed dial on high while driving indoors.**

**Do not adjust the speed dial while driving. A sudden change to the highest speed may endanger you and cause failure to your wheelchair..**

**Do not place magnetic devices near the controller, as this may affect the operation of your wheelchair.**

**Be careful while driving in heavy traffic and crowded areas.**

**While reversing the vehicle be aware of the people and objects behind you.**

**If anti-tippers are standard equipped, DO NOT operate the wheelchair without anti-tippers being installed. Anti-tippers MUST BE attached at all times.**

#### 5.3.19 Installing the Seat Assembly on the Chassis



#### WARNING

**For your own security, read and obey all the instructions before proceeding the installation.**

If the seat assembly and the chassis are packed in different package when delivered, follow the following steps to install the seat :

##### Captain Seat:

5.3.19.1 Put the captain seat on the chassis (1) and move it forwards (2).

(Figure 5.3.19-1)

5.3.19.2 Ensure the bolt on the chassis to slide into the slot under the seat

(1). (Figure 5.3.19-2)

5.3.19.3 Use one M10\*35L button head hex socket screw, lock spring

washer and flat washer to fix the seat (3) from the front of the seat.

(Figure 5.3.19-3)

5.3.19.4 Ensure the seat that is properly fastened on the chassis. You can lift the seat up to test if it's loose. If, yes, please tighten all bolts.

5.3.19.5 Connect the controller joystick connector under the seat (2).

(Figure 5.3.19-2)

5.3.19.6 Install the right and left armrest, and also the right and left footrest.

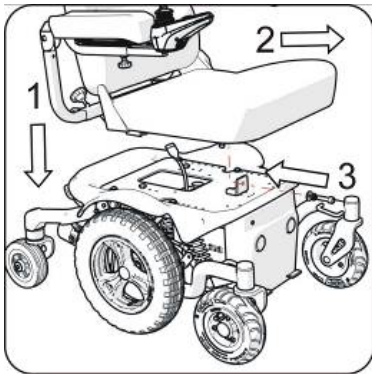

Figure 5.3.19-1

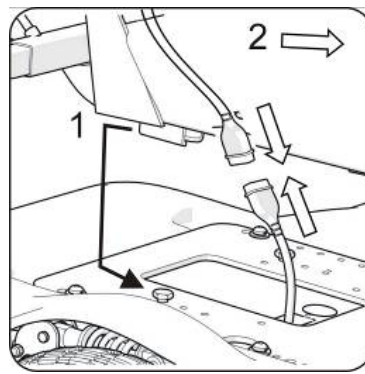

Figure 5.3.19-2

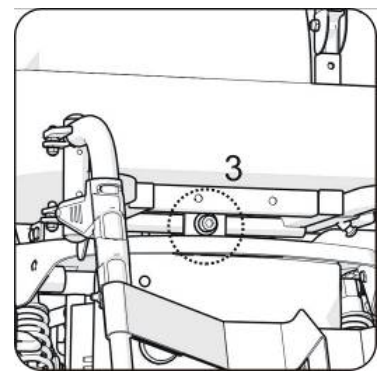

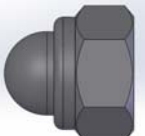





Figure 5.3.19-3

## Sling Seat :

### Parts

Item	Photos	Description	Quantity
A		Hex Head Shoulder Bolt	2
B		Hex Nylon Dome Nut M8	2
C		Tie	1
D		Clevis Pin *60L	1
E		M8*35LScrew+ M8 Nut	4

F		M8*16L Screw + Spring Washer + Flat Washer	2
G		M6*20L Screw + Cup Washer	2
H		M6*40L Screw + Cup Washer	2
I		E RING	1

5.3.19.7 Take the seat assembly out of the package. (Figure 5.3.19-4)

5.3.19.8 Erect the backrest to the upright position in order to make it easier to install the recline actuator. (Figure 5.3.19-5)

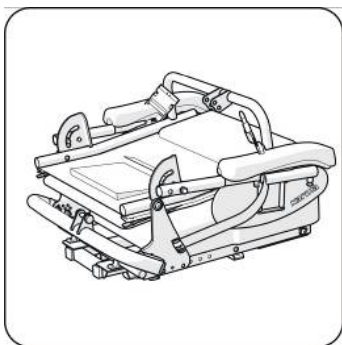

Figure 5.3.19-4



Figure 5.3.19-5

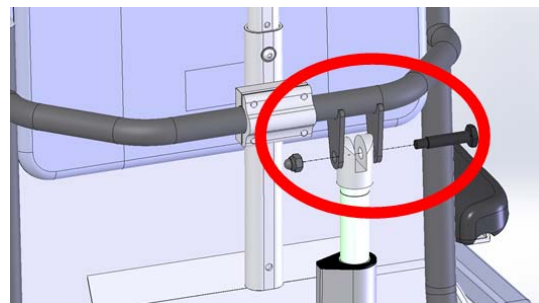

Figure 5.3.19-6

5.3.19.9 Insert the hex head shoulder bolt through the top hole of the recline actuator. Use hex Nylon dome nut to fix the bolt. (Figure 5.3.19-6)

5.3.19.9 Use part C to tighten the cable of recline actuator on the Aluminum tube. (Figure 5.3.19-7)



**CAUTION**

Make sure the cable is properly routed to prevent it from being damaged or pulled when the actuator is operated between the uppermost position and the lowermost position.



Figure 5.3.19-7

5.3.19.10 Take the tilt actuator and the fixing bracket out of the package. Insert the Clevis pin through the lower hole on the rod of the tilt actuator. Insert E ring into the slot of the pin in order to fix the tilt actuator on the fixing bracket. (Figure 5.3.19-8)



**CAUTION**

Part Clevis Pin shall be inserted into to the lower hole.



**CAUTION**

Do not insert part Clevis Pin into to the upper hole.

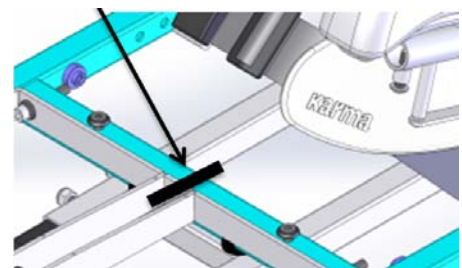
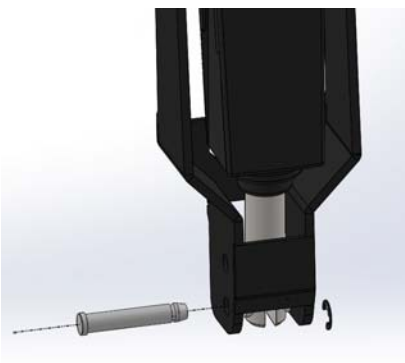

Figure 5.3.19-8

Figure 5.3.19-9

5.3.19.11 Cut the tie which is used to fasten the seat frame and the fixing base before installing the fixing bracket in the fixing base. (Figure 5.3.19-9)

5.3.19.12 Use part E to fasten fixing bracket on the seat frame. There are four sets of screws and nuts. Two sets are used for either side. (Figure 5.3.19-10)

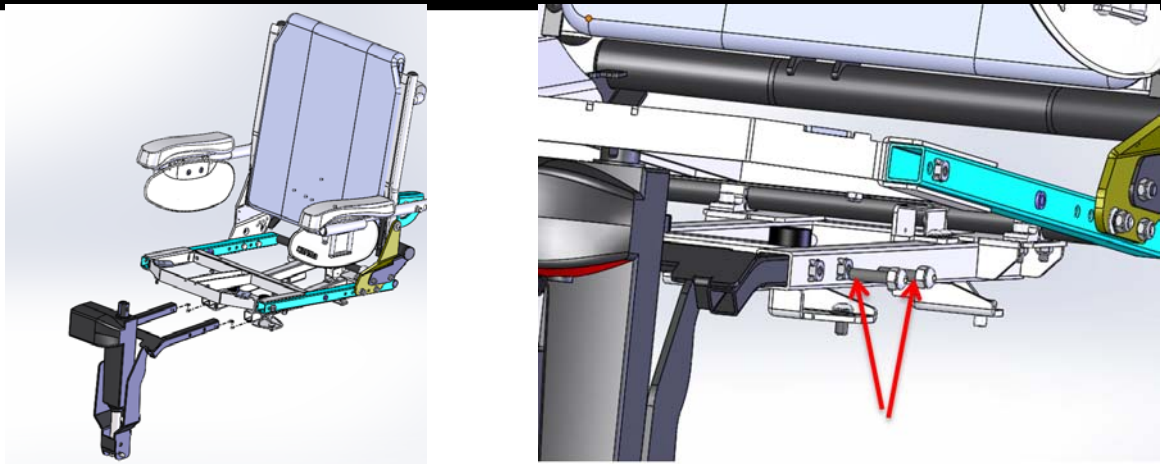

Figure 5.3.19-10

5.3.19.13 Insert hex head shoulder bolt into the upper hole on the base of the tilt actuator. Use the hex Nylon dome nut to fasten the bolt in order to fix the tilt actuator on the seat frame. (Figure 5.3.19-11)

5.3.19.14 Connect the connector of the tilt actuator to the connector fixed on the right side of the seat frame. (Figure 5.3.19-12)

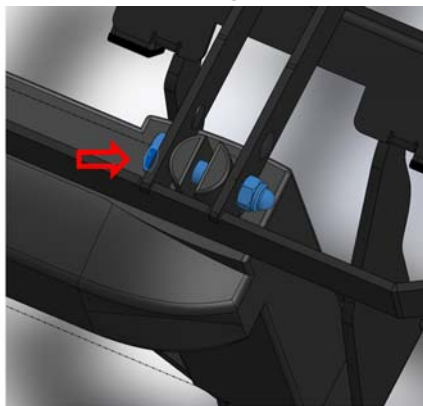

Figure 5.3.19-11



Figure 5.3.19-12



**CAUTION**

Ensure the hex head shoulder bolt is installed at the correct position when installing the seat. Use Loctite 243 when installing the bolt.



**CAUTION**

When insatlling a captain seat, the hex head shoulder bolt is installed at position A. (Figure 5.3.19-13)



## CAUTION

When insatlling a sling seat, the hex head shoulder bolt is installed at position B. (Figure 5.3.19-14)

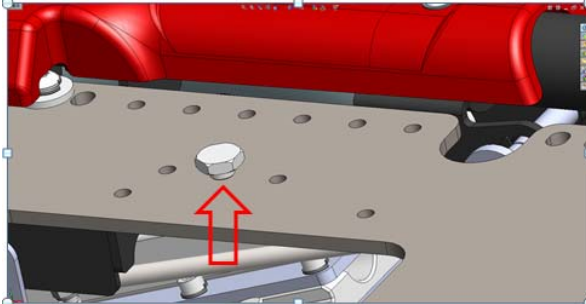

Figure 5.3.19-13

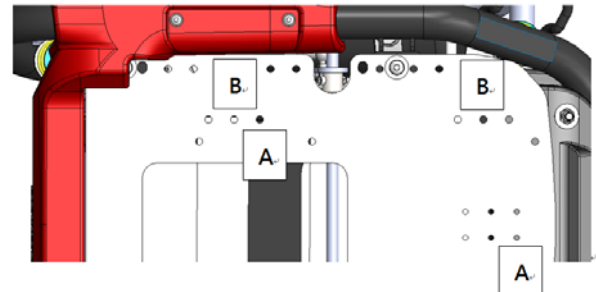

Figure 5.3.19-14

5.3.19.15 Put the rear part of the seat assembly on the interface plate.  
(Figure 5.3.19-15)

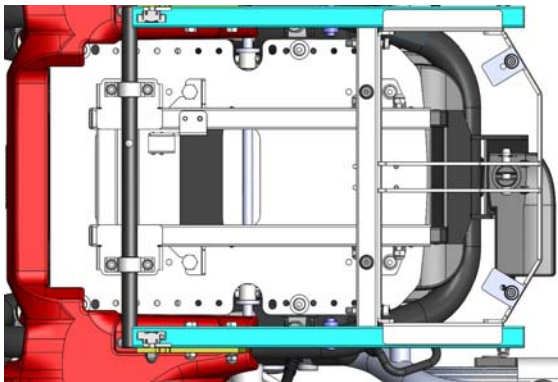

Figure 5.3.19-15

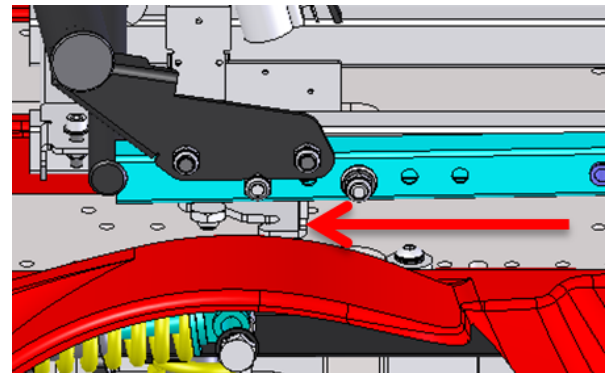

Figure 5.3.19-16

5.3.19.16 Push the seat backwards and ensure the fixing pins on the interface plate are properly seated in the slots under the seat frame. (Figure 5.3.19-16)

5.3.19.17 Use part F to fix seat frame. Make sure the two screws are properly tightened. (Figure 5.3.16-17)

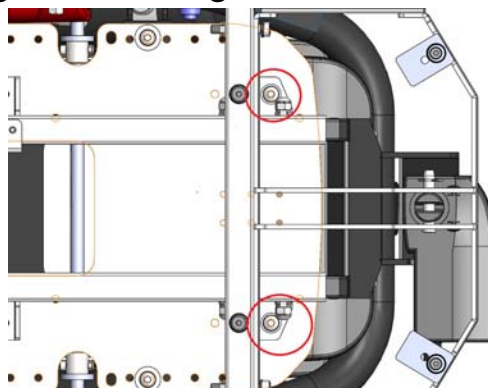

Figure 5.3.19-17

5.3.19.18 Connect cables of tilt actuator, recline actuator, speed limitation, angle limitation and the controller which are under the seat.

(Figure 5.3.19-18)

	<b>CAUTION</b>
<b>Ensure all cables are appropriately connected. Each can be identified by the color or the type of connectors.</b>	

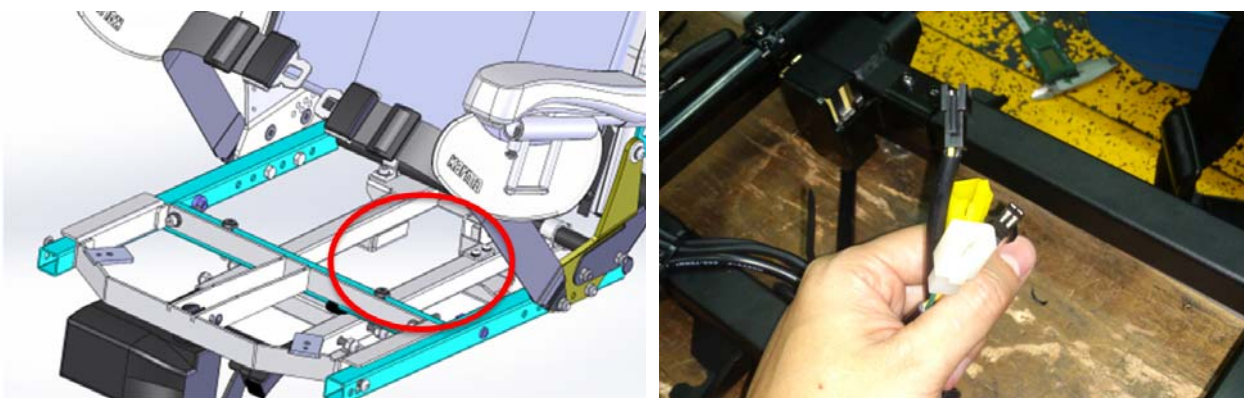

Figure 5.3.19-18

5.3.19.19 Use part G and H to fasten the seat plate on the seat frame. (Figure 5.3.19-19)

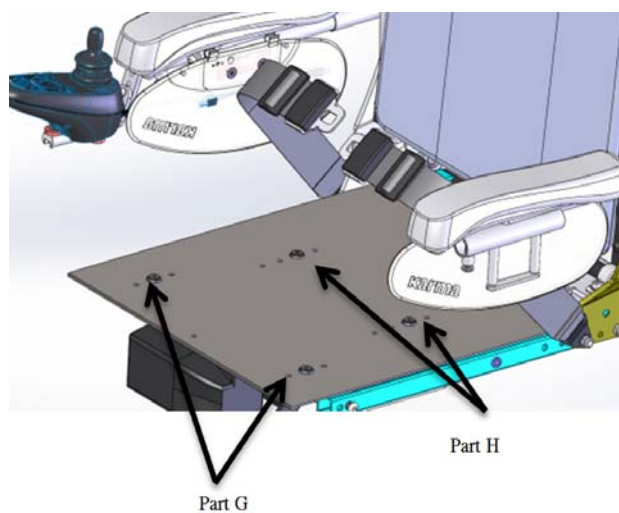

Figure 5.3.19-19

5.3.19.20 Reinstall new version of parameters of the controller.

5.3.19.21 Drive the wheelchair when the seat is reclined to the lowermost position. If the wheelchair is inhibited from driving, please adjust the switch. (Figure 5.3.19-21)



## CAUTION

In some situations, it could be not safe to recline or tilt the seat when driving on a slope. For safety, the switch is used to inhibit the user from reclining or tilting the seat when driving on the slope.

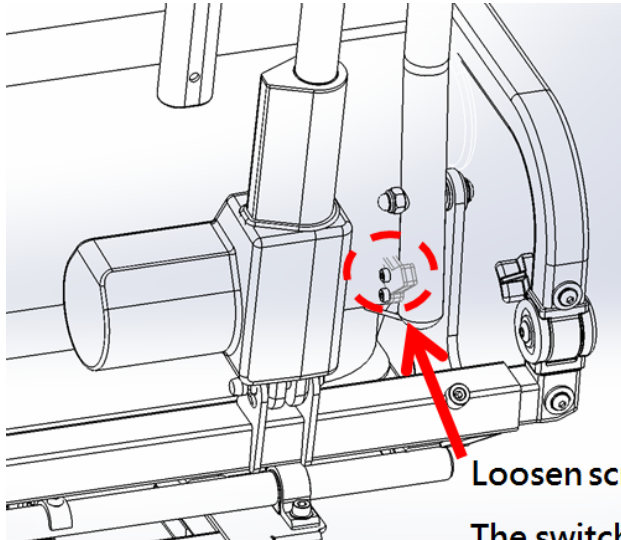

Figure 5.3.19-21



## WARNING

After completing this installation, do operate the wheelchair to assure it works without malfunctions.

### 5.3.17 Transportation

The wheelchair is not suitable to use as a seat in vehicles . KARMA always recommend that the user transfers to the vehicle seating.



## WARNING

The wheelchair cannot be used as seats in any vehicles. That is, KARMA recommends that users are NOT transported in any vehicle while seated in the wheelchair. In the case of accident or a sudden stop, the user could be thrown from the wheelchair and get injured. The suggested solution is to transfer the user from the wheelchair into a normal seat of the vehicle and to securely stow the wheelchair in a separate compartment.

## 6. BATTERIES AND CHARGER

Except the joystick control panel can be operate by the occupant, other operations should be carried out by an assistant.

Anything wheelchair related that requires tools should be done by your authorized Karma service provider.

## 6.1 Charging the Batteries

Before you attempt charging, ensure you read and understand the instruction manual supplied with the battery charger, and you choose the correct input voltage for battery charger.

## 6.2 Charge the Batteries If Any of the Following Conditions Occurs

6.2.1 You have used your wheelchair for more than an hour continuously.

6.2.2 You've used more than one quarter of the total charge.

6.2.3 When you haven't used the wheelchair for more than two weeks.

6.2.4 If the current charge is not enough to reach your final destination.

## 6.3 Be Sure to Precisely Follow the Procedures Listed Below.

6.3.1 Turn the wheelchair OFF.

6.3.2 Connect the charger's cord to a power outlet.

6.3.3 Then connect the charger's round plug (Figure 6-1) to the charging socket. (Figure 6-2)

6.3.4 The orange LED will light up as soon as the charging starts. The charging time is at least 8 hours, but it could be as long as 12 hours, depending on the status of the batteries and the temperature.

6.3.5 The orange LED will change to green when the charging is completed.

6.3.6 Turn off the charger, disconnect the cord and pull out the round plug from the charging socket.



Figure 6-1

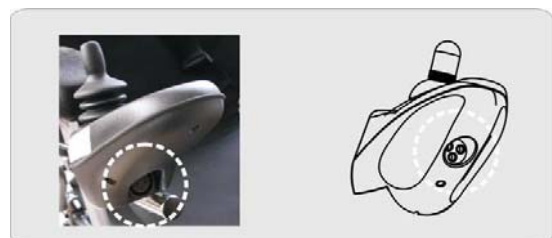

Figure 6-2



### SUGGESTION

**Do not disconnect the charger cord if the charging is not completed. The battery life will be seriously shortened or decayed if the batteries are repeatedly used without being fully charged. Therefore, be sure to always charge the batteries fully.**

Always complete the charging when the LED light turns green. NEVER stop charging before it is completed.

When finished charging, disconnect the charger plug from the charging socket as soon as possible. Even when the charger is turned OFF, the electric power will slowly discharge if the cord is not disconnected. DO NOT leave the charger ON connected to the wheelchair for more than 12 hours.

Charging time depends on the surrounding temperature; it takes longer in the winter.



## CAUTION

Please follow the guidelines below to avoid accidents while charging. Be sure to only use a KARMA approved battery charger and charge the battery completely every time. The battery can be damaged if a non-genuine charger is used.

Never disassemble or modify the charger. This will void the warranty. Please charge in a well-ventilated area where the battery is not directly exposed to sunlight. Do not charge the battery under rainfall, in morning dew or in an area where the humidity is high.

Do not cover the wheelchair with any waterproof cloth or other objects while charging. Don't charge in temperatures lower than -10°C(14°F) or higher than 50°C(122°F) as the charger may not work well and the battery may become damaged.

- The charger is not guaranteed to be water resistant.

Valve Regulated Lead-Acid batteries do not have a memory function like cell phone batteries have. Please get in the habit of recharging your VRLA batteries frequently.

New batteries MUST be fully charged prior to initial use of the powered wheelchair.

Always charge new batteries before initial use or battery life will be reduced.

As a general rule, recharge batteries as frequently as possible to assure the longest possible life and to minimize required charging time. Plan to recharge them when use of the powered wheelchair is not anticipated.



## WARNING

Keep your wheelchair away from flammable objects while charging, as it may lead to fire or explosion of the battery.

When the batteries are charged, they may produce hydrogen. Therefore, do not smoke while charging and charge in a well-ventilated area.

Never connect or disconnect the plug (cord) with wet hands or if the plug (cord) is wet to avoid possible electric shock.

Never attempt to recharge the batteries by attaching cables directly to the battery terminals or clamps. DO NOT jump start your wheelchair!

Do NOT attempt to recharge the batteries while the powered wheelchair is in operation.

---

## 6.4 Charger

The battery charger supplied by Karma is for indoor use only, it must be protected from moisture and external heat source.



### CAUTION

Before charging, make sure to set the 115V ↔ 230V switch to match the local AC voltage. If the switch is improperly set to a lower or higher voltage position, it will cause damage to the charger, and, char↔ the 115V ↔ 230V switch settings only when charger is disconnected from AC line voltage.



### WARNING

The fan inside the charger will start to work when you turn on the charger. (for 8A charger will start to work as the temperature reaches higher than 50°C and stop running when the temperature is lower than 50°C) If you find that the fan does not function properly, DO NOT use the charger. Otherwise, the charger may overheat and start a fire.

## 6.5 Batteries

- 6.5.1 Do not expose the batteries to temperatures below -10°C(14°F) or above 50°C(122°F) when charging or storing the vehicle.
- 6.5.2 Exceeding the specified temperature range can lead to either freezing or overheating of the batteries. This will damage the batteries and shorten their lives.
- 6.5.3 The batteries used on your wheelchair are maintenance free sealed lead acid batteries. Thus, it is not necessary to change or refill the battery liquid.



### WARNING

Do not open the battery seal cap at any time.  
After ANY adjustments, repair or service and BEFORE use, make sure that all hardware is tightened securely. Otherwise, injury or damage may occur.  
When removing/installing batteries, keep all foreign objects, especially metal, away from battery terminals.  
When the batteries fail to function, for environmental and safety concerns, please contact any local recycle unit or KARMA supplier/dealer to handle them.



### CAUTION

Place the powered wheelchair in a well-ventilated area where work can be performed without risking damage to carpeting or floor covering. Failure to use the correct battery size and/or voltage may cause damage to the powered wheelchair and give unsatisfactory performance. For replacement of batteries, please contact your local KARMA supplier/dealer in order to ensure that the new batteries are correctly be used.

Wheelchair MODEL	QTY	VOLTS	AMP/HOURS
Leon	2	12	50



### WARNING

NEVER allow any of your tools and/or battery cables to contact BOTH terminal posts at the same time. An electrical short may occur and injury or damage may occur.



### CAUTION

When tightening the clamps, always use a box or crescent wrench. Pliers will round off (strip) the nuts. NEVER wiggle the terminal when tightening, as the battery may be damaged.



### SUGGESTION

Charge batteries daily. It is critical not to let them run low at any time. Do not use the battery to charge telecom equipment or other items. Battery capacity will vary with outside conditions; the maximum drive range will decrease in the winter. If the vehicle is not going to be used for a long time, please remember to charge the batteries at least once every two weeks. Karma recommends that both batteries be replaced if one battery is defective.

## 6.6 Cleaning the Batteries

If a battery is contaminated by dirty water, battery acid, dust or other soil, the battery will discharge quickly. Therefore, please follow the following steps to clean the battery:

6.6.1 Turn the power OFF ;

---

6.6.2 Use a clean cloth to wipe off the soiled part of the wheelchair around the battery.

6.6.3 Clean the terminals and inside of the battery clamps by using a battery cleaning tool, wire brush or medium grade sandpaper. Upon completion, these areas should be shiny, not dull.

6.6.4 Examine the battery clamps/terminals for corrosion, if the terminal is covered by white powder, please stop using the battery due to it indicates that there's possible leakage of the battery. Please replace the batteries.

6.6.5 Carefully dust off all metal particles.

## 6.7 Replacing the Batteries

Karma strongly recommends that battery replacement and installation always be done by a qualified technician. To replace the batteries, please refer to the photo below of the batteries equipped on the Leon series, and follow the below instructions to remove and load the batteries. The weight of one battery could be more than 10 kg. Please handle it with care.



### WARNING

**Do turn off the power of the wheelchair before replacing or loading the batteries.**

**Do NOT allow conductive material such as a wrench to contact BOTH battery terminals at the same time. This will result in a short that can cause burns to you and damage the battery.**

**Most batteries are not sold with instructions. However, warnings are frequently noted on top of the batteries. Read them carefully.**

**Do NOT allow the liquid in the battery to come in contact with skin, clothes or other items. It is a form of acid and may cause harmful or damaging burns. Should the liquid come into contact with skin, rinse the area immediately and thoroughly with cool water. If liquid comes into contact with eyes, flush eyes immediately and seek medical attention as soon as possible.**

**The use of rubber gloves and chemical goggles are recommended when working with batteries.**

**NEVER smoke or strike a match near the batteries.**

**Replace the batteries IMMEDIATELY if there are any cracks or leaks.**

### 6.7.1 Remove the Batteries

Remove the Front Battery

6.7.1.1 Remove the two screws on the battery casing in the front of the wheelchair.(Figure 6-3)

6.7.1.2 Remove the battery casing.(Figure 6-4)

6.7.1.3 Unfasten the battery strap.(Figure 6-5)

6.7.1.4 Place the front casing aside, and pull the lighting connectors and the battery connectors out. (Figure 6-6)

6.7.1.5 Unplug the lighting connectors.(Figure 6-7)

6.7.1.6 Disconnect both wire terminals of the battery. Cap the wire terminals to avoid any short circuit. (Figure 6-8)

6.7.1.7 Hold the front battery and slightly pull it out. (Figure 6-9)

6.7.1.8 Place the front battery on the ground. Put aside the wires detached from the front battery and keep them away from touching the terminals of the batteries to avoid any short circuit. (Figure 6-10)



Figure 6-3

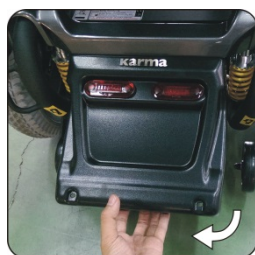

Figure-6-4



Figure 6-5



Figure 6-6



Figure 6-7



Figure 6-8



Figure 6-9

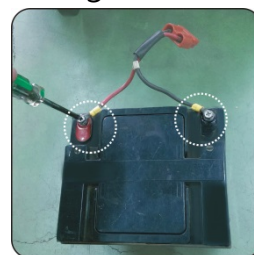

Figure 6-10



Figure 6-11



Figure 6-12



Figure 6-13

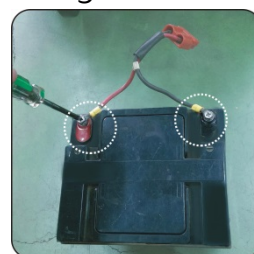

Figure 6-14

### Remove the Rear Battery

6.7.1.9 Unfasten the battery strap. (Figure 6-11)

6.7.1.10 Disconnect both wire terminals of the battery. (Figure 6-12)

---

6.7.1.11 Hold the rear battery and slightly pull it out. (Figure 6-13)

6.7.1.12 Place the rear battery on the ground. Put aside the wires detached from the rear battery and keep them away from touching the terminals of the batteries to avoid any short circuit. (Figure 6-14)

## 6.7.2 Load the Rear Battery:

6.7.2.1 Load the rear battery back into the battery box.(Figure 6-15). Connect the red wire with the positive terminal (the **RED** end). Connect the black wire with the negative terminal (the **BLACK** end). Make sure the terminals are properly connected.

6.7.2.2 Before placing the battery inside the battery box, connect the battery cable to the power cable connectors. (Figure 6-15)

6.7.2.3 Fixate the wires and the battery by pulling firmly on the battery strap. (Figure 6-16)



Figure 6-15



Figure 6-16



Figure 6-17

## 6.7.3 Load the Front Battery:

6.7.3.1 Load the battery back into the battery box. Connect the red wire with the positive terminal (the **RED** end). Connect the black wire with the negative terminal (the **BLACK** end).

6.7.3.2 Before placing the battery inside the battery box, connect the battery cable to the power cable connectors. (Figure 6-17)

6.7.3.3 Adjust the strap first to so that the remaining end of the strap is not protruding out of the battery box.

6.7.3.4 Fixate the wires and the battery by pulling firmly on the battery strap. Fasten the strap firmly. (Figure 6-18)

6.7.3.5 Re-tighten the screws on the battery casing. (Figure 6-19)



Figure 6-18



Figure 6-19



## WARNING

There are many risks involved with improper disposal of batteries, whether damaged or not. Batteries may contain heavy metals and be considered hazardous waste.

Many regions around the world now strictly enforce laws to help protect our environment. By not disposing of batteries properly, you may be liable for fines from your local through national government.

By not recycling batteries, they end up in landfills where lead and other chemicals may leach into streams and rivers destroying ecosystems and poisoning local water resources.

Improper disposal of batteries may also cause injury to unsuspecting others that come in contact with them. If you come in contact with fluids or corroded powder from a battery, rinse with water and contact a physician if necessary. If contact with eyes occurs, rinse for 15 minutes and then visit a physician.

**DO NOT incinerate or burn the battery. It will cause it to explode!**  
Please see the end of Section 11. Cleaning & Recycling for more information.



## SUGGESTION

If necessary or if you have any question in the above procedures, ask for help from your KARMA wheelchair dealer for cleaning and replacing the batteries.

## 7. INSPECTION AND MAINTENANCE

### 7.1 Daily Check

Check the following items before driving. If you find anything abnormal, visit your KARMA wheelchair dealer for further inspection before using it.

Item	Inspection Content
Joystick Controller	<ul style="list-style-type: none"> <li>- Is the joystick loose and/or making noise?</li> <li>- Can the joystick be turned left and right smoothly?</li> <li>- Can the speed buttons be adjusted freely and do</li> </ul>

	<p>they function well?</p> <ul style="list-style-type: none"> <li>- Does the wheelchair stop when the joystick is released completely?</li> <li>- Does it light up when the power is ON?</li> <li>- Is there enough power for your trip?</li> <li>- Does the horn work well?</li> </ul>
Motor	<ul style="list-style-type: none"> <li>- Is there any abnormal noise?</li> <li>- Does the electromagnetic brake work properly?</li> </ul>
Freewheel Mode	<ul style="list-style-type: none"> <li>- Do the freewheel levers work properly?</li> </ul>
Driver's Seat	<ul style="list-style-type: none"> <li>- Does the driver's seat recline? (if applicable)</li> <li>- Do the seat angle adjustment knobs(or buttons) work properly?</li> <li>- Does the surface of the seat remain or break?</li> </ul>
Tires	<ul style="list-style-type: none"> <li>- Are there any cracks or other damage to the tires?</li> <li>- Check the tire tread depth and air pressure.</li> </ul>
Other	<ul style="list-style-type: none"> <li>- Is there any abnormal motor noise?</li> </ul>



## CAUTION

Except the joystick control panel can be operate by the occupant, other operations should be carried out by an assistant. Anything wheelchair related that requires tools should be done by your authorized Karma service provider.

Visit or contact a KARMA dealer for inspection and maintenance if you find anything abnormal.

## 7.2 Regular Maintenance Record

To make sure your wheelchair is in good condition, visit your KARMA wheelchair dealer regularly for maintenance(and keep records accordingly ) every six months after purchasing. A maintenance/service fee may apply.



## SUGGESTION

Even if you don't use the wheelchair for a long time, the wheelchair should still be maintained regularly.  
You should clean your wheelchair, inside and out, regularly to keep it beautiful and safe.

I - Inspection

A - Adjustment

Δ - Repair

3 - Replacement

T - Tightening

L - Add Oil

Item/Period		1 mth	6 mth	12 mth	18 mth	24 mth	30 mth
Moving Parts (Refer to Section 7.7)		L					
Joystick Control Unit			I	I	I	I/3	I/3
Power Module			I	I	I	I/3	I/3
Controller Buttons			I	I	I	I/3	I/3
Connection to the Electrical System				I		I	I/A
Motor	Operation and Noise		I	I	I/A	I/A	I/3
	Electromagnetic Brakes		I	I	I	I/3	I/3
	Connection to the Electrical System			I		I	
Battery	Loose or Corroded Terminals			I		I	
	Connection to the Electrical System			I		I	
	Damage to the Electrical Cord/Cable			I		I	
Charger	Charging Function and LED Light	I	I	I	I/Δ	I/Δ	I/Δ
	Socket, Plug and Cords			I		I	
	Fan Functions Properly (if applicable)			I		I/Δ	
Driver's Seat	Recline Function(if applicable)			I/L		I/L	

Item/Period		1 mth	6 mth	12 mth	18 mth	24 mth	30 mth
Tires	Cracks/Surface Damage	I/3	I/3	I/3	I/3	I/3	I/3
	Tread Depth		I	I/3	I	I/3	I
	Abnormal Wear Pattern			I/3		I/3	
Wheel	Tightness of Bolts and Nuts			T		T	
Rim	Wear or Deformation Around Tires			I/3		I/3	

### 7.3 Tires

7.3.1 The condition of the tires is affected by the way you drive and use your wheelchair.

7.3.2 Inspecting Tire Tread: please check the tread depth regularly.

7.3.3 Replace the tires when the tread depth is less than 0.5 mm.

7.3.4 The tires could be pneumatic or PU tires. It depends on the specification of the wheelchair. If they are pneumatic tires, please refer to the tires pressure specified on the tire walls to maintain the tires at the correct pressure. Do not let anyone touch the wheels when the wheelchair is in motion to avoid pinch injury.



#### CAUTION

When the tread depth is below 1 mm, the tire does not have good traction. This may lead to vehicle slippage and makes braking distances much longer. Thus, go to your Karma dealer to replace the tire as soon as possible if it has less than a 1 mm tread depth.

The tire pressure of all the front casters and the rear wheels must be kept at 35-40 PSI (approx. 2.46~2.81 kg/cm or 2.415~2.76 bar=241-276 kPa) for the best drive range (maximum distance travelled per charge) and usage/ handling. Please refer to the tire pressure specified on the tire walls to maintain the tires at the correct pressure.

### 7.4 General Maintenance

7.4.1 You must maintain the vehicle more frequently if you drive on grass, sand or gravel roads often.

7.4.2 Do not use water, oil or other chemical solutions to clean your wheelchair. Be sure NOT to spray the vehicle with water, as not to

---

damage the electronic components and PCB circuit board.

7.4.3 Please clean the vehicle by wiping it with either a dry or moist cloth.

7.4.4 Please take the vehicle to an authorized KARMA wheelchair dealer for repairs and adjustments. Improper adjustments could lead to wheelchair malfunction or an accident.

7.4.5 Please use a soft and dry cloth to keep your wheelchair clean. Use moderate or mild detergent to clean the wheelchair, if necessary.



#### SUGGESTION

**Do not directly spray water on your wheelchair to wash it, as this could lead to a malfunction in the electric system.**

**Do not use gasoline, solvents or other abrasive solutions; the casing may become deformed or damaged.**



#### CAUTION

**Before performing any maintenance, be sure to turn the power OFF and unplug the charger if connected.**

**DO NOT over-tighten any hardware. This could cause damage to the frame and hardware.**



#### WARNING

**After ANY adjustments, repair or service and BEFORE use, make sure that all hardware is tightened securely, otherwise injury or damage may occur.**

### 7.5 Suggested Maintenance Procedures

7.5.1 Before using the powered wheelchair, make sure all nuts and bolts are tight.

7.5.2 Check all parts for damage or wear and have a qualified technician replace it if necessary.

7.5.3 Check all parts for proper adjustment.

7.5.4 Ensure that the batteries are properly maintained and charged as required.

7.5.5 Inspect brake for proper operation.

7.5.6 The wheels and tires should be checked periodically for cracks and wear, and should be replaced by a qualified technician.

- 
- 7.5.7 Regularly check for loose nuts and/or bolts in the front and rear wheels.  
If loose, have them adjusted by a qualified technician.
- 7.5.8 Clean dirt, dust and grease from exposed components.
- 7.5.9 A qualified technician can be found with an authorized distributor/  
dealer.

## 7.6 Transporting and Storing

- 7.6.1 Please refer to Section 5.3.7 Backrest Angle Adjustment to fold the  
backrest and detach the footrests.
- 7.6.2 Carry the body of the wheelchair by the front and back frame using two  
people. Do not lift the lower body by the casing or any detachable parts
- 7.6.3 Please store the wheelchair in a location where it is out of direct sunlight,  
rain and dew.
- 7.6.4 When stored for a long time, please charge the batteries to full and then  
disconnect the battery terminals. Please ask Karma dealer for the  
details.



### CAUTION

**When loading or moving the wheelchair in a vehicle, be sure that every part that have been detached from the wheelchair is placed properly to prevent them from moving. It could damage the vehicle or the wheelchair.**

**DO not detach any wiring or the steel wire.**

---

## 8. OPTIONAL ACCESSORIES

The available optional accessories may be modified. Please contact your dealer for more details.

### 8.1 Leon Sling Seat

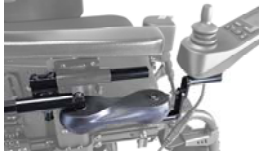

1. Parallel swing  
away controller



2. Hand Bar



3. Lighting

### 8.2 Leon Captain Seat



1. Hand Bar







2. Lighting

## 9. TROUBLESHOOTING

Trouble or Problems with Your Wheelchair

You can inspect the following before taking your wheelchair to a KARMA wheelchair dealer.











Problem	Checking Points and Corrective Action
My wheelchair does not start	Is the power turned OFF?  Turn ON the power.
	Do the batteries still have power? Is the battery indicator light not on?  Charge the batteries.
	Is the charger plugged into the wheelchair?  Unplug the charger and put it away.
	Is the seat release lever to be locked?  Unlocked the seat release lever.

If you cannot solve the problem by yourself, contact your KARMA wheelchair dealer for help.

### 9.1 VRII Controller, Battery & Diagnostics Indicator

The following table indicates what the gauge will display for any given state.

Indication	Status	Meaning	What to Do
•	1 signal	The battery needs charging or there is a bad connection to the	Check the connections to the battery. If the connections are good, try

Indication	Status	Meaning	What to Do
		battery.	charging the battery.
	2 signals	The left hand motor has a bad connection.	Check the connections to the left hand motor.
	3 signals	The left hand motor has a short circuit to a battery connection.	Connect your service agent.
	4 signals	The right hand motor has a bad connection.	Check the connections to the left hand motor.
	5 signals	The left hand motor has a short circuit to a battery connection.	Connect your service agent.
	6 signals	The wheelchair is being prevented from driving by an external signal.	Please remove the charger.
	7 signals	A joystick fault is indicated.	Make sure that the joystick is in the center position.
	8 signals	A joystick fault is indicated.	Make sure that all connections are secure.
	9 signals	The parking brakes have a bad connection.	Check the parking brake and motor connections and make sure all connections are secure.
	10 signals	An excessive voltage has been applied to the control system.	Check the battery connections.
	7 signals + S	A communication fault is indicated.	Make sure that joystick cable is securely connected and not damaged
	8 signals + A	An actuator trip is indicated.	If more than one actuator is fitted check which actuator is not working correctly. Check the actuator wiring.

9.1.1 Please paste the stickers on the controller panel according to the tables

listed below.

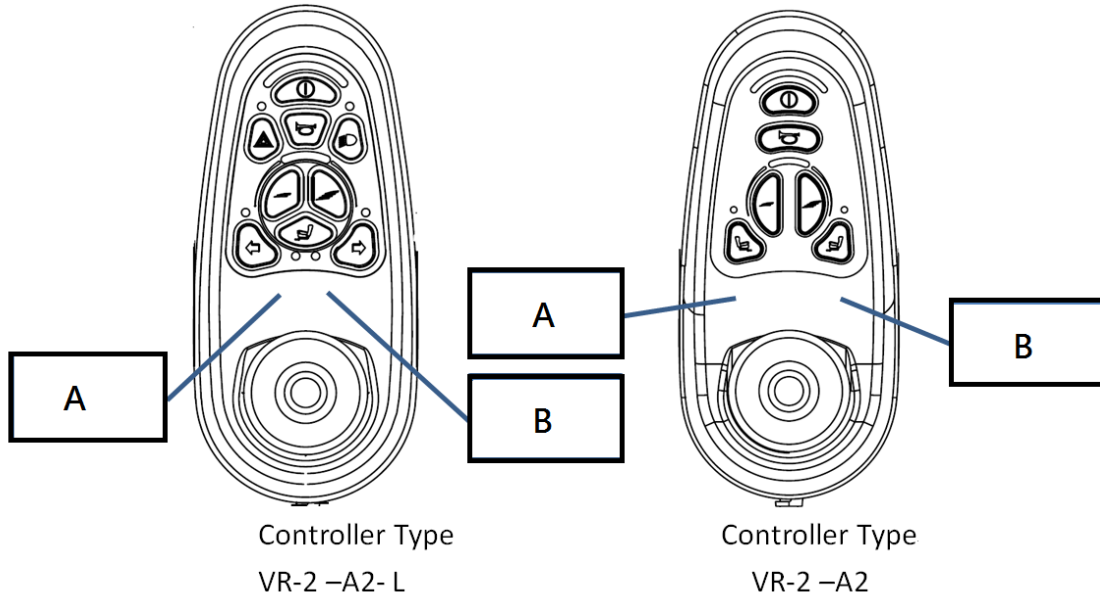

Seat Type	Location A	Location B	Seat Type	Location A	Location B
SL- TR			KS-T		
SL-T			KS-LT		
SL-R			KS-TR		
			KS-R		

# 10. SPECIFICATIONS

(±1 cm ±0.5 kg)

Description	Model		Sling Seat(with pelvic belt)		Captain Seat(with pelvic belt)	
	Seat Width	430mm(17" )	480mm(19" )	460mm(18" )	510mm(20" )	
Seat Depth	410/430/460mm(16/17/18inch)		430mm(17" )	480mm(19" )		
Front Seat Height	550mm(w/cushion)		530mm	510mm		
Backrest Height	430mm		530mm	480mm		
Seat Angle	2° / 5°		12°	9°		
Back Angle	-1° ~11°		0°~65°	0°~45°		
Armrest Height	180mm ~280mm (the range of adjustable height is 100mm )		210mm~310mm			
Leg rest Length	390mm ~510mm		390mm~520mm			
Manual/Powered Recline	Tilt,	Powered Tilt: 5°~23° Optional Powered Recline: 0°~32°	Manual Tilt : 0°~65°	Manual Tilt : 0°~45°		
Suspension	4 shock absorber					
Motor(Nominal Output)	DC 450W/4P					
Batteries	50Ah * 2pcs (option 80A*2pcs)					
Controller	VR2					
Caster Wheel(inch)	230mm(9" )// Pneumatic Tire					
Rear Wheel(inch)	355mm(14" )// Pneumatic Tire					
Max. Safe Slope	8°					
Max. Speed	12km/hr					
Range (km)	30km(45km by using 80A batteries)					
Maximum Climbing Ability	Obstacle		50mm			
Turning Radius	780mm					
Overall Length * Width* Height	1060mm *620mm *1300mm (with the headrest)		1060mm *620mm*1230mm( with the headrest))			
Max. User Weight	140 kg					
Weight (W/O Batteries)	78 kg		70kg			
Total Weight(W/ Batteries)	108 kg		100 kg			

Model	KISS Seat (adult)	KISS Seat (pediatric)
Description		
Seat Width	410mm~510mm	310mm~410mm
Seat Depth	410mm~510mm	310mm~410mm
Front Seat Height	400mm~515mm( manual) / 460mm~540mm(manual, with tilting option) / 485mm~785mm(powered, with lifting and tilting options)	
Backrest Height	510mm~560mm	410mm~460mm
Seat Angle	0°~6° , three settings for incremental adjustments in increments of 3°. / -6°~6° , four settings for incremental adjustments in increments of 3°. (with tilting option) / Not adjustable ( with lifting and tilting options)	
Back Angle	0°~30°(Manual) / 0°~80°(Powered)	
Armrest Height	200mm~300mm	150mm~250mm
Leg rest Length	330mm~480mm	240mm~350mm
Manual/Powered Tilt	Tilt : 0°~45°(with tilting option) / Tilt : 0°~45°(with lifting and tilting options)	
Suspension	4 shock absorber	
Motor(Nominal Output)	DC 24V 450W	
Batteries	50Ah * 2pcs / 80Ah * 2pcs (optional)	
Controller	VR2 or R-net	
Caster Wheel	230mm (9") )Pneumatic Tire ( optional PU tire)	
Rear Wheel	355mm(14") Pneumatic Tire 14"(optional PU tire)	
Max Safe Slope	6°	
Max. Speed	10 km / hr	
Range (km)	25 km	
Maximum Obstacle Climbing Ability	50mm	
Turning Radius	900mm	850mm
Overall Length(w/wt legrest) * Width* Height(w/wt headsupport)	1080/850mm*650mm*1215/1295mm / 1080/850mm*650mm*1215/1295mm (with tilting option)/ 1080/850mm*650mm*1240/1540mm (with lifting and tilting options)	960/850mm*650mm*1095/1175m m/ 960/850mm*650mm*1095/1175m m(with tilting option)/ 960/850mm*650mm*1120/1420m m(with lifting and tilting options)
Max. User Weight	140 kg	100 kg
Weight (W/O Batteries)	109/106kg (without batteries) / 116/113kg (without batteries, with tilting option) / 133/130kg (without batteries, with lifting and tilting options )	

## 10.1 The Leon Series Static Stability

-The degree tolerance is +0, -1 degree.

-The test condition: size of test dummy used: 140 kg

Test Requirement		Leon Sling Seat		Leon Captain Seat	
		Min.	Max.	Min.	Max.
Static Stability Downhill		9.5°		>14.5°	>14.5°
Static Stability Uphill	With Locked Rear Wheels	9.5°		11.3°	>15.5°
	With Un-Locked Rear Wheels	9.5°		15.8°	>21.7°
Static Stability Sideway		9.5°		18.5°	19.2°

The Leon Series is equipped with powered tilt seatrest function.

※Range (the maximum driving distance per complete charge)/ is estimated based on the following conditions: 20°C(68°F), an 80 kg driver, brand new fully charged batteries and a constant driving speed of 10 km/hr .

Karma's Quality Control team sets the parameters of your central relay box (controller) for optimum performance within the regulations of EN-12184.

These parameters were double checked by the QC team before your scooter left our factory

These parameters may be changed to suit certain individuals' specific needs and requirements. If you need the parameters changed, please contact your dealer who will put you in contact with our agent. They will know how to use the programmer properly to "dial in" your scooter for your optimum usage. The programmer's effect on the performance quality can be seen in the above chart



### CAUTION

**Always keep the backrest of your seat in an upright position before driving up a slope. That is, when the backrest is tilted, do not drive it on a slope.**

**Avoid turning suddenly and never try to climb and descend a ramp diagonally**

---

## 11. CLEANING & RECYCLING

### 11.1 Cleaning

- 11.1.1 In order to lengthen the life of your wheelchair, it is suggested that you clean the wheelchair periodically (if not daily), especially after using it in the rain or snow.
- 11.1.2 We suggest that you don't use your wheelchair in the rain or snow.
- 11.1.3 If you are traveling and get caught in the rain, we suggest you try to find a shelter and turn OFF your wheelchair while waiting it out.
- 11.1.4 If you can't find shelter, proceed to your destination. However, we do not recommend you do this often as it may shorten the life of your wheelchair or cause damage.
- 11.1.5 Driver's seat upholstery: use soapy water. Wring out the sponge/cloth before scrubbing. Do not use the wheelchair until it is dry.
- 11.1.6 Frame: wipe with a damp cloth, but be sure not to splash/spray the wheelchair with water, as doing so may damage the motor, electrical wiring and battery.
- 11.1.7 If compressed air is available, you can use the compressed air to clean your wheelchair (do not exceed 7K and keep the nozzle at least 10 cm away from your wheelchair).
- 11.1.8 Casing: wipe with a damp cloth. After it is dry, coat the casing with a light layer of wax, if desired.

---

## 11.2 Post-Consumer Recycling

11.2.1 A post-consumer recycling plan should follow the Environmental Protection Administration's regulations.

11.2.2 The items listed below are for reference only as local law and regulation may vary.

Material	Part Name	Method
Aluminum-alloy	Frame	Recyclable
ABS	Various	Recyclable
Various	Battery	Recyclable
Various	Motor/Reduction Gear	Recyclable
Various	Electric Parts	Recyclable

11.2.3 There are many organizations in many countries you can find on the internet that will accept used goods for charity or disassemble electronic equipment and batteries to recycle them.

11.2.4 Please search the information highway to help less fortunate individuals and protect our planet for future generations.

11.2.5 If you do not have access to the world wide web please use your local phone directory, ask for operator assistance or go to your local government center for more information.

11.2.6 Various parts of this wheelchair should be recycled to the collection and recycling location nearest to you. Earth Day is every day.

Check with your local recycling center on where and how to recycle used batteries as this information varies from region to region.	
---	--

## 12. WARRANTY

### 12.1 Serial Number

To ensure after-sale service and warranty, please record and fill in the vehicle identification number. The serial number can be found on the steering column below the control panel.

---

Model	
Serial Number	

## 12.2 Contents of Warranty

12.2.1 Repair will be provided free of charge if the problems are due to manufacturing or defective components within the warranty period (a repair of this kind will hereafter be called warranty repair).

12.2.2 The warranty repair can be performed by authorized KARMA wheelchair dealers only.

12.2.3 KARMA is not responsible for the transportation costs for repair and replacement.

12.2.4 Replaced parts will be the property of KARMA.

## 12.3 Warranty Duration and Parts Covered by the Warranty

Please contact your local dealer.

## 12.4 Items Not Covered

The items listed below are not covered:

12.4.1 Consumable parts such as brake shoes or pads, clutch shoe and lining, light bulbs, fuses, upholstery and seating, brake cable, oil seal packing and gasket, screws/bolts and washers, lubricant oil and grease, carbon brush inside the motor, battery liquid, footrest carpet, et cetera;

12.4.2 Those that do not affect the quality and functioning of the wheelchair such as noise or vibration;

12.4.3 Wear and tear resulting from usage as well as conditions resulting from lapse of time (e.g., normal aging and deterioration of paint, electroplating, plastic parts, etc);

12.4.4 Damage due to a lack of maintenance or improper operation and storage;

12.4.5 Fees for routine inspections, adjustments, adding oil, cleaning and other maintenance;

12.4.6 Fees for regular inspections and maintenance; and

12.4.7 Any fees incurred as a result of warranty repair, loss or compensation

---

because of the unavailability of the wheelchair (telephone use, shipping, car rental, travel costs, et cetera).

## **12.5 Problems Not Covered**

Problems caused by the following reasons are not covered:

- 12.5.1 Failure to carry out the regular inspection and maintenance recommended by this owner's manual;
- 12.5.2 Improper storage;
- 12.5.3 Tampering by changing or adding components to the vehicle, which are not approved by KARMA;
- 12.5.4 Damage caused by using non-KARMA genuine parts or other parts not recommended by KARMA;
- 12.5.5 Abuse or misuse of the vehicle such as driving over curbs and overloading the wheelchair with passengers or goods;
- 12.5.6 Driving in places where the vehicle should not normally be driven or used;
- 12.5.7 Damage or surface corrosion from environmental factors such as airborne fallout (chemicals, tree sap, et cetera), stones, hail, windstorms, lightning, floods and so on;
- 12.5.8 Change of any material or component parts not authorized by KARMA (Don't carry objects that may lead to the wheelchair being unbalanced) ;
- 12.5.9 The wheelchair shall not be pulled or pushed by another vehicle when there is a person on the wheelchair or the rear wheels are not set to the freewheel mode; and having its structure inspected.
- 12.5.10 Do not drive a wheelchair that is older than 10 years without having its structure inspected.

## **12.6 The Responsibilities of the User**

The following items are the responsibility of the user:

- 12.6.1 Proper use of the vehicle in accordance with this Owner's Manual;
  - 12.6.2 Performance of the daily inspections;
  - 12.6.3 Performance of the regular maintenance recommended by KARMA;
- and

---

12.6.4 Keep a record of vehicle inspection and maintenance in the back of this Owner's Manual.

## 12.7 Warranty Effectiveness

The warranty form must be completely filled out and stamped by the KARMA dealership where the wheelchair was purchased.

## 12.8 Transfer of Warranty Rights

If you purchase a second-hand KARMA wheelchair while it is still with in the warranty period, bring the Owner's Manual and the vehicle to the dealership where the wheelchair was purchased for registration.

Warranty Form (You may photocopy this from)

<b>Full Name:</b>	
<b>Gender:</b>	
<b>Date of Birth:</b>	
<b>Address:</b>	
<b>Model:</b>	
<b>Serial Number:</b>	
<b>Date of Purchase:</b>	

Dealer's Data

<b>Name of the Store:</b>	
<b>Phone Number and Address:</b>	

If you have any suggestions on how to improve our products, please don't hesitate contacting your local dealer to let us know what you think of your wheelchair. Thank you and enjoy.

# karma

National agent:

Sold and serviced by:

**KARMA MEDICAL PRODUCTS CO., LTD.**

[Http://www.KarmaMedical.com](http://www.KarmaMedical.com)

E-mail:[globalsales@karma.com.tw](mailto:globalsales@karma.com.tw)

KARMA reserves the right to modify information herein without further notice.