

Applies to the following models:

Likorall 242 S	Prod. no. 3122009-3122010
Likorall 242 ES	Prod. no. 3122005-3122006
Likorall 242 S R2R	Prod. no. 3122011-3122012
Likorall 242 ES R2R	Prod. no. 3122007-3122008
Likorall 243 ES	Prod. no. 3123001-3123002
Likorall 250 ES	Prod. no. 3122501-3122502
Likorall 250 S, IRC	Prod. no. 3124050

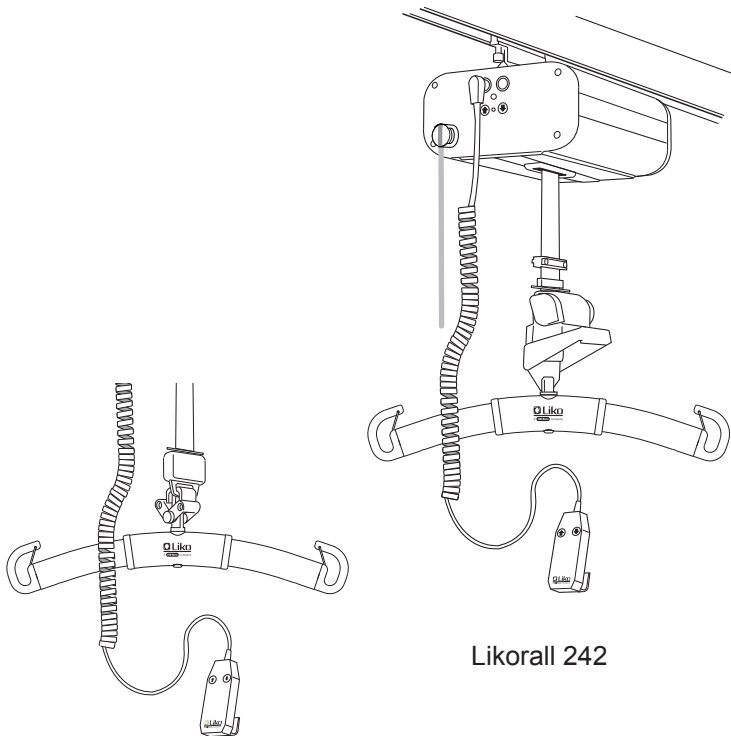

Likorall 242

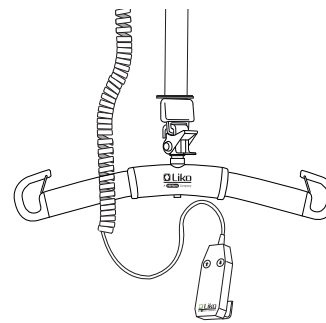

Likorall 243, 250

Likorall 242 R2R

Product Description

Likorall is one of the world's most popular overhead lift motors. Likorall is designed and developed for Liko's complete range of fixed installed and free-standing lift systems. A Liko lift system is always close at hand and easy to use.

All common lifts and transfers can be performed using Likorall, for instance between bed/wheelchair, to/ from floor, toilet visits, gait training, and together with stretchers.

Likorall R2R (room to room) enables the patient to be moved between two rail systems in separate rooms, without connecting rails and without making holes over doors.

Likorall with the ES designation is prepared for operation with the wireless HandControl Remote (IR) and in addition, a Transfer Motor can be connected for motor driven movement of Likorall ES along the rail. Likorall S, IRC is prepared for continuous charging through the railsystem by Liko's In-Rail charging system (IRC)

Accessories

A large and complete range of accessories are available for Likorall, including many different sling models in several sizes and designs.

In this document, the person being lifted is referred to as the patient, and the person helping is referred to as the caregiver.

△ is a warning triangle used for situations which require extra care and attention.

IMPORTANT!

Read the instruction guide for both the patient lift and lifting accessories before use. Lifting and transferring a person always involves a certain level of risk. It is important to completely understand the contents of the instruction guides. The equipment should be used only by trained personnel. Please contact your Liko/Hill-Rom representative in the event of any uncertainties or questions.

Table of Contents

Safety Instructions	2
Definitions	3
Technical Data	3
Measurements.....	4
Assembly.....	4
Operation.....	4
Charging the Batteries	7
Transferring from room to room.....	8
Maximum Load.....	9
Recommended Lifting Accessories	9
Simple Troubleshooting.....	11
Inspection and Maintenance.....	12

NOTE!

This instruction guide contains important information for users of the product. All those who use the product should review and fully understand the contents of the instruction guide. Remember to keep the instruction guide in a place where it is always available to those using the product.

Safety Instructions

△ Installation of Likorall to rail carriages must to be made by personnel authorized by Liko and in accordance with the current installation instructions.

Before using the first time make sure that:

- the lifting accessories are properly attached to the lift
- the batteries have been charged for at least 8 hours
- you have read the instruction guide for the lift and lifting accessories
- personnel using the lift are informed of the correct use of the lift and lifting accessories
- the lifting accessory is selected appropriately, in terms of type, size, material and design with regard to the patient's needs.

Before lifting, always ensure that:

- the lift strap is not twisted or worn and can move in and out of the lift freely
- the lifting accessories are not damaged
- the lifting accessory is correctly and securely applied to the patient in order to prevent injuries
- the lifting accessories are properly attached to the lift
- the lifting accessories hang vertically and can move freely
- the sling bar latches are intact; missing or damaged latches must always be replaced
- the sling's strap loops are correctly connected to the sling bar hooks when the sling straps are extended, but before the patient is lifted from the underlying surface.

△ Never leave a patient unattended during a lifting situation!



Likorall have been tested by accredited testing institutes and comply with the requirements for MDD Class 1 products (MDD 93/42/EEC).

Likorall complies with the requirements in EN ISO 10535:2006, IEC 60601-1, IEC 60601-1-2, ANSI/AAMI ES60601-1 and CAN/CSA C22.2 no 60601-1.

△ Under no circumstances must the lift be modified. If you have any questions, please contact Liko/Hill-Rom.

Particular care must be observed when using strong sources of electromagnetic disturbance, such as diathermy, etc, so that diathermy cables are not positioned on or near the lift. If you have questions, please consult the responsible assistive-device technician or the supplier.

The lift may not be used in areas where flammable mixtures may occur, for example in areas where flammable goods are stored.

Definitions

Likorall

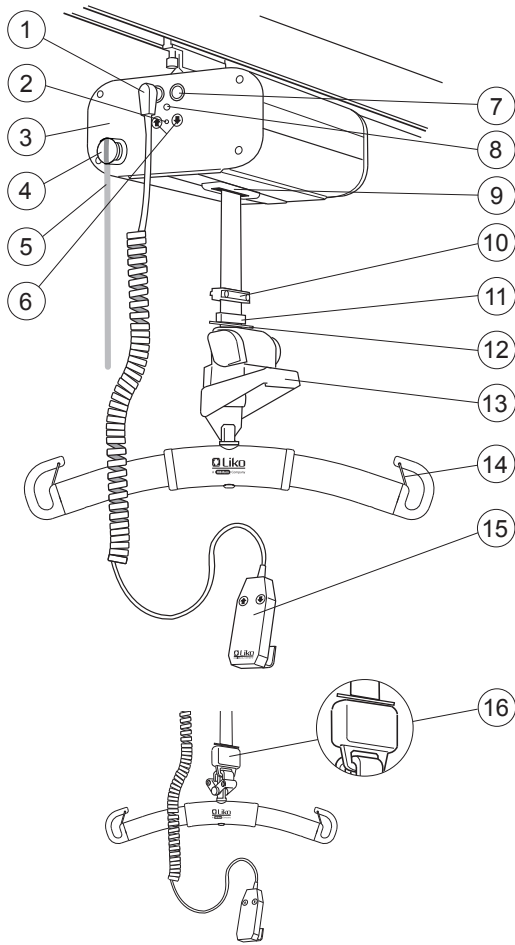

1. Connection: hand control
2. Indication: charging
3. End cover
4. Emergency stop
5. Emergency stop cord
6. Emergency lowering/raising (electrical)
7. Outlet for transfer motor/contact rail (exclusively: ES)
8. IR receiver (exclusively: ES)
9. SSP Limit Switch
10. Strap stop (exclusively: Likorall 242)
11. Movable strap stop (exclusively: *Likorall 242*)
12. Hang-up, HandControl Hanger
13. Mechanical emergency lowering (exclusively: *Likorall 242*)
14. Latches
15. Hand control with wire
16. Q-link (not at *Likorall 242*)

Technical Data

Maximum load: Likorall 242: 200 kg (440 lbs)
Likorall 243: 230 kg (507 lbs)
Likorall 250: 250 kg (550 lbs)

Batteries: 2 x 12 V 2.6 Ah. Valve-regulated lead-acid gel-type batteries. New batteries are provided by the supplier.

Battery charger: *SMP CC-10-43-24*; 100-240 V AC, 40-60 Hz, max 600 mA
IRC (In-Rail Charging): CH01 FW7218M/24; 100-240 V AC, 50-60 Hz, max 500 mA

Lifting speed: 50 mm/s (2 inch./s)

Lifting interval: 2050 mm (80.7 inch.)
(242 vertically adjustable)

Electrical data: 24 V, 12 A

Lift motor weight: Likorall 242 13.0 kg (28.6 lbs)
Likorall 242 R2R 13.2 kg (29 lbs)
Likorall 243 12.6 kg (27.7 lbs)
Likorall 250 12.6 kg (27.7 lbs)

Emergency lowering device: Mechanical: Likorall 242
Electrical: Likorall 242 R2R
Likorall 243
Likorall 250

Intermittent operation: Int. Op 10/90, active operation max 0.5 min.

Sound level: 49 dB

Protection class: IP 43

Protection class hand control: IP 43

Operating forces of controls: 5 N

 Intended for indoor use.

 Type B, in accordance with the electrical shock protection class.

Likorall is equipped with a SFS (Single Fault Safety) safety drum. This patented safety design provides protection against uncontrolled lowering. The lift strap has a tenfold safety.

Measurements

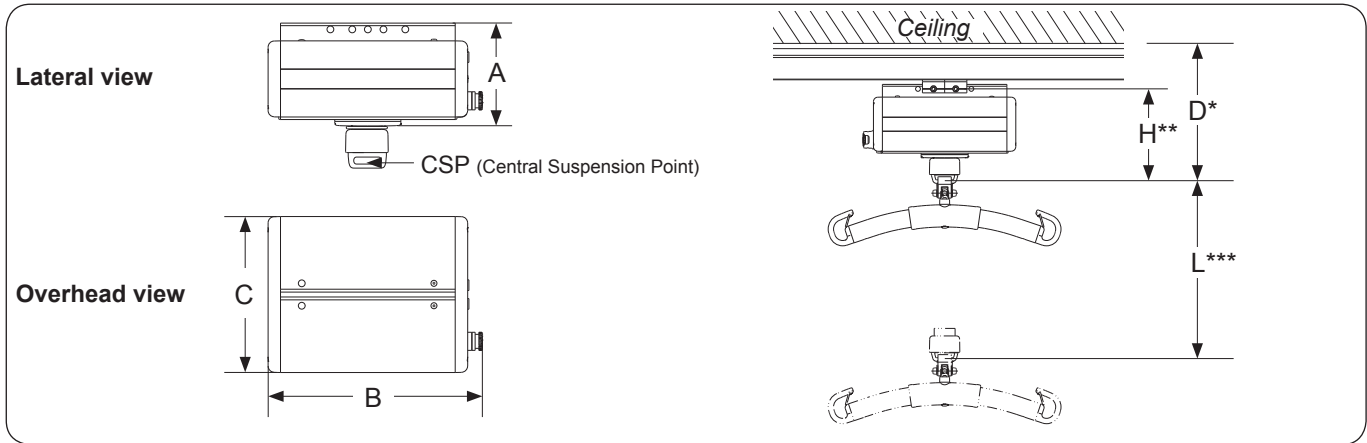

Measurements in mm.

A	B	C	D*	H**		L***
165	340	250	293	210 (models: 242 R2R, 243, 250)		2050
				335 (models: 242)		

Measurements in inch.

A	B	C	D*	H**		L***
6.49	13.38	9.84	11.53	8.67 (models: 242 R2R, 243, 250)		80.7
				13.18 (models: 242)		

* Minimum distance from ceiling to CSP at maximum lifting height.

** Built-in dimension: the distance between the attachment point for the lift unit on the carriage and the CSP at maximum lifting height.

*** Lifting interval: the distance between maximum lifting height and minimum lifting height measured in CSP.

Assembly

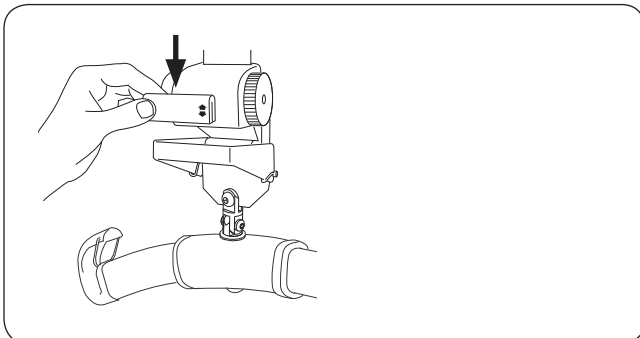

Handle reinforcement (exclusively: Likorall 242 S, ES)
Press the reinforcement (included in the bag containing the instruction guide) labelled "Emergency lowering" onto the emergency lowering handle.

Operation

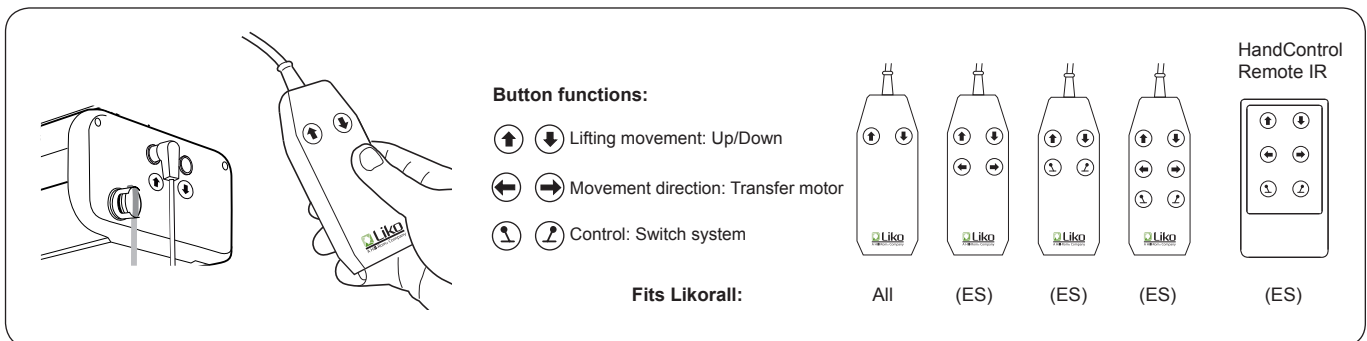

Hand Control Likorall

Likorall is operated with a light push on the buttons of the hand control. The arrow directions should be the same as the direction shown in the illustration. The movement ceases when the button is released. For the Likorall ES, there is a number of hand controls to choose from, depending on how the lift and rail system are equipped, and an IR hand control for wireless operation.

If needed, the lifting motion can also be controlled without hand control via the buttons ⬇️ and ⬆️ respectively, on the end cover of the lift, see page 6.

Activate:

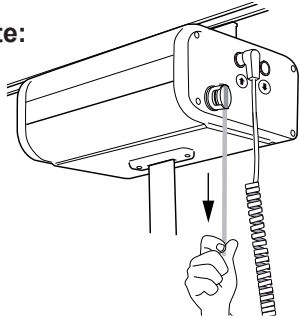

Reset:

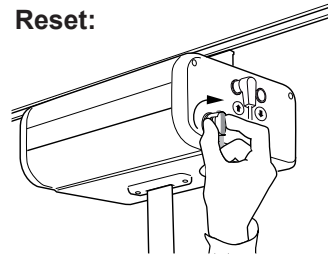

Emergency stop

For emergency stop: pull the red emergency stop cord.

To reset: turn the button in the direction of the arrows.

The red cord on the lift motor's end cover is intended for use if an emergency situation occurs.

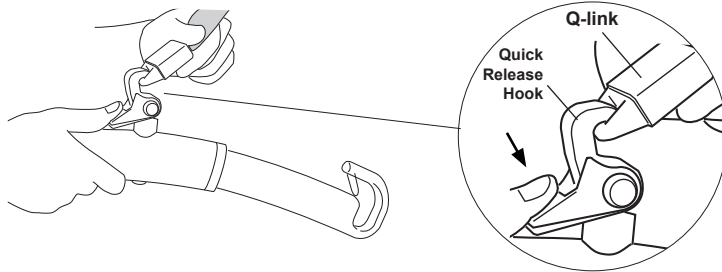

Lifting accessory with quick-release hook (Likorall: 242 R2R, 243 ES, 250 ES)

Push down the red catch and connect the quick-release hook to the Q-link. Release and check that the catch locks in order to prevent involuntary unhooking from the Q-link. Read more about Liko's Quick-release Hook system on page 9.

1.

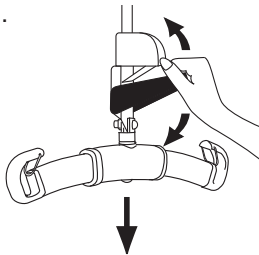

2.

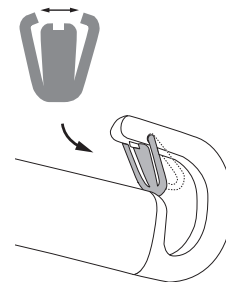
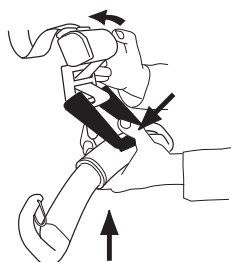

Mechanical emergency lowering (Likorall 242 S/ ES)

- 1) Move the emergency lowering handle up and down until the patient has been lowered and the lift strap is completely slack. Always ensure that the emergency lowering is made to a bed, wheelchair or other suitable location.
- 2) After mechanical emergency lowering has been performed, resetting/adjustment of the lifting height is required:
 - Lower the sling bar so that the lift strap is completely slack.
 - Hold down the emergency lowering handle halfway. Simultaneously, tighten the lift strap by turning the black wheel counter clockwise with the other hand. Repeat until the desired height has been achieved.

Installation of Latches

After installation, check that the latch locks and runs freely in the sling bar hook.

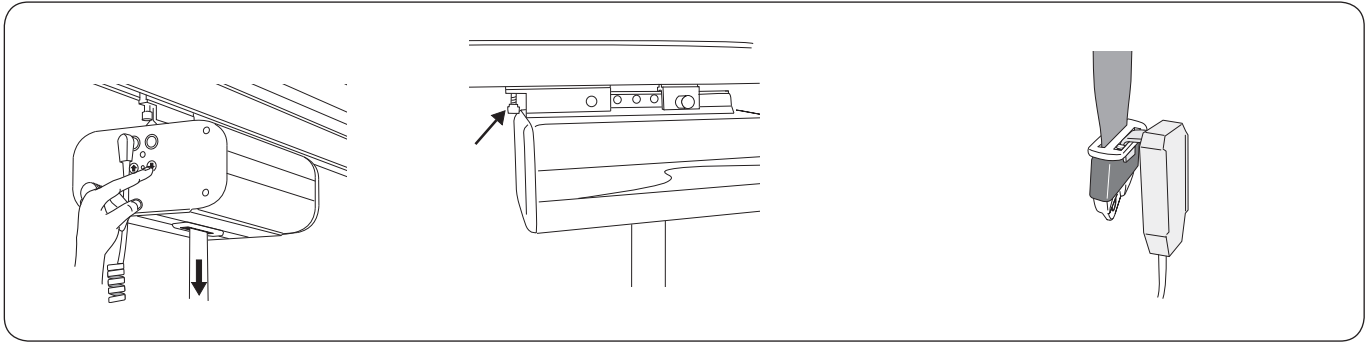

Electrical emergency lowering

Emergency lower by pushing in the button on the end cover of the lift. Always ensure that the emergency lowering is made to a bed, wheelchair or other suitable location.

Carriages with adjustable friction brake

The amount of drag along the rail can be adjusted on carriages equipped with a friction brake. Turn the brake clockwise for increased resistance and counter clockwise to reduce resistance.

The following carriages have a friction brake: prod. no. 3126011 and 3126015.

Hang-up HandControl Hanger

When not in use, the hand control can be hung on the Hang-up Hand control hanger.

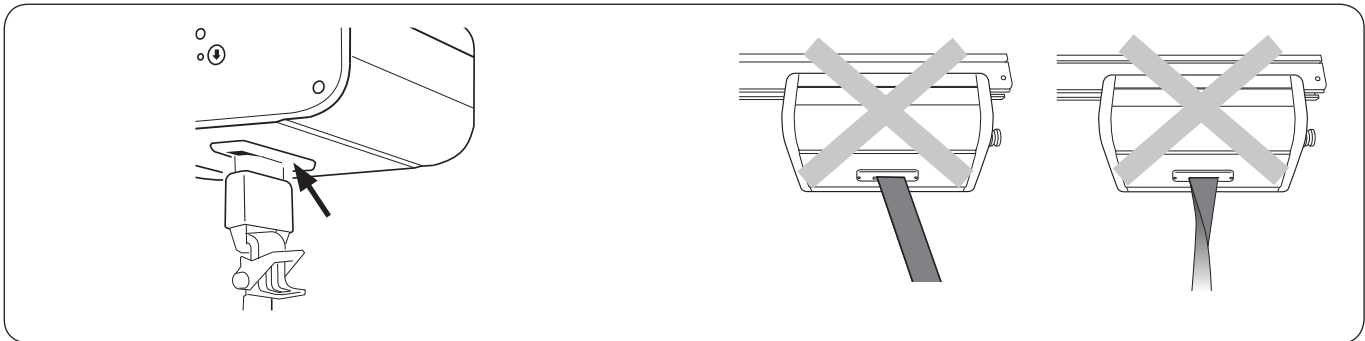

SSP Limit Switch

The lifting motion is stopped electrically with a light touch on the SSP Limit Switch from, for instance, the strap stops, Q-link or if the lift strap is subjected to harmful strain, for example, if it is pulled sideways or folded over during the lifting motion. If the SSP Limit Switch is activated so that the lifting motion stops, the lift can once again be operated after the lift strap is straight again (a short delay in the lifting motion is normal in these cases). The SSP Limit Switch protects the lift motor from mechanical strain and it also prevents squeeze injury.

△ Ensure that the lift strap is kept straight and stretched when it runs in and out of the lift motor.



Indication: charging

Likorall indicates in two ways that the battery needs charging:

- Buzzer: sounds when lifting
- LED, : flashes (red) when lifting

When either of these signals sounds or illuminates, the lift should be charged as soon as possible. See Charging the batteries, page 7.

△ Never move the lift by pulling the hand control!

Charging the Batteries

In order to ensure maximum battery life, it is important to charge the batteries regularly. We recommend that you charge the batteries after use or every night. Full charge is achieved after max. 8 hours. Fully charged batteries will last for approximately 60 lift cycles.

The lift cannot be charged with the emergency stop engaged.

NOTE! If the lift will not be used for a longer period of time, a charging system should be activated to allow the battery to charge or the emergency stop button should be pressed in order to prevent the battery from discharging.

△ Likorall has several charging systems, these systems must never be activated parallelly.

Charging via hand control

1. Check that the emergency stop button is not pressed.
2. Place the hand control in the charger's socket.
3. Connect the charger to a 100-240 V AC electric socket.
4. A green LED illuminates to indicate that the charger is connected to the electrical grid.
5. The charging starts automatically, and a yellow LED indicates that the batteries are charging.
6. When the battery is fully charged, the charger shuts off automatically and the yellow LED turns off.

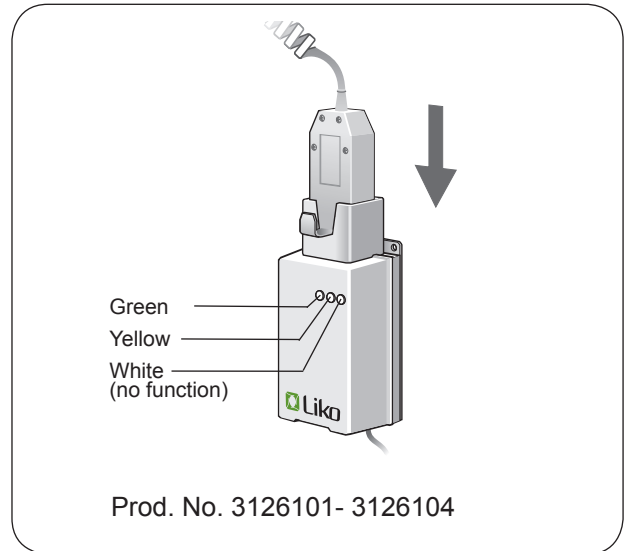

Alternative charging procedure

In-Rail Charging

Liko's In-Rail Charging system is an easy to use charging system. When using the In-Rail Charging system the lift will charge continuously. During active lifting the In-Rail Charging system will "pause" and re-activate charging automatically after completed operation.

Indications from IRC:

- A green LED-light on the lift indicate that the lift is ready to use.
- A yellow LED-light on the lift indicate that the lift has low battery capacity, contact Liko if the problem persist.

For more information, please contact your Liko representative or visit our website www.liko.com.

MultiStation

As an alternative to charging via the hand control, the batteries can be charged with a MultiStation installed on the rail system. In this case, Likorall must be equipped with a contact rail or a transfer motor. The Likorall batteries are then charged by parking the lift in the charging position under the MultiStation (see figure).

This charging procedure is also suitable when Likorall is operated by HandControl IR.

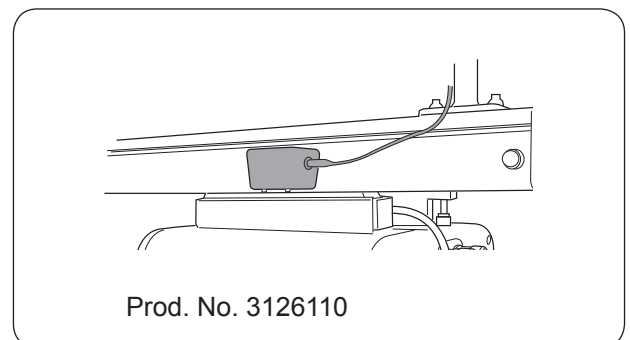

Likorall comply with the Directive 2002/96/EC on waste electrical and electronic equipment. Old batteries are to be deposited at the nearest recycling facility in accordance with local regulations or given to personnel authorized by Liko/Hill-Rom.

Transferring from room to room

Liko's R2R Room-to-Room system is an effective solution for safe and easy transfer of patients between two or more rooms. The R2R system is mounted without making openings in walls over doors and full isolation is therefore retained between the rooms supported by the system.

The transfer is performed in a safe and easy manner, with the aid of separate rail systems for each room. Liko's R2R system enables linking together two Likorall when transferring from room to room. The actual transfer operation between two rooms is performed with a comfortable transition for the patient from one Likorall to another.

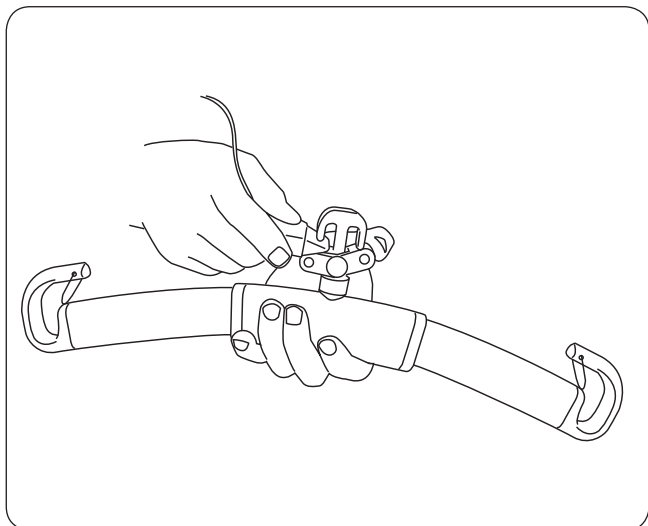

Mounting Universal SlingBar R2R (Room-to-Room)

The Universal SlingBar R2R has a double hook with Quick-release. The double hook has protection against unintentional detachment.

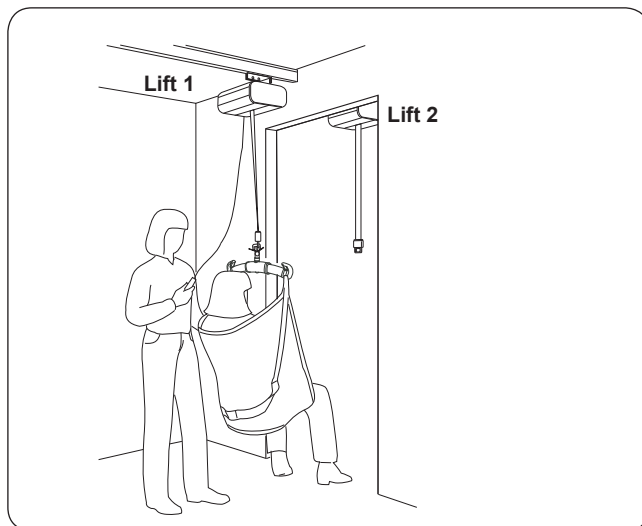

1. Move Lift 1 with the patient as close to the door way as possible. Lower the lift as far as possible, bearing in mind the patient's comfort.

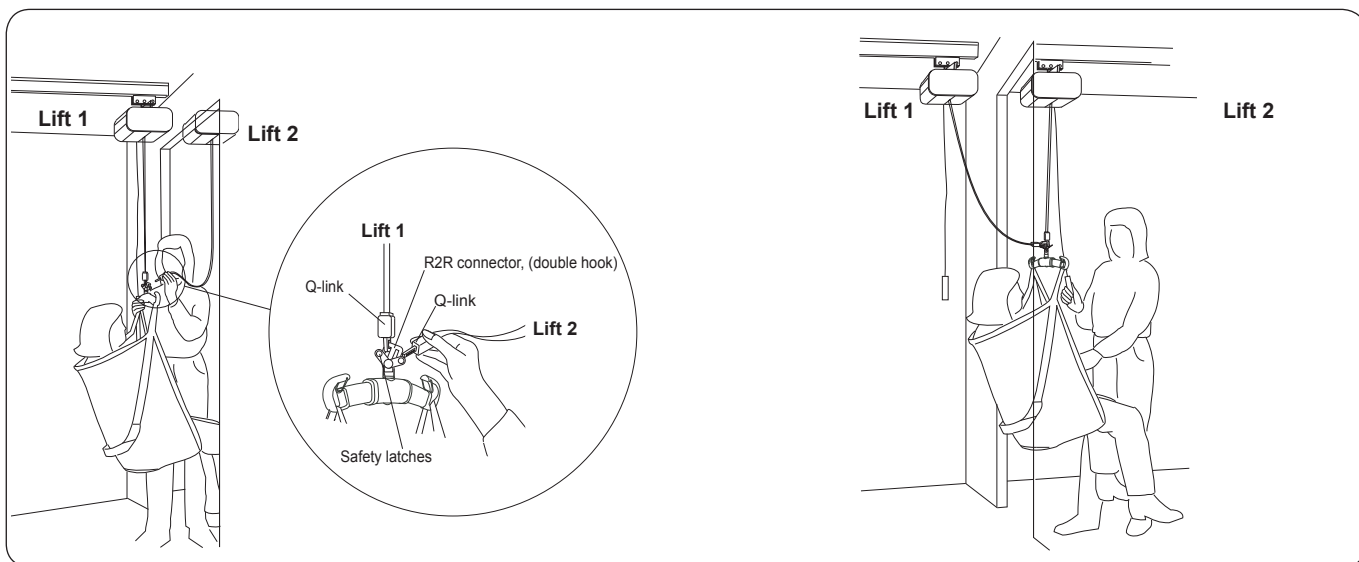

2. Move Lift 2 as close to the door opening as possible. Lower the lift strap from Lift 2 a sufficient length and connect the Q-link to the Universal SlingBar R2R. Check that the safety latches on the R2R connector function properly.

3. Raise Lift 2. The patient is successively moved to the next room and finally suspended in Lift 2 only. When the pressure is relieved from the lift strap for Lift 1, disconnect the lift strap from the Universal SlingBar R2R and the transfer can be carried out in the next room.

NOTE! To free the Q-link from the Universal SlingBar R2R, it may be necessary to let out additional strap from Lift 1.

Maximum Load

Different maximum loads may apply to different products on the assembled lift system: lift, sling bar, sling and any other accessories used. For the assembled lift system, the maximum load is always the lowest maximum load rating for any of the components. For example, a LikoRall which is approved for 200 kg (440 lbs) can be equipped with a sling bar which is approved for 300 kg (660 lbs). In this case, the maximum load of 200 kg (440 lbs) applies to the assembled lift system. Study the markings on the lift and lifting accessories or contact your Liko/Hill-Rom representative if you have any questions.

Recommended Lifting Accessories

△ Using lifting accessories other than those approved can entail a risk.

The Liko assortment contains many sling bars, slings, stretchers, scales and other accessories to solve most lifting needs. Below is a list of lifting accessories suitable for LikoRall.

To select suitable slings and other lifting accessories, please see the "Lifting accessories" brochure. For additional guidance in selecting a sling, study the instruction guide for the respective sling models. Here you will also find guidance for combining Liko's sling bars with Liko's slings.

Contact your Liko/Hill-Rom representative or visit www.liko.com for advice and information on Liko's product range.

SlingBar Mini 220

Max. load 205 kg (450 lbs)

Prod. no. 3156005

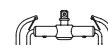

Universal SlingBar 350 with Quick-release Hook™

Fixed connection, prod. no. 3156074*

Max. load 300 kg (660 lbs)

Prod. no. 3156084



Universal SlingBar 450 with Quick-release Hook™

Fixed connection, prod. no. 3156075*

Max. load 300 kg (660 lbs)

Prod. no. 3156085



Universal SlingBar 600 with Quick-release Hook™

Fixed connection, prod. no. 3156076*

Max. load 300 kg (660 lbs)

Prod. no. 3156086

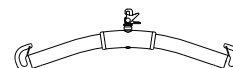

Universal SlingBar 670 Twin with Quick-release Hook™

Fixed connection, prod. no. 3156077*

Max. load 300 kg (660 lbs)

Prod. no. 3156087

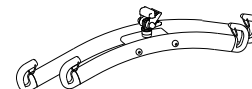

Universal SideBars 450 including bag

Max. load 300 kg (660 lbs)

Prod. no. 3156079

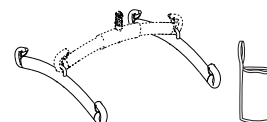

Sling Cross-bar 450 with Quick-release Hook™

Fixed connection, prod. no. 3156021*

Max. load 300 kg (660 lbs)

Prod. no. 3156022

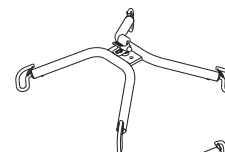

Sling Cross-bar 670 with Quick-release Hook™

Fixed connection, prod. no. 3156018*

Max. load 300 kg (660 lbs)

Prod. no. 3156019

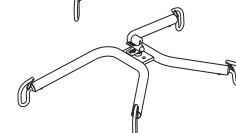

* Sling bars with fixed connection can be equipped with Quick-release Hook

Quick-Release Hook

Liko's Quick-release Hooks are a system for quick change of lifting accessories on Liko's mobile and stationary lifts equipped with the Q-link. The Quick-release Hook can be installed on lifting accessories with a fixed connection.

The Quick-release Hook Universal fits the Universal SlingBar 350, 450 and 600 (prod. no. 3156074 - 3156076). Quick-release Hook TDM fits the SlingBar Mini 220 (prod. no. 3156005), Sling Cross-bar 450 and 670 (prod. no. 3156021 and 3156018) and Universal TwinBar 670 (prod. no. 3156077).

See the "Guide to Liko's Quick-release Hook System", which can be downloaded from our website www.liko.com, or contact Liko/Hill-Rom for more information about the advantages and uses of the Quick-release Hook system.

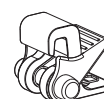

Quick-Release Hook Universal
Prod. No. 3156508



Quick-Release Hook TDM
Prod. No. 3156502



Stretcher

All stretchers in Liko's product range can be used with Likorall.
Contact Liko/Hill-Rom for further information.

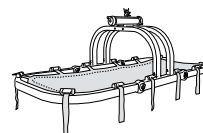

Scale

For weighing persons in combination with the Likorall,
we recommend LikoScale 350. This can easily be installed
with the LikoScale Adapter Kit.
Please contact Liko/Hill-Rom for more information

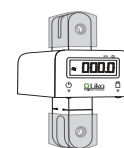

LikoScale 350
Prod. No. 3156228

Liko Support Springs for bounce and gait training

Is used in order to produce a softer, springy motion during gait training. The springs are available in two sizes: short prod. no. 3156512 and long prod. no. 3156511. These springs are intended for patient weights up to 70 kg (154 lbs). For patient weights up to 100 kg (220 lbs): prod. no. 3156513 (short). Also see the instruction guide for Liko MasterVest, models 60 and 64 or Liko LiftPants model 92, for more information.

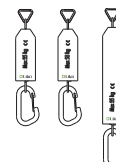

Liko Bathing Chair

Contact Liko/Hill-Rom for further information.

Prod. no. 3156025



SlingBar Cover Paddy 30

Fits Universal SlingBars 350, 450 and 600,
as well as SlingBar Slim 350

Prod. no. 3607001



Hang-up HandControl Hanger

Sold in set of 10 pcs.

Prod. no. 3156100



Multi-Connector

Intended for installation on Likorall for control of switches
and/or if the rail system is equipped with a MultiStation
for charging via the rail.

Prod. no. 3126111

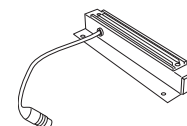

Transfer motor Likorall ES

Fits Likorall with ES designation
Max. 250 kg (550 lbs)

Prod. no. 3126044

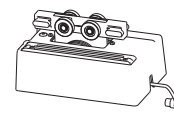

HandControl Remote IR

Likorall with ES designation can be equipped with a
wireless hand control (IR). The hand control operates
normally within a range of 0-5 meters (0-196 inch.) from the lift.

Prod. no. 3126060

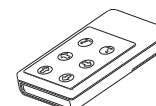

Quick-Release Carriage LR

Fits the Quick-release Adapter LR prod. no. 3126009

Prod. no. 3126008

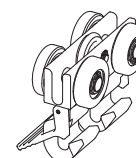

Quick-Release Adapter LR

Fits Quick-Release Carriage LR prod. no. 3126008

Prod. no. 3126009

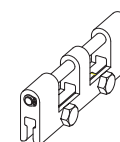

Easy Switch

Developed for users/patients who have reduced strength
or movement of the hand. Easy to install on the hand control.

2-button

4-button

Fits Likorall hand controls prod. no. 3126034,
3126035 and 3126036.

Prod. no. 3107010

Prod. no. 3107011

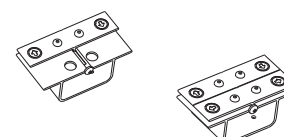

Parking Panel 600, LR/MR
Parking Panel 1500, LR/MR

Can be completed with the following accessories:

Hook for SlingBar

Hook for Accessories

Bracket for Charger

Quick Reference Guide (see respective product)

Prod. no. 3126075

Prod. no. 3126080

Prod. no. 3126070

Prod. no. 3126071

Prod. no. 3126100

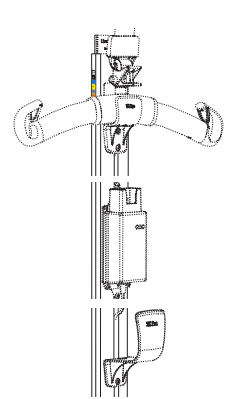

Simple Troubleshooting

The lift doesn't work



1. Check to ensure that the emergency stop button is not pressed in.
2. Check that the hand control is correctly connected.
3. Charge the battery.
4. *If the lift still does not work properly, please contact Liko/Hill-Rom.*

A repeated signal can be heard from the lift



1. Charge the battery immediately.
2. *If the lift still does not work properly, please contact Liko/Hill-Rom.*

The lift stops in the high position



1. Check to ensure that the emergency stop button is not pressed in.
2. Check that the hand control is correctly connected.
3. Use the selected mechanical or electrical emergency lowering device to lower the patient onto a firm surface.
4. Charge the battery.
5. *If the lift still does not work properly, please contact Liko/Hill-Rom.*

The lift does not achieve maximum lifting capacity



1. Charge the battery.
2. *If the lift still does not work properly, please contact Liko/Hill-Rom.*

In event of unusual sounds or any leakage from the lift



Please contact Liko/Hill-Rom.

Inspection and Maintenance

Care and Maintenance

For trouble-free operation, certain details should be checked each day the lift is used:

- Inspect the lift and check to make sure that there is no external damage.
- Check the sling bar attachment.
- Check the lift strap for wear and to ensure the strap is not twisted.
- Check the functionality of the latches.
- Check the operation of the lift movement.
- Check to make sure that the emergency lowering functions correctly.
- Check that the mechanical emergency lowering functions and that the lifting height is set correctly.
- Charge the batteries each day the lift is used and check to ensure that the charger works.

When necessary, clean the lift with a moist cloth, using warm water or disinfectant.

NOTE! Do not use cleaning agents that contain phenol or chlorine, since these can damage aluminium and plastic materials.

△ The lift should not be exposed to running water.

Service

Likorall should be periodically inspected at least once a year.

△ Periodic inspection, repair and maintenance should be performed only in accordance with the Liko Service Manual and by personnel authorized by Liko and using original Liko spare parts.

Service Agreement

Liko offers the opportunity to enter into service contracts for the maintenance and periodic inspection of your Liko products.

Expected Life Time

The product has an expected life time of 10 years when correctly handled, serviced and periodically inspected in accordance with Liko's instructions.

Transport and Storage

During transportation, or when the lift is not to be used for a long time, the emergency stop should be engaged. The environment where the lift is transported and stored should have a temperature of 10–40 °C (50–104 °F) and a relative humidity of 30 to 75 %. The air pressure should be 700–1060 hPa.

Recycling

For instructions on how to recycle your Liko product, please visit our website: www.liko.com.

Product Changes

Liko's products undergo continuous development, which is why we reserve the right to make product changes without prior notice. Contact your Liko/Hill-Rom representative for advice and information about product upgrades.

Design and Quality by Liko in Sweden

Liko is quality certified in accordance with ISO 9001 and its equivalent for the medical device industry, ISO 13485. Liko is also certified in accordance with environmental standard ISO 14001.



A  Company

www.liko.com

Manufacturer:

Liko AB
SE-975 92 Luleå
Sweden
info@liko.se