

OWNER'S MANUAL

US

Permobil M400

Power Wheelchair

The Permobil logo is a blue oval with a white border, containing the word "permobil" in white lowercase letters. It is positioned at the bottom center of the page, overlapping the lower part of the wheelchair tire.

permobil

Permobil M400

Power Wheelchair

Produced and published by Permobil AB, Sweden
Edition: 2, 2012-11
Order no. 205258-US-0

| | |
|--|-------------|
| Important Information | 6-7 |
| Safety Instructions | 8-23 |
| Design and Function | 24 |
| General - Overview..... | 24 |
| Driving - Shock absorbers | 25 |
| Wheels..... | 26 |
| Lights, Reflectors..... | 26 |
| Batteries - Main fuse - Charger Socket | 27 |
| Seat | 28 |
| VR2 control panel | 30 |
| R-Net control panel LCD monochrome display - design and function | 38 |
| R-Net control panel LCD color display - design and function | 46 |
| R-Net control panel LED - design and function | 56 |
| Handling | 63 |
| General - Driving | 64 |
| Joystick error - VR2..... | 65 |
| Joystick error - R-Net | 66 |
| Driving Technique..... | 67 |
| Seat functions..... | 70 |
| Driving Rules | 76 |
| Manual Release of the Magnetic Wheel Locks | 81 |
| Battery Charging..... | 82 |
| Transport | 84 |
| General Advice for Air transport..... | 86 |
| Maintenance and Repairs | 88 |
| Tool Kit | 88 |
| General Batteries/Storage | 89 |
| Finishes Care and Maintenance..... | 90 |
| Changing the Batteries..... | 94 |
| Resetting the Circuit Breaker | 98 |
| Accessories | 99 |
| Technical Specifications..... | 100 |
| Troubleshooting Guide | 102 |
| Important Information about Electromagnetic Interference (EMI) | 109 |

Important Information about this Owner's Manual

We congratulate you on your choice of power wheelchair. Our goal is for you to continue to feel satisfied with your choice of both vendor and wheelchair.

Before you begin using your wheelchair, it is important that you read and understand the content of these operating instructions and in particular the Safety Instructions.

These operating instructions are primarily intended to acquaint you with the functions and characteristics of the wheelchair and how you can use them in the best manner possible. They also contain important safety and maintenance information, as well as describing possible problems that can arise while driving the wheelchair.

Always keep these operating instructions handy in connection with your wheelchair, since the need for important information can arise concerning its use, safety and maintenance.

It is also possible to obtain information concerning our products from our home page on the Internet. You can find us at www.permobil.com.

All information, pictures, illustrations and specifications are based upon the product information that was available at the time that these operating instructions were printed. Pictures and illustrations that are found in these operating instructions are representative examples and not intended to be exact depictions of the various parts of the wheelchair.

We reserve the right to make changes to the product without prior notice.

Ordering of Documentation

If you are in need of another copy of the Owner's Manual, it can be ordered from Permobil, ask for item No. 205258-US-0.

Indication for Use

The intended use of the M400 series of the powered wheelchair is to provide indoor and outdoor mobility to persons limited to a seating position that are capable of operating a powered wheelchair. The M400 series of the powered wheelchair is intended for sale OTC.

TECHNICAL SUPPORT

In the event of technical problems, you should contact your dealer or Permobil Inc USA at 1-800-736-0925.

Always state the chassis serial number when contacting Permobil to ensure that the correct information is provided.

SPARE PARTS & ACCESSORIES

Spare parts and accessories must be ordered through your dealer.

SCRAPPING THE WHEELCHAIR

Contact Permobil Inc. for information about scrapping agreements in force.

WARRANTY

A warranty registration card is attached to each new wheelchair. The Permobil Inc. Product Warranty Information sets forth the conditions of the warranty.

Contact your dealer or Permobil Inc USA for information about the warranty period for this wheelchair.

Safety Instructions - General

An electric wheelchair is a motorized vehicle and special care must therefore be taken when it is used. Please read and follow all instructions and warnings in this manual before operating your Permobil powered wheelchair. Incorrect use may both injure the user and damage the chair. In order to reduce these risks, you should read the Owner's Manual carefully, in particular the safety instructions and their warning texts.

Throughout this manual the following symbol will be used to note items that have significant importance to safety concerns:

CAUTION!

Please use caution where this symbol appears.

WARNING!

Please use extreme caution where this warning symbol appears. Failure to observe warnings can lead to personal injury and property damage, including damage to the wheelchair.

Permobil is not responsible for personal injuries or property damage resulting from any person's failure to follow the warnings and instructions in this manual. Permobil is not responsible for injuries or damage resulting from failure to exercise good judgment.

The final selection and purchasing decision about the type of electric wheelchair to be used is the responsibility of the wheelchair user and his or her healthcare professional. Permobil Inc. is not responsible for inappropriate selections of wheelchair models or features or improper fitting of the wheelchair.

Safety Instructions - General

Your wheelchair was configured specifically for your needs as prescribed by your healthcare provider. Consult your healthcare provider before changing the seat position or making any other adjustment. Some adjustments may reduce your wheelchair's performance or safety or may not be appropriate for your needs.

It is also of the utmost importance that you devote sufficient time to become acquainted with the different buttons, the function and steering controls, the different adjustment possibilities of the seat, etc. of your wheelchair and its accessories before you begin using it.

Do not undertake your own first test drive without making sure that you have assistance in the immediate vicinity if you should need help.

In order to make sure that nothing happened to the wheelchair while it was being shipped to you, you should check the following items before beginning to use it:

- that all products ordered are included in the delivery, including operating instructions and possible other documentation. If you suspect that something is missing, then contact your supplier or Permobil for more information as soon as possible.
- that no transport-related or other damages have occurred to the wheelchair and its accessories. If you discover that something has been damaged or in some other manner appears to be incorrect, then contact your supplier or Permobil for more information as soon as possible before you continue the checks.

We recommend that you charge your wheelchair's batteries before you begin using it. The chapter titled "Charging the Batteries" describes how to do this.

Always be sure that tires are inflated properly before driving.

If you experience that the wheelchair in any manner is not behaving as expected or if you suspect that something is wrong: abort the test drive as soon as possible, shut off the wheelchair and get in touch with your service contact or Permobil for more information.

Safety Instructions

WARNING!

Operation

Permobil recommends the use of wheelchair lights at all times user is riding near public rights of way. Use extreme caution when driving near unprotected ledges, drop-offs or on elevated surfaces. Unintended movement or excessive speed in these areas can lead to personal injury or property damage.

Do not drive the wheelchair over any curbs or edges higher than 3 inches. When driving over a curb or similarly elevated surface, you must cross the surface at a 90 degree angle (perpendicular). Crossing such surfaces at any other angle may result in the wheelchair tipping.

Reduce your speed when driving on uneven terrain or soft surfaces. Do not use your wheelchair on stairs or escalators. Always use an elevator.

Do not lift or move the wheelchair by any of its removable parts. Doing so could lead to personal injury and property damage, including damage to the wheelchair.

CAUTION!

Operation

Do not let children drive the wheelchair without supervision. Do not drive the wheelchair on public streets or roadways. Obey all local pedestrian rules and be aware that vehicle drivers may have difficulty seeing you.

Do not operate your wheelchair under the influence of alcohol. Consumption of alcohol may impair your ability to operate your wheelchair safely.

Some physical limitations or use of medication, either prescribed or over-the-counter, may limit your ability to operate your wheelchair safely. Be sure to consult with your physician about your physical limitations and medications.

Safety Instructions

WARNING!

Modifications

Any unauthorized modifications to the wheelchair or its various systems may increase the risk of personal injury and property damage, including damage to the wheelchair.

All modifications to and interventions in the vital systems of the wheelchair must be performed by a qualified service technician authorized by Permobil to perform such service on Permobil products.

Weight Limitations

The maximum user weight for your Permobil is set forth in the specification section of the supplied Owner's Manual for current seat model. Operation of the wheelchair by users who exceed the maximum allowable user weight can lead to personal injury and property damage, including damage to the wheelchair, as well as voiding any applicable warranty to the wheelchair.

Do not carry passengers on the wheelchair. Doing so can lead to personal injury and property damage, including damage to the wheelchair.

Positioning Belts

Always wear your positioning belt while in your wheelchair. If signs of damage or wear appear, replace the positioning belt immediately through your Permobil dealer.

CAUTION!

Prior to Riding

In some instances, including where certain medical conditions exist, users should practice operating their wheelchair under the supervision of an assistant who is familiar with the operation of the wheelchair and with the abilities and limitations of the user.

Safety Instructions

CAUTION!

Operation - Inclines

When driving downhill, select the slowest speed and proceed with caution. Driving down an incline in a front wheel drive wheelchair can shift the user's center of gravity forward. If the wheelchair rolls faster than you would like, stop the wheelchair by releasing the joystick and begin descending again at a slower speed.

Avoid sudden stops or starts. Stop by releasing joystick rather than by turning the power off. Turning off power while the wheelchair is in motion will cause the wheelchair to stop suddenly.

When driving up an incline, try to keep moving at a steady speed. Stopping and starting the chair while moving up an incline makes the wheelchair more difficult to control.

Do not drive up or down slopes with a gradient greater than indicated in the technical specifications section of the manual. There is a risk that the wheelchair will not maneuver safely.

Safety Instructions

WARNING!

Operation - Inclines

Do not drive the wheelchair where the sideways gradient is more than indicated in the technical specifications section of the manual. There is a risk of tipping over.

Do not drive up or down ramps that are not equipped with proper edge protection along the sides of the ramp to prevent the wheelchair from falling off of the ramp.

When driving up an incline, be sure to drive your wheelchair straight up the incline (perpendicular). Driving at an angle up an incline increases the risk of tipping or falling. Use extreme caution when driving up an incline.

Do not drive down or up a hazardous incline, such as a surface covered with snow, ice, or wet leaves or a surface that is uneven. Also avoid driving on ramps that do not have proper edge protection.

Safety Instructions

WARNING!

Operation - Turning

Turning your wheelchair at high speeds can create the possibility of the wheelchair tipping and personal injury. The possibility of tipping can be increased by high turning speed, sharp turns, uneven surfaces, abrupt changes in direction, and driving from an area of low traction (e.g. lawn) to an area of high traction (e.g. sidewalk).

To protect against tipping, personal injury and property damage, reduce speed and reduce the sharpness of your turn when turning.

Operation - Freewheel Mode

In order to prevent the wheelchair from rolling away, ensure that the wheelchair is on a level and dry surface before releasing the brakes.

In order to avoid personal injury do not use your Permobil in freewheel mode without an attendant present. Do not attempt to put the wheelchair in freewheel mode by yourself while seated in it.

Do not put your Permobil in freewheel mode while on an incline. This could cause the wheelchair to roll on its own, causing injury and property damage, including damage to the wheelchair.

Safety Instructions

CAUTION!

Driving on a Loose or Soft Surface

When the wheelchair is set to its lowest speed and the batteries are not fully charged, driving on certain surfaces, for example gravel, sand or thick carpeting, can involve constrained navigability.

Driving in Darkness

Driving in the dark may only be done if your wheelchair is equipped with functioning lighting in the front and the back, or as per the applicable national or local traffic regulations.

Driving in Extreme Climate Conditions

Permobil's wheelchairs are designed to withstand most adverse weather conditions, however to minimize the risk of being caught in difficult situations you should avoid using the wheelchair outdoors during, for example, severe cold, heavy rain or thick snow.

Also bear in mind that certain surfaces on the wheelchair can be heated up or cooled down in the event of prolonged exposure to intense sunlight or cold respectively.

Safety Instructions

WARNING!

Driving with Seat Lift/Seat Tilt/Backrest Recline

Be careful in making sure that nothing gets stuck between the chassis and the seat when the seat lift/seat tilt is operated. Operating the seat lift, seat tilt/backrest recline changes the center of gravity and increases the risk of tipping over. Always drive in low speed and only use those seat functions on level ground, and not on hills, ramps, slopes or other inclines. Using those seat functions while driving on inclines can lead to personal injury and property damage, including damage to the wheelchair.

Center of Balance

The possibility of this wheelchair tipping and the point where this wheelchair will tip forward, back or to the side depends on its center of balance. Please note that the following factors can affect the wheelchair's center of balance:

- Elevation of the seat
- Height and angle of the seat
- Body position or weight distribution
- Driving on an incline such as a ramp or a hill
- Use of a backpack or other accessories, depending on the amount of weight added.

If your wheelchair begins to move in an unexpected manner, immediately release the joystick to stop the wheelchair. Except in an emergency, do NOT use the on/off button to stop your wheelchair, as this will cause the wheelchair to stop abruptly and may cause personal injury.

Fixed seat post

Adjusting the seat height may only be performed by an authorized service provider. See the service manual for more information.

Safety Instructions

⚠ WARNING!

Transfer into and out of the chair

Be sure that the power is turned OFF before entering or leaving the wheelchair and before lifting the control side armrest.

When transferring into or out of the wheelchair, every precaution should be taken to reduce the distance between the wheelchair and the place to which the user is transferring. Overextending this distance can cause user to over-exert, lose balance, or fall.

Permobil recommends that users transfer in the presence of or with the assistance of an attendant.

Use caution when bending or reaching.

Never use the joystick as a handhold or point of support.

Do not use foot plates or armrests as supports when transferring into or out of the wheelchair. The footplates and armrests are not designed to be weight-bearing structures. Excessive force may cause them to give way, resulting in personal injury or property damage, including damage to the wheelchair.

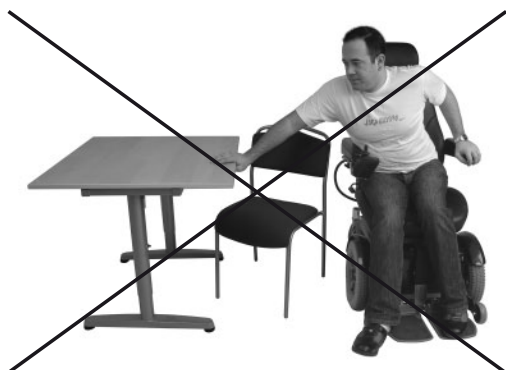

Safety Instructions

WARNING!

Passengers

The wheelchair is not intended to transport passengers, regardless of the age of the passenger. The Maximum User Weight stated in the Owner's Manual for your seating includes the user and any personal effects. The Maximum limit should not be exceeded. The wheelchair's maneuverability and stability can be degraded as a result.

Environmental Conditions

Protect your wheelchair from exposure to any type of moisture, including rain, snow, or wash. Exposure to moisture can cause the chair to short-circuit, catch fire and cause personal injury or property damage. Do not operate your wheelchair if it has been exposed to moisture until it has dried completely.

If any of the shrouds or the joystick boot has cracks or tears, they must be replaced immediately. Failure to do so can allow moisture to enter the electronics and cause personal injury or property damage, including fire.

Do not operate your wheelchair in icy or slippery conditions. These conditions can lower the performance and safety of your wheelchair which could lead to an accident, personal injury and property damage, including damage to the wheelchair.

CAUTION: *Extreme care should be exercised when using oxygen in close proximity to electric circuits and other combustible materials. Contact your oxygen supplier for instruction in use of oxygen.*

Safety Instructions

WARNING!

Transport

The wheelchair must be transported in or with transport solutions that have been approved for this purpose.

Check that the wheelchair is properly secured and that the wheel locks are not disengaged. The wheelchair can be locked into position by running fastening straps through the brackets at the front and back. Also check that the fastening points on the transport vehicle are well-anchored.

A defectively fastened chair can cause serious injury to persons in the vehicle and serious damage to the vehicle.

Use Prohibited in Motor Vehicles

Permobil recommends that users NOT be transported in any kind of vehicle while in their wheelchair, unless the user is in an approved Permobil wheelchair configuration, has secured the wheelchair using a Permolock C3, and is using a seatbelt attached to the vehicle. The only other safe alternative is that users be transferred into factory vehicle seating for transportation and use safety restraints made available by the auto industry. The only wheelchair transportation system Permobil recommends is a Permolock C3 used in combination with an approved Permobil wheelchair.

Unless using a Permolock C3 with an approved Permobil wheelchair, never sit in your wheelchair while in a moving vehicle. In an accident or sudden stop, you may be thrown from the chair and seriously injured or killed.

Permobil positioning belts are designed to position the user only and not to protect you in the event of a motor vehicle accident. The positioning belts do not replace use of a vehicle mounted restraint.

Safety Instructions

WARNING!

Maintenance and Service

Carry out only the service and maintenance which are stated in the Owner's Manual. All other service and maintenance must be performed by a qualified service technician authorized by Permobil to perform such service on Permobil products

During all work on the electrical system of the wheelchair, the Circuit Breaker must always be in OFF position. To avoid the risk of electric shock, use extreme caution when using metal objects while working on the batteries. Short-circuiting can easily cause an explosion. Never perform service on the wheelchair without using protective gloves and goggles. Failure to do so can lead to personal injury.

Do not use parts or accessories not authorized by Permobil. Use of unapproved "aftermarket" accessories and parts may cause changes in the wheelchair, which may make the wheelchair unstable or uncontrollable. Such use may also void the warranty on the wheelchair.

Connecting any unapproved electrical or electronic devices to the wheelchair's electrical system can cause damage to the chair and caused the chair to become uncontrollable or drive erratically. Such use may also void the warranty.

The wheelchair is heavy and contains many moving parts, which means that the risk of being caught between them is always present.

Charging of Batteries

Charging must be done in a well-ventilated room, not in a wardrobe or closet. Charging must not be done in a bathroom or wet room. Only chargers with a max 10 A charging current (average value) may be used (the RMS value of the charging current must not exceed 12A). When the charger is connected, the chair must not and cannot be driven.

Safety Instructions

WARNING!

Safety Circuits

Permobil products are equipped with safety circuits. Inhibit circuits prevent the wheelchair from driving under certain conditions. Speed reduction circuits limit the wheelchair's maximum speed under certain conditions. Limit switch circuits limit the wheelchair's functions under certain circumstances. Overload protection circuits shut the wheelchair off in case of an overload. The user should stop using the wheelchair immediately and consult an authorized Permobil distributor if any of these circuits should become disabled.

Any attempt to modify the safety circuits will result in unsafe operation of the wheelchair and could cause the chair to become unstable or uncontrollable. Such modifications may also void the wheelchair's warranty.

Changing Batteries and Fuses

The Circuit Breaker must always be in OFF-position when batteries and fuses are replaced.

Observe care in the use of metallic objects when working with batteries. A short-circuit can easily cause an explosion. Always use protective gloves and protective eye-glasses.

Filling Air into tires

Check at regular intervals that the wheelchair's tires have the prescribed tire pressure. Incorrect tire pressure can cause deteriorating stability and maneuverability.

The prescribed tire pressure is 29 psi (200 kPa).

Note that overfilling causes a risk of explosion.

Safety Instructions

WARNING!

Changing Tires

Avoid the use of sharp-edged tools when working with tires.

Storage

The wheelchair and its accessories must always be shut off when they are not being used. Always store the wheelchair so that access for unauthorized individuals is avoided.

Never store the wheelchair in a room in which condensation can arise (mist or dampness on the surfaces) e.g. in pool areas, laundry rooms, or similar rooms.

If you are unsure as to how your wheelchair and its accessories should be properly stored, contact your equipment supplier or an Authorized Permobil provider for more information.

Damages/malfunctions on the wheelchair and its accessories

If you experience that the wheelchair in any manner is not behaving as expected or if you suspect that something is wrong: Stop driving as soon as possible, shut off the wheelchair and contact an Authorized Permobil service center or Permobil for more information.

It's also of greatest importance that Permobil be informed if the wheelchair and its accessories have been subjected to transport damages, damages during driving or damages due to another cause as soon as possible after the event. There exists a risk that the wheelchair and its accessories can no longer be used in a safe and secure manner.

Safety Instructions

CAUTION!

Recycling of Batteries

Used or broken drive batteries should be taken care of in an environmentally correct manner in accordance with locally applicable recycling directions.

EMC Requirements

The electronics of an power wheelchair can be affected by external electromagnetic fields (for example from mobile telephones). Similarly, the electronics of the wheelchair itself can also emit electromagnetic fields that can affect the immediate surroundings (for example certain alarm systems in businesses).

The limit values for Electromagnetic Compatibility (EMC) with respect to power wheelchairs is set in the harmonized standards for the EU in the Medical Devices Directive, No. 93/42/EEC.

Permobil's electronic wheelchair's comply with these limit values.

Also see Important Information about **Electromagnetic Interference (EMI)** on page 109-110.

Design & Function

General

The Permobil M400 is an electric mid-wheel drive wheelchair for outdoor and indoor driving. It is intended for people with physical disabilities.

The wheelchair consists of a chassis and a seat. The chassis contains the wheelchair's electronics, power supply and drive functions. The seat consists of a seat frame, seat plate/back rest, arm rest/leg rest, seat lift/fixed seat tube and any accessories/options such as a head rest, calf rest, chest support, etc.

In this owner's manual, we have chosen to show the wheelchair with our Corpus 3G-seat. However, the operation of the chassis and most of its functions are the same regardless of the seat model chosen.

Overview



- | | |
|------------------|------------------------|
| 1. Back rest | 6. Front caster wheels |
| 2. Control panel | 7. Drive wheels |
| 3. Seat | 8. Rear caster wheels |
| 4. Leg rest | 9. Chassis |
| 5. Foot plates | 10. Arm rest |

Driving

The Permobil M400 is equipped with a drive package for each drive wheel. The drive package consists of an electric motor with a drive gear and magnetic wheel lock.

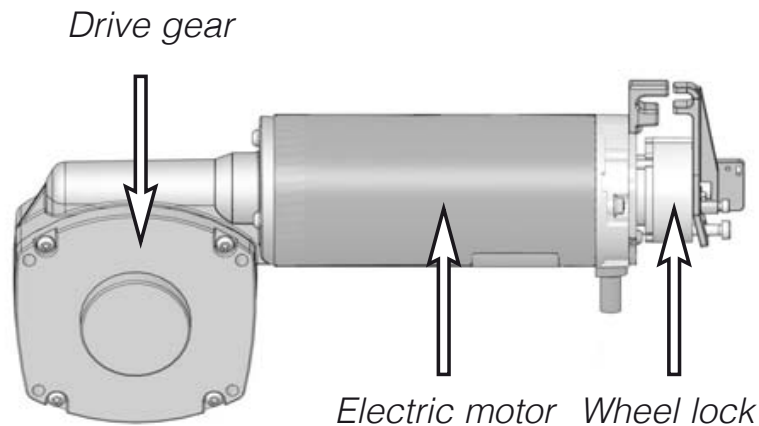

Shock absorber

The wheelchair is equipped with four shock absorbers.

Adjustment

Adjustment should be performed by personnel who are well-acquainted with the design and functionality of the M400. When adjustment is needed, contact your nearest Authorized Permobil Service Center.

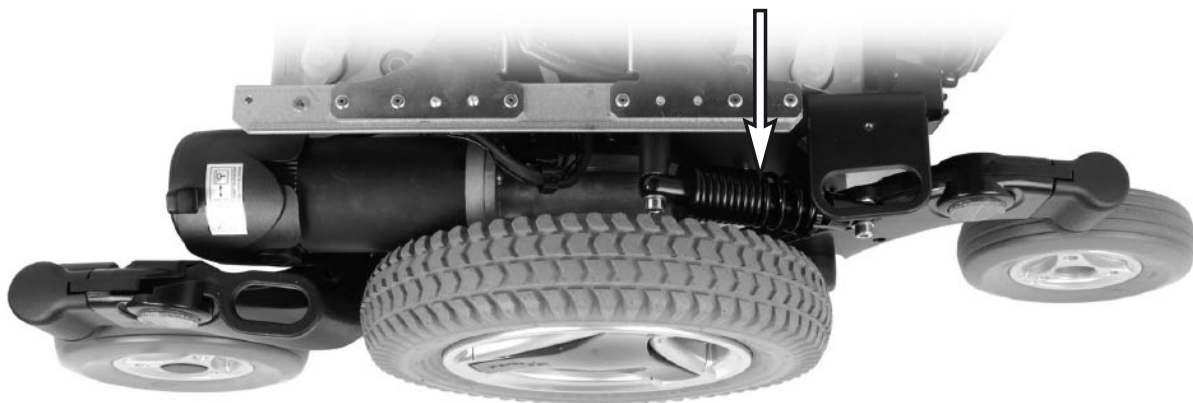

Shock absorber.

Wheels

The wheelchair's rear wheels, the drive wheels, are available with pneumatic or Flat-Free (Foam Filled) tires. The front wheels, the caster wheels, have solid polyurethane tires.

Lights and reflectors

The wheelchair is equipped with reflectors on the front, rear and sides. Front/rear lights and turn indicators are optional.



Front reflectors



Rear reflectors



Side reflectors

Batteries

The wheelchair's batteries are located under the covers of the chassis. Both of the batteries are easily accessible for maintenance and replacement.

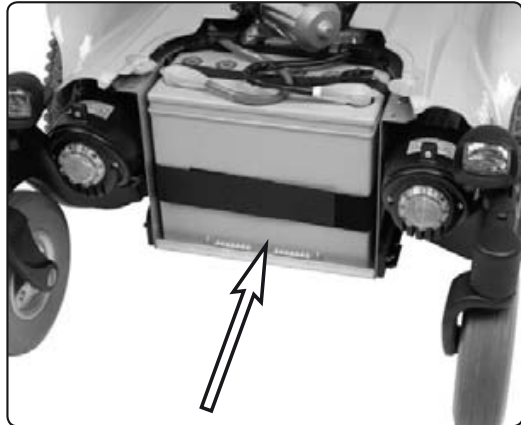

Front battery.

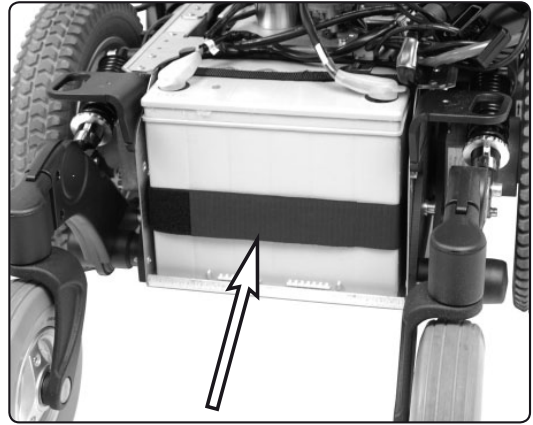

Rear battery.

Circuit Breaker

The M400 is equipped with an automatic Circuit Breaker, which can be reset after having been triggered. It also functions as a battery isolator and is controlled (ON/OFF) via the lever located inside the hole at the bottom of the rear battery cover.

Charging socket

The charging socket is located on the control panel.

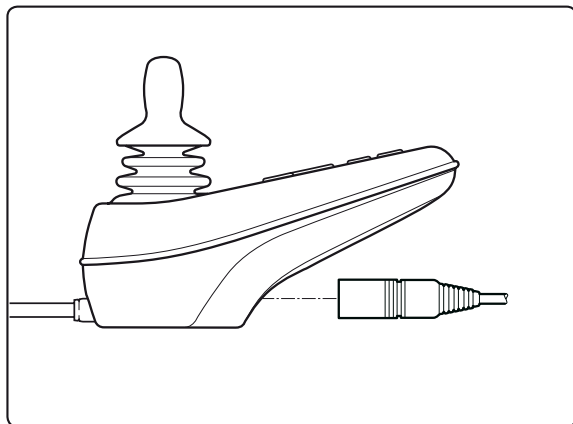

*Charging Socket on VR2
Control Panel.*

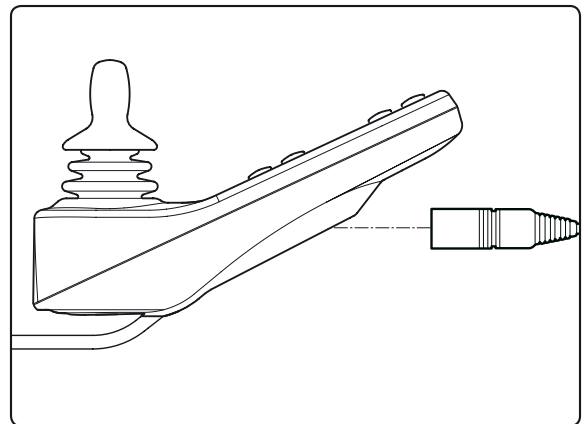

*Charging Socket on R-net
Control Panel.*

Seat

Permobil M400 can be combined with different seat models, which are supplied with a separate user manual. The seat's electrical functions are operated using the control panel or the seat's ICS control panel (if your wheelchair is so equipped). For safety reasons, the seat's electrical functions may in certain situations restrict the usage of other seat functions or the wheelchair's maximum speed. In certain situations a seat function may even prevent the wheelchair from moving.

Seat lift

Permobil M400 can be fitted with an electrically controlled seat lift that allows the seat to be raised steplessly up to 8 inches in order to adjust its height to tables, benches, etc.

Seat angle

Permobil M400 can be fitted with an electrically controlled seat angle function that makes it possible to adjust the seat angle steplessly up to 50°.



Seat lift



Seat tilt

Leg rest

WARNING!

The following applies only if your wheelchair is equipped with separate foot plates.

With the wheelchair kept still and having the leg supports driven towards it's innermost position, the wheelchair's front wheels must always be kept in a 90 degrees straight position, (A), pointed forward or backwards. With the front wheels pointed sideways, (B), there is a risk that the leg rest with foot plates might be damage if they are hit against the front wheels.

There is also a risk for the user to get caught between the foot plates and wheels.



B. Correct angle front wheels

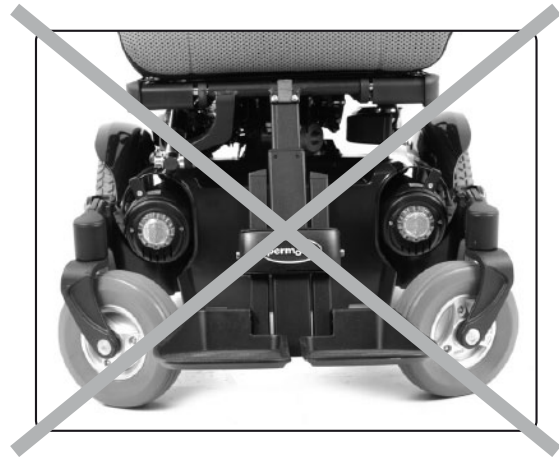

B. Incorrect angle front wheels

VR2 Control Panel

The VR2 Control Panel consists of a joystick, function buttons and indicator lights.

VR2 control panel overview



The number of function buttons/indicator lights depends on the configuration of the wheelchair, for example, with or without lights and seatfunctions.

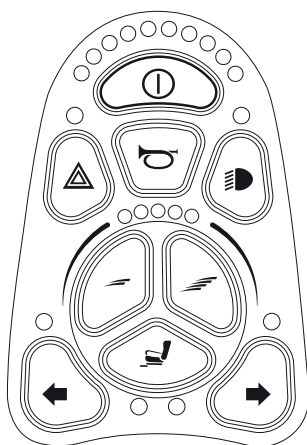

Control panel on M400 with lights and seatfunctions.

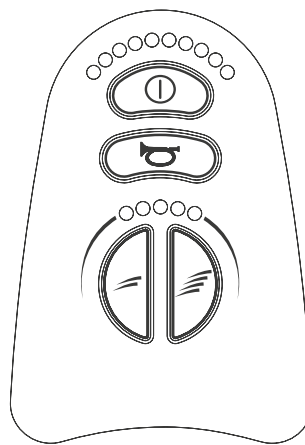

Control panel on M400 without lights and seatfunctions.

VR2 Control Panel

Charger/Programming Socket

This socket should only be used for charging the wheelchair. A VR2 compatible Hand-held or PC Programmer can be connected to this socket, in order to make changes to the wheelchair's driving characteristics. This socket should not be used as a power supply for any other electrical device. Connection of other electrical devices may damage the control system or affect the E.M.C. performance of the wheelchair.

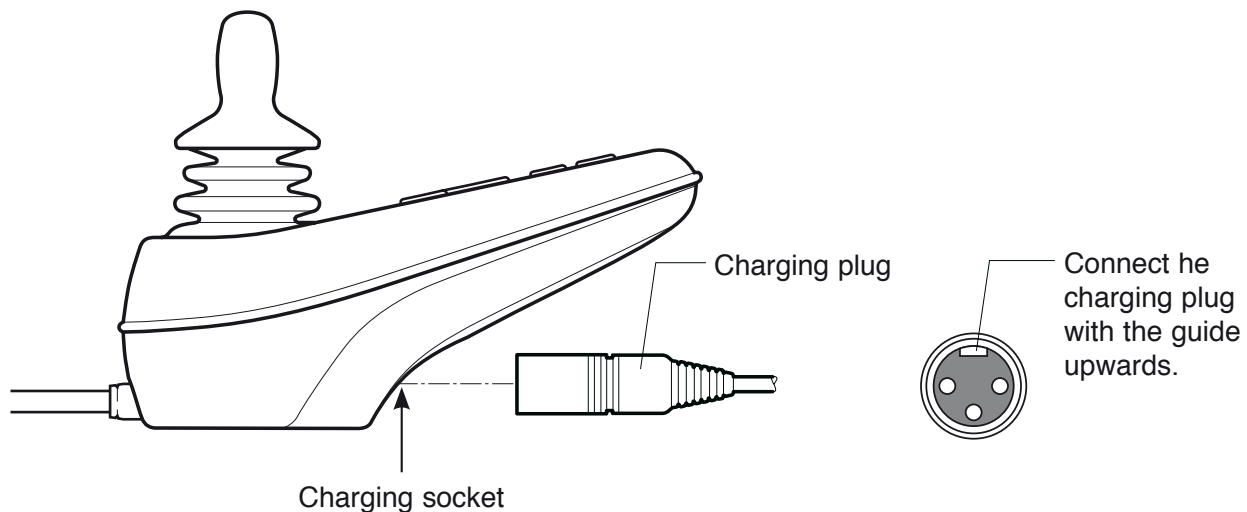

⚠ WARNING!

The wheelchair's warranty will be voided if any device other than a battery charger supplied with the wheelchair, or the lock key is connected into the control panels charger socket.

VR2 Control Panel

Function Buttons

On the control panel there are a total of 10 Function Buttons. The number of function buttons depends on the wheelchairs configuration.

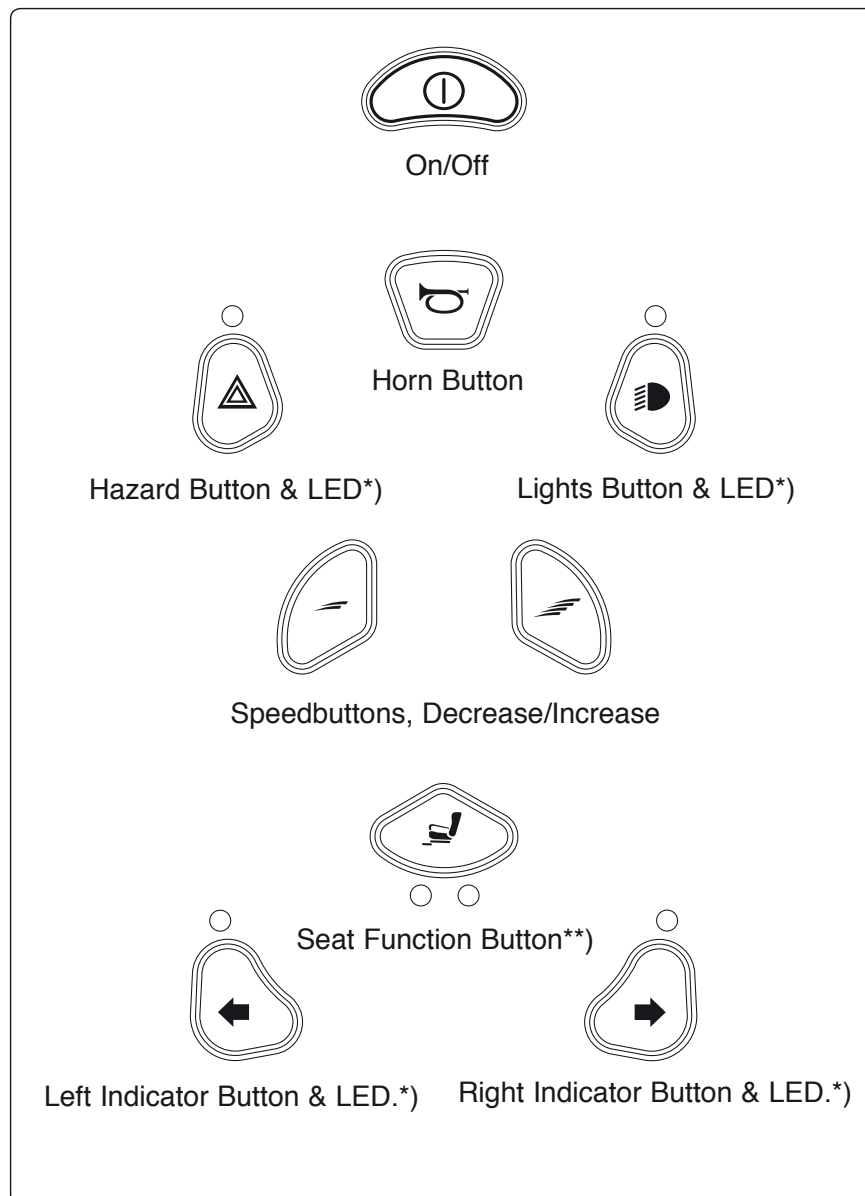

*) Only on wheelchairs with lights.

***) Only on wheelchairs with electric seat functions.

VR2 Control Panel

Power Switch, On/Off

Button to power up and power down the wheelchair. This button must be pressed for the chair to operate.

WARNING!

Do not use the Power Switch Button to stop the wheelchair unless there is an emergency. If you do, you may get thrown out of the chair or shorten the life of the wheelchair drive components.

Warning Horn

Press the button to sound the horn and attract attention.

Hazard Warning Button and LED*)

This button activates/deactivates the wheelchairs hazards lights. this function is used when the wheelchair is positioned in a way making it a obstruction for others. Push the button to activate the hazard lights and push it again to deactivate them. When activated the indicator LED will flash in sync with the wheelchair's indicators.

Lights Button*)

This button activates/deactivates the wheelchair lights. Push the button to activate the lights and push it again to deactivate them. When the lights are activated the light LED lights up too.

Maximum Speed Buttons

These buttons decrease/increase the maximum speed setting. In special circumstances, the drive electronics can be programmed to use Profiles. When Profiles are programmed, these buttons allow the user to change the profile of the control system, instead of adjusting the maximum speed.

Seat Function Button**)

If the wheelchair is fitted with seat actuators, this button will enter and exit actuator adjustment mode.

Turning Indicator Buttons*)

This buttons activates and deactivates the wheelchair's left/right indicator. Depress the button to turn the indicator on and depress the button again to turn it off. When activated the indicator LED will flash in sync with the wheelchair's indicators.

*) Only on wheelchairs with lights.

***) Only on wheelchairs with electric seat functions.

VR2 Control Panel

Battery Charge Indicator

The battery charge indicator lets you know approximately how much charge is left in your batteries (from left to right):

| | |
|------------------|------------------------|
| Red+Yellow+Green | = Fully charged |
| Red+Yellow | = Half charged |
| Red | = Charge the batteries |

The best way for you to use the indicator is to learn how it behaves as you drive your wheelchair. Like the fuel gauge in a car, it is not completely accurate, but it gives you a rough idea so that you can avoid unnecessary stops because the batteries are discharged.

The indicator gives you a more accurate reading about a minute after you start driving the wheelchair.

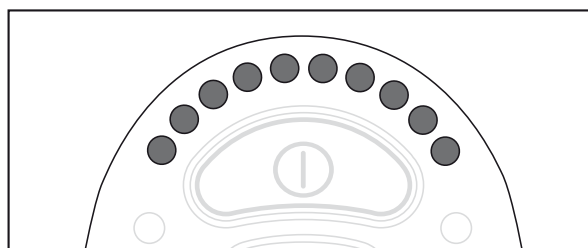

⚠ CAUTION!

The voltage indicator also serves as a "fault indicator" for the wheelchair's electronic system. See page 102-103 for more information.

VR2 Control Panel

Speed display

Speed

Indicates the adjusted speed at which the wheelchair is set.

- 1 - 2 lamps = Low speed
- 3 - 4 lamps = Medium speed
- 5 lamps = Maximum speed

Profile

In special circumstances the wheelchair can be programmed with more than one profile. In these cases, the display shows the selected profile.

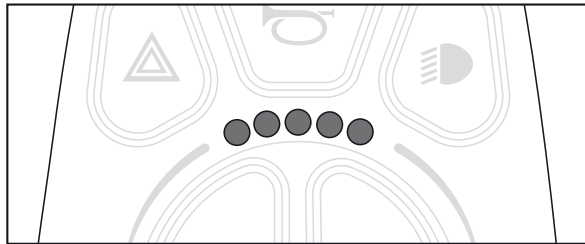

⚠ CAUTION!

The speed display also serves as a "fault indicator" for the wheelchair's electronic system. See page 102-103 for more information

VR2 Control Panel

Locking/Unlocking the Wheelchair

The wheelchair can be locked to prevent unauthorized use.

Locking:

- Make sure the wheelchair is turned on. Press and hold the start up button for approximately 1 sec. until a short "beep", release the button.
- Push the joystick forward until a short "beep", then push the joystick backwards until a short "beep".
- Release the joystick, a longer "beep" indicates that the wheelchair is locked.

Unlocking:

- Turn on the wheelchair, the speed indicator will scroll forward and backward.
- Push the joystick forward until a short "beep", then push the joystick backwards until a short "beep".
- Release the joystick, a longer "beep" indicates that the wheelchair is unlocked.

VR2 Control Panel

Joystick

The joystick is used to regulate the speed of the wheelchair forward or backward, to turn, and to brake.

The speed is regulated proportionally by moving the joystick forward or backward. The wheelchair's travel speed is directly proportional to the movement of the joystick (a small movement gives low speed - a large movement gives high speed).

The wheelchair is turned by moving the joystick to the left or to the right.

The wheelchair is stopped by moving the joystick back to the neutral position or by letting it go.

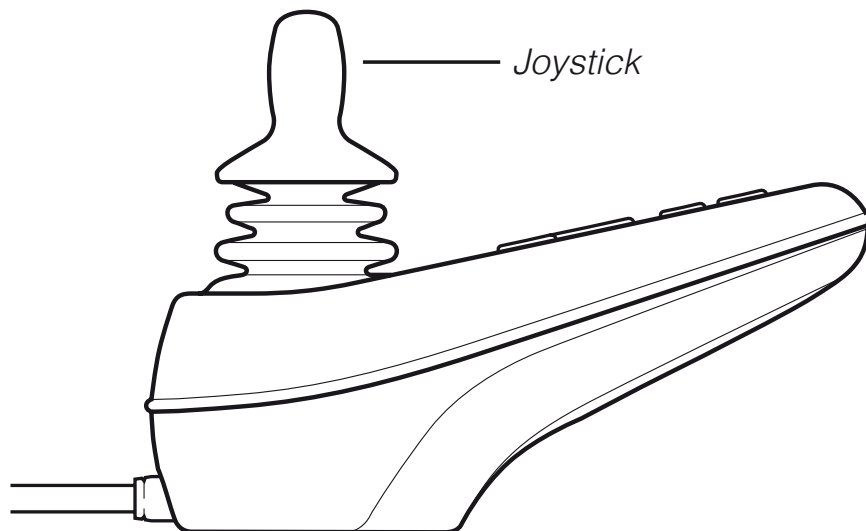

R-Net control panel LCD monochrome display

General

The Control Panel consists of a joystick, function buttons and a display. At the front of the panel is the Charger Socket. Two Jack Sockets are located on the bottom of the panel.

Your wheelchair may also be equipped with a Seat Control Panel in addition to the control panel.

Control Panel Overview



R-Net control panel LCD monochrome display

Charger Socket

This socket should only be used for charging or locking the wheelchair. Do not connect any type of programming cable into this socket. This socket should not be used as a power supply for any other electrical device. Connection of other electrical devices may damage the control system or affect the E.M.C. performance of the wheelchair.)

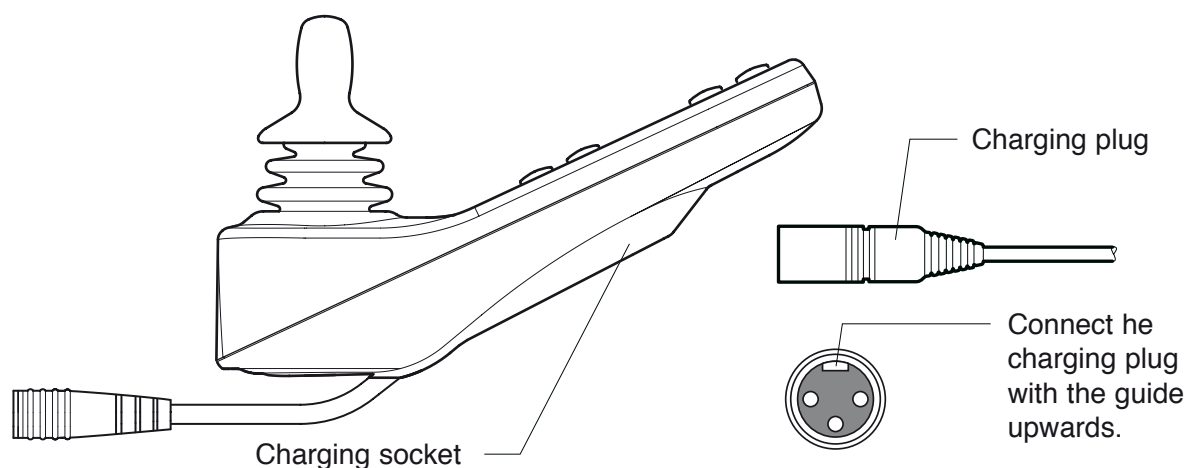

⚠ WARNING!

The wheelchair's warranty will be voided if any device other than a battery charger supplied with the wheelchair, or the lock key is connected into the control panels charger socket.

R-Net control panel LCD monochrome display

Function Buttons

On the control panel there are a total of 10 Function Buttons.

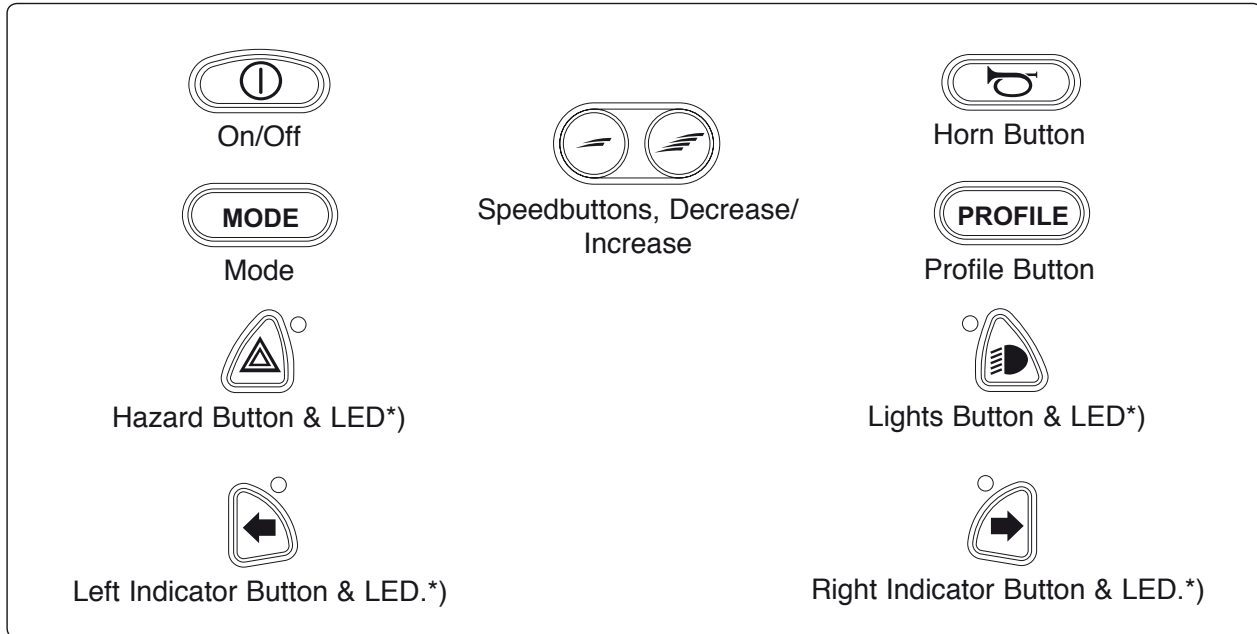

*) Only active if the wheelchair is equipped with lights.

On/Off Button

The On/Off button applies power to the control system electronics, which in turn supply power to the wheelchair's motors.

⚠ WARNING!

Do not use the On/Off Button to stop the wheelchair unless there is an emergency. If you do, you may get thrown out of the chair or shorten the life of the wheelchair drive components.

Horn Button

The horn will sound while this button is depressed.

Maximum Speed Buttons

These buttons decrease/increase the wheelchairs maximum speed. Depending on the way the control system has been programmed a momentary screen may be displayed when these buttons are pressed.

R-Net control panel LCD monochrome display

Mode Button

The Mode button allows the user to navigate through the available operating Modes for the control system. The available modes are dependant on programming and the range of auxiliary output devices connected to the control system.

Profile Button

The profile button allows the user to navigate through the available Profiles for the control system. The number of available Profiles is dependant on how the control system is programmed. Depending on the way the control system has been programmed a momentary screen may be displayed when the button is pressed.

Hazard Warning Button and LED*)

This button activates/deactivates the wheelchairs hazards lights. This function is used when the wheelchair is positioned in a way making it an obstruction for others. Push the button to activate the hazard lights and push it again to deactivate them. When activated the indicator LED will flash in sync with the wheelchair's indicators.

Lights Button and LED*)

This button activates and deactivates the wheelchair's lights. Depress the button to turn the lights on and depress the button again to turn them off. When activated the lights LED will illuminate.

Left Indicator Button and LED*)

This button activates and deactivates the wheelchair's left indicator. Depress the button to turn the indicator on and depress the button again to turn it off. When activated the left indicator LED will flash in sync with the wheelchair's indicator.

Right Indicator Button and LED*)

This button activates and de-activates the wheelchair's right indicator. Depress the button to turn the indicator on and depress the button again to turn it off. When activated the right indicator LED will flash in sync with the wheelchair's indicator.

*)Only active if the wheelchair is provided with lights.

R-Net control panel LCD monochrome display

External On/Off Switch Jack

This allows the user to turn the control system on and off using an external ability switch, such as a buddy button.

External Profile/Mode Switch Jack

(This jack's function varies depending on the programming.)

This allows the user to select Profiles using an external ability switch, such as a buddy button.

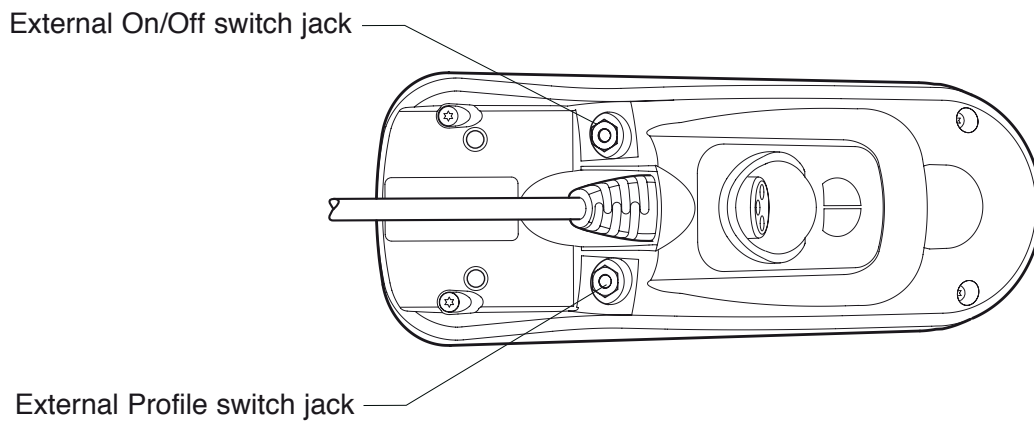

R-Net control panel LCD monochrome display

Display

The status of the control system is shown in the display. The control system is on when the display is backlit.

Screen Symbols

The Drive screen for the R-net has common components, which will always appear, and components which will only appear under certain conditions. Below is a view of a typical Drive screen in Profile 1.



Battery Indicator

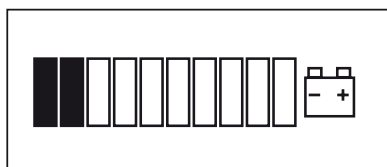

This displays the charge available in the battery and can be used to alert the user of the status of the battery.

Steady

This indicates that all is well.

Flashing Slowly

The control system is functioning correctly, but you should charge the battery as soon as possible.

Stepping Up

The wheelchair batteries are being charged. You will not be able to drive the wheelchair until the charger is disconnected and you have switched the control system off and on again.

R-Net control panel LCD monochrome display

Speed Indicator

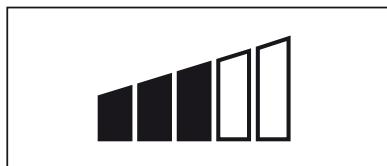

This displays the current speed setting.

The speed setting is adjusted using the Speed Buttons.

Current Profile



The Profile Number describes which Profile the control system is currently operating in. The Profile Text is the name or description of the Profile the control system is currently operating in.

In Focus



When the control system contains more than one method of direct control, such as a secondary Joystick Module or a Dual Attendant Module, then the Module that has control of the wheelchair will display the In Focus symbol.

Speed Limit

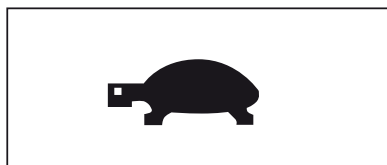

If the speed of the wheelchair is being limited; for example, by a raised seat, then this symbol will be displayed. If the wheelchair is being inhibited from driving, then the symbol will flash.

Restart

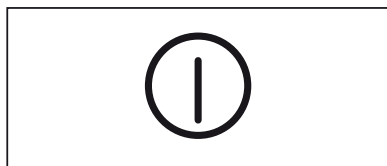

When the control system requires a restart; for example, after a module re-configuration, this symbol will be flashed.

R-Net control panel LCD monochrome display

Fault

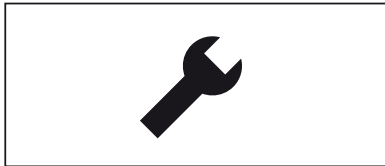

The control system can detect a wide variety of errors. When the system has detected an error that is not severe enough to cause the system to trip, then this symbol will be displayed.

Motor Temperature

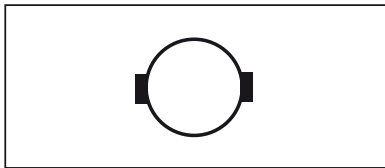

This symbol is displayed when the control system has intentionally reduced the power to the motors, in order to protect them against heat damage.

Control system Temperature

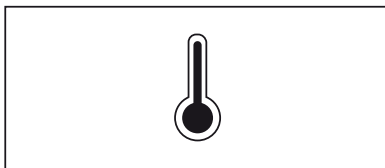

This symbol is displayed when the control system has intentionally reduced its own power, in order to protect itself against heat damage.

Timer



This symbol is displayed when the control system is changing between different states. An example would be entering into Programming Mode. The symbol is animated so that you can see the sand running through the hourglass.

E-Stop



If the control system is programmed for latched operation, then it is normal for an Emergency Stop Switch to be connected into the External Profile Switch Jack. If the Emergency Stop Switch is operated or disconnected, this symbol will flash.

R-Net control panel LCD color display

General

The Control Panel consists of a joystick, function buttons and a display. At the front of the panel is the Charger Socket. Two Jack Sockets are located on the bottom of the panel.

Your wheelchair may also be equipped with a Seat Control Panel in addition to the control panel.

Control Panel Overview



R-Net control panel LCD color display

Charger Socket

This socket should only be used for charging or locking the wheelchair. Do not connect any type of programming cable into this socket. This socket should not be used as a power supply for any other electrical device. Connection of other electrical devices may damage the control system or affect the E.M.C. performance of the wheelchair.)

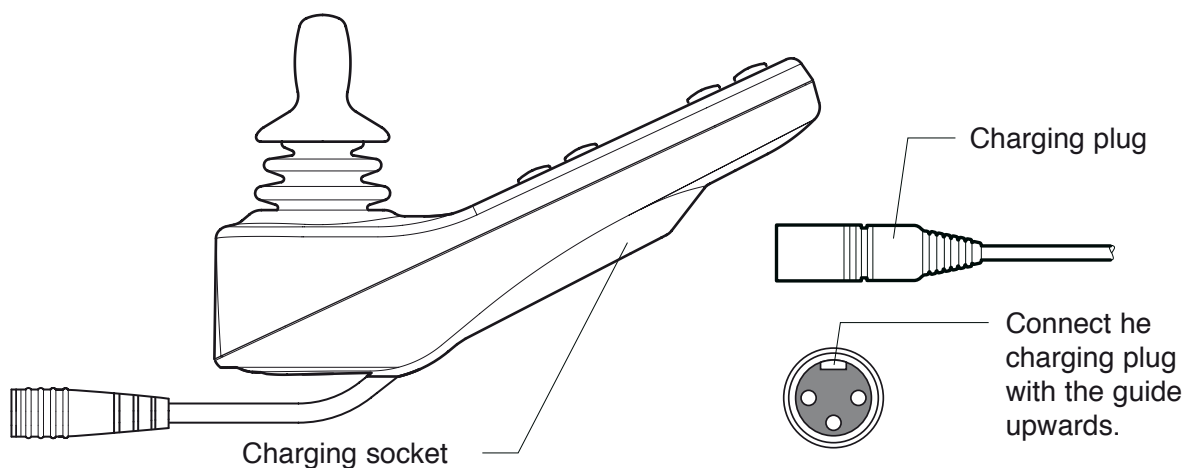

⚠ WARNING!

The wheelchair's warranty will be voided if any device other than a battery charger supplied with the wheelchair, or the lock key is connected into the control panels charger socket.

R-Net control panel LCD color display

Function Buttons

On the control panel there are a total of 10 Function Buttons.

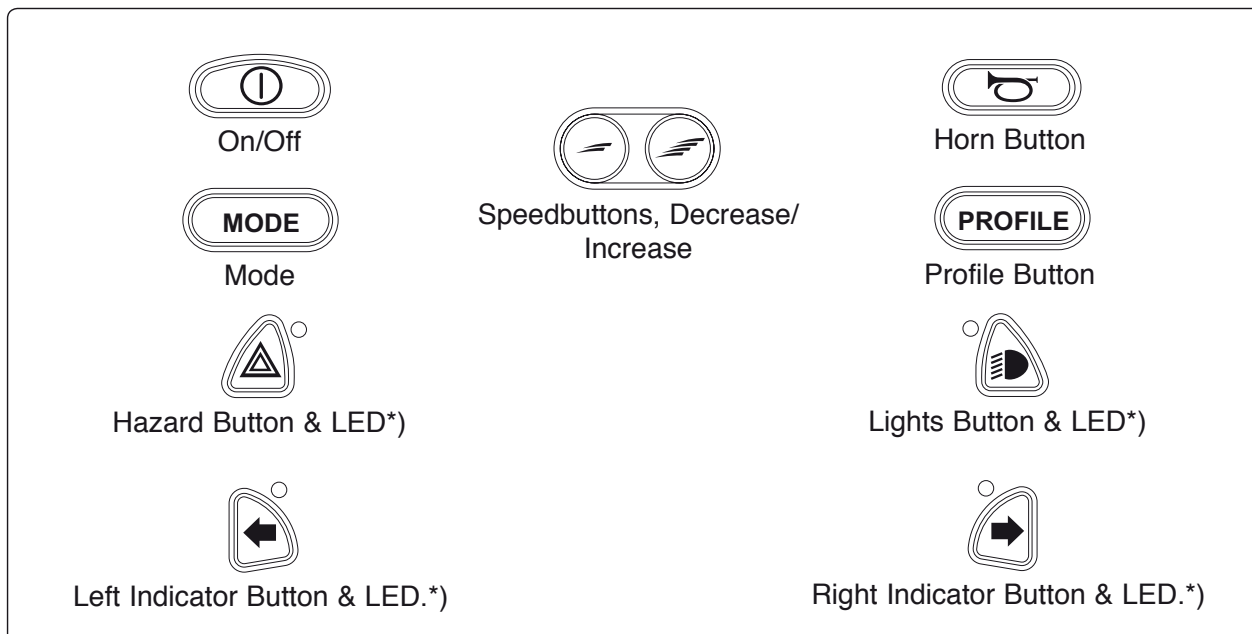

*) Only active if the wheelchair is equipped with lights.

On/Off Button

The On/Off button applies power to the control system electronics, which in turn supply power to the wheelchair's motors.

WARNING!

Do not use the On/Off Button to stop the wheelchair unless there is an emergency. If you do, you may get thrown out of the chair or shorten the life of the wheelchair drive components.

Horn Button

The horn will sound while this button is depressed.

Maximum Speed Buttons

These buttons decrease/increase the wheelchairs maximum speed. Depending on the way the control system has been programmed a momentary screen may be displayed when these buttons are pressed.

R-Net control panel LCD color display

Mode Button

The Mode button allows the user to navigate through the available operating Modes for the control system. The available modes are dependant on programming and the range of auxiliary output devices connected to the control system.

Profile Button

The profile button allows the user to navigate through the available Profiles for the control system. The number of available Profiles is dependant on how the control system is programmed. Depending on the way the control system has been programmed a momentary screen may be displayed when the button is pressed.

Hazard Warning Button and LED*)

This button activates/deactivates the wheelchairs hazards lights. This function is used when the wheelchair is positioned in a way making it an obstruction for others. Push the button to activate the hazard lights and push it again to deactivate them. When activated the indicator LED will flash in sync with the wheelchair's indicators.

Lights Button and LED*)

This button activates and deactivates the wheelchair's lights. Depress the button to turn the lights on and depress the button again to turn them off. When activated the lights LED will illuminate.

Left Indicator Button and LED*)

This button activates and deactivates the wheelchair's left indicator. Depress the button to turn the indicator on and depress the button again to turn it off. When activated the left indicator LED will flash in sync with the wheelchair's indicator.

Right Indicator Button and LED*)

This button activates and de-activates the wheelchair's right indicator. Depress the button to turn the indicator on and depress the button again to turn it off. When activated the right indicator LED will flash in sync with the wheelchair's indicator.

*)Only active if the wheelchair is provided with lights.

R-Net control panel LCD color display

External On/Off Switch Jack

This allows the user to turn the control system on and off using an external ability switch, such as a buddy button.

External Profile/Mode Switch Jack

(This jack's function varies depending on the programming.)

This allows the user to select Profiles using an external ability switch, such as a buddy button.

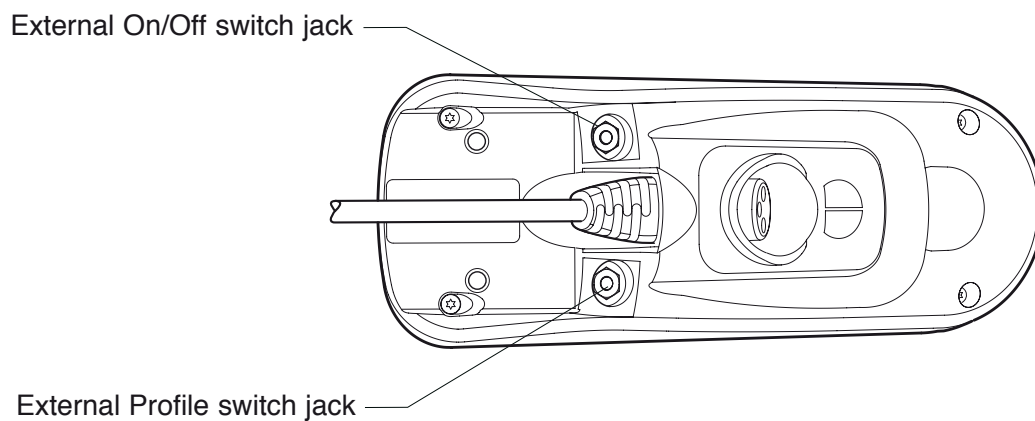

R-Net control panel LCD color display

Display

The status of the control system is shown in the display. The control system is on when the display is backlit.

Screen Symbols

The Drive screen for the R-net has common components, which will always appear, and components which will only appear under certain conditions. Below is a view of a typical Drive screen in Profile 1.

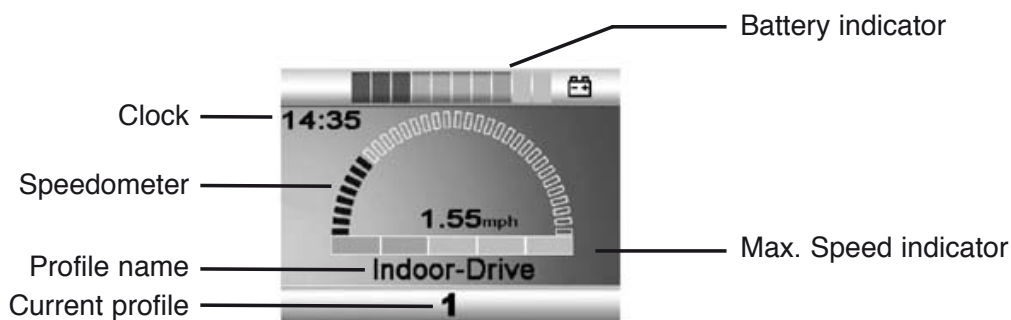

Battery Indicator

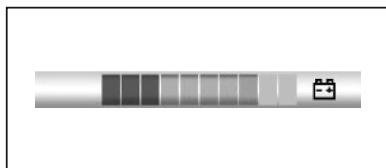

This displays the charge available in the battery and can be used to alert the user of the status of the battery.

Steady

This indicates that all is well.

Flashing Slowly

The control system is functioning correctly, but you should charge the battery as soon as possible.

Stepping Up

The wheelchair batteries are being charged. You will not be able to drive the wheelchair until the charger is disconnected and you have switched the control system off and on again.

R-Net control panel LCD color display

Speed Indicator

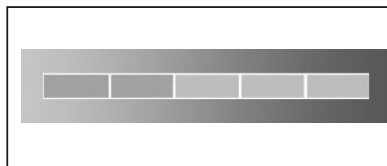

This displays the current speed setting.

The speed setting is adjusted using the Speed Buttons.

Current Profile

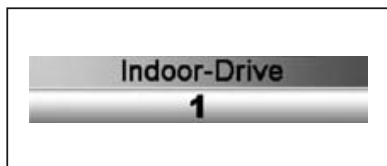

The Profile Number describes which Profile the control system is currently operating in. The Profile Text is the name or description of the Profile the control system is currently operating in.

In Focus



When the control system contains more than one method of direct control, such as a secondary Joystick Module or a Dual Attendant Module, then the Module that has control of the wheelchair will display the In Focus symbol.

Speed Limit

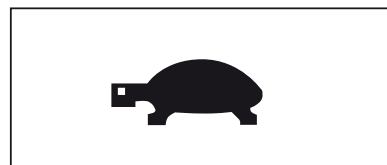

If the speed of the wheelchair is being limited; for example, by a raised seat, then this symbol will be displayed. If the wheelchair is being inhibited from driving, then the symbol will flash.

Restart



When the control system requires a restart; for example, after a module re-configuration, this symbol will be flashed.

R-Net control panel LCD color display

Motor Temperature

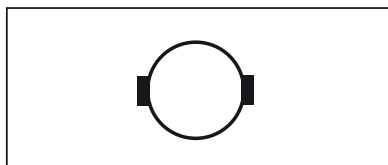

This symbol is displayed when the control system has intentionally reduced the power to the motors, in order to protect them against heat damage.

Control system Temperature

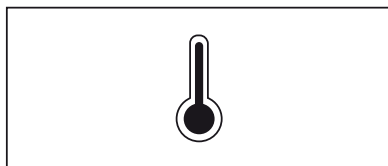

This symbol is displayed when the control system has intentionally reduced its own power, in order to protect itself against heat damage.

Timer



This symbol is displayed when the control system is changing between different states. An example would be entering into Programming Mode. The symbol is animated so that you can see the sand running through the hourglass.

E-Stop



If the control system is programmed for latched operation, then it is normal for an Emergency Stop Switch to be connected into the External Profile Switch Jack. If the Emergency Stop Switch is operated or disconnected, this symbol will flash.

R-Net control panel LCD color display

Installation menu

The installation menu permits the user to set the clock, the display brightness, background color etc. Access the menu by holding down the keys for higher and lower maximum speed simultaneously. Scroll through the menu by moving the joystick up or down.

Exit the installation menu by first selecting "Exit" at the bottom of the menu and then moving the joystick to the right.

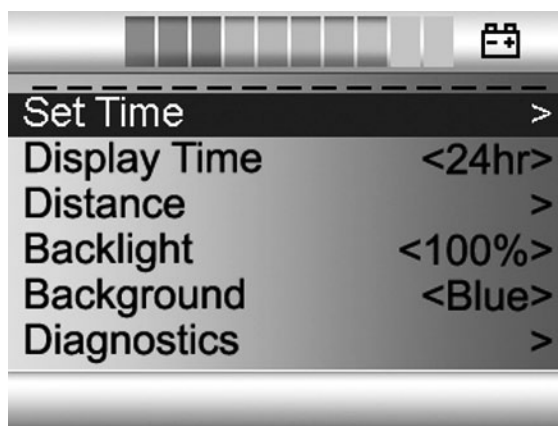

Setting the time (Set Time)

Select "Set Time" in the menu. Move the joystick to the right to go to the menu for setting the time. Then select "Year", "Month", "Date", "Hours" and "Minutes" by moving the joystick left or right. Set the desired value by moving the joystick up or down. Exit the installation menu by selecting "Exit" and then moving the joystick up or down.

Displaying the time (Display Time)

Select "Display Time" in the menu. Move the joystick right or left to select 12 or 24 hour display, or "Off" to remove the clock from the display.

Control panel R-Net LCD color display

Distance measurement (Distance)

Select "Distance" in the menu. Move the joystick to the right to go to the menu for setting distance measurement. Then select "Total distance", "Trip", "Distance display" or "Reset" by moving the joystick up or down.

- **Total distance** (Total Distance): Shows the total distance traveled by the control system.
- **Trip** (Trip Distance): Shows the total distance traveled since the last reset.
- **Distance display** (Display Distance): Selects Trip or Total Distance in the display.
- **Reset** (Clear trip distance): Move the joystick to the right to reset the Trip measurer.
- **Exit** (Exit): Move the joystick to the right to exit the installation menu.

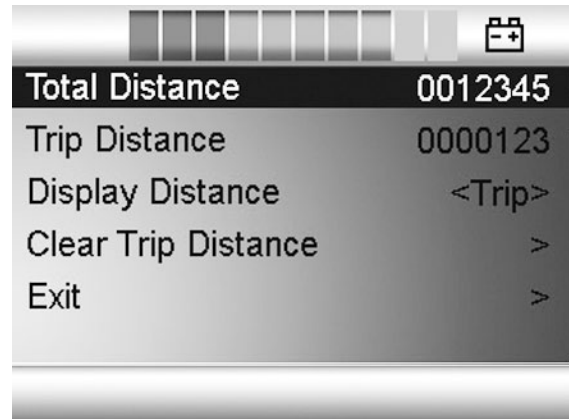

Brightness (Backlight)

Select "Backlight" in the menu. Move the joystick to right or left to set the desired brightness for the display backlight. Ten fixed levels are available from 10-100%.

Background (Background)

Select "Background" in the menu. Move the joystick right or left to select "Blue", "White" or "Auto".

- **Blue** (Blue): The display background is blue in all profiles.
- **White** (White): The display background is white in all profiles.
- **Automatic** (Auto): The display background is programmed in the various travel profiles. E.g. blue background for slow profile for indoors travel and white background for rapid profile for outdoors travel.

Diagnostics (Diagnostics)

For qualified technicians only.

R-Net control panel LED

General

The Control Panel consists of a joystick, function buttons and a display. At the front of the panel is the Charger Socket. Two Jack Sockets are located on the bottom of the panel.

Your wheelchair may also be equipped with a Seat Control Panel in addition to the control panel.

Control Panel Overview



R-Net control panel LED

Charger Socket

This socket should only be used for charging or locking the wheelchair. Do not connect any type of programming cable into this socket. This socket should not be used as a power supply for any other electrical device. Connection of other electrical devices may damage the control system or affect the E.M.C. performance of the wheelchair.)

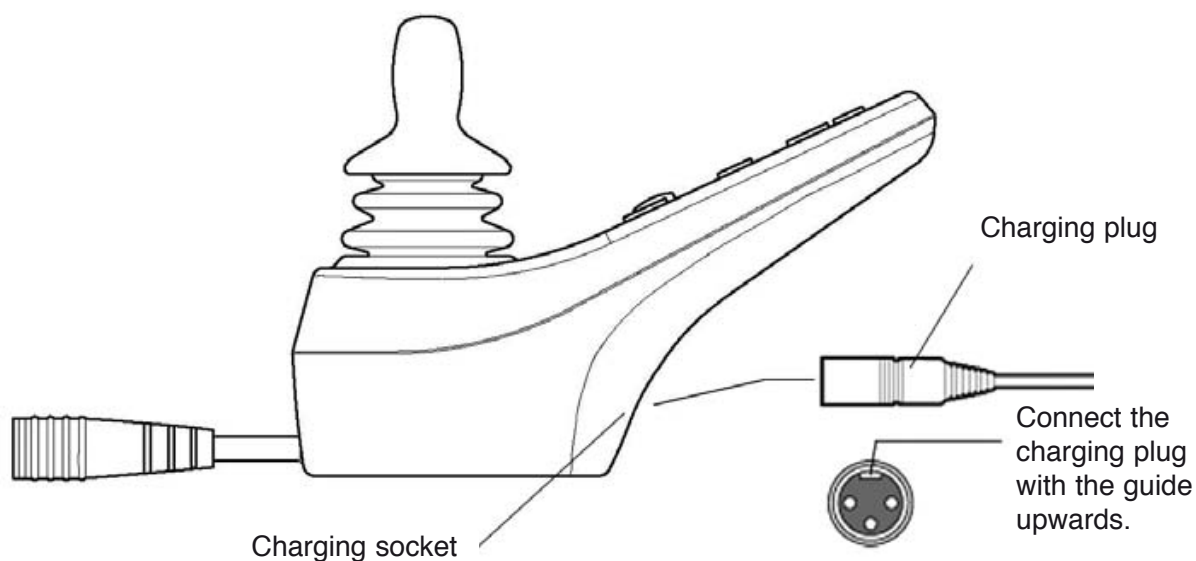

⚠ WARNING!

The wheelchair's warranty will be voided if any device other than a battery charger supplied with the wheelchair, or the lock key is connected into the control panels charger socket.

R-Net control panel LED

Function keys

There are a total of 9 function keys on the control panel with LEDs.

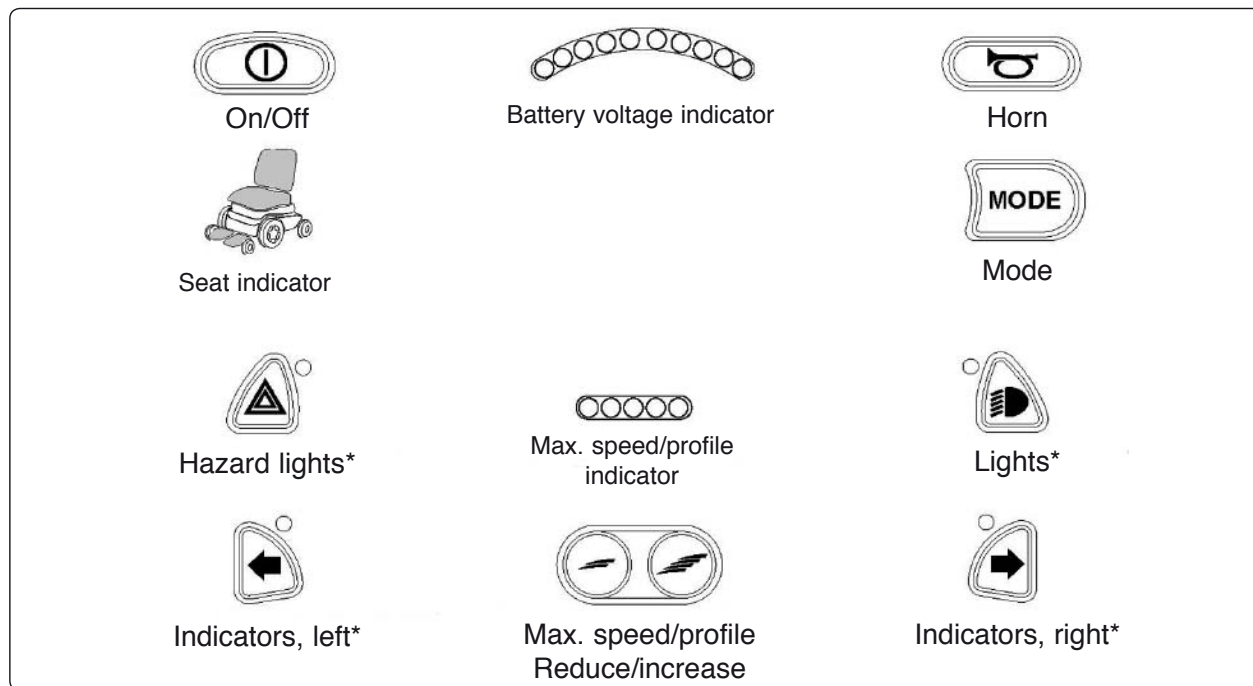

* Applies only if the wheelchair is fitted with lights.

On/off key

The on/off key is the switch for the control system's electronics which, in turn, supply power to the wheelchair's motors.

⚠ WARNING!

Do not use the On/Off Button to stop the wheelchair unless there is an emergency. If you do, you may get thrown out of the chair or shorten the life of the wheelchair drive components.

Horn

Pressing the switch produces a sound signal for attracting attention.

Max. speed/choice of profile

These keys normally reduce or increase the wheelchair's maximum speed. In special applications, the keys can instead control the choice of driving profile.

R-Net control panel LED

Mode

With the Mode key the user can scroll between the control system's available operating modes. The available modes depend on the programming and on which other output devices are connected to the control system.

Hazard lights*)

This key activates and deactivates the wheelchair's hazard lights. Hazard lights are used when the wheelchair is stationary in a position which may represent a risk or an obstacle for others. Press this key to activate the hazard lights. Press it again to deactivate them. When the hazard lights are active, the indicator lamp next to the control key flashes in time with the wheelchair's direction indicators.

Lights*

This key activates and deactivates the wheelchair's lights. Press this key to switch on the lights. Press it again to switch them off. When the lights are activated, the indicator lamp next to the control key also lights up.

Indicators, left*

This key activates and deactivates the wheelchair's left-hand direction indicators. Press the key to activate the indicators. Press it again to deactivate them. When the indicators are active, the indicator lamp next to the control key flashes in time with the wheelchair's left-hand direction indicators.

Indicators, right*

This key activates and deactivates the wheelchair's right-hand direction indicators. Press the key to activate the indicators. Press it again to deactivate them. When the indicators are active, the indicator lamp next to the control key flashes in time with the wheelchair's right-hand direction indicators.

* Applies only if the wheelchair is fitted with lights.

R-Net control panel LED

Battery voltage indicator

Shows the voltage remaining in the batteries (from left to right):

Red+Yellow+Green = Fully charged
Red+Yellow = Half charged
Red = Charge the batteries

A good way of using this indicator is to learn how it works while you are driving. Like a fuel gage in a car, it does not show exactly how much “fuel” is left, but it gives you a rough idea so that you can avoid unnecessary stops due to discharged batteries.

The indicator shows a more exact value after approximately 1 minute of travel.

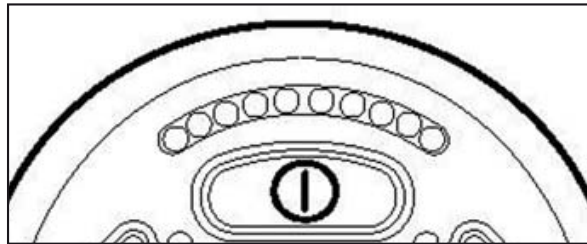

⚠ CAUTION!

The battery voltage indicator also functions as a “fault indicator” for the wheelchair’s electronics. See page 106 for further information.

R-Net control panel LED

Max. speed indicator

Speed

Indicates the maximum speed set for the wheelchair.

- 1 - 2 lamps = Low speed
- 3 - 4 lamps = Average speed
- 5 lamps = Max. speed

Driving profile

For special applications, the wheelchair can be programmed with more than one driving profile. In this case, the indicator's LEDs will instead display the selected driving profile. There can be up to 5 driving profiles.

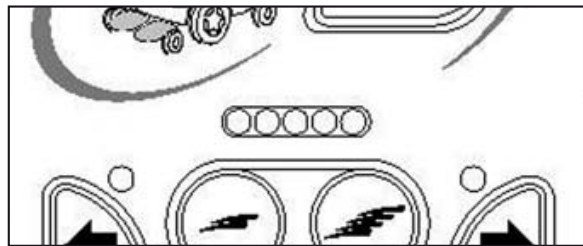

CAUTION!

The indicator for max. speed/driving profile also functions as a “fault indicator” for the wheelchair’s electronics. See page 106 for further information.

R-Net control panel LED

Seat indicator

On certain seats the electrical functions for seat lift, seat angle, backrest angle and legrest angle are controlled with the control panel joystick. In this case the active seat function is indicated on the control panel seat indicator.

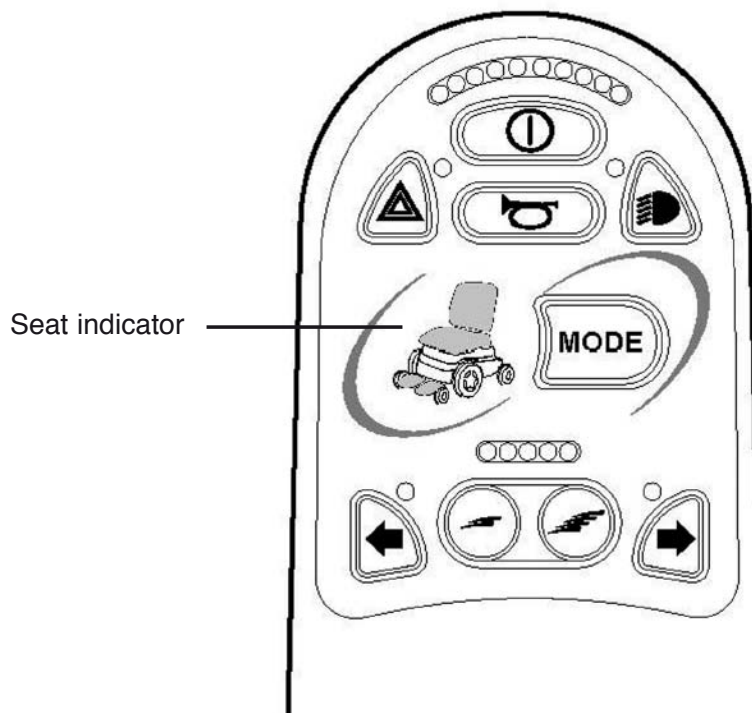

Handling

General

The Permobil M400 is designed for indoor and outdoor use. When driving indoors, you must observe care when driving in, for example, narrow passageways, when passing through doors and entries, as well as, when using elevators, ramps, etc. Also be conscious of the risk of pinching and/or crushing when you use the electrical seat lift and other seating functions, in particular when the wheelchair has been run in under a table, workbench or the like.

Outdoors, you must remember to drive very slowly on steep downhill slopes and to observe great care when driving on uneven surfaces, on uphill slopes, with sideways slopes and when negotiating obstacles. Always maintain a safe distance from the edge when driving close to drop-offs and precipices and drive using the lowest speed possible for the terrain.

We recommend that you make repeated test drives in surroundings in which you know you feel secure so that you are quite familiar with how the wheelchair and its accessories behave in different situations before you begin using the wheelchair in public areas.

Driving - General

Make sure that the control system is mounted securely and that the joystick position is correct. The body part that you use to operate the joystick should be supported, for example by the wheelchair arm pad. Do not use the joystick as the sole support for your hand or limb - wheelchair movements and bumps could upset your control. Make sure the wheel lock release lever is fully pushed into the chassis (wheel locks NOT released).

1. Switch on the power by pressing the start button on the control panel.

2. **Choose profile - VR2 Control system**

The control system is normally not programmed with more than one profile, but in special applications this can occur. In these cases choose a suitable profile with the profile/maximum speed button, see page 32.

Choose profile - R-net Control system

Choose a suitable profile with the profile button (if the control system is programmed with more than one profile), see page. 40.

3. Carefully move the joystick forward to drive forward, and backward to drive backward.

4. The speed of the wheelchair is adjusted continuously by the joystick being moved different distances forward and backward respectively. The wheelchair's electronics allow very slow driving over edges (max. 2.75 in. You can drive up to the edge, and then carefully drive over it.

Joystick Error - VR2 Control System

If the joystick is pushed before or just after the control system is turned on, the battery indicator will ripple up and down and the wheelchair will not be allowed to move. The joystick has to be released to resume normal operation. If the joystick is not released within 5 seconds the wheelchair will not be able to move, even if the joystick is released. The battery indicator will then flash rapidly. Reset this condition by switching the control system off and on again.

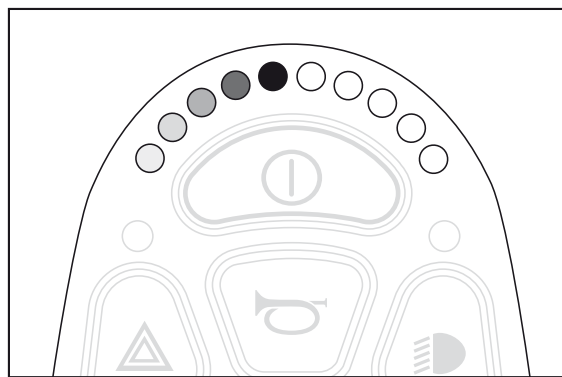

Battery indicator will ripple up and down

If the wheelchair still can't be driven and the battery indicator is flashing rapidly after restarting it, a problem somewhere in the wheelchair's electrical system has been detected. See further information in the section "Troubleshooting" on pages. 102-103, 108.

Joystick Error - R-Net Control System

If the joystick is moved from the central position before, during or immediately after the control system is switched on, the screen image for a shifted joystick will be displayed for 5 seconds. On control panels without a display, the LEDs on the battery voltage indicator will “wander” backwards and forwards instead. If the joystick is not released during this time, a joystick error will be registered and the wheelchair will not drive. To enable the wheelchair to drive again, ensure that the joystick is in the central position. Then switch the wheelchair off and on again.

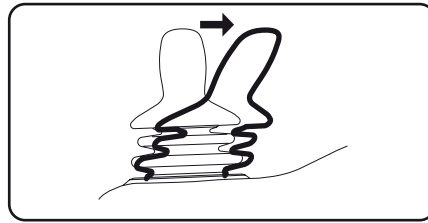

Screen image: Shifted joystick

If R-Net detects an error in the wheelchair electronics which needs attention, a “Diagnostics screen” will appear on control panels with display. See example below. On control panels without display, the battery voltage indicator LEDs will flash rapidly instead. If this happens, you should get in touch with your service contact as soon as possible.

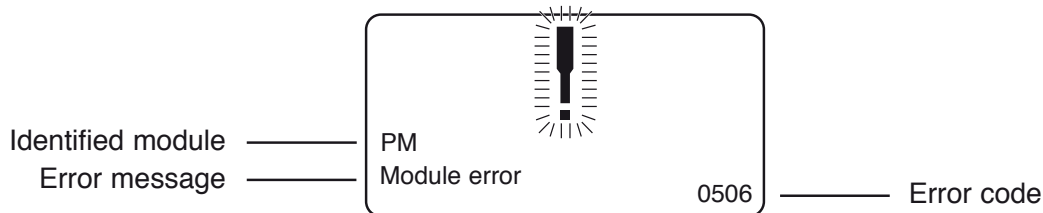

Screen: Diagnostics screen on monochrome display

Driving Technique

The control system electronics “interpret” the movements of the joystick and move the wheelchair as intended. For normal driving, the user doesn't need to employ any complex techniques, which is an advantage if the user is inexperienced. A good way of starting is quite simply to move the joystick in the direction you want to go. The wheelchair then moves in the direction in which the joystick is pointing. Always think about driving as flexibly as possible and avoid severe braking and avoidance maneuvers.

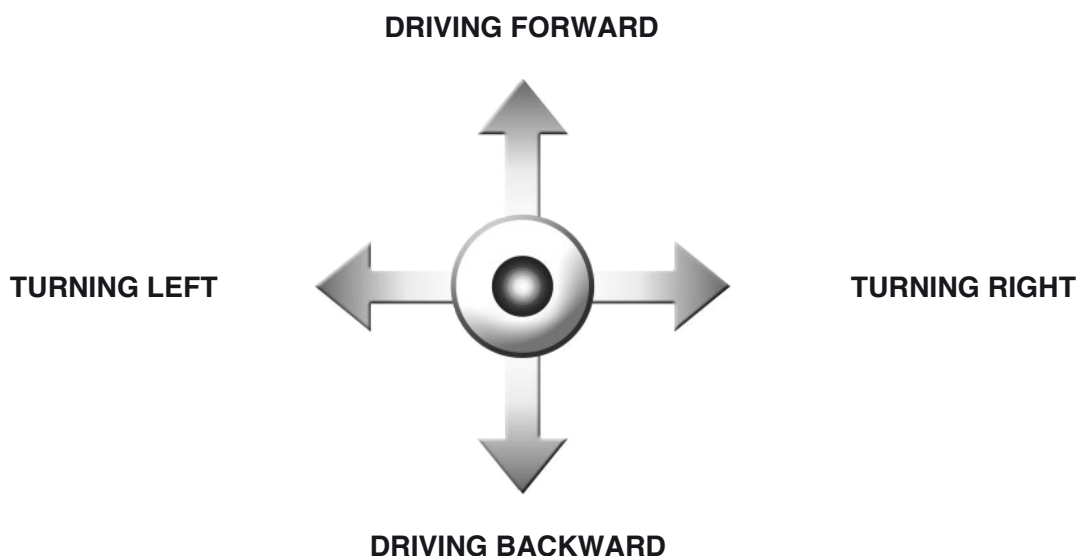

⚠ CAUTION!

Do not perform the first test drive on your own. The test drive is just a check of how you and the wheelchair function together, and you may need some assistance.

Before driving, check that the wheel lock release lever is set in the drive position.

Avoid severe braking and avoidance maneuvers.

⚠ WARNING!

Do not use the joystick as the sole support for your hand or limb - wheelchair movements and bumps could upset your control

Always bear in mind that a high speed and extended braking distance entail an increased risk of accidents.

In the event of the wheelchair moving in an unexpected way, **RELEASE THE JOYSTICK!** This action should stop the wheelchair under any circumstances. In the case of an emergency, if the wheelchair continues to move after releasing the joystick, turn the wheelchair off by pressing the On/Off button.

R-Net control panel

Locking/unlocking the wheelchair

The control system can be locked in two different ways. Either by using a key sequence on the keypad or with a physical key. The method used depends on how the system has been programmed.

Locking with the keypad:

- Press and hold down the on/off key while the control system is active.
- After 1 second, the control system emits a beep. Release the on/off key.
- Move the joystick forwards until the control system emits a beep.
- Move the joystick back until the control system emits a beep.
- Release the joystick. You will hear a long beep.
- The wheelchair is now locked.

Control panels with display will now show the following screen:

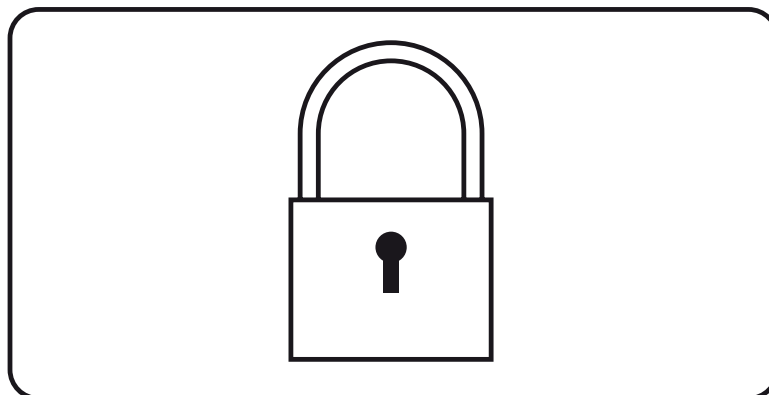

Unlocking:

- Press the on/off key if the control system is switched off. On control panels without display the LEDs on the speed indicator will “wander” backwards and forwards).
- Move the joystick forwards until the control system emits a beep.
- Move the joystick back until the control system emits a beep.
- Release the joystick. You will hear a long beep.
- The wheelchair is now unlocked.

R-Net control panel

Locking with a key

- Press the on/off key if the control system is switched off.
- Insert and remove the key from the charging contact on the control panel.
- The wheelchair is now locked.

Control panels with display will now show the following screen:

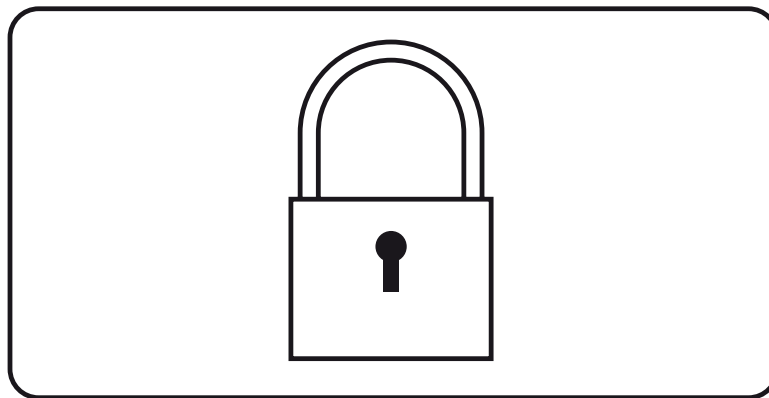

Unlocking:

- Press the on/off key if the control system is switched off. On control panels without display the LEDs on the speed indicator will “wander” backwards and forwards).
- Insert and remove the key from the charging contact.
- The wheelchair is now unlocked.

Seat functions - R-net electronics

(Not applicable to all seat models)

On some seats the electrical functions can be controlled with the help of the control panel joystick. Some models are equipped with three memory locations. Each memory location can store the position of the seat's adjustment device. This means that it is easy to retrieve a seat position saved earlier.

Maneuvering the seat

1. Press the "Mode" button one or more times until an icon for seat function appears in the control panel display - see illustration.
2. Move the joystick to the left or right to select a seat function. The icon for the seat function selected appears in the display.
3. Move the joystick forwards or backwards to activate the function.

Below is an example of the icons that may be shown in the display. Which icons are shown varies depending on the seat model and available functions.



Seat function activated.

CAUTION!

If the symbol "M" appears together with the seat icon, this means that a memory function has been activated. Move the joystick to the left or right to choose a seat function instead.

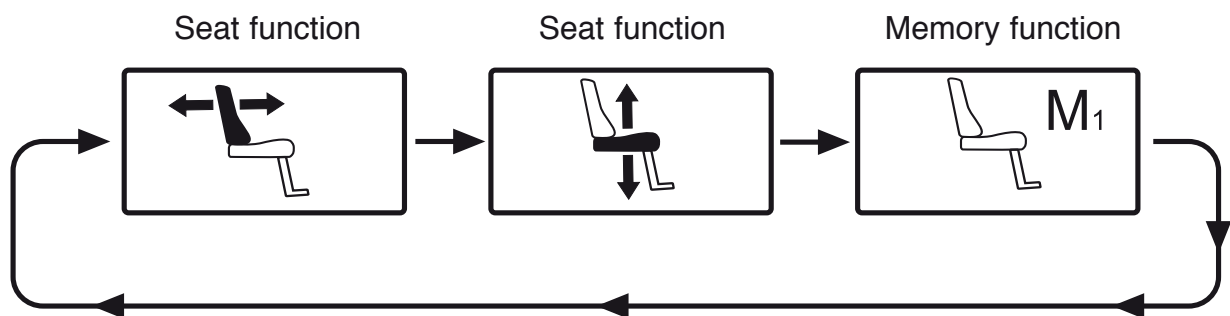

*Move the joystick to the left or right to select a function.
The icon for the function selected appears in the display.*

Seat functions - R-net electronics

(Not applicable to all seat models)

Return to drive mode

Press the "Mode" button one or more times until a standard display image with speed indicator appears in the control panel display - see illustration.



Standard display image with speed indicator.

Seat functions - R-net electronics

(Not applicable to all seat models)

The control system on some seats has three memory locations for seat positions. Each memory location can store the position of the seat's adjustment device. This means that it is easy to retrieve a seat position saved earlier.

Retrieving position from memory

1. Press the "Mode" button one or more times until a seat icon appears in the control panel display.
2. Move the joystick to the left or right to select a memory location (M1, M2 or M3). A seat icon and memory symbol "M" for the memory location selected are shown in the control panel display - see illustration.
3. Move and hold the joystick forwards. The seat adjusts to the position stored earlier. For reasons of safety, the joystick must be held forwards until the seat is fully adjusted to the required position. Once the seat has adjusted to the saved position, it stops moving.

CAUTION!

Movement of the seat can be stopped at any time by releasing the joystick.

Return to drive mode

Press the "Mode" button one or more times until a standard display image with speed indicator appears in the control panel display - see illustration.



Memory function activated.



Seat functions - R-net electronics

(Not applicable to all seat models)

Saving position to memory

1. Set the seat's electrical functions to the desired mode.
2. If not activated, activate the seat/memory function by pressing the "Mode" button one or more times until a seat icon appears in the control panel display.
3. Move the joystick to the left or right to select a memory location (M1, M2 or M3). A seat icon and memory symbol "M" for the memory location selected are shown in the control panel display - see illustration.



Memory function activated.

4. Move the joystick backwards to activate the "save" function. An arrow will appear next to the memory symbol "M" - see illustration.
5. Save the current position by moving the joystick forwards and holding it in that position until the arrow next to the memory symbol "M" disappears.

Return to drive mode

Press the "Mode" button one or more times until a standard display image with speed indicator appears in the control panel display - see illustration on previous page.



Save function activated.

Seat functions R-Net LED

(Not applicable to all seat models)

On certain seats the electrical functions for seat lift, seat angle, backrest angle and legrest angle are controlled with the control panel joystick. Other seat functions require a separate seat control panel.

Maneuvering the seat

1. Press the "Mode" button one or more times until the LED for a seat function lights up.
2. Move the joystick to the left or right to select a seat function. The LED for the selected seat function will light up.
3. Move the joystick forwards or backwards to activate the function.



Seat indicator

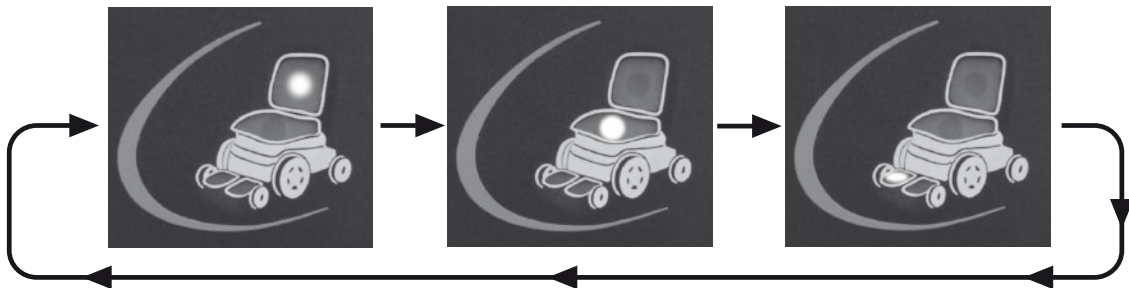

*Move the joystick to the left or right to select a function.
The LED for the selected function will light up.*

Seat functions R-Net LED

(Not applicable to all seat models)

Return to drive mode

Press the "Mode" button one or more times until a standard display image with speed indicator appears in the control panel display - see illustration.

Driving Rules

WARNING!

Always bear in mind that high speed and extended braking distance entail an increased risk of accidents.

Never drive rapidly or at full speed along narrow passages, on narrow sidewalks, etc. where an incorrect maneuver or incorrect steering can cause an increased risk of accidents.

Always drive at low speed on uneven surfaces.

Keep in mind that driving across slopes will have an effect on the wheelchair and could make it steer to the side. Never drive at full speed across slopes.

Use of the seat lift, backrest/seat tilt function changes the wheelchair's center of gravity, which can have a negative effect on the wheelchair's handling characteristics while it is being driven. You should never drive at full speed when the seat lift is elevated, or when the seating system has an extreme backrest angle or tilt angle.

You must be extremely careful and drive at slow speed when driving downhill or uphill on an uneven surface, for example, grass, gravel, sand, ice and snow. Failure to do so may result in personal injury and/or damage to the wheelchair.

Driving Rules

Driving over Obstacles

Do not drive the wheelchair over obstacles of a height greater than 3 inches. Driving over tall edges increases the risk of tipping over as well as the risk of damage to the wheelchair.

Negotiating obstacles must always be done with great care

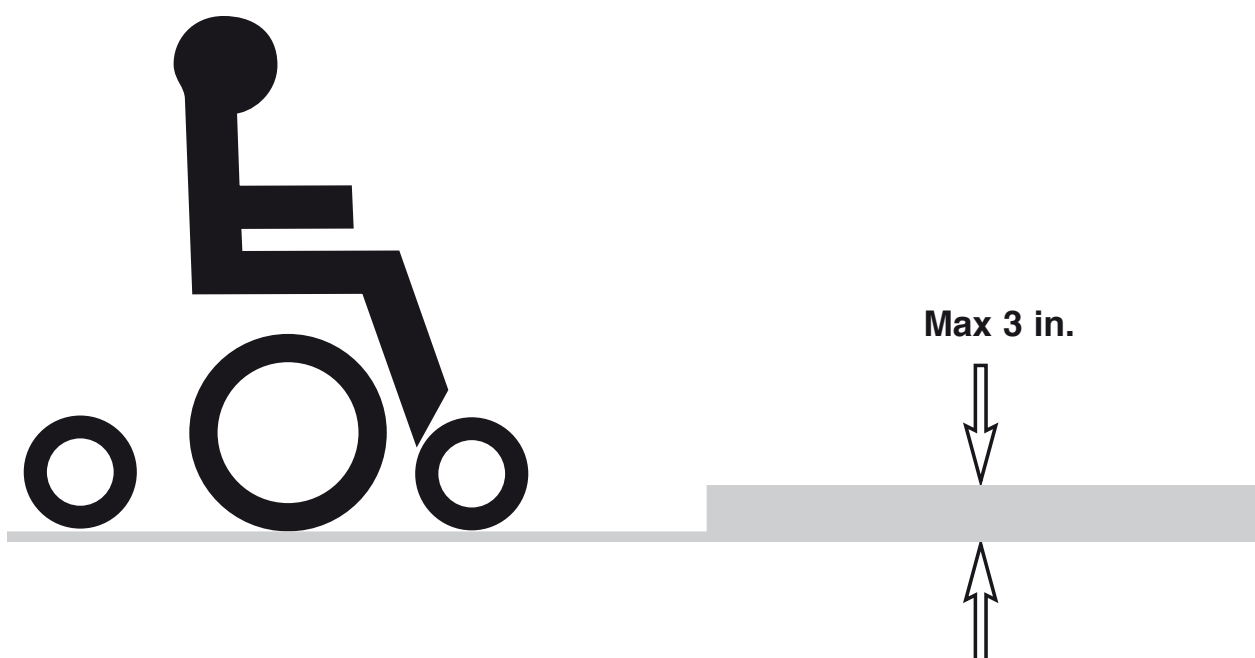

⚠ WARNING!

Do not drive the wheelchair over obstacles of a height greater than 3 inches. Negotiating obstacles must always be done with great care.

⚠ WARNING!

Operating the seat lift, seat tilt and/or backrest recline changes the center of gravity and increases the risk of tipping over, hence those seat functions shall only be used on level ground, driving in low speed with great caution.

Driving downhill

You should always drive downhill at low speed and with great caution.

Avoid braking suddenly and sudden evasive maneuvers and never drive so fast that you are unable to control the wheelchair safely without risks.

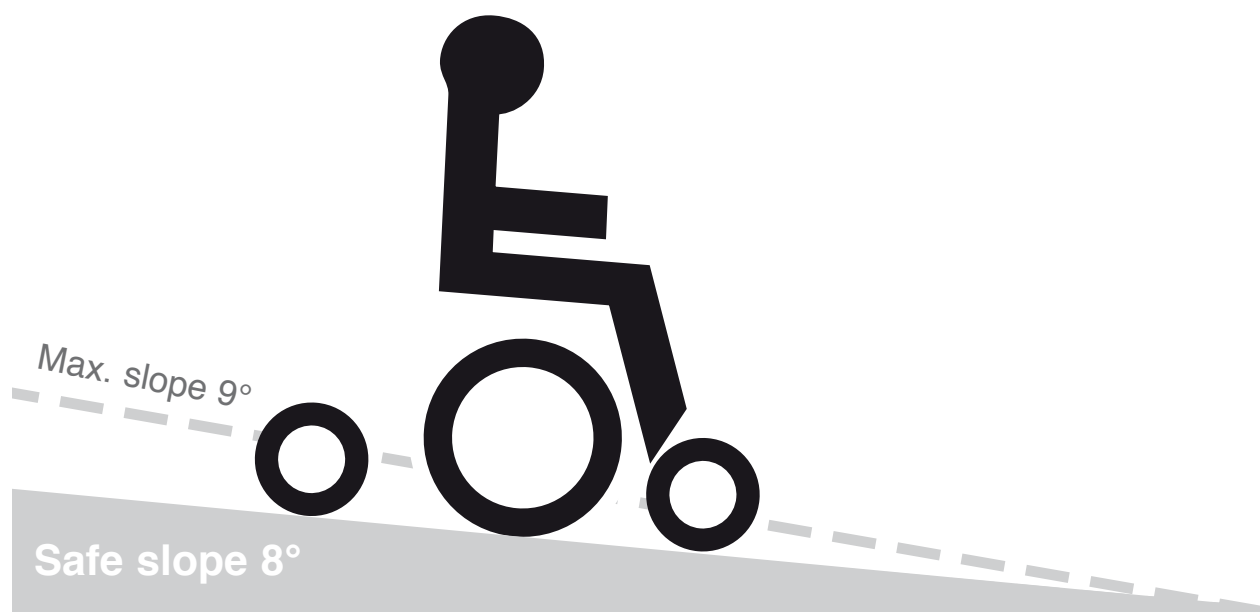

⚠ WARNING!

Do not drive downhill on a gradient greater than 8°.
Dynamic stability according to ISO 7176-2 = 6°.

⚠ WARNING!

You should be extremely careful when driving downhill on an uneven surface (for example grass, gravel, sand, ice and snow). Failure to do so may result in personal injury and/or damage to the wheelchair.

A raised seat lift/seat angle/back angle changes the center of gravity and increases the risk of tipping. Therefore, use these seat functions only on flat surfaces and always drive with great caution and at low speed.

Driving uphill

You should always drive uphill with great caution.

Avoid sudden evasive maneuvers and never drive so fast that you are unable to control the wheelchair safely without risks.

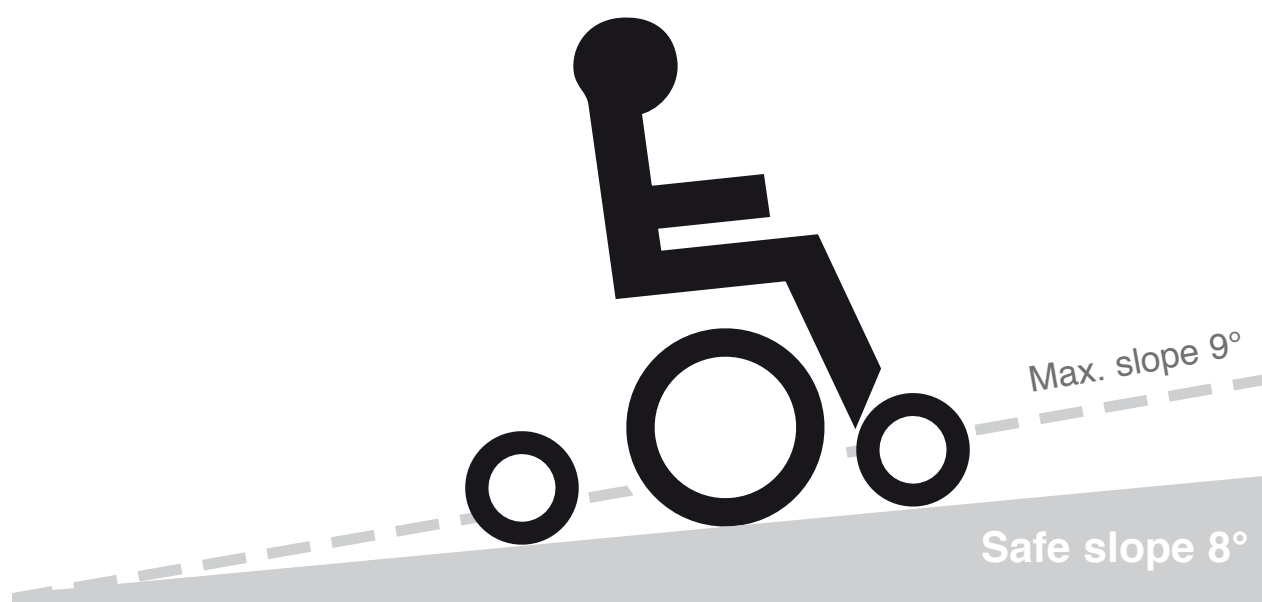

⚠ WARNING!

Do not drive uphill on a gradient greater than 8°. Dynamic stability according to ISO 7176-2 = 6°.

⚠ WARNING!

You should be extremely careful when driving uphill on an uneven surface (for example grass, gravel, sand, ice and snow). Failure to do so may result in personal injury and/or damage to the wheelchair.

A raised seat lift/seat angle/back angle changes the center of gravity and increases the risk of tipping. Therefore, use these seat functions only on flat surfaces and always drive with great caution and at low speed.

Driving on Sideways Slopes

Driving on a sideways slope must always be performed with great care.

Avoid abrupt avoidance maneuvers and never maintain a speed higher than that at which you can maneuver the wheelchair in a safe and secure manner.



⚠ WARNING!

Do not drive the wheelchair on sideways slopes of greater than 9 degrees. There is a risk of tipping over.

⚠ WARNING!

When driving on sideways slopes with an uneven surface (for example grass, gravel, sand, ice or snow) a great deal of extra care must be observed. Failure to do so may result in personal injury and/or damage to the wheelchair.

A raised seat lift/seat angle/back angle changes the center of gravity and increases the risk of tipping. Therefore, use these seat functions only on flat surfaces and always drive with great caution and at low speed.

Manual Release of the Magnetic Wheel Locks

The wheelchair is fitted with a manual brake release on each drivewheel that can be released to make it possible to move the wheelchair manually. The brake release levers are located at the front of the wheelchair.

Release the wheel locks

1. Shut off the wheelchair using the start button on the control panel.
2. Move the levers outwards to release the brakes. The chair can now be moved manually.

Engage the wheel locks

Move the lever inwards so that it assumes in its innermost position. Always check that the release lever goes right to its most inner position.



Location of the release levers.



Wheel lock released.

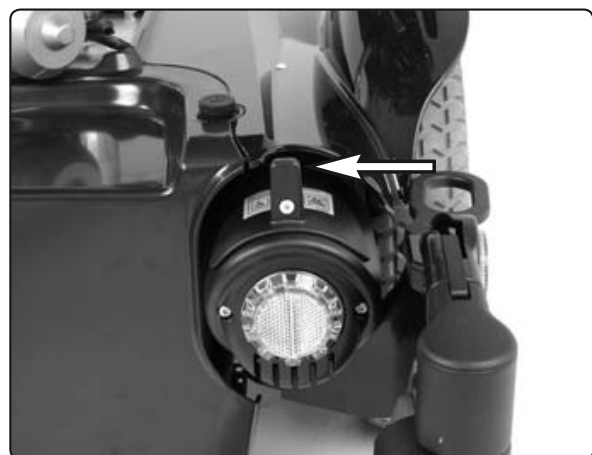

Wheel lock engaged.

⚠ WARNING!

Do not engage or disengage the wheel locks unless power to the chair is off.

In order to avoid the wheelchair rolling away, ensure that the wheelchair is on a level and dry surface before releasing the wheel locks.

Be aware that the chair will not have brakes when the wheel locks are in the free-wheel position.

Make sure that the person pushing the chair has full control when the wheel locks are disengaged.

Always reset the wheel lock release after manually moving the wheelchair.

⚠ CAUTION!

When the wheel locks are released, the chair will not drive. If it does, contact an Authorized Permobil service center as soon as possible.

Battery Charging

The amount of charge in your batteries depends on a number of factors, including the way you use your wheelchair, the temperature of the batteries, their age and the way they are made. These factors will affect the distance you can travel in your wheelchair between charging the batteries. All wheelchair batteries will gradually lose their capacity as they age.

The most important factor that reduces the life of your batteries is the amount of charge you take from the batteries before you recharge them. Battery life is also reduced by the number of times you charge and discharge the batteries.

To make your batteries last longer, do not allow them to become completely discharged. Always recharge your batteries promptly after they are discharged.

If your battery gauge reading seems to fall more quickly than usual, your batteries may be worn out.

CAUTION!

If the batteries should be drained completely, it is important that you charge them up again as soon as possible since a complete loss of charge reduces the lifespan of the batteries.

WARNING!

Observe care in the use of metallic objects when working with batteries. A short-circuit can easily cause an explosion. Always use safety gloves and protective eye-glasses.

Only chargers with a max 10 A charging current (average value) may be used.
(The RMS value of the charging current must not exceed 12A.)

Charging must be done in a well-ventilated room, not in a wardrobe or closet. Charging must not be done in a bathroom or wet room.

The charger's charging cable must not be extended.

The charger can become hot and hence must not have anything covering it. The charger must be positioned so that there is an air gap on all of its sides, including below (do not set the charger on thick carpeting, for example).

The charger contact must be replaced if it is damaged or becomes hot during charging. Both the contact on the charger's cord and the wheelchair's control panel should be replaced if one of them is damaged or worn. Replacement must be performed by qualified personnel.

Charging

Connect the charger plug into the battery charging socket on the control panel. The molded guide on the socket will help you to locate the plug.

Description and Use of Battery Charger, see supplied Owner's Manual.

⚠ CAUTION!

Ensure that the charger plug is pushed fully into position before turning on the battery charger. You will not be able to drive the wheelchair when the charger is connected. If the wheelchair does drive with the charger plugged in, contact an Authorized Permobil service center as soon as possible.

⚠ WARNING!

Only use the battery charger that has been supplied with your wheelchair or recommended by Permobil. The use of incorrect chargers could damage the batteries, wheelchair, control system or charger itself, or may result in parts overheating creating the potential for burns or even fire.

To avoid sparking and unnecessary wear and tear of the wheelchair's charging socket, be sure that the main voltage and the charger is in the OFF position when connecting/disconnecting the charging cable to the wheelchair's charging socket.

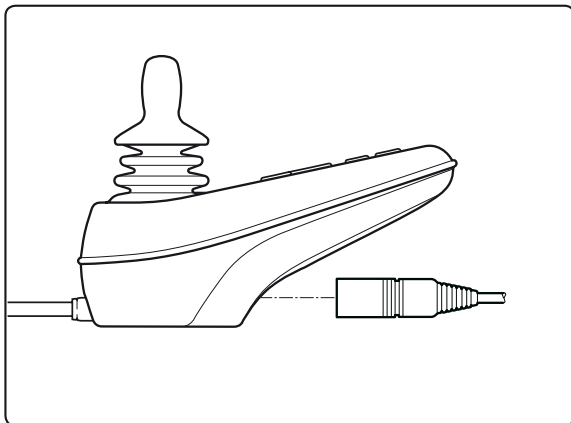

*Charging Socket
on the VR2 control panel.*

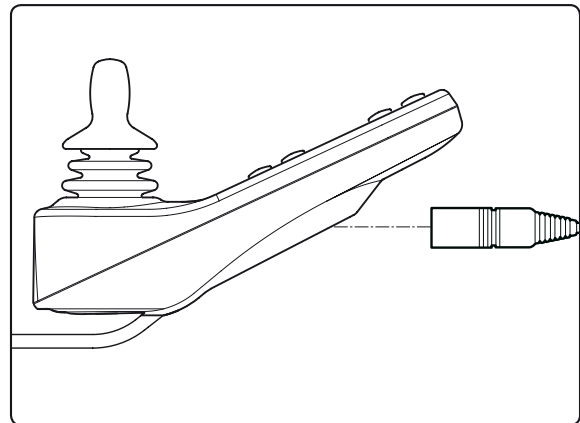

*Charging Socket
on the R-Net control panel.*

Transport

The wheelchair must only be transported in a vehicle that is approved for such purposes.

Check that the wheelchair is properly fastened and that the wheel locks are engaged. When transporting the wheelchair in a vehicle, the wheelchair must be locked into position by running fastening straps through the brackets in the front and the back, each marked with a yellow sticker.

Secure the wheelchair according to the manufacturer of the vehicle restraint systems instructions. Always make sure that the fastening points on the transport vehicle are well-anchored.



*Left Front Fastening
Bracket*

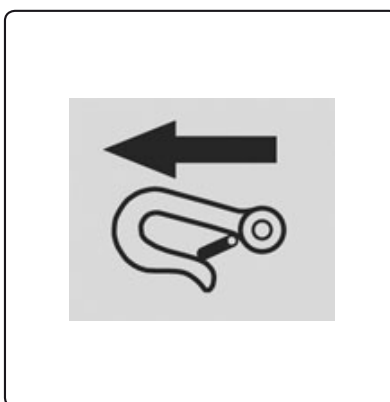

Sticker



*Right Rear Fastening
Bracket*

⚠ WARNING!

Use Prohibited in Motor Vehicles

Permobil recommends that users NOT be transported in any kind of vehicle while in their wheelchair, unless the user is in an approved Permobil wheelchair configuration, has secured the wheelchair using a Permlock C3, and is using a seatbelt attached to the vehicle. The only other safe alternative is that users be transferred into factory vehicle seating for transportation and use safety restraints made available by the auto industry. The only wheelchair transportation system Permobil recommends is a Permlock C3 used in combination with an approved Permobil wheelchair.

Unless using a Permlock C3 with an approved Permobil wheelchair, never sit in your wheelchair while in a moving vehicle. In an accident or sudden stop, you may be thrown from the chair and seriously injured or killed.

Permobil positioning belts are designed to position the user only and not to protect you in the event of a motor vehicle accident. The positioning belts do not replace use of a vehicle mounted restraint.

 WARNING!

If the wheelchair has to be transported with the user in the chair into the vehicle through a ramp, the wheelchair shall be secured against tipping backwards by a person behind.

Wheelchair users should transfer to the vehicle seat and use the vehicle-installed restraint system whenever it is feasible.

The vehicle restraint belt should not be worn twisted.

Always make sure that the vehicle restraint belt is not adjusted over sharp edges of the wheelchair.

The vehicle restraint belt should not be held away from the body by wheelchair components or parts, such as the wheelchair's armrest or wheels.

All wheelchair-mounted trays shall be removed and secured separately in the vehicle, or be secured to the wheelchair.

When possible, other auxiliary wheelchair equipment should be either secured to the wheelchair or removed from the wheelchair and secured in the vehicle during transit, so that it does not break free and cause injury to vehicle occupants in the event of a collision.

A poorly fastened chair can cause extensive damage and injury both to the people in the transport vehicle as well as to the vehicle itself and the wheelchair if it comes loose.

General Advice for Air transport

Please refer to the Air Carrier Access Act at 49 USC § 41705 and accompanying regulations at 14 CFR Part 382 for specific guidelines and regulations pertaining to transporting wheelchairs on aircraft in the United States.

Further guidelines on transporting powered wheelchairs and batteries can be found at the Department of Transportation hazardous materials regulations (49 CFR Parts 171, 172, 173, 175).

Due to the variance in aircraft sizes and cargo space dimensions, always contact the airline prior to traveling or purchasing a ticket to make sure that your Permobil can be accommodated.

When transporting your wheelchair by air, these three items must be considered:

1. Batteries

Gel batteries: In most cases they don't need to be taken out of the wheelchair.

If your wheelchair is equipped with a Main Fuse, the electrical connections to the batteries must be disconnected and insulated. If your wheelchair has a Circuit Breaker, make sure the Circuit Breaker is in OFF-position.

Acid batteries(liquid electrolyte): Most airlines require that the batteries be taken out of the wheelchair and that they must be transported in special boxes that the airline can provide.

2. The Dimensions and Weight of the Wheelchair

The weight and dimensions of the wheelchair are significant in relation to the type of airplanes in which the wheelchair is to be transported. Always check with the airline before traveling to make sure that the aircraft in question can accommodate your wheelchair.

CAUTION!

The weight and dimensions of the wheelchair listed in this manual are based on the most common configurations of the wheelchair. Wheelchairs which have had custom modifications or additional features may have different dimensions or weights. Be sure to measure the dimensions of your particular chair whenever exact dimensions are critical or required.

Certain airlines can refuse to take acid batteries on board.

General Advice for Air transport

3. Preventing Damages

The electronic components, as well as other critical parts, in your wheelchair are highly sophisticated and fragile and care must be taken to protect them.

When transporting your wheelchair by air, we recommend that you cover the control panel with soft, shock-absorbing material (foamed plastic or similar) and fold it in towards the center of the seat.

Protect other fragile parts in a similar fashion. Tape any loose cables to the seat frame or covers.

CAUTION!

In order to ensure that the transport can take place in a safe manner and that no unpleasant surprises arise at the last minute, you should always contact the respective airlines before the transport.

Maintenance and Repairs

To ensure that your wheelchair works well, you must inspect, maintain, and obtain routine service on it regularly. Every wheelchair is subject to wear and tear between the moving parts and also due to the strains and stresses of typical use. Therefore, you must know how the wheelchair works, how to use it correctly, and how to maintain it. Preventive maintenance will minimize the risk of component failure. If you look after your wheelchair, it will work well and the risk of faults will be reduced.

Tool Kit

A tool kit comes with the wheelchair and contains the following that can be used for performing maintenance and easier repairs.

| TOOL | AREA OF USE |
|--------------------------|---|
| Allen keys | General maintenance/seat adjustment |
| 10-11, 12-13 mm spanners | General maintenance/replacing batteries |
| Seat lift crank | Manually raising the seat lift |
| 2 Screwdrivers | General maintenance |

CAUTION!

Certain repairs can require tools other than those that come with the wheelchair.

The power switch on the control panel must always be shut off when batteries are replaced or when the electronics are being serviced.

WARNING!

Any inappropriate modifications to the wheelchair and its various systems may entail an increased risk of accidents. Carefully follow the recommendations in the Handling section to prevent the risk of accidents in connection with driving.

All modifications to and interventions in the vital systems of the wheelchair must be performed by a qualified service technician. Always contact a qualified service technician in cases of doubt.

General Batteries/Storage

- Note that a battery drains on its own and a discharged battery can freeze and burst when it is cold. If the wheelchair must be stored without being used for a long period of time, the batteries should always be charged up once per month so that they do not incur any damage.
- The wheelchair must not be stored in a room where condensation arises (mist or dampness on the surfaces) e.g. laundry rooms or similar rooms.
- The wheelchair can be stored in an unheated room. What is best for the wheelchair from a corrosion standpoint is that the room be some degrees warmer than its surroundings, which keeps the room drier.
- If the wheelchair is equipped with acid batteries(liquid electrolyte), the acid level should be checked regularly. If the wheelchair is equipped with GEL batteries, the fluid level need not be checked.
- The lifespan of the batteries depends entirely upon regular charging.

Short-term storage

In order for the charging procedure to give a battery with good capacity, the temperature in the storage room must not be lower than 41 F. Storage at under 41 F increases the risk of the battery not being fully charged when it is to be used as well as increasing the risk of corrosion.

Long-term storage

Storage can occur in an unheated room, however the battery should be maintenance-charged at least once per month.

WARNING!

Observe care in the use of metallic objects when working with batteries. A short-circuit can easily cause an explosion. Always use safety gloves and protective eye-glasses.

Maintenance and Repairs

With regular care and maintenance, your Permobil will provide years of superior performance and satisfaction. To maintain the finish quality of your wheelchair, please follow the cleaning procedures provided below.

The instructions for the care and maintenance of Permobil products are provided to you as a service. No warranty is implied since results may vary.

Vinyl Upholstery

For normal cleaning, wash vinyl upholstery with a soft cloth or soft-bristled brush lathered with mild, nonabrasive soap and lukewarm water. Before the surface dries, wipe with a clean, dry cloth to remove any residue. This procedure may be repeated to remove stubborn dirt or stains.

Ink spots can sometimes be removed by washing with soap and water followed by isopropyl alcohol.

Do not use any cleaning method that is not listed above, as other methods may attack the vinyl and cause eventual degradation.

Coated Metal

For normal cleaning, wash coated metal surfaces with a soft cloth soaked in detergent and warm water; rinse thoroughly and dry.

Remove scuff marks from low-gloss coatings with pre-softened paste wax, following the manufacturer's instructions.

Remove scuff marks and scratches from high-gloss coatings using automotive polishing compounds, either liquid or paste. After polishing, apply a pre-softened automotive paste wax to restore original sheen.

Plastic

For normal cleaning, wash plastic surfaces with a soft cloth soaked in mild detergent and warm water. Rinse thoroughly and dry with a soft cloth. Do not use solvents or abrasive kitchen cleaners.

WARNING!

Do not rinse the wheelchair off with a water hose, its electronics can be damaged. The wheelchair must always be shut off while it is being cleaned.

Maintenance and Repairs

Wheel Lock Release

Check regularly, approximately once per month, the functionality of the wheel lock release.

It must not be possible to drive the wheelchair when the wheel locks are disengaged. If the wheelchair is able to drive when the wheel locks are disengaged, contact an Authorized Permobil service center immediately.



Location of the release levers.

Maintenance and Repairs

Changing inner tube

1. Switch off the main power switch on the control panel.
2. Lift up and chock up the wheelchair chassis so that the wheel in question is free of the ground.
3. Remove the wheel, it's fitted with four screws.
4. Release the air.
5. Remove the six screws holding the two halves of the rim together.
6. Take the rim apart.

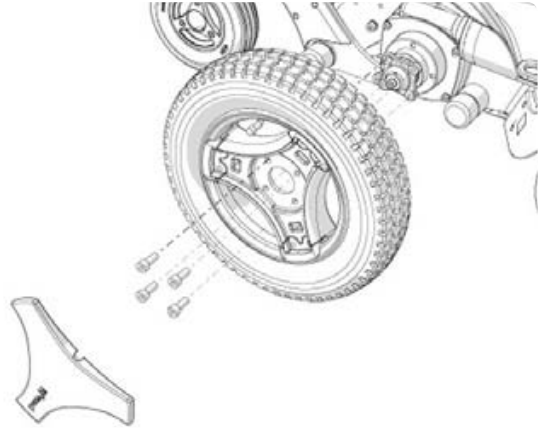

⚠ WARNING!

The central screw must not be removed.

Ensure that pneumatic tires are not pressurized before the rim is taken apart, otherwise there is a risk of personal injury.

7. Change the inner tube (2) in the tire (3) and fit together with the two rim halves (1&4). Tighten the six screws using a dynamometric wrench.
Tightening torque: 22 Nm.
8. Fill the tire to recommended tire pressure, 29 psi (200 kPa).
9. Fit the wheel on to the wheelchair. Tighten the four screws using a dynamometric wrench. **Tightening torque 24 Nm.**

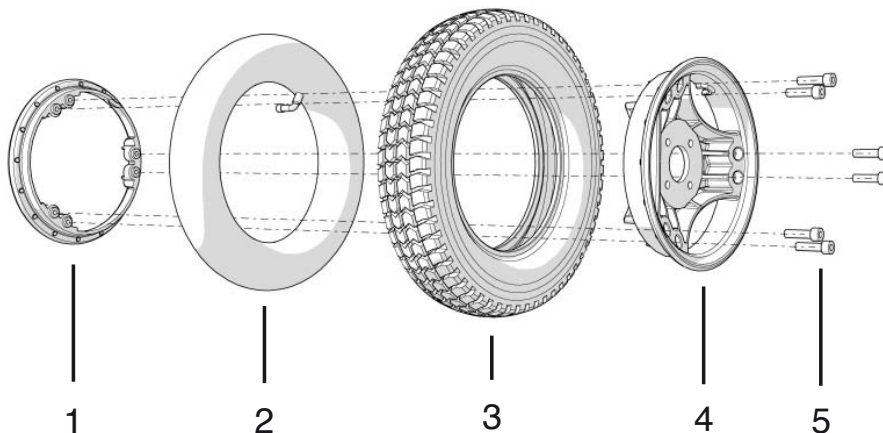

Maintenance and Repairs

Tire pressure

Check at regular intervals that the wheelchair's tires have the prescribed tire pressure. An incorrect tire pressure can cause deterioration in stability and maneuverability, plus extremely low air pressure can give rise to abnormal wear as well as shorter driving distances. So check regularly to see that the tires are maintained at a pressure of 29 psi (200 kPa).

Filling with air

1. Unscrew the plastic cap on the air valve of the tire.
2. Connect the compressed air nozzle to the air valve and adjust the tire pressure to the prescribed level.



Filling valve.

⚠ WARNING!

The recommended air pressure for the drive wheel tires is 29 psi (200 kPa). Overfilling causes a risk of explosion. Incorrect tire pressure can involve a deterioration of stability and maneuverability, so check regularly that the tire contains the prescribed air pressure.

Changing the batteries

Front battery

1. Place the wheelchair on a level surface.
2. Run/fold out the leg support and raise the seat lift.
3. Turn off the main power switch on the control panel.
4. Put the circuit breaker in the "OFF" position. It is accessed through a hole in the chassis cover; see fig.
5. Remove the two knobs holding the front cover. Remove the front cover by pulling it upwards/forwards.

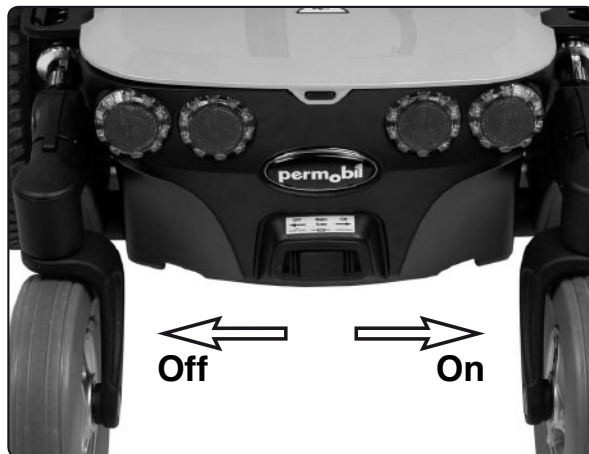

The circuit breaker is accessed through a hole in the chassis cover.



The front cover is fitted with two knobs.



Front battery.

Changing the batteries

Front battery

6. Loosen the battery holder strap, it's attached with hook and loop fasteners. See figure.
7. Loosen the battery terminals, see figure. below. Also see the sticker on the inside of the chassis front cover.
8. Lift/pull the battery out of the chassis.

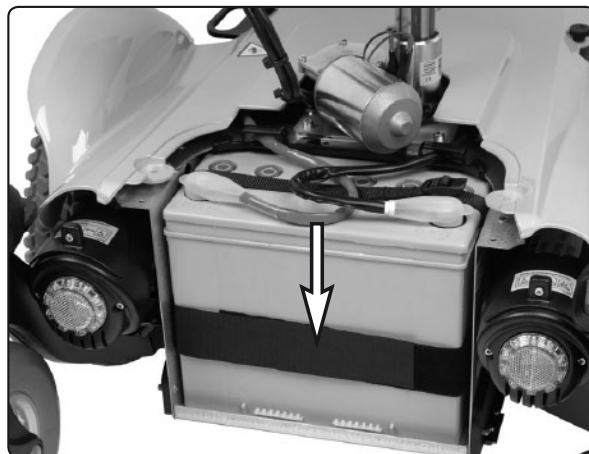

Loosen the battery holder strap.

⚠ WARNING!

Observe care in the use of metallic objects when working with batteries. A short-circuit can easily cause an explosion. Always use protective gloves and protective eye-glasses.

The batteries are heavy and must be handled with care.

Used or broken drive batteries should be taken care of in an environmentally correct manner in accordance with locally applicable recycling directions.

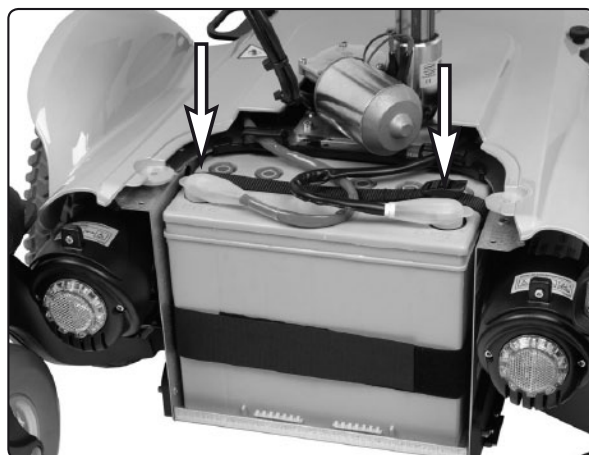

Battery terminals.

9. Lift/push the new battery in to the chassis. Remount the battery holder strap.
10. Connect the battery terminals on the new battery. Also see the sticker on the inside of the chassis front cover.
11. Remount the front cover.

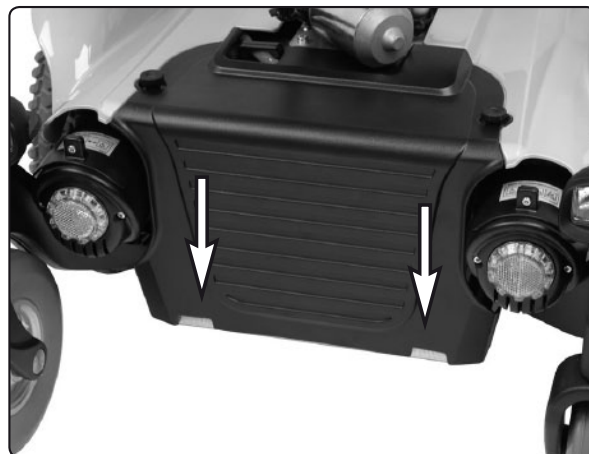

The front cover is fitted on the front edge of the chassis.

Changing the batteries

Rear battery

1. Place the wheelchair on a level surface.
2. Run/fold out the leg support and raise the seat lift.
3. Turn off the main power switch on the control panel.
4. Put the circuit breaker in the "OFF" position. It is accessed through a hole in the chassis cover; see fig.
5. Remove the front cover, see page 94.
6. Remove the chassis top cover, it's fitted with two knobs, see fig.

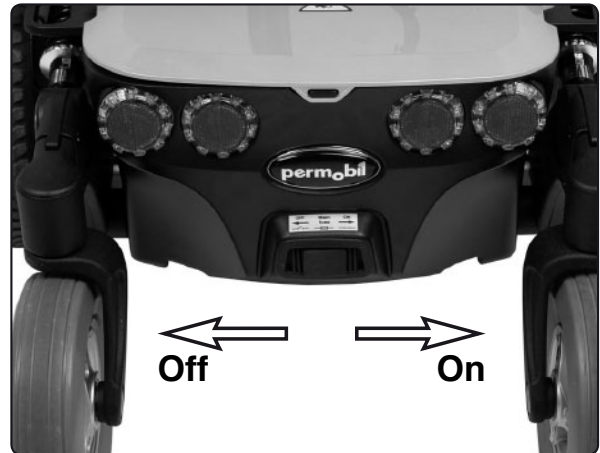

The circuit breaker is accessed through a hole in the chassis cover.

5. Remove the front cover, see page 94.
6. Remove the chassis top cover, it's fitted with two knobs, see fig.



Chassis top cover.

7. Pull the rear cover backwards and up.



Chassis rear cover.

Changing the batteries

Rear battery

8. Remove the electronics by pulling the release lips on the left and right hand side of the chassis outwards. See fig.
9. Loosen the battery holder strap, it's attached with hook and loop fasteners. See figure.
10. Loosen the battery terminals, see fig. Also see the sticker on the inside of the chassis rear cover.

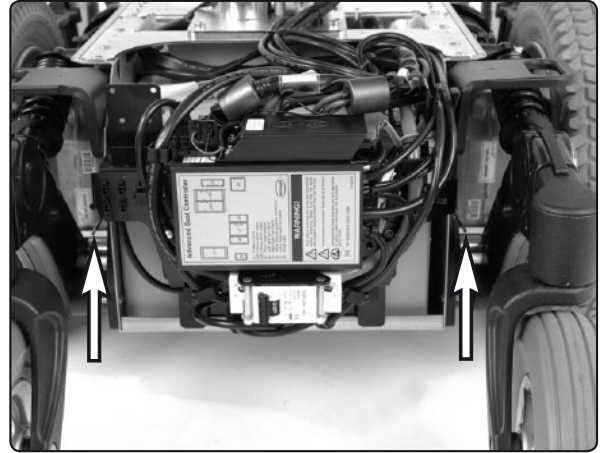

Pull the release lips to remove the electronics.

⚠ WARNING!

Observe care in the use of metallic objects when working with batteries. A short-circuit can easily cause an explosion. Always use protective gloves and protective eye-glasses.

The batteries are heavy and must be handled with care.

Used or broken drive batteries should be taken care of in an environmentally correct manner in accordance with locally applicable recycling directions.

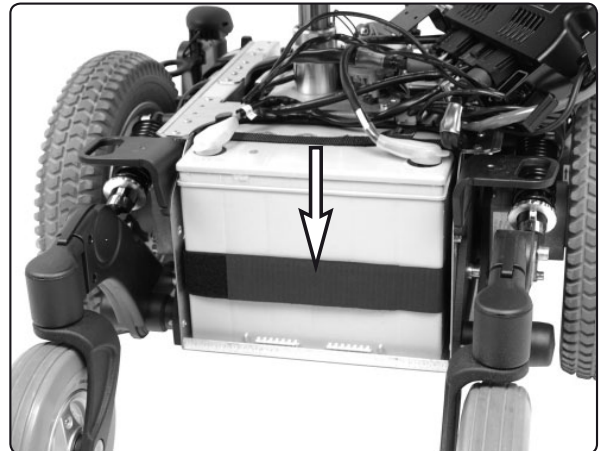

Battery lock.

11. Lift/pull the battery out using the battery strap.
12. Lift/push the new battery in to the chassis. Remount the battery holder strap.
13. Connect the battery terminals on the new battery. Also see the sticker on the chassis rear cover.
14. Remount the electronics. See fig above.
15. Remount the chassis covers.

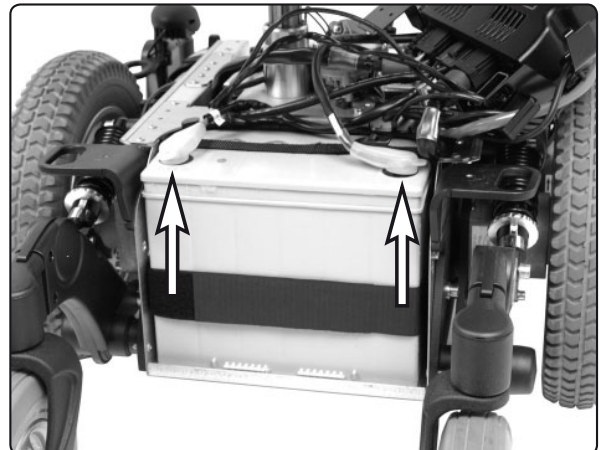

Battery terminals.

Resetting the Circuit Breaker

⚠ WARNING!

A triggered automatic Circuit Breaker can indicate larger electrical faults. The cause should be checked carefully before the Circuit Breaker is reset. Always contact an authorized Permobil Service Center or Permobil when in doubt.

The circuit breaker also serves as a battery isolator, but is normally referred to as a circuit breaker.

Replacement of the circuit breaker is normally not necessary as it is of the automatic type that can be reset when it has been triggered. The resetting is done by placing the switch in the "ON" position.

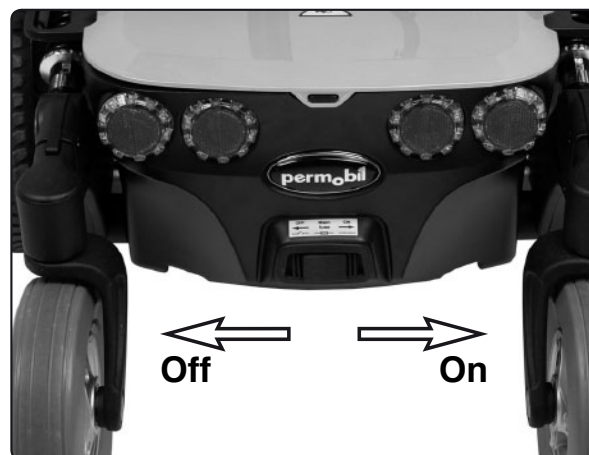

The circuit breaker is accessed through a hole in the chassis cover.

⚠ CAUTION!

Always shut off the Power Supply on the Control Panel before switching off the power with the Circuit Breaker.

Accessories

We are constantly developing accessories for our wheelchairs. Contact your nearest Permobil retailer for more information about the accessories available for your wheelchair.

Technical Specifications

The specifications given in the following pages are only applicable to the Permobil M400 chassis with Corpus 3G.

For size and weight information about each seat, see the Owner's Manual accompanying the seat.

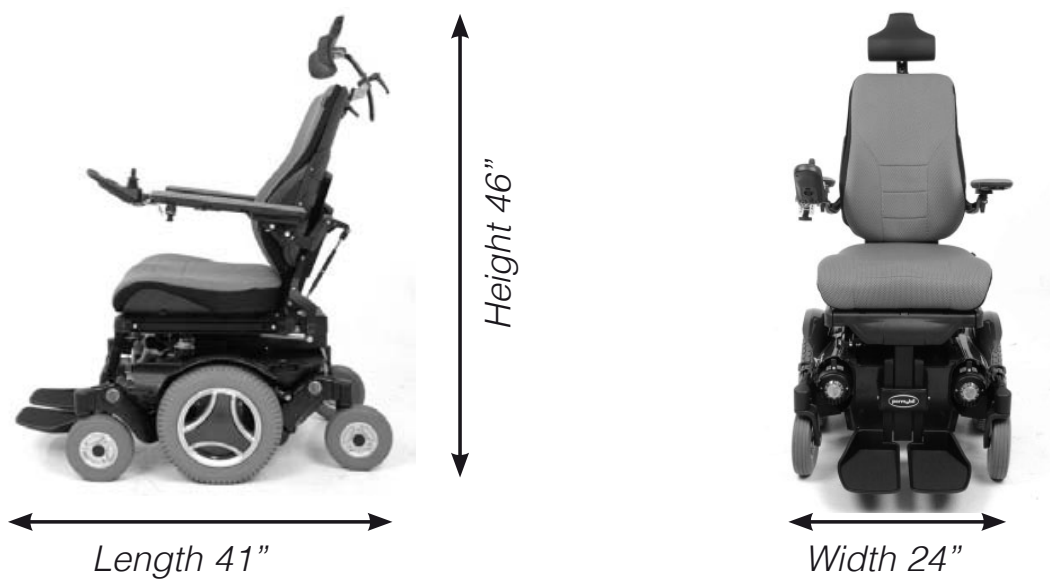

Smallest transportation size = length 31", width 24", height 32"

DATA

General

Name Permobil M400

Size and weight

Length 41"
 Width 24"
 Height 46"
 Smallest Transport Size, lwxh 31"x24"x32"
 Weight incl. Batteries and Corpus 3G Seat 405lbs
 Max. Battery Size 10.2x6.6x7"

Wheels

Tire Size, Drive wheels 3.00-8
 Tire Size, Turning wheels 200x50
 Recommended Air Pressure 29 psi (200kPa)

Performance

Range (Rnet)..... 19.6 Miles
 Minimum Turning Radius 26"
 Turn around width 42"
 Ability to Negotiate Obstacles 3"
 Min. ground clearance 3.1"
 Hill-climbing ability 9 degrees
 Safe slope 8 degrees
 Sideways Slope Capability..... 9 degrees
 Static stability downhill 16 degrees
 Static stability uphill..... 10.5 degrees
 Static stability sideways 14.5 degrees
 Max Speed Forward..... 7.5 mph.

| ELEKTRONIKSYSTEM VR2 | ELEKTRONIKSYSTEM R-Net |
|---|--|
| <p>Electronics PM90-A2</p> <p>Control Panel JSM/JSM-L</p> <p>Batteries Recommended Battery Type .Group 34, Gel Battery Capacity 2x72 Ah Charging Time..... approx. 8 hour.</p> <p>Fuses Main Fuse..... 63A</p> <p>Required Operating Force Joystick..... 1,5 Nm Buttons 2,0 Nm</p> | <p>Electronics PM120</p> <p>Control Panel JSM-L-SV</p> <p>Batteries Recommended Battery Type .Group 34, Gel Battery Capacity 2x72 Ah Charging Time..... approx. 8 hour.</p> <p>Fuses Main Fuse..... 63A</p> <p>Required Operating Force Joystick..... 1,5 Nm Buttons 2,0 Nm</p> |

VR2-Diagnostics

Battery charge indicator

Whenever an error on the wheelchair's control system occurs, information about this is shown on the control panel's battery charge indicator and the speed indicator by one or more blinking LED:s.

This information can be used for diagnosing the error.

The remedying of errors that are indicated via the blinking LED:s must be performed by a person with sufficient expertise to be able to perform such in a professional manner. Always contact an authorized serviceman when in doubt. More information about service and repairs is found in the chassis service manual.

Constant light

Everything is in order. How many lights are lit, depends upon how much voltage there is in the batteries. With fully charged batteries, all lights are lit.

Slowly blinking red lights, 1-2

The batteries need to be charged immediately.

Rapidly blinking, 1 - 10 lights

Error signals, an error has arisen and the wheelchair can not be driven.

- Note the number of blinking lights.
- Turn off the wheelchair.
- Turn the wheelchair back on again.
- If the error persists, count the number of blinking lights, check possible causes and solutions in the table on the adjoining page.

Don't use the wheelchair before you get it repaired, or get other instructions from your service provider.

WARNING!

The remedying of errors that are indicated via the control panel display must be performed by a qualified service technician authorized by Permobil to perform such service on Permobil products.

Permobil Inc. is not responsible for personal injuries or damage resulting from inappropriate or wrongly performed repairs.

CAUTION!

If the error is in a non-active module, then drive will still be possible, however, the diagnostic screen will appear intermittently.

ERROR CODE

POSSIBLE CAUSE - SOLUTION

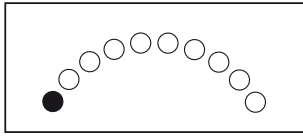

1 LED - Low battery voltage

Check the battery and the connections between the battery and the control unit.

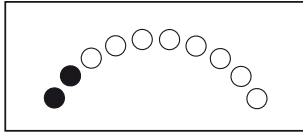

2 LED - Open circuit, left drive motor

Check the connection to the right drive motor.

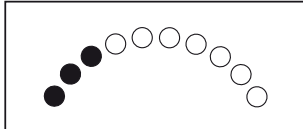

3 LED - Short circuit left drive motor

Check the drive motor connections and cable.

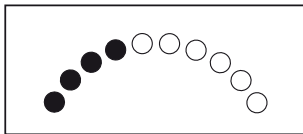

4 LED - Open circuit, right drive motor

Check the connection to the right drive motor.

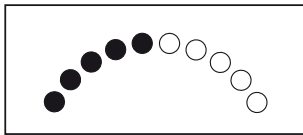

5 LED - Short circuit right drive motor

Check the drive motor connections and cable.

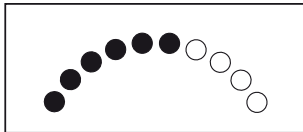

6 LED - Charger connected

Remove the charge plug from the chargesocket on the control panel.

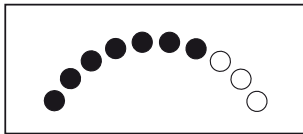

7 LED - Joystick error

Make sure the joystick isn't actuated at switch-on, change the control panel.

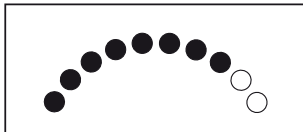

8 LED - Control System Error

Check the contacts to the power module. If the fault persists, change the power module.

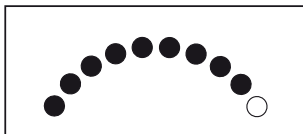

9 LED - Failure in wheel lock circuit

Check the connections to the magnetic wheel lock.

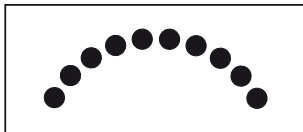

10 LED - High battery voltage

Check the battery and the connections between the battery and the control unit.

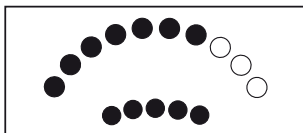

7+5 LED - Communication error

Check the control panel cable for damage and make sure the cable connections aren't loose.

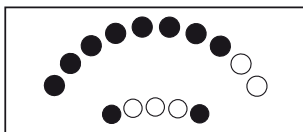

8+2 LED - Actuator error

If the wheelchair has more than one actuator, check which one isn't working. Make sure the cable connections aren't loose.

Diagnostics R-Net LCD

Whenever an error on the wheelchair's control system occurs, information about this is shown on the control panel's display. This information can be used for diagnosing the error.

The remedying of errors that are indicated via the control panel display must be performed by a person with sufficient expertise to be able to perform such tasks in a professional manner. Always contact an authorized Permobil Service Center when in doubt. More information about service and repairs is found in the chassis service manual.

Diagnostic Screens

Current Diagnostic Screen

When the control system safety circuits have operated and the control system has been prevented from moving the wheelchair, a diagnostics screen will be displayed.

This indicates a system trip, i.e. the R-net has detected a problem somewhere in the wheelchair's electrical system.

CAUTION!

If the error is in a non-active module, then drive will still be possible, however, the diagnostic screen will appear intermittently.

Switch off the control system for a couple of minutes. Switch on the control system again and try to drive the wheelchair. If the safety circuits operate again, do not try to use the wheelchair. Write down the information shown on the display and switch the control system off. Contact your service provider.

Don't use the wheelchair before you get it repaired, or get other instructions from your service provider.

WARNING!

The remedying of errors that are indicated via the control panel display must be performed by a qualified service technician authorized by Permobil to perform such service on Permobil products.

Permobil Inc. is not responsible for personal injuries or damage resulting from inappropriate or wrongly performed repairs.

Example of R-net Display showing an error

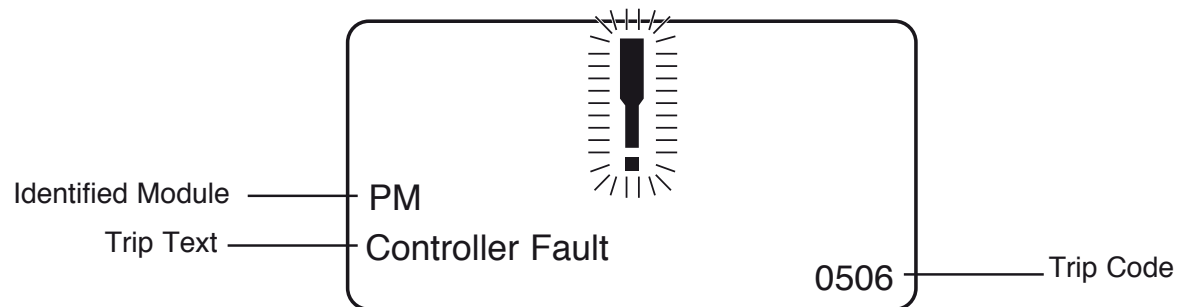

Identified Module

This identifies which module of the control system has registered the problem.

PM: Power Module

JSM: Joystick Module

Trip Text

The Trip Text gives a brief description of the trip type.

Trip Code

The 4 digit code displayed gives the exact trip that has been recorded.

Servicing of Defective Units

Excluding specific OEM approved replacement parts (for details of these contact Permobil), there are no serviceable parts in the R-net control system. Consequently, any defective units must be returned to Permobil or a Permobil authorized service center for repair..

CAUTION!

Any replacement work carried out without Permobil's permission will invalidate the control system's warranty. Permobil accepts no liability for losses of any kind arising from unauthorized opening, adjustments or modifications to any component of the R-net control system.

Diagnostics R-Net LED

Battery voltage indicator

Each time the wheelchair is started up, parts of the wheelchair's electronics are checked. If any fault has occurred in these parts, this is displayed on the control panel's battery voltage indicator and the indicator for speed/driving profile in the form of one or more flashing lamps.

Troubleshooting and repairs must always be performed by competent personnel with good knowledge of the wheelchair's electronics. More information on troubleshooting and remedies can be found in the Service Manual for this wheelchair model.

Permanently on

All in order. The number of lamps that light up depends on the voltage remaining in the batteries. If the batteries are fully charged, all the lamps light up.

Slowly flashing red lamps, 1 - 2

The batteries need recharging immediately.

Rapid flashes, 1 - 10 lamps

A fault has been detected in the wheelchair's electronics and the wheelchair cannot be driven.

- Switch off the wheelchair.
- Check that all visible cables and the cable to the control panel are connected correctly.

Switch the wheelchair on again. If the fault persists, count the number of flashing lamps and check for a possible cause and remedy in the table on the adjoining page.

Do not use the wheelchair until the problem has been remedied or you have received other instructions from your service contact.

WARNING!

Diagnostics should only be performed by persons with sound knowledge of the wheelchair's electronic control system. Incorrect or poorly performed repair work may make it dangerous to use the wheelchair. Permobil accepts no liability for any personal injury or damage to the wheelchair and its surroundings that may occur on account of incorrect or poorly performed repair work.

CAUTION!

Any error signals on the indicators are not displayed while the wheelchair is being driven. They appear when it is next started.

ERROR SIGNAL

ERROR INDICATION - REMEDY

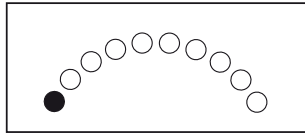

1 Lamp - Low battery voltage

Check the condition of the battery. Check the contact between the battery and the control unit.

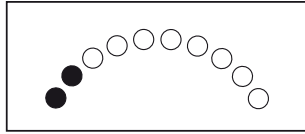

2 Lamps - Failure in left-hand drive motor

Check the connection to the left-hand drive motor.

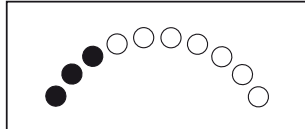

3 Lamps - Short-circuit in left-hand drive motor

Check the drive motor's contacts and cables.

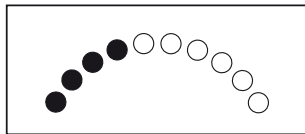

4 Lamps - Failure in right-hand drive motor

Check the connection to the right-hand drive motor.

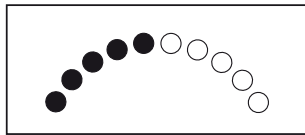

5 Lamps - Short-circuit in right-hand drive motor

Check the drive motor's contacts and cables.

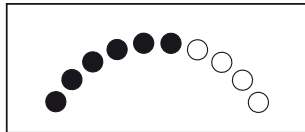

6 Lamps - Battery charger connected

Disconnect the battery charger.

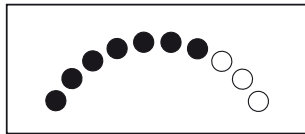

7 Lamps - Joystick error

Check that the joystick is not being moved when the wheelchair is started

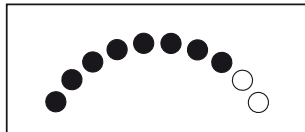

8 Lamps - Control system error

Check the contacts to the output stage.

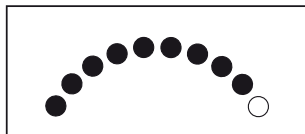

9 Lamps - Failure in brake circuit

Check the contacts to the magnetic brake.

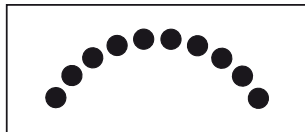

10 Lamps - High battery voltage

Check the battery and the contacts between the battery and the control unit.

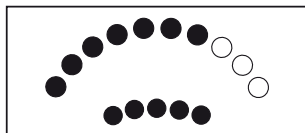

7+5 Lamps - Communication error

Check that the cable to the control panel is correctly inserted and is not damaged.



Actuator indicator - Actuator error

If the wheelchair is fitted with more than one actuator, check which one is not working. Check the actuators' cable connections.

Trouble Shooting Guide

The troubleshooting guide below describes a number of events that can arise when you use your wheelchair, as well as providing suggestions for solutions. Note that this guide does not describe all the possible events that can arise, and you should always get in touch with your service contact or Permobil when you are unsure

| EVENT | POSSIBLE CAUSE | SOLUTION |
|--|---|--|
| The wheelchair does not start. | Batteries discharged. | Charge the batteries. |
| | The cable connection to the control panel has become loose. | Attach the cable to the control panel. |
| | Circuit Breaker set in "OFF" position after, for example, changing batteries. | Reset the Circuit Breaker. See page 98. |
| | Triggered Circuit Breaker. | See page. 98. |
| The wheelchair can not be driven. | Battery charger connected. | Terminate the charging and remove the charging cable from the charging outlet. |
| | Wheel Locks activated. | Reset the Wheel Locks. |
| | The wheelchair is locked. | Unlock the wheelchair. See page 36.(VR2) alt. 68.(R-Net) |
| The wheelchair stops while being driven. | The cable connection to the control panel has become loose. | Attach the cable to the control panel. |
| | Triggered Circuit Breaker. | See page 98. |
| The wheelchair can only be driven with reduced speed. <i>Applies for electrical seat lift only.</i> | Seat lift raised from its lowest position. | Lower the seat lift. |
| The wheelchair will not charge. | Circuit Breaker set in "OFF" position after, for example, changing batteries. | Reset the Circuit Breaker. See page 98. |

⚠ WARNING!

It is very important that you read this information regarding the possible effects of Electromagnetic Interference on your powered wheelchair.

Electromagnetic Interference (EMI) From Radio Wave Sources

Powered wheelchairs and motorized scooters (in this text, both will be referred to as powered wheelchairs) may be susceptible to electromagnetic interference (EMI), which is interfering electromagnetic energy (EM) emitted from sources such as radio stations, TV stations, amateur radio (HAM) transmitters, two-way radios, and cellular phones.

The interference (from radio wave sources) can cause the powered wheelchair to release its parking brakes, move by itself, or move in unintended directions. It can also permanently damage the powered wheelchair's control system. The intensity of the interfering EM energy can be measured in volts per meter (V/m). Each powered wheelchair can resist EMI up to a certain intensity. This is called its "immunity level". The higher the immunity level, the greater the protection.

The immunity level of this powered wheelchair model as shipped, with no further modification, is 20V/m in the range of 26 MHz to 1000 MHz.

There are a number of sources of relatively intense electromagnetic fields in the everyday environment. Some of these sources are obvious and easy to avoid. Others are not apparent and exposure is unavoidable. However, we believe that by following the warnings listed below, your risk to EMI will be minimized.

The sources of radiated EMI can be broadly classified into three types:

1. **HAND-HELD PORTABLE TRANSCEIVERS** (transmitters-receivers) with the antenna mounted directly on the transmitting unit. Examples include: citizens band (CB) radios, "walkie talkie", security, fire, and police transceivers, cellular telephones, and other personal communication devices.

CAUTION! Some cellular telephones and similar devices transmit signals while they are ON, even when not being used.

2. **MEDIUM-RANGE MOBILE TRANSCEIVERS** such as those used in police cars, fire trucks, ambulances, and taxis. These usually have the antenna mounted on the outside of the vehicle.
3. **LONG-RANGE TRANSMITTERS AND TRANSCEIVERS** such as commercial broadcast transmitter (radio and TV broadcast antenna tower) and amateur (HAM) radios.

CAUTION! Other types of hand-held devices, such as cordless phones, laptop computers, AM/FM radios, TV sets, CD players, and cassette players, and small appliances, such as electric shavers and hair dryers, so far we know, are not likely to cause EMI problems to your powered wheelchair.

Because EM energy rapidly becomes more intense as one moves closer to the transmitting antenna (source), the EM fields from hand-held radio wave sources (transceivers) are of special concern. It is possible to unintentionally bring high levels of EM energy very close to the powered wheelchair's control system while using these devices. This can affect powered wheelchair movement and braking. Therefore, the warnings listed below are recommended to prevent possible interference with the control system of the powered wheelchair.

WARNINGS

Electromagnetic interference (EMI) from sources such as radio and TV stations, amateur radio (HAM) transmitters, two-way radios, and cellular phones can affect powered wheelchairs and motorized scooters. Following the warnings listed below should reduced the chance of unintended wheel lock release or powered wheelchair movement which could result in serious injury.

- Do not operate hand-held transceivers (transmitters/receivers), such as citizens band (CB) radios, or turn ON personal communications devices, such as cellular phones, while the powered wheelchair is turned ON.
- Be aware of nearby transmitters, such as radio or TV stations, and try to avoid coming close to them.
- If unintended movement or wheel lock release occurs, turn the powered wheelchair OFF as soon as it is safe.
- Be aware that adding accessories or components, or modifying the powered wheelchair, may make it more susceptible to EMI.

CAUTION! There is no easy way to evaluate their effect on the overall immunity of the powered wheelchair).

- Report all incidents of unintended movement or wheel lock release to the powered wheelchair manufacturer, and note whether there is a radio wave source near by.

US

Permobil M400



Article no.: 205258-US-0