

drive

DeVilbiss
HEALTHCARE



Seren Powerchair

User Manual

CE

TABLE OF CONTENTS

INTRODUCTION	1
IMPORTANT PRECAUTIONS	2
ELECTROMAGNETIC INTERFERENCE AND WARNINGS	3
IDENTIFICATION OF PARTS	5
OPERATING YOUR POWER CHAIR	8
DISASSEMBLING / RE-ASSEMBLING YOUR POWER CHAIR	12
CHARGING THE BATTERIES	14
CARE AND MAINTENANCE	16
TROUBLESHOOTING	18
TECHNICAL SPECIFICATIONS	20

INTRODUCTION

Thank you and congratulation on purchasing your new Power Chair. It is designed to provide you with transportation ability indoors and outdoors.

We pride ourselves on providing safe and comfortable products. Our goal is to ensure your complete satisfaction with our product. We are certain that you will enjoy your Drive DeVilbiss power chair.

Please read and observe all warning and instruction provided in owner's manual before operating with this power chair. Also, retain this booklet for future reference.

If you have any question, please contact your local dealer or:

Information of European Representative :

EMERGO EUROPE

Molenstraat 15
2513 BH, The Hague
The Netherlands

IMPORTANT PRECAUTIONS

- Only one person at a time can ride a Drive DeVilbiss Power Chair.
- Maximum load is 136 kg/300 lbs.
- Turn off power before getting on or off your power chair.
- Always drive carefully with your feet on the footplate and be aware of others in your area.
- Always use pedestrian crossings wherever possible. Take extreme when care crossing roads.
- Do not drive on slopes exceeding 6 degrees, and take extreme care when turning on slopes.
- Do not use full power when turning to sharp corners.
- Take great care and drive in low speeds when backing up, riding downhill, or on uneven surfaces and climbing curb.
- The power chair may not operate well in high humidity.
- Never put your power chair in neutral when staying on slopes.
- Follow all traffic laws when riding in the vicinity of public roads.
- It is NOT recommended to use your power chair in wet environments as it may cause damage.

ELECTROMAGNETIC INTERFERENCE AND WARNINGS

CAUTION: It is very important that you read this information regarding the possible effects of Electromagnetic Interference on your power chair.

Powered wheelchairs and motorized scooters may be susceptible to electromagnetic interference (EMI), which is interfering electromagnetic energy (EM) emitted from sources such as radio stations, TV stations, amateur radio (HAM) transmitters, two-way radios, and cellular phones. The interference (from radio wave sources) can cause the motorized scooter to release its brakes, move by itself, or move in unintended directions. It can also permanently damage the motorized scooter control system. The intensity of the interfering EM energy can be measured in volts per meter (V/m). Each motorized scooter can resist EMI up to a certain intensity. This is called its "immunity level." The higher the immunity level, the greater the protection will be. At this time, current technology is capable of achieving at least a 20 V/m immunity level, which would provide useful protection from the more common sources of radiated EMI. The immunity level of this motorized scooter model is 20 V/m.

There are a number of sources of relatively intense electromagnetic fields in the everyday environment. Some of these sources are obvious and easy to avoid. Others are not apparent and exposure is unavoidable. However, we believe that by following the warnings listed below, your risk to EMI will be minimized.

The sources of radiated EMI can be broadly classified into three types :

1. Hand-held portable transceivers (transmitters-receivers) with the antenna mounted directly on the transmitting unit. Examples include: citizens band (CB) radios, "walkie talkie," security, fire, and police transceivers, cellular telephones, and other personal communication devices.



Some cellular telephones and similar devices transmit signals while they are ON, even when not being used.

2. Medium-range mobile transceivers, such as those used in police cars, fire trucks, ambulances, and taxis. These usually have the antenna mounted on the outside of the vehicle.

3. Long-range transmitters and transceivers such as commercial broadcast transmitters (radio and TV broadcast antenna towers) and amateur (HAM) radios.



Other types of hand-held devices, such as cordless phones, laptop computers, AM/FM radios, TV sets, CD players, and cassette players, and small appliances, such as electric shavers and hair dryers, so far as we know, are not likely to cause EMI problems to your motorized scooter.

Power Chair Electromagnetic Interference :

Because EM energy rapidly becomes more intense as one moves closer to the transmitting antenna (source), the EM fields from hand-held radio wave sources (transceivers) are of special concern. It is possible to unintentionally bring high levels of EM energy very close to the power chair control system while using these devices. This can affect power chair movement and braking. Therefore, the warnings listed below are recommended to prevent possible interference with the control system of the power chair.

Warnings :

Electromagnetic interference (EMI) from sources such as radio and TV stations, amateur radio (HAM) transmitters, two-way radios, and cellular phones can affect the power chair. Following the warnings listed below should reduce the chance of unintended brake release or power chair movement, which could result in serious injury.

1. Do not operate hand-held transceivers (transmitters-receivers), such as citizens band (CB) radios, or turn ON personal communication devices, such as cellular phones, while the power chair is turned ON;
2. Be aware of nearby transmitters, such as radio or TV stations, and try to avoid coming close to them;
3. If unintended movement or brake release occurs, turn the power chair OFF as soon as it is safe;
4. Be aware that adding accessories or components, or modifying the power chair, may make it more susceptible to EMI; and
5. Report all incidents of unintended movement or brake release to the distributor listed on the inside front cover of this manual. Note whether there is a source of EMI nearby.

Important Information

1. 20 volts per meter (V/m) is a generally achievable and useful immunity level against EMI (as of May 1994). The higher the level, the greater the protection.
2. The immunity level of this product is 20 V/m.

IDENTIFICATION OF PARTS

Before attempting to drive this power chair on your own, it is important that you familiarize yourself with the controls and how they operate.

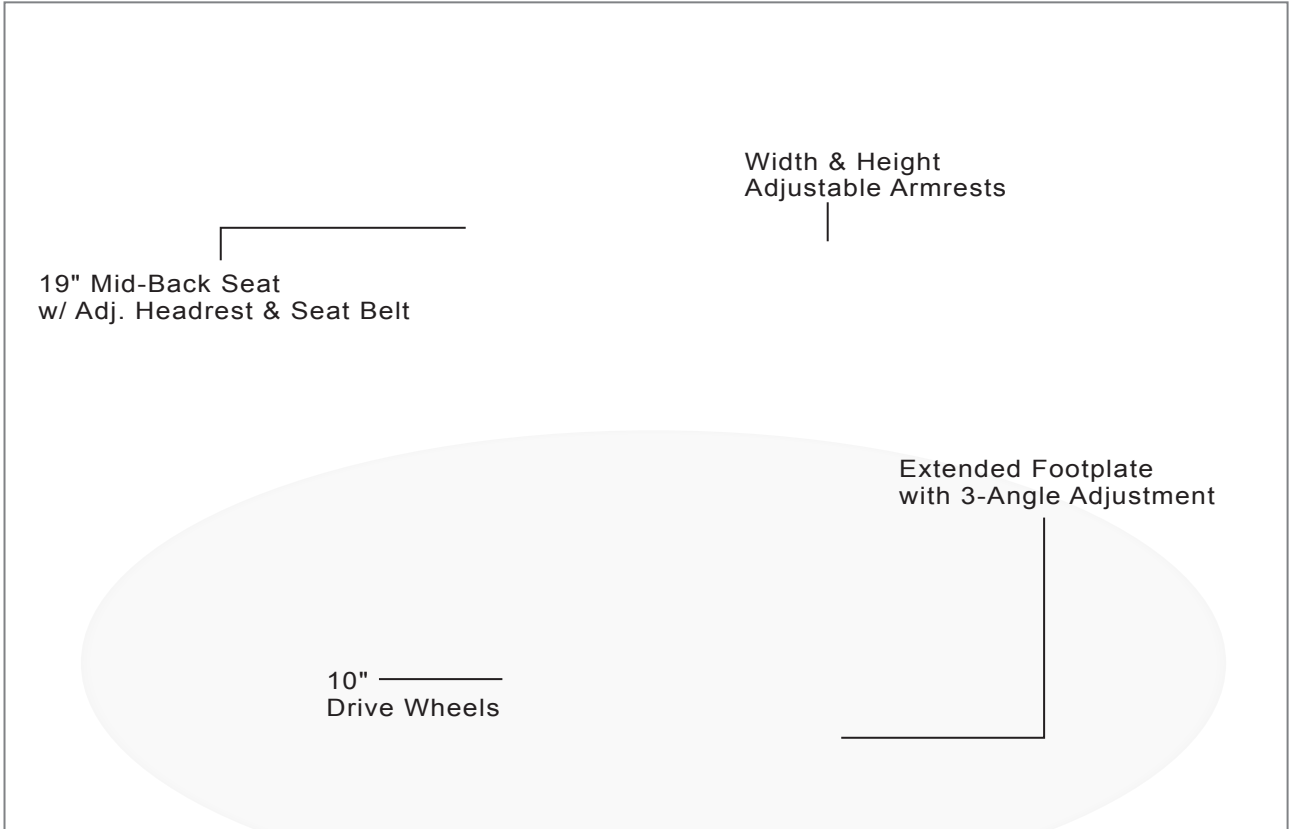

Figure 1 - Seren Power Chair Front View

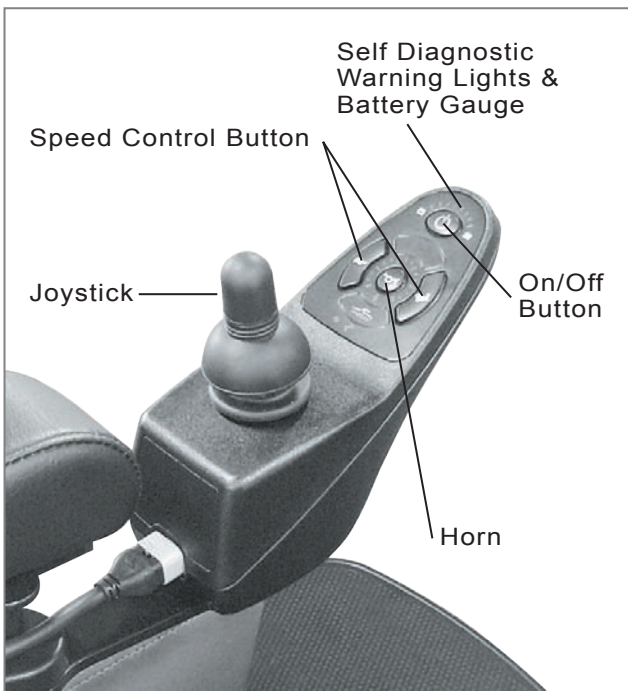

Figure 2 - Seren Joystick



Figure 3 - Seren Power Chair Rear View

JOYSTICK :

- Self Diagnostic Warning Lights

Flashing of lights indicates there is a problem within power chair. See page 18 for more information.

- Battery Gauge

There are eleven LED lights on joystick. When all LED lights are on, batteries are fully charged; The Battery Gauge is used to indicate power on and provides an estimate of the remaining battery capacity.

Any green LEDs lit indicate well charged batteries.

If only amber and red LEDs are lit, the batteries are moderately charged. Recharge before undertaking a long trip.

If only red LEDs are lit, the batteries are running out of charge. Recharge as soon as possible.

- Extendable Bracket

By releasing Knob (B) the joystick bracket (C) is able to extend and retract. With joystick retracted, this enables you to pull up to any table, and tighten knob (B), when adjusted to a comfortable position.

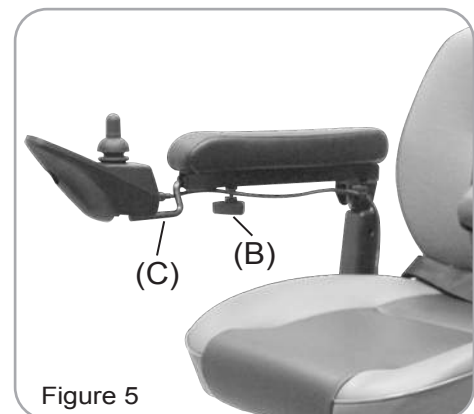
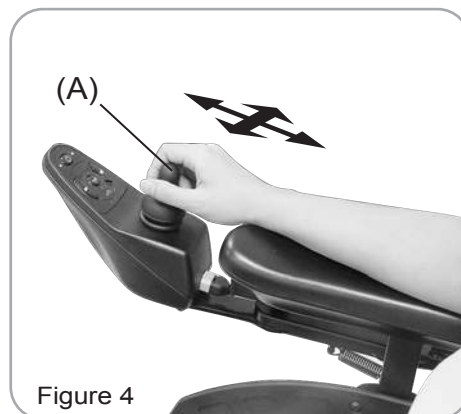
**ARMREST :**

- Armrest width & height Adjustment Thumbscrews

Loosen two thumbscrews to adjust armrest width & height tighten again to lock in desired position.

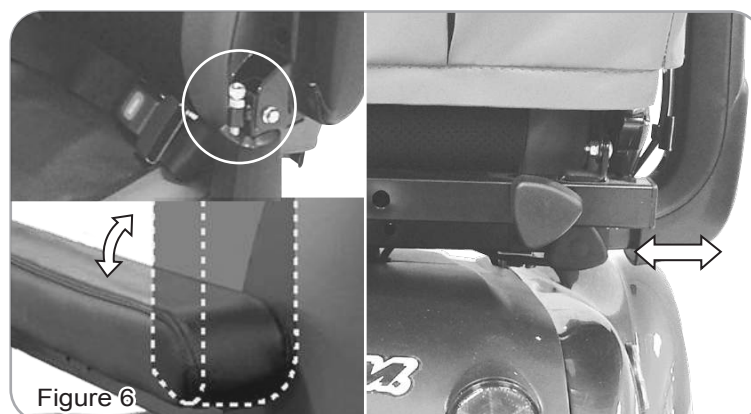

FOOTPLATE :

• Footplate

The footplate can be adjusted according to your specific needs. It can be width & adjusted vertically or horizontally. To adjust footplate, loosen screw and arrange height to desired position, then, tightened screw to secure plate in place. (D & E)

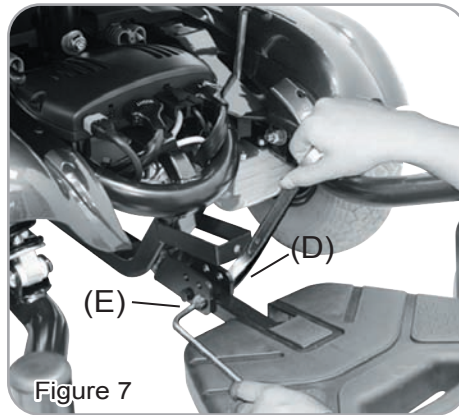
**POWER BASE :**

• Free-Wheeling Lever

When lever is in N (Neutral) position, power chair can be moved manually.

When lever is in D (Drive) position, power chair can be driven. Normal position is D.



OPERATING YOUR SCOOTER

Before beginning your journey with your new power chair, make sure power chair is on a level surface and clear of any obstacle. Although your power chair is able to climb slopes, it is safer to practice on a leveled surface.

1. Before operating with your power chair, check the following:
 - free-wheeling lever is on D.
 - speed dial is at the lowest speed (fully turned counterclockwise).
2. Sit on chair and fasten seat belt.

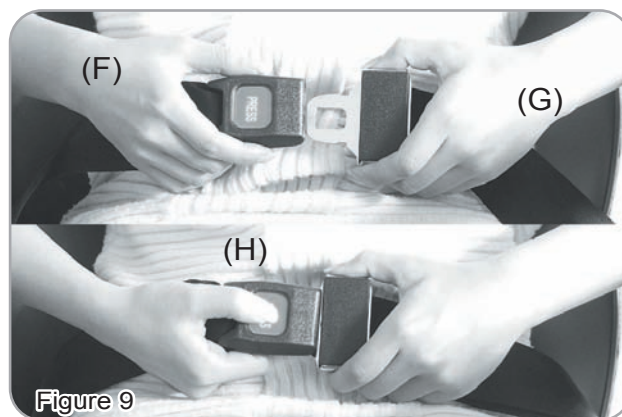

3. When power is turned on, all battery gauge LED lights should be lit lighting. The self-diagnostic warning lights should not be blinking.
4. While resting your arm on armrests, joystick should be within reach. By pushing joystick slightly forward, power chair will move forward slowly, and pushing joystick fully forward, chair will move at normal speed. And adjusting speed dial will also decrease or increase speed. Also, with joystick, you are able to turn chair in 360°. When joystick is let go and back in center position, chair will stop.

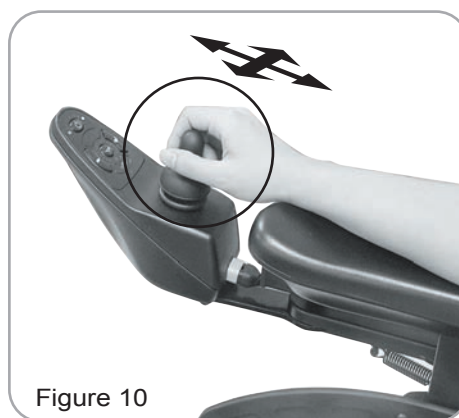

5. Practice driving where there is no obstacle. Start at slowest speed and move forward and backward; make some turns. As you get more comfortable, you can increase the speed by turning speed dial knob clockwise.

Headrest Adjustment :

By pressing (k) to adjust the headrest (J) up & down to a comfortable position.

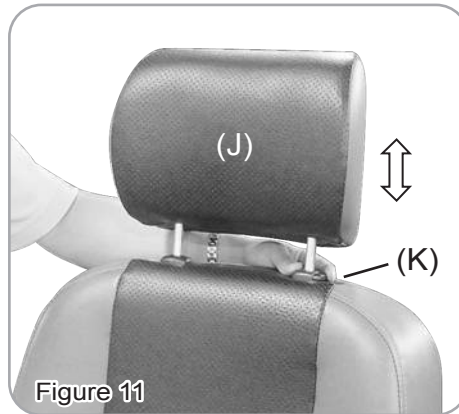

Figure 11

Seat Adjustment :

By lifting up lever (L) to rotate seat (See Fig. 12)

Note: Do not swivel seat angle over 90 degrees, to prevent wires twist.



Figure 12



While standing up, avoid stepping on footplate as it may cause injury.

The batteries should be charged as soon as possible after each ride. See **CHARGING THE BATTERIES** on page 14.

Optional Seat (A~D) :

(A). Armrests' Width Adjustment

By releasing both sides knobs, and adjust armrests to a comfortable position, then tighten with knobs.

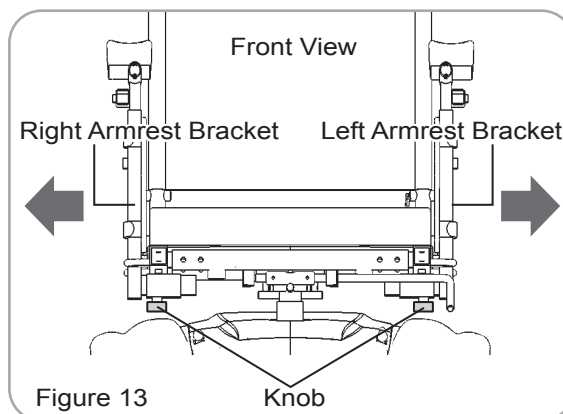
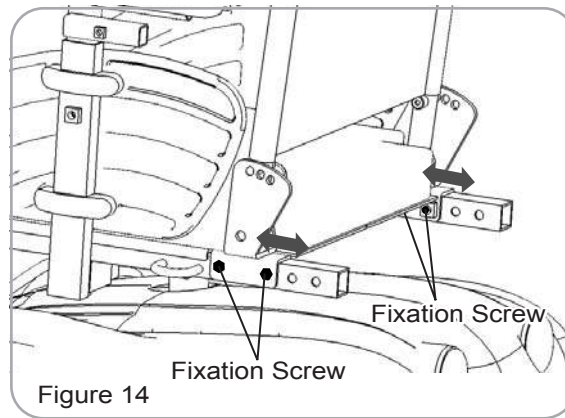

Figure 13

(B). Seat's Depth Adjustment

By releasing fixation screws from back sides, and adjust to a comfortable position, then tighten with fixation screws.



(C). Backrest Angle Adjustment

By pulling the fixation vel-cro backwards to disengage the pins from the holes, and adjust angle to a comfortable position, then release fixation vel-cro to engage to it's position.

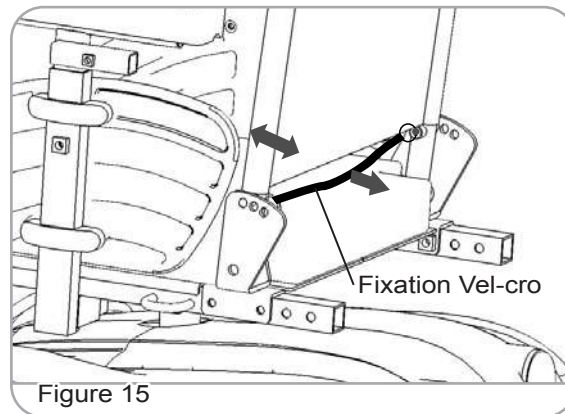

(D). Seat's Width Adjustment

1. By taking front&rear and support brace's fixation screws(9pcs) off.
2. Take off backrest pad by release it's vel-cro.

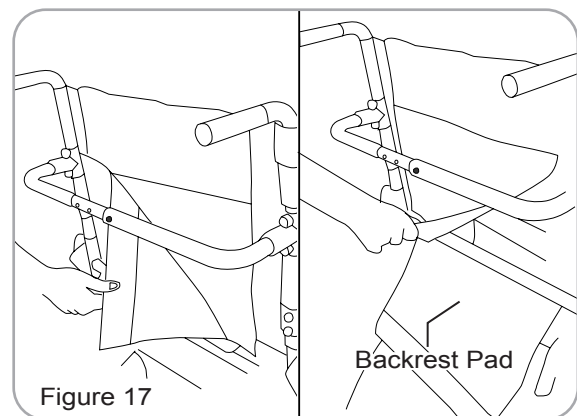
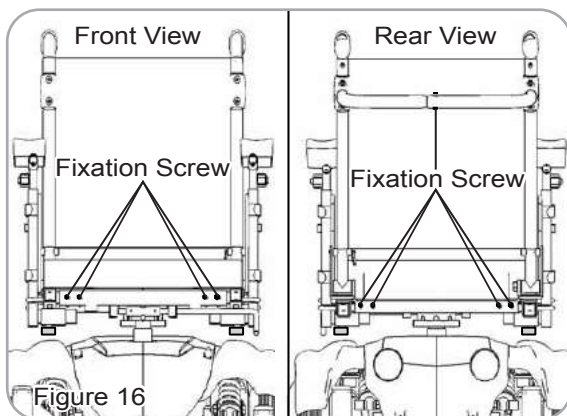

3. Release all backrest's vel-cro straps.
4. Adjust frame to a comfortable width position and adjust vel-cro to appropriate tightness, then put backrest pad back, complete by tighten 9pcs of width fixation screws.

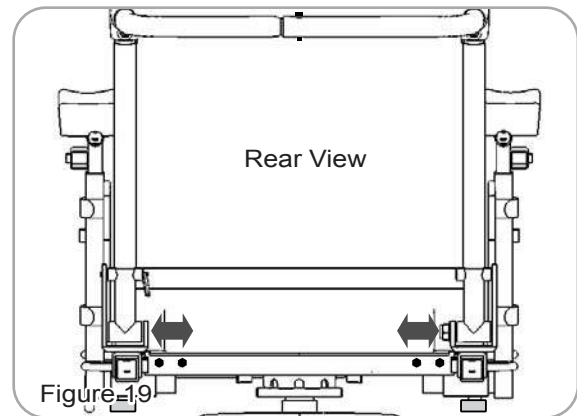
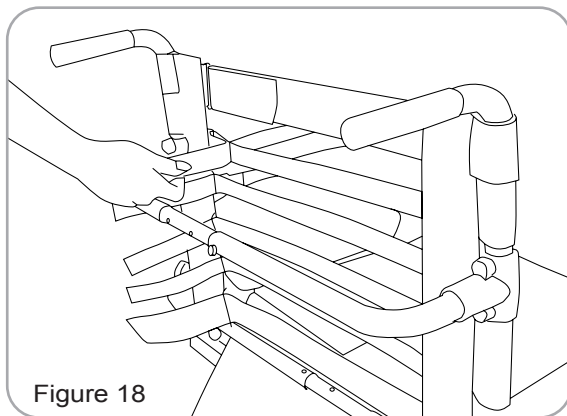

Keep in mind these rules :

- Use your power chair only where it is safe for walking.
- Drive in low speed when reversing, riding downhill on ramp or curb or on uneven surface.

Other Operating Information :

Hill climbing : You may need to use a higher speed. For a higher speed, turn speed dial clockwise.

Down slopes : Proceed with downward slope slowly, and turn speed dial counterclockwise. This enables good control when speed is set in slower motion. However, your power chair will not self accelerate down hills due to automatic braking, taking effect should you attempt to drive too fast.

Curb climbing : Approach slowly from right angles to the curb. A direct approach is needed. Do not attempt greater than a 2" curb.

If Self-Diagnostic Warning Lights start to flash, identify problem from chart on page 18 and take action.

If power chair breaks down and must be moved, please follow below directions :

1. Get off power chair.
2. Push free-wheeling lever to N.
3. Move power chair slowly to a safe location.
4. Push free-wheeling lever back to D.

DISASSEMBLING / RE-ASSEMBLING YOUR POWER CHAIR

Taking apart your power chair enables you to save space when keeping it in storage or carrying it along in your vehicle. Having power chair disassembled is easier than ever since no tools are required.

Joystick Cable Removal :

Please follow instructions below to remove joystick cable (M) from armrest.

1. Unplug joystick cable (See Fig. 20).
2. Press lock pins underneath front and along seat sides to unlock, then lift chair up to remove (See Fig. 21) Joystick cable is tied up by 3 cord clips on armrest (See white circle). Remove cable from armrest.

Seat Removal :

1. Fold down seat back.
2. Pull up the seat lock lever (N).
3. Lift up on seat assembly (O) to ensure the seat is secure (See Fig. 14).

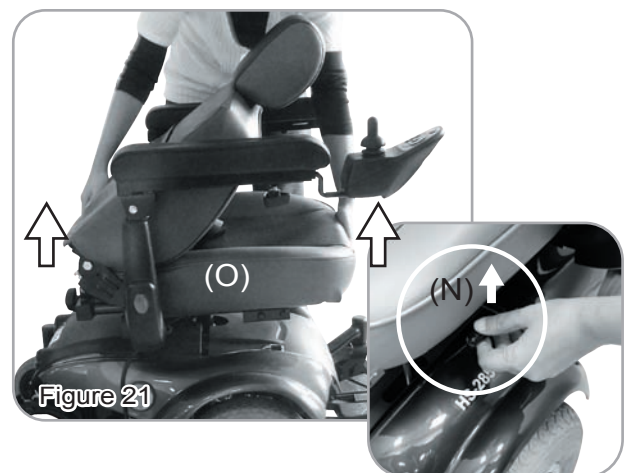

Body Shroud Removal :

1. Remove 3 push rivets (P1) from both front shroud (P) and rear shroud (P2).
2. Follow the arrow's direction to lift up shrouds (See Fig. 22).

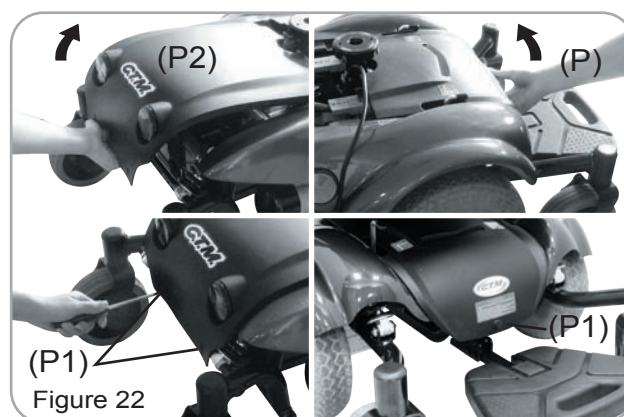

By using a screw driver to pressing down at the center of the push rivet, to release the shroud.

Battery Removal :

1. Disconnect two battery plugs (Q) (See Fig. 23).
2. Unfasten velcro strap that hold batteries in place (See Fig. 24).
3. Remove two batteries (S) (See Fig. 25).

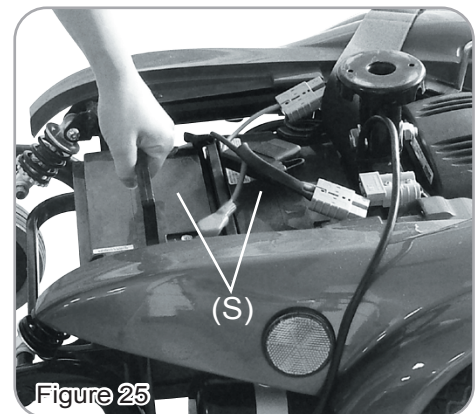
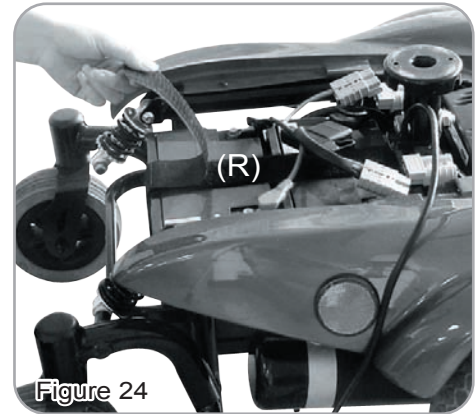

Be careful when carry the batteries as they are heavy.

DO NOT connect the Positive (+) to the Negative (-) battery terminal by any conductive metals.

Re-assemble :

To re-assemble your power chair, you can repeat disassembly directions in reverse.

CHARGING THE BATTERIES

Your Drive DeVilbiss power chair is equipped with two, service free 12V 36Ah rechargeable batteries and one 24V/5A off-board charger. Batteries must be charged before using power chair for the first time and it is recommended to be charged up to 8 - 14 hours after each day's use. Be sure power switch is in OFF position and free-wheeling lever is in "D" position.

Charging the batteries :

1. Position Seren power chair next to a standard wall outlet.
2. Insert the the battery charger cord into the chair input battery charging socket, which is located on the front of the joystick.
3. Plug the other end of power cord into a standard electrical wall outlet.
4. Switch the charger power On.



During the recharge :

While the batteries are being recharged, a orange light appear on the battery charger, indicating that the power is connected and charging is in progress.

At the end of the recharge cycle :

1. A green light will appear on the charger. This indicates that the batteries are fully charged and ready for use.
2. Please unplug power cord from wall outlet and power chair. The power cord should be stored in a safe and dry area until next use.



If charging your power chair for over 8 - 14 hours and it does not function, please check :

- fuse is not burned out
- power chair is turned off
- circuit breaker is pushed in
- if none of above is the problem, contact your authorized dealer.



The time needed to recharge will vary depending on depletion of batteries. Charging for longer than necessary will not harm batteries. They cannot be overcharged.

Keep in mind these rules :

- Fully charge batteries at least once a month; more if you use power chair regularly. Charge after each trip exceeding 3 kilometers / 1.86 miles.
- If storing your power chair for some time (one month or more) make sure batteries are fully charged, and on returning, charge them again before using power chair.

Batteries will only give maximum performance after power chair has been used, and batteries have been recharged up to 10 times.

For safety, please follow guidelines below.

1. DO NOT use charger if power cord is damaged.
2. DO NOT use an extension cord when charging batteries. A risk of fire and/or electric shock could be encountered.
3. DO NOT take charger apart, as this will void warranty.

CARE AND MAINTENANCE

Taking care of your power chair will keep it in top-notch condition. It is recommended that you have your dealer to provide a thorough inspection and servicing. Regular cleaning will reveal loose or worn parts and enhance the smooth operation of your powered scooter. Routine maintenance will extend the life and efficiency of your power scooter.

BODY SHROUD:

If your power chair is dirty, use a damp or lightly soapy cloth to wipe it down. Do not use running water to wash or rinse power chair in order to protect electrical parts. Polish with an automotive liquid polish.

SEAT AND ARMRESTS:

The seat material used by Drive DeVilbiss is of high quality and will remain in good condition for many years if treated responsibly. Using a damp cloth helps clean the upholstery greatly. Please note that using power chair outdoors could lead to sun damage to upholstery material, and normal wearing and tearing is not covered under warranty.

SEAT BELT:

A damp cloth with mild soapsuds should only be used to clean seat belts. Wipe seat belts gently and remove residue. Do not use any chemical products to clean seat belts as fabric will be weakened.



An authorized dealer should handle all maintenance and repair associating with electronics, batteries, motor parts, and tires. Here are the guidelines that can be followed by authorized dealer.

FLAT SPOT (for solid tires only):

During storage period, a flat spot may occur to solid tires. Weather conditions and storage period determine the condition of flat spots. By driving power chair 20 to 30 minutes, flat spots could be eliminated.

TIRE PRESSURE (for air-filled tires only):

The condition of tires and maintenance of specified tire pressures not only influence tire life, but also effect road safety to a very considerable extent. Incorrect pressure is often a cause of tire problems and could result in an accident. The recommended tire pressure is 35 psi.

TIRE TREAD:

Inspect the tires frequently for any signs of damage, such as unusual wearing or insufficient tread depth. Tread depth should not be allowed to drop below 1 mm.

ELECTRICAL CONNECTIONS:.

Make sure battery terminals and all plug connectors are secured and firmly attached. If battery terminals are corroded, please contact your dealer for replacement.

HARDWARE:

Check that all hardwares and are securely fastened. Replace any missing hardware by contacting your dealer.

STORING:

Also between uses, your power chair is best stored in a dry location at room temperature.

TROUBLESHOOTING

Flash codes indicate the nature of an abnormal condition directly from the SHARK Information Gauge. Without the use of any servicing tools, the condition can be simply diagnosed.

Flash Code	Description	
1	User Fault	Possible stall timeout or user error. Release the joystick to neutral and try again.
2	Battery Fault	Try charging the batteries. Batteries may require replacing. Check the batteries and cabling.
3	Left Motor Fault	Check the left motor, connections and cabling.
4	Right Motor Fault	Check the right motor, connections and cabling.
5	Left Park Brake Fault	Check the left park brake, connections and cabling.
6	Right Park Brake Fault	Check the right park brake, connections and cabling.
7	SHARK Remote Fault	Check the SHARK Communications Bus connections and wiring. Replace the Remote.
8	SHARK Power Module Fault	Check SHARK connections and wiring. Replace the Power Module.
9	SHARK Communications Fault	Check Battery voltage is greater than 17V. Check SHARK Bus Cable. Replace the SHARK Power Module. Replace the SHARK Remote.
10	Unknown Fault	Check all connections and wiring. Consult a service agent.
11	Incompatible Remote	The Remote is incompatible with the Power Module. Ensure the brand of the Power Module matches that of the Remote.

Other Problems :**• Power chair will not move when power is turned on :**

1. Check Battery Gauge on joystick. All LED lights should be on.
 2. Check Self-Diagnostic Warning Light. It should be steady; if it is flashing, see the chart on page 18 for problem identification.
 3. Check all electrical connections to be sure they are tight.
 4. Make sure batteries are connected correctly.
 5. If none of above correct problem, contact your authorized dealer.
-
- If charging your scooter for over 14 hours and light on charger does not change to green, then contact your authorized dealer.

SPECIFICATION

Seat Type	Mid-back Seat w/ Adj. Headrest & Seat Belt	Padded, Breathable Ballistic Nylon Back Rest
Overall Length	995 mm / 39"	995 mm / 39"
Overall Width	610 mm / 24"	610 mm / 24"
Overall Height	1080 mm / 42.5"	930 mm / 37"
Wheels: Front	155 mm / 6"	155mm / 6"
Wheels: Middle	260 mm / 10"	260 mm / 10"
Wheels: Rear	155 mm / 6"	155mm / 6"
Weight w/ Batteries	82 kg / 180.8 lbs	80 kg / 176 lbs
Max. Speed	6.7 kmph / 4.2 mph	6.7 kmph / 4.2 mph
Weight Capacity	136 kg / 300 lbs	136 kg / 300 lbs
Ground Clearance	60 mm / 2.4"	60mm / 2.4"
Grade Climbable	6 degree	6 degree
Curb Climbing	40 mm / 1.6"	40mm / 1.6"
Turning Radius	620 mm / 24.4"	620mm / 24.4"
Brake	Electro-Mechanical	Electro-Mechanical
Seat Width	490 mm / 19"	420-470 mm / 16.5"-18.5"
Seat Depth		450-475-500 mm / 17.7"-18.7"-19.6"
Armrest Height		225-250-270 mm / 8.9"-9.8"-10.6"
Seat Back Angle		100 - 120 degree
Seat Back Height		445 mm / 17.5"
Drive Train	2-Motor Mid-Wheel Drive	2-Motor Mid-Wheel Drive
Battery Weight	24.2 kg / 53 lbs	24.2 kg / 53 lbs
Motor Size	420W 4900 r.p.m	420W 4900 r.p.m
Travel Range	20 km / 12.4 Miles	20 km/ 12.4 Miles
Battery	(2) 12V. 36Ah	(2) 12V. 36Ah
Charger	5A Off Board	5A Off Board
Electronics	SHARK	SHARK

*Subject to change without notice.

Warranty Information

Drive DeVilbiss Seren Powerchairs are warranted for 12 months (24 months frame) from the date of purchase on side frames and crossbars. (NB Batteries are warranted for 12 months.)

- » During the warranty period any parts that have become defective due to faulty workmanship or material will be repaired or replaced without charge by Drive DeVilbiss supplier/dealer
- » The warranty excludes tyres, punctures and items that become worn due to normal wear and tear such as upholstery and armrest pads
- » The warranty excludes all items that have been subject to undue wear and tear and misuse
- » Unauthorised changes or modifications will forfeit your warranty
- » If a defect or fault is discovered, the Drive DeVilbiss supplier/dealer from whom the Wheelchair was purchased should be notified immediately

Limitation of Liability

The warranty does not extend to the consequential costs resulting from fault clearance, in particular freight and travel costs, loss of earnings, expenses, etc. The manufacturer will not accept responsibility for any damage or injury caused by misuse or non-observance of the instructions set out in this user manual.

Dealer Stamp



Drive DeVilbiss Healthcare Ltd, Heathfield Lane,
Birkenshaw, West Yorkshire, BD11 2HW

Tel: 0845 0600 333

Fax: 0845 0600 334

Email: info@drivedevilbiss.co.uk

www.drivedevilbiss.co.uk