



# **Safety & Operation Manual**

---

## **Spraytek® DS300 Sprayer**

84042 – Perkins Liquid Cooled Diesel Engine



*WARNING: If incorrectly used this machine can cause severe injury. Those who use and maintain this machine should be trained in its proper use, warned of its dangers and should read the entire manual before attempting to set up, operate, adjust or service the machine.*

# CONTENTS

---

<b>1</b> .....	<b>CONTENTS</b>	<b>6</b> .....	<b>OPERATION</b>
<b>2</b> .....	<b>SAFETY</b>	6.1	Daily Inspection ..... 14
2.1	Operating Safety ..... 3	6.2	Interlock System ..... 14
2.2	Important Safety Notes ..... 4	6.3	Operating Procedures ..... 15
2.3	Chemical Handling, Use and Storage ..... 4	6.4	Starting ..... 16
2.4	Recommended Safety Equipment ..... 5	6.5	Parking ..... 16
2.5	Work Area Safety Recommendations ..... 5	6.6	To Drive Vehicle ..... 17
<b>3</b> .....	<b>VEHICLE IDENTIFICATION NUMBERS</b>	6.7	Hillside Operation ..... 17
3.1	Vehicle Identification Number ..... 6	6.8	Towing the Vehicle ..... 18
3.2	Engine Identification Numbers ..... 6	6.9	Engine Overheat Procedure ..... 18
3.3	SDI Sprayer Tank Identification Numbers ..... 6	6.10	Daily maintenance ..... 19
<b>4</b> .....	<b>DECALS</b>	<b>7</b> .....	<b>SPRAYER OPERATION</b>
4.1	Decals ..... 7	7.1	Spray System Components ..... 20
<b>5</b> .....	<b>CONTROLS</b>	7.2	Control Valves ..... 21
5.1	Icons ..... 8	7.3	System Dynamics ..... 21
5.2	Control Descriptions ..... 10	7.4	Sprayer System Check ..... 22
5.3	Sprayer Control Systems ..... 12	7.5	Sprayer Tank additives ..... 24
		7.6	cALIBRATION ..... 25
		7.7	Measuring Ground Speed ..... 26
		7.8	Nozzle Tip Size ..... 26
		7.9	Determining Amount of Chemicals Required .... 28
		7.10	Adding water to tank. .... 29
		7.11	Mixing Chemicals ..... 30
		7.12	Sprayer Cleaning ..... 31
		<b>8</b> .....	<b>NOTES</b>

### Proposition 65 Warning

Engine exhaust from this product contains chemicals known to the State of California to cause cancer, birth defects, and other reproductive harm

© COPYRIGHT 2005, TEXTRON INC.

"All rights reserved, including the right to reproduce this book or portions thereof in any form".

All information in this publication is based on information available at time of approval for printing. Jacobsen reserves the right to make changes at any time without notice and without incurring any obligation.

LITHO IN U.S.A. 3-2005

## 2.1 OPERATING SAFETY



### WARNING

#### EQUIPMENT OPERATED IMPROPERLY OR BY UNTRAINED PERSONNEL CAN BE DANGEROUS.

Familiarize yourself with the location and proper use of all controls. Inexperienced operator's should receive instruction from someone familiar with the equipment before being allowed to operate the machine.

1. Safety is dependent upon the awareness, concern and prudence of those who operate or service the equipment. Never allow minors to operate any equipment.
2. It is your responsibility to read this manual and all publications associated with this equipment (Parts & Maintenance manual, engine manual, accessories and attachments). If the operator can not read English it is the owner's responsibility to explain the material contained in this manual to them.
3. Learn the proper use of the machine, the location and purpose of all the controls and gauges before you operate the equipment. Working with unfamiliar equipment can lead to accidents.
4. Never allow anyone to operate or service the machine or its attachments without proper training and instructions; or while under the influence of alcohol or drugs.
5. Wear all the necessary protective clothing and personal safety devices to protect your head, eyes, ears hands and feet. Operate the machine only in daylight or in good artificial light.
6. Evaluate the terrain to determine what accessories and attachments are needed to properly and safely perform the job. Only use accessories and attachments approved by Jacobsen.
7. Stay alert for holes in the terrain and other hidden hazards.
8. Inspect the area where the equipment will be used. Pick up all the debris you can find before operating. Beware of overhead obstructions (low tree limbs, electrical wires, etc.) and also underground obstacles (sprinklers, pipes, tree roots, etc.) Enter a new area cautiously. Stay alert for hidden hazards.
9. Never allow anyone near the machine while in operation. The owner/operator can prevent and is responsible for injuries inflicted to themselves, to bystanders and damage to property.
10. Do not carry passengers. Keep bystanders and pets a safe distance away.
11. Never operate equipment that is not in perfect working order or is without decals, guards, shields or other protective devices securely fastened in place.
12. Never disconnect or bypass any switch.
13. Do not change the engine governor setting or overspeed the engine
14. Carbon monoxide in the exhaust fumes can be fatal when inhaled. Never operate the engine without proper ventilation or in an enclosed area.
15. Fuel is highly flammable, handle with care.
16. Keep the engine clean. Allow the engine to cool before storing and always remove the ignition key.
17. Place transmission in neutral, depress clutch and engage parking brake before starting the engine (motor). Start the engine only when sitting in operator's seat, never while standing beside the unit.
18. Equipment must comply with the latest federal, state, and local requirements when driven or transported on public roads. Watch out for traffic when crossing or operating on or near roads.
19. Local regulations may restrict the age of the operator.
20. Operate the machine up and down the face of the slopes (vertically), not across the face (horizontally).
21. To prevent tipping or loss of control, do not start or stop suddenly on slopes. Reduce speed when making sharp turns. Use caution when changing directions.
22. Always use the seat belt when operating vehicles equipped with a ROPS.  
*Never use a seat belt when operating vehicle without a ROPS.*
23. Keep legs, arms and body inside the seating compartment while the vehicle is in motion.

## 2 SAFETY

---

### 2.2 IMPORTANT SAFETY NOTES

---



*This safety alert symbol is used to alert you to potential hazards.*

**DANGER** - Indicates an imminently hazardous situation which, if not avoided, WILL result in death or serious injury.

**WARNING** - Indicates a potentially hazardous situation which, if not avoided, COULD result in death or serious injury.

**CAUTION** - Indicates a potentially hazardous situation which, if not avoided, MAY result in minor or moderate injury and property damage. It may also be used to alert against unsafe practices.

*For pictorial clarity, some illustrations in this manual may show shields, guards or plates open or removed. Under no circumstances should this equipment be operated without these devices securely fastened in place*



#### **WARNING**

The Interlock system on this vehicle prevents the vehicle from starting unless the clutch pedal is depressed.

NEVER operate vehicle unless the Interlock system is working.



#### **WARNING**

1. Before leaving the operator's position for any reason:
  - a. Remove foot from accelerator pedal.
  - b. Slow vehicle using service brake.
  - c. Depress clutch and shift transmission to neutral.
  - d. Engage parking brake.
  - e. Stop engine and remove the ignition key.
2. Keep hands, feet, and clothing away from moving parts. Wait for all movement to stop before you clean, adjust or service the machine.
3. Keep the area of operation clear of all bystanders and pets.
4. Never carry passengers, unless a seat is provided for them.

By following all instructions in this manual, you will prolong the life of your machine and maintain its maximum efficiency. Adjustments and maintenance should always be performed by a qualified technician.

If additional information or service is needed, contact your Authorized Jacobsen Dealer who is kept informed of the latest methods to service this equipment and can provide prompt and efficient service. **Use of other than original or authorized Jacobsen parts and Accessories will void the warranty.**

### 2.3 CHEMICAL HANDLING, USE AND STORAGE

---

Chemicals are used in this sprayer and used in cleaning after use. A manufacturer's MSDS (Material Safety Data Sheet) must be obtained from the chemical supplier for each chemical, and a copy kept near the area that the chemical is stored and used. Information listed on the MSDS are the chemical characteristics and hazards associated with its use. Special attention should be given to recommended safety equipment, first aid treatment for accidental inhalation, swallowing, absorption or injection and compatibility with other chemicals. All sprayer employees should know how to read a MSDS.

Use care when opening sprayer tank cover. Potentially dangerous chemical fumes may have accumulated inside tank.

Chemicals and cleaning solutions may be flammable or produce flammable vapors. Do not smoke when working with chemicals. Never store chemicals near an open flame or spark which could ignite chemicals or chemical vapors.

Never work with harmful chemicals alone. Always have a second person nearby in case of emergency.

## 2.4 RECOMMENDED SAFETY EQUIPMENT

Special safety equipment is required to prevent accidental exposure to poisoning and should be worn at all times when working with chemicals. Contact your chemical supplier for proper material handling and compatibility.

The following is strongly recommended, however other safety equipment may be required. Always refer to the chemical manufacturers MSDS (Material Safety Data Sheet), that is available for all chemicals for additional safety equipment that may be required.

**Mask / Respirator** - Prevents inhalation of harmful fumes. Use an approved canister type with appropriate filter cartridges for chemical being used

**Spray Suit** - Full coverage for arms, legs and body, free from rips or tears.

**PVC / Nylon Gloves** - Protect hands and sleeve openings.

**Goggles** - To cover eyes / glasses for better protection.

**Face Shield** - To prevent accidental facial contact with chemicals.

## 2.5 WORK AREA SAFETY RECOMMENDATIONS

**Read this section carefully and thoroughly in order to become familiar with the proper safety techniques used when operating the sprayer.**

Be sure to obtain an operation demonstration from your Jacobsen dealer before attempting to operate this vehicle.

The operator must be familiar with the function of all vehicle controls as well as the operating characteristics of the vehicle. This is best accomplished through careful application of proper operating procedures.

**The safety of the operator and bystanders depend on your good judgement in operating and maintaining this vehicle.**

### **WARNING**

**DO NOT** operate this equipment until you have read the operators manual completely. Operators must be confident and sure of their skills before operating this unit. Only properly trained persons with proper safety equipment should be allowed to operate this vehicle.

Use caution when operating on slopes, turning and braking. Avoid full throttle starts. The large liquid payload reacts differently during vehicle movement, than an equal sized dry load. This is heavy equipment that could cause serious injury or death to the operators and/or bystanders if used improperly or overturned.

Never allow minors to operate the vehicle at any time.

1. It is recommended that all spray technicians obtain a CPA (Certified Pesticide Applicators) license or equivalent. Operators should request, read and follow all appropriate local, state and federal

regulations pertaining to spraying equipment, chemical mixing and storage. Be informed, not a victim.

2. We recommend a run-off recovery or containment system for the mix and load area. If one is not available, be certain the run-off does not contaminate water supplies, public sewers or natural wet land areas. Check your local regulations for requirements in your area.
3. Do not allow non-sprayer personnel to enter the mix and load area. All mix and load operations should only be performed with proper safety equipment in place. Refer to the chemical manufacturers MSDS for required safety equipment, mixing and handling procedures.
4. Use an anti-backflow protection device on fill hoses and water source outlets, especially if using a public water system. An Air Gap Filler (anti-siphon) is available as an optional accessory for the Spraytek.
5. Never place fill hose into tank. This could contaminate the hose.
6. Keep hands, feet and other body parts away from moving components. Restrain loose clothing and use caution around moving parts.
7. Follow recommended safety and maintenance schedules for this equipment. Do not operate this equipment without safety devices in place or if the equipment is not working correctly.
8. Keeping proper records in regards to chemicals being used, batch size, time, date, areas treated, weather conditions and unusual occurrences can protect you and others should any problems occur after turf application has been made.

In case of an accident, injury or unprotected exposure, notify your supervisor immediately. If necessary, operator or supervisor should contact the poison control board, EPA, and / or local fire department to help with the situation.

### 3 VEHICLE IDENTIFICATION NUMBERS

#### 3.1 VEHICLE IDENTIFICATION NUMBER

The Vehicle Identification Number (VIN), consisting of the model number, date code and serial number are all printed on the Nameplate/Identification Decal attached to the cross member under the dash.

The serial number is also stamped on the cross member. It is located to the left of the Nameplate/Identification Decal.

**NOTE:** *Reference to the Front, Rear, Left and Right sides of the vehicle are always determined by the operator's seated position.*

Record the Vehicle Identification information below for easy reference.

Model Number: 84042 DS300

Date Code: \_\_\_\_\_

Serial Number: \_\_\_\_\_

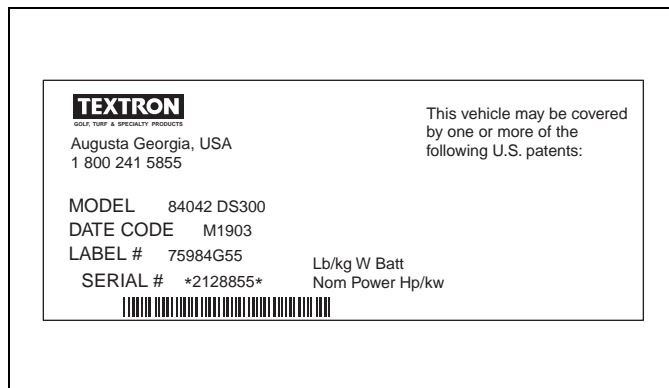

**Figure 3A**

Always provide the Vehicle Identification Number of the unit when ordering replacement parts or requesting service information. Vehicle Identification Numbers must appear on all correspondence concerning this vehicle.

#### 3.2 ENGINE IDENTIFICATION NUMBERS

The Spraytek DS-300 is equipped with a Perkins 3 cylinder, diesel powered, liquid cooled, four cycle engine.

The Engine Serial Number for the Perkins engine is stamped onto the engine block on the right side of the engine near the alternator.

Record the Engine Serial Number below for easy reference.

Engine Serial Number: \_\_\_\_\_

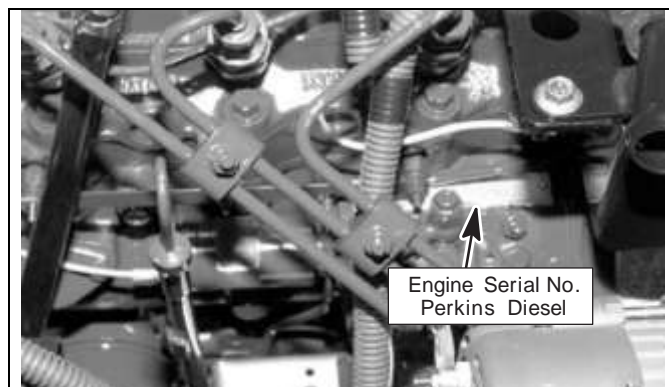

**Figure 3B**

#### 3.3 SDI SPRAYER TANK IDENTIFICATION NUMBERS

The model number and serial number for the sprayer tank is stamped on a name plate located on the front of the sprayer frame, directly above the fuel tank.

Record the Sprayer Identification information below for easy reference.

Model Number: \_\_\_\_\_

Serial Number: \_\_\_\_\_

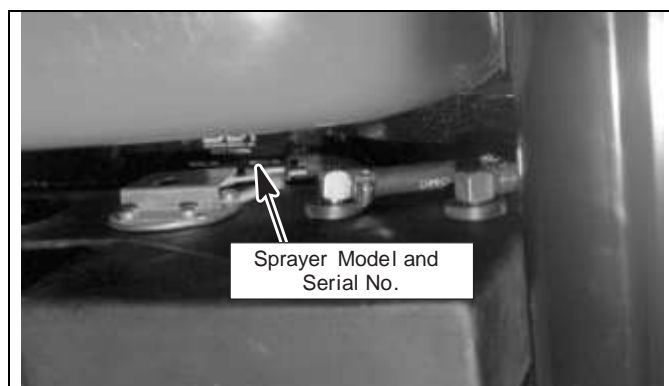

## 4.1 DECALS

Familiarize yourself with the decals. They are critical to the safe operation of the machine. REPLACE DAMAGED DECALS IMMEDIATELY.

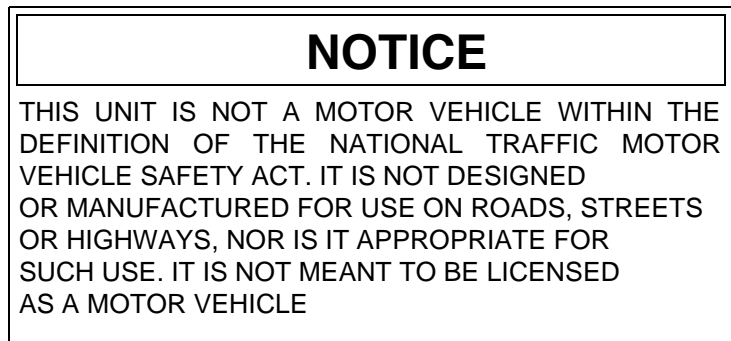

821071





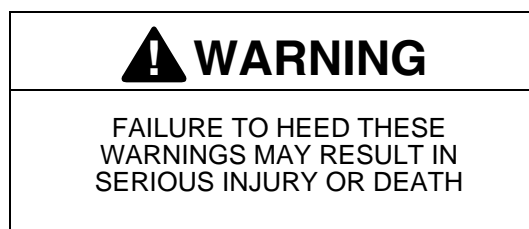









822819



Part of 845038

# 5 CONTROLS

## 5.1 ICONS

<p><b>Read Manual</b></p> 	<p><b>Hour Meter</b></p> 	<p><b>Engine Throttle</b> High      Low</p> 	<p><b>Ignition Switch</b> ACC      Off      ON      Start</p> 
<p><b>Coolant Temperature</b></p> 	<p><b>Brake</b> Parking    Service</p> 	<p><b>Fuel</b></p> 	<p><b>Governor Control</b> Throttle      Governor</p> 
<p><b>Glow Plug</b></p> 	<p><b>Turn Indicators</b> Left      Right</p> 	<p><b>High Beam</b></p> 	<p><b>Engine Oil Pressure</b></p> 

 <h3 style="margin: 0;">WARNING</h3> <p style="margin: 5px 0;">Never attempt to drive this vehicle unless you have read the Safety and Operation Manual and know how to operate all controls correctly.</p> <p style="margin: 5px 0;">Familiarize yourself with the icons shown above and what they represent. Learn the location and purpose of all the controls and gauges before operating this tractor.</p>
--

- A Tachometer
- B Hour Meter
- C Fuel Gauge
- D Voltmeter
- E Temperature Gauge
- F Turn Signal Indicator
- G Oil Pressure Light
- H Glow Plug Light
- J Service Brake Fluid Light
- K Parking Brake Light
- L High Beam Indicator
- M Ignition Switch
- N Gear Selector
- P Accessory Power Plug
- R Hand Throttle
- S Governor Control
- T Light Switch
- U Horn Button
- V Clutch Pedal
- W Service Brake Pedal
- X Accelerator Pedal
- Y Sprayer Control Mount
- Z Parking Brake Lever
- AA Differential Shift Cable
- AB Sprayer Pump Switch
- AC Agitation Control Handle
- AD Boom/Hose Supply Valve
- AE Boom Valve
- AF Supply Valve

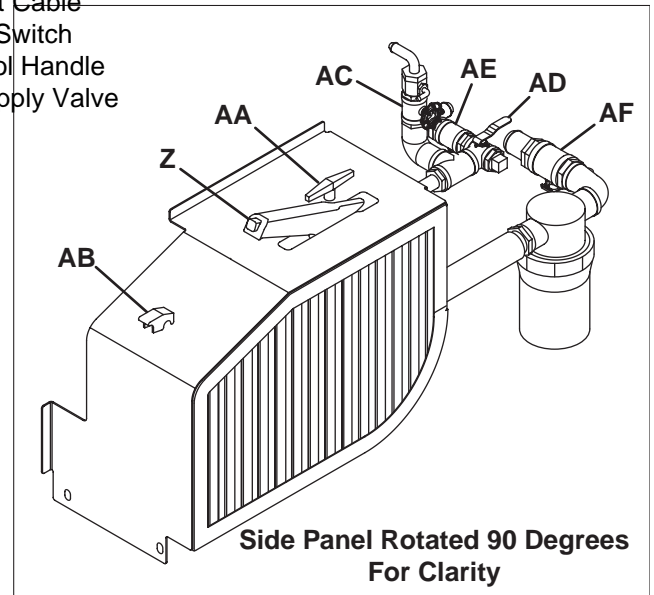
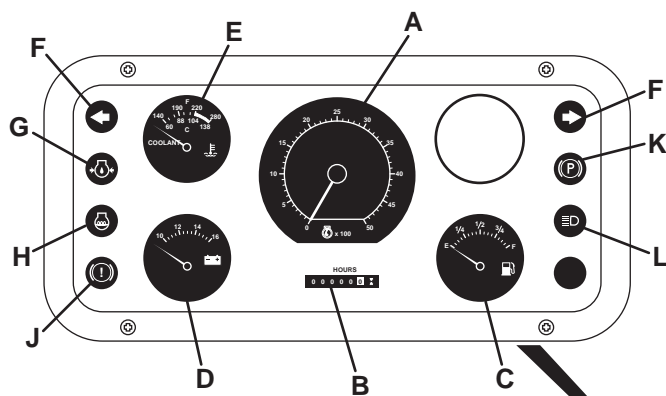

Side Panel Rotated 90 Degrees For Clarity

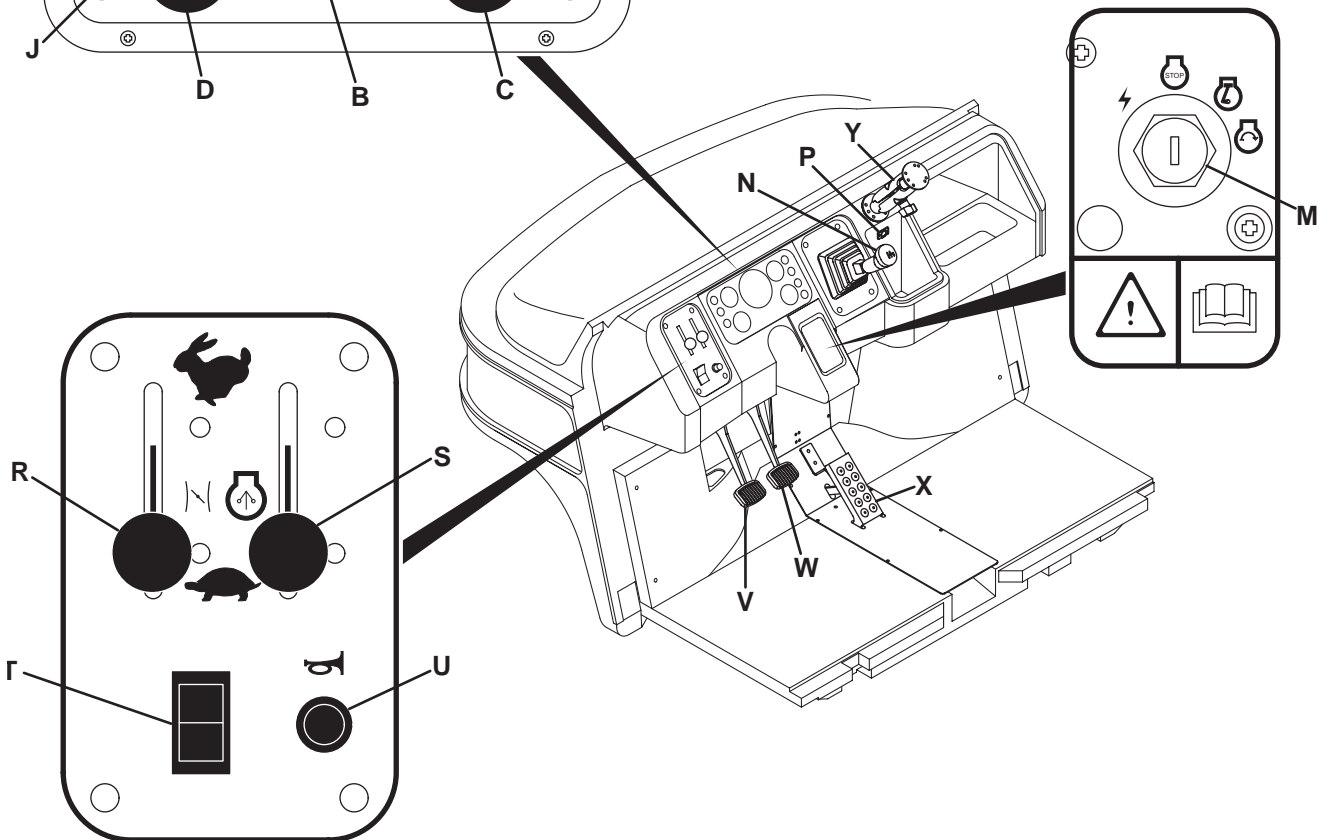

# 5 CONTROLS

## 5.2 CONTROL DESCRIPTIONS

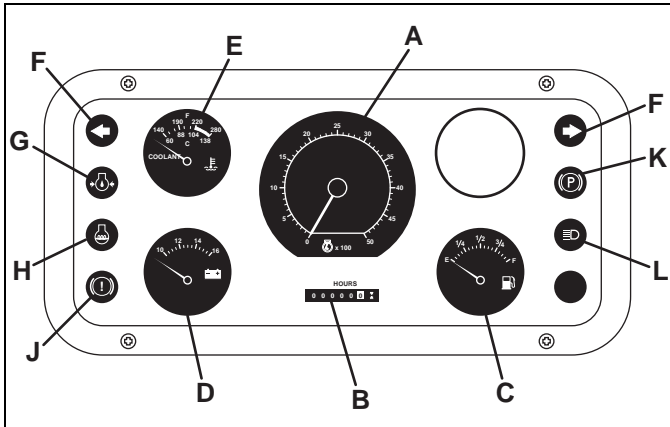

Figure 5A

- A. **Tachometer** - Indicates the engine speed (x 100) in revolutions per minute (rpm).
- B. **Hour Meter** - Records the number of hours the unit has been operated. The hour meter is active when the ignition switch (M) is in the ON position.
- C. **Fuel Gauge** - Indicates the amount of fuel remaining in the tank. Do not allow the tank to run dry.
- D. **Voltmeter** - The voltmeter indicates the voltage level of the battery. Under normal operation it should display between 12 and 18 volts. A reading below 12 volts indicates the battery is not charging correctly and is being drained
- E. **Water Temperature Gauge** - Indicates engine coolant temperature. If temperature rises above 230° F (110° C), a buzzer located under dash will sound.
- F. **Turn Signal Indicators** - Used with optional turn signal kit. Left or right indicators flash when turn signal lever is moved to left or right position. Both indicators will flash when hazard button is pressed.
- G. **Oil Pressure Light** - Light will come on when ignition switch is turned to on position and will go out once engine starts. Do not continue to operate truck if light does not go out, or comes on during operation.
- H. **Glow Plug Light** - Indicates glow plug timer is active. Timer will operate for approximately 20 seconds while pre-heating glow plugs in engine.
- J. **Service Brake Fluid Light** - Indicates low fluid level in master cylinder reservoir. Fill with clean DOT 3 brake fluid.

- K. **Parking Brake Light** - Indicates parking brake is engaged. Do not drive unit without disengaging parking brake.
- L. **High Beam Indicator** - Indicates light switch (T) is in high beam position.

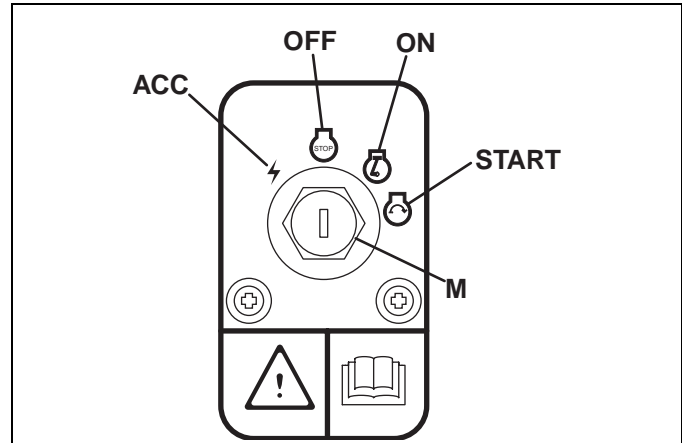

Figure 5B

- M. **Ignition Switch** - The ignition switch has four positions. ACC - OFF - ON - START.
  - ACC (Accessory) Position** - Allows use of various instruments and accessories without causing ignition system damage.
  - OFF Position** - Prevents function of all vehicle electrical power operated features except for the flasher (hazard), lights, and the radiator cooling fan. **Switch must be in OFF position for key removal.**
  - ON Position** - Key is placed in this position for normal engine operation.
  - START Position** - Hold key in start position to engage engine starter. Upon release, key will return to ON position automatically. Key must be returned to the OFF position before the starter can be reactivated.
- N. **Gear Selector** - The gear selector is used to shift transmission into desired gear. Refer to ground speed decal to determine required gear.  
Gear selector knob has the "H" shift pattern design molded into the top surface.

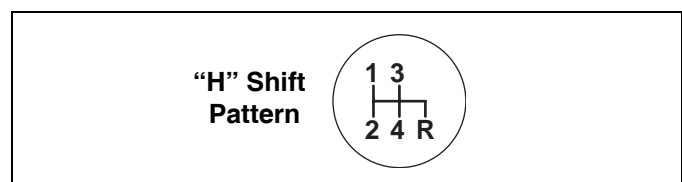

Figure 5C

**P. Accessory Power Plug** - Allows operation of approved 12 Volt accessories and attachments. To prevent excessive battery drain, only use 12 volt outlet with engine running.

**CAUTION**

The 12 Volt Accessory outlet circuit is protected by a 15 Amp fuse. Do not attempt to use attachment(s) with a combined power rating greater than 180 Watts.

To prevent the risk of burns or fire do not replace 15 amp fuse with a higher amperage rating fuse.

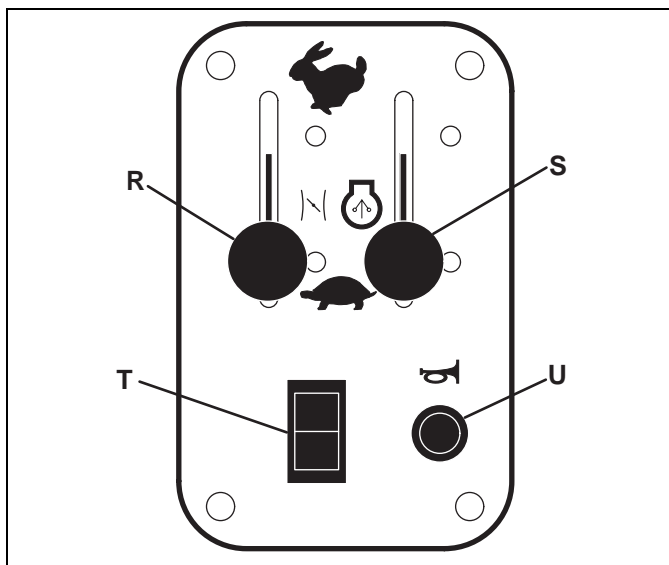

Figure 5D

- R. Hand Throttle** - Used to set engine speed for remote operations. Increasing hand throttle speed will depress accelerator pedal.  
Never attempt to drive the vehicle with the engine speed controlled by hand throttle.
- S. Governor Control** - Used to lower pre-set governor rpm limits for hand and foot throttle operation.  
Push lever all the way up to use pre-set rpm limit. Pull lever down as required to lower maximum rpm.
- T. Light Switch** - The light switch is used to turn the headlights and taillight on. The switch has three positions, OFF, LOW BEAM, and HIGH BEAM. Push switch up one detent for LOW BEAM or push switch up two detents for HIGH BEAM.
- U. Horn Button** - The horn button is located to the left of the steering wheel, below the dash panel. Depress to sound horn. Horn will not sound when the ignition switch is in the **OFF** position.

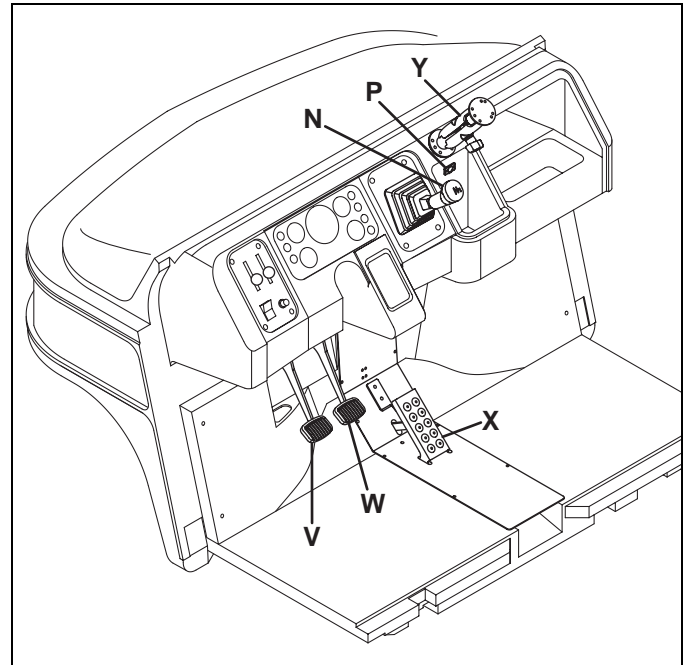

Figure 5E

- V. Clutch Pedal** - Used to disengage the power output from engine to transmission. This allows shifting of transmission gears. Do not attempt to shift gears without fully depressing clutch pedal.  
  
The clutch pedal is equipped with an interlock switch. This switch prevents the starter from operating unless the clutch is disengaged (the clutch pedal is depressed). See 6.2
- W. Service Brake Pedal** - Depress the pedal to slow or stop the vehicle.  
  
If the brakes DO NOT stop the vehicle properly, the brakes must be adjusted or repaired.
- X. Accelerator Pedal** - Push pedal down to open throttle (increase speed), release to return throttle to idle position (decrease speed).
- Y. Sprayer Control Mount** - Used to mount sprayer control.

## 5 CONTROLS

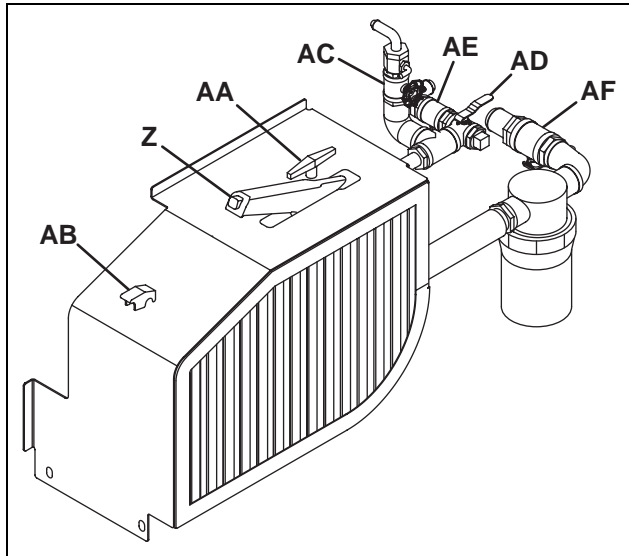

Figure 5F

**Z. Parking Brake Lever** - The park brake lever is located to the left side of the drivers seat. To engage the brake, pull up on the lever until park brake is applied.

To release; while slightly pulling up on the handle, push the button at the end of the lever and while holding the button in, lower the lever to it's original position.

**AA. Differential Shift Cable** - Used to shift differential from **LOW** to **HIGH** speed range.

Spraying operations must be performed with differential in **LOW** speed range

**AB. Sprayer Pump Switch** - Used to engage and disengage sprayer pump. Do not allow pump to be run dry. Permanent damage may result.

**AC. Agitation Control Handle** - Controls the amount of liquid passing through the nozzles allowing complete agitation for mixing loaded chemicals with carrier (water). It is recommended to leave this valve fully open at all times even with low tank liquid level.

**AD. Boom/Hose Supply Valve** - Allows isolated use of either the hose reel or the boom. The hose reel position allows hook-up to a hand-held spray gun or walking type spray boom. The boom position allows use of all spray boom accessories.

**AE. Boom Valve** - Needs to be open if the Boom/Hose Supply Valve (**AC**) is in the boom position, if the selector valve is in the hose reel position, this control valve needs to be in the closed position.

**AF. Suction Valve** - Needs to be in the open position for normal operation. If the pump and/or the filter need servicing or repair, this valve can be turned to the closed position (with liquid in the tank) allowing these items to be worked on.

### 5.3 SPRAYER CONTROL SYSTEMS

There are three different sprayer control systems that can be used with this sprayer. The sprayer control systems do not come with the Spraytek and must be ordered separately.

All information pertaining to the set-up and installation of the booms and control systems is furnished with the accessory.

**SDI Control System with Motorized Valve**

Jacobsen part number 4119052

1. Pressure Gauge (Boom Pressure)
2. Pressure Adjust Switch (Up/Down)
3. Master Boom (On/Off)
4. Boom 1 (Left Boom)
5. Boom 2 (Center Boom)
6. Boom 3 (Right Boom)
7. Power Switch
8. Foam Marker
9. Boom 1 Lift
10. Boom 2 Lift
11. Boom 3 Lift

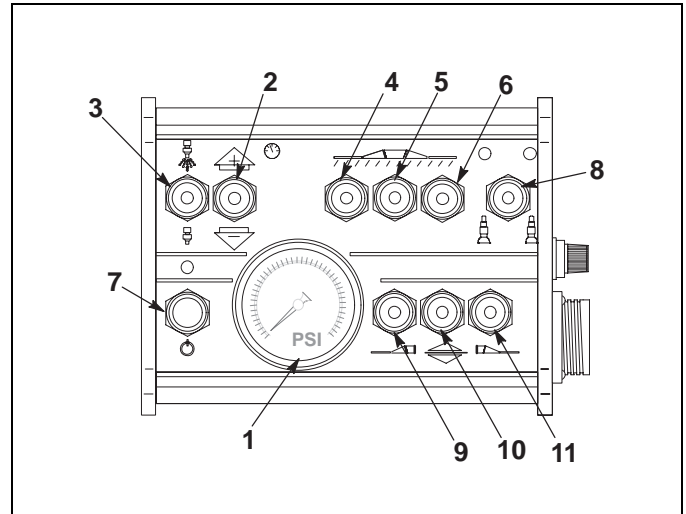

Figure 5G

**Raven SCS330 Control System with Motorized Valve**

Jacobsen part number 4119056

1. Master Boom (On/Off)
2. Boom 1 (Left Boom)
3. Boom 2 (Center Boom)
4. Boom 3 (Right Boom)
5. System Select Power Switch
6. Rate Adjust/Override Switch
7. Rate/Data LCD Screen
8. Data Input Keypad

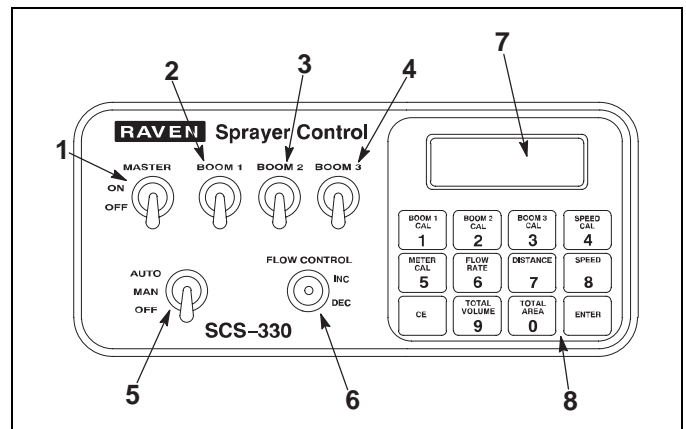

Figure 5H

**Raven SCS440 Control System with Motorized Valve**

Jacobsen part number 4119057

1. Master Boom (On/Off)
2. Boom 1 (Left Boom)
3. Boom 2 (Center Boom)
4. Boom 3 (Right Boom)
5. System Select Power Switch
6. Rate Adjust/Override Switch
7. Rate Selector Switch
8. Data Input Keypad
9. Data LCD Screen
10. Rate LCD Screen

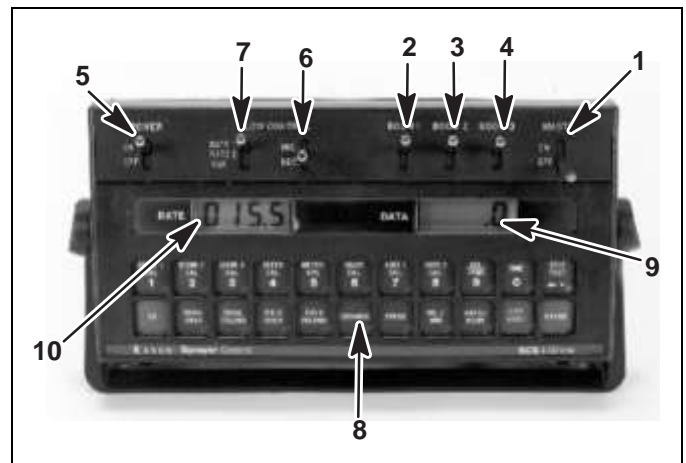

Figure 5I

## 6 OPERATION

---

### 6.1 DAILY INSPECTION

---

#### CAUTION

The daily inspection should be performed only when the engine is off and all fluids are cold. Lower mowers to the ground, engage the parking brake, Stop engine and remove ignition key.

1. Perform a visual inspection of the entire unit, look for signs of wear, loose hardware, and missing or damaged components. Check for fuel or oil leaks to ensure connections are tight and hoses and tubes are in good condition.

2. Check the fuel supply, radiator coolant level, crankcase oil and air cleaner indicator. All fluids must be at the full level mark with engine cold.
3. Make sure all mowers are adjusted to the same cutting height.
4. Check tires for proper inflation.
5. Test the Interlock System.

**Note:** For more detailed maintenance information, adjustments and maintenance/lube charts, see the **Parts & Maintenance** manual.

### 6.2 Interlock System

---

1. The Interlock System prevents the engine from starting unless the clutch pedal is depressed.

#### WARNING

Never operate equipment with the Interlock System disconnected or malfunctioning. Do not disconnect or bypass any switch.

Never turn the key to the START position unless the clutch pedal is depressed (pushed down) or the gear selector is in neutral. If the vehicle is in any gear other than neutral, and the clutch pedal is not depressed when the engine is started, the vehicle may lurch forward or backward depending which gear the vehicle is in. This lurching could cause serious personal injury or death.

2. Perform each of the following two tests to insure the Interlock System is functioning properly. Stop the test and have the vehicle inspected and repaired if truck **fails** either test.

- the engine **does not** start in test 1;
- the engine **does** start during tests 2;

3. Performed actions described for each test. Shut engine off between each test.

**Test 1:** Represents normal starting procedure. The clutch pedal is depressed. The engine should start.

**Test 2:** The engine must not start if the clutch pedal is not depressed.

### 6.3 OPERATING PROCEDURES

#### WARNING

A Rollover Protection Structure (ROPS) for this truck is available as an optional accessory. Evaluate the terrain and working conditions to determine if a ROPS is required. Seat belts must be worn whenever a ROPS is installed on the tractor. Always keep seat belt snugly adjusted. **DO NOT** use seat belts on a tractor without a ROPS.

If a ROPS is installed and the tractor is overturning, hold onto the steering wheel. Do not attempt to jump out or leave the seat.

#### CAUTION

To prevent injury, always wear safety glasses, leather work shoes or boots, a hard hat, and ear protection. Wear any protective equipment recommended by the chemical manufacturer.

1. Under no circumstances should the engine be started without the operator seated on the truck.
2. Do not operate truck or attachments with loose, damaged or missing components. Whenever possible spray when grass is dry.
3. Never remove or install the engine cover while the engine is running. The engine cover is a *machinery guard* and its removal exposes you to moving parts. Keep hands, hair and clothing away from flywheel, radiator cooling fan, alternator fan, engine belts, pulleys and air intake.
4. First spray using water in a test area to become thoroughly familiar with the operation of the truck and sprayer.
5. Study the area to determine the best and safest operating procedure. Consider the type of terrain, and condition of the surface. Each condition will require certain adjustments or precautions.
6. Never direct discharge of material toward bystanders, nor allow anyone near the machine while in operation. The owner/operator is responsible for injuries inflicted to bystanders and/or damage to their property.
7. Always turn pump switch off when not spraying.
8. Disengage the sprayer pump and raise the booms when crossing paths or roadways. Look out for traffic.
9. Stop and inspect the equipment for damage immediately after striking an obstruction or if the machine begins to vibrate abnormally. Have the equipment repaired before resuming operation.

#### WARNING

Failure to latch the engine cover properly can result in the engine cover tipping forward causing loss of control of the vehicle and possible personal injury.

#### WARNING

Before you clean, adjust, or repair this equipment, always disengage sprayer pump, lower booms to the ground, engage parking brake, stop engine and remove key from ignition switch to prevent injuries.

10. Slow down and use extra care on hillsides. Read Section 6.9. Use caution when operating near drop offs.
11. Look behind and down before backing up to be sure the path is clear. Use care when approaching blind corners, shrubs, trees or other objects that may obscure vision.

#### CAUTION

Before spraying, pick up all debris such as rocks, toys and wire which can be thrown by the machine. Enter a new area cautiously. Always operate at speeds that allow you to have complete control of the sprayer.

## 6 OPERATION

### 6.4 STARTING

**IMPORTANT: Do not use starting assist fluids.** Use of such fluids in the air intake system may be potentially explosive or cause a “Runaway” engine condition and could result in serious engine damage.

1. Make sure fuel shut off valve is completely open.
2. Sit in operator's seat, make sure the parking brake is engaged and transmission is in neutral. [See 5.2]
3. Depress clutch pedal. [See 5.2 and 6.2]
4. Turn ignition switch (M) to **ON** position.
  - a. Engine Oil light (G) will come on and will stay on until engine starts.
  - b. Glow plug light (H) will come on for up to 20 seconds.
  - c. Parking brake light (K) will be on when parking brake is engaged.
5. The diesel engine uses glow plugs to pre-heat the combustion chamber and makes cold starting easier. When starting the vehicle for the first time during the day, or when the engine has cooled, you will need to energize the glow plugs to start the engine. Energizing glow plugs is not necessary when starting a warm engine.
6. When glow plug light (H) turns off, turn key (M) to **START** position. Release as soon as engine starts. Do not hold switch in the **START** position for more than 15 seconds. Make sure engine oil light (G) turns off.
7. Allow the engine to become warm and properly lubricated before operating at high RPM.

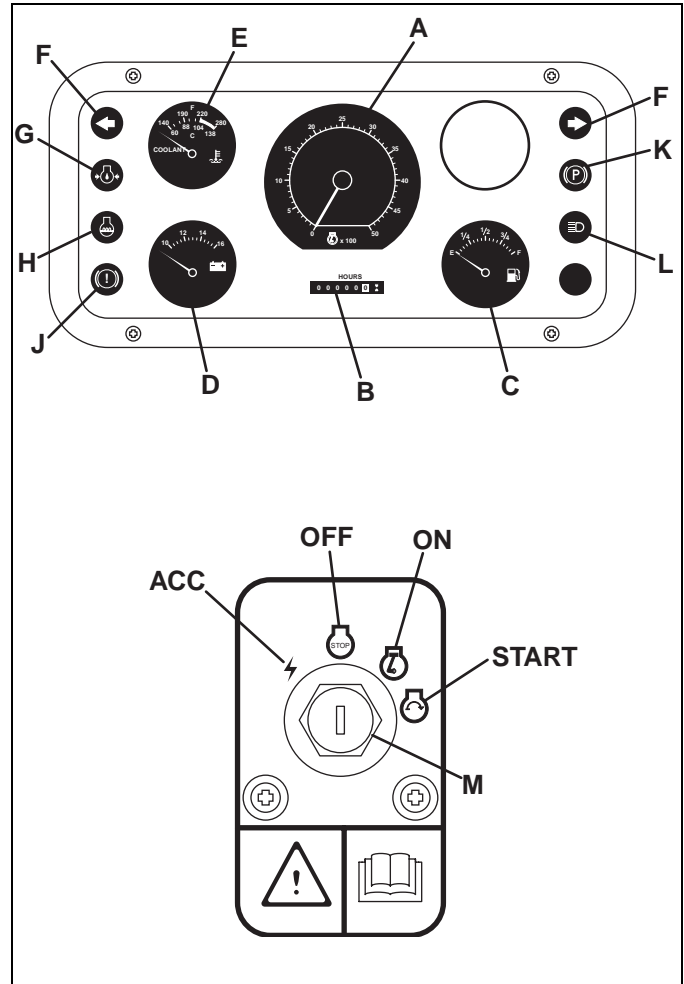

Figure 6A

### 6.5 PARKING

**To park the tractor under normal conditions:**

1. Disengage the sprayer pump switch, raise the booms and move away from the area of operation.
2. Select a flat and level area to park.
  - a. Remove your foot from foot throttle, apply service brake and depress clutch pedal.
  - b. Once vehicle has stopped, shift transmission to neutral and apply the parking brake. Allow engine to operate at no load for a minute.
3. Stop the engine and always remove the ignition key.

If an emergency arises and the truck must be parked in the area of operation, follow the guidelines outlined by the grounds superintendent. If the truck is parked on an incline, chock or block the wheels.

## 6.6 TO DRIVE VEHICLE

Read and follow all safety notes contained in this manual when driving vehicle. Refer to Section 6.3 for general operating instructions. When operating in reverse look behind you to ensure you have a clear path.

**Important:** If this truck is driven on public roads, it must comply with federal, state and local ordinances. Contact local authorities for regulations and equipment requirements.

1. Disengage sprayer pump switch and raise booms to when driving to and from the area of operation.
2. Apply service brake and disengage parking brake.
3. The gear selector has an "H" pattern as shown in (there is also a shift-pattern design molded into the top of the gear selector handle).
4. With the clutch pedal fully depressed, select the appropriate gear (forward or reverse), release the clutch pedal slowly while depressing the throttle pedal.

**NOTE:** *As you release the clutch pedal you will notice after the pedal has been partially released the vehicle will begin to move. When the vehicle begins to move, depress the throttle a little more and at the same time*

*keep releasing the clutch pedal. **DO NOT drive with the clutch pedal partially depressed.***

5. When the vehicle gains enough speed, depress the clutch pedal and shift to the next higher gear and so on. When you shift gears remember that as you push in the clutch you need to release the throttle pedal. **DO NOT** push in the accelerator at the same time you are pushing in the clutch while shifting to a higher or a lower gear (downshifting).
6. You can down-shift from fourth to third and from third to second and so on while the vehicle is moving and the engine's speed is decreasing.

**NOTE:** *Only downshift if the vehicle is at a complete stop or if the engine's speed is decreasing.*

Remember, before shifting to any gear you have to depress the clutch pedal before you shift to that particular gear.



### CAUTION

To prevent tipping or loss of control, travel at reduced speed when making turns.

## 6.7 ENGINE OVERHEAT PROCEDURE

During vehicle operation, if the water temperature gauge shows 230° F (110° C) or above, and/or the overheat warning buzzer sounds, follow this procedure.

1. **Stop** the vehicle. **DO NOT shut the engine off.** Place vehicle in neutral and engage the parking brake.
2. Immediately disengage any accessories that are operating.
3. Slow the engine speed to a fast idle.
4. Remove any dirt, chaff, debris, etc. from the radiator intake screen located on the right side of the vehicle.



### CAUTION

Be careful when opening the engine access cover or cleaning the intake screen. Metal surfaces near the radiator and engine may be hot to the touch. Use a brush or gloves to clean screen.

temperature does not go down, STOP the engine and check the following.

1. Check to see if cooling fan is operating. Fan should be turning with coolant above 180° F, even with ignition switch in OFF position.
2. Check engine oil level.
3. Check for a leak in the cooling system. **Do not** open radiator when hot. Check coolant levels after system completely cools.

Failure to heed the overheat warning and properly maintain the cooling system will cause permanent engine damage.

Temperature gauge needle should start to go down approximately 30 seconds after the screen is cleaned. If

## 6 OPERATION

### 6.8 TOWING THE VEHICLE

#### **WARNING**

To prevent injury or vehicle damage, the following guidelines should always be followed.

- **Never** accelerate or stop suddenly when towing a vehicle.
- **Never** change the direction of the vehicle abruptly or make sharp turns on an incline when towing a vehicle.
- **Never** tow the vehicle faster than 5 m.p.h. (8 km/h). Towing at excessive speed could cause either vehicle to lose proper steering control
- Adjust your speed for weather and surface conditions when towing (rain, snow, ice, hills, etc.).

If for any reason the vehicle needs to be towed, follow the procedures below.

1. If towing the vehicle with a tow-rope or chain, an operator is required to steer the vehicle and to control the brakes.
2. Attach a tow-roper only to the front vertical frame member on either side of the vehicle.
3. Shift transmission to Neutral and release parking brake.

4. Slowly drive towing vehicle forward until tow-line is pulled tight.
5. While towing, try to keep the tow light taught at all times. Be careful going down inclines and turning corners.

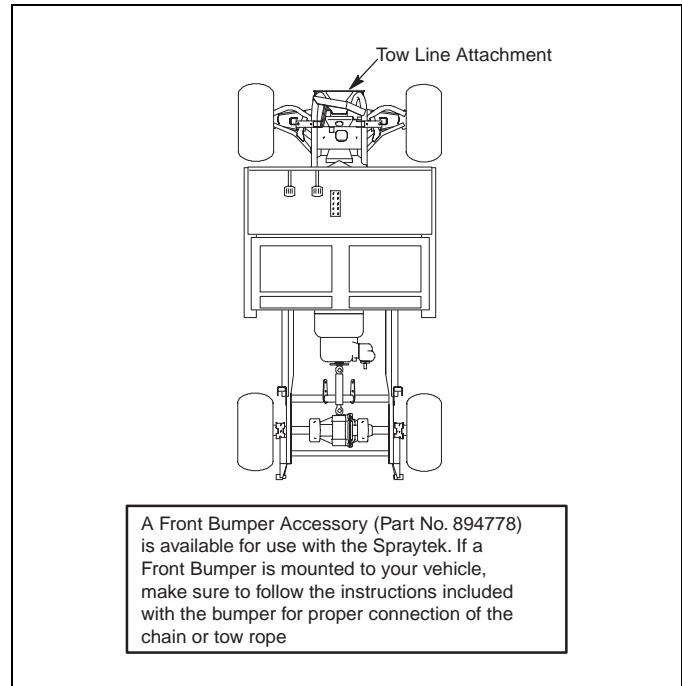

**Figure 6B**

### 6.9 HILLSIDE OPERATION

#### **WARNING**

To minimize the possibility of overturning, the safest method for operating on hills and terraces is to travel up and down the face of the slope (vertically), not across the face (horizontally). Avoid unnecessary turns, travel at reduced speeds, stay alert for hidden hazards, and drop offs. The large liquid payload reacts differently during vehicle movement, than an equal sized dry load. Liquid moving inside the tank can cause an unbalanced load that could tip the vehicle. This is heavy equipment that could cause serious injury or death to the operators and/or bystanders if used improperly or overturned.

The truck has been designed for good traction and stability under normal operating conditions; however, use caution when operating on slopes, especially over rough terrain or when the grass is wet. Wet grass reduces traction and steering control.

1. If the vehicle tends to slide or the tires begin to “mark” the turf, angle truck into a less steep grade until traction is regained or tire marking stops.
2. If vehicle continues to slide or mark the turf, the grade is too steep for safe operation. Do not make another attempt to climb, back down slowly.
3. When descending a steep slope, always lower implements to the ground to reduce the risk of tractor overturning.
4. Correct tire pressure is essential for maximum traction. **[See 6.10]**
5. Use caution when changing speeds and/or direction on slopes. The large liquid payload reacts differently during vehicle movement. Liquid moving inside the tank can cause an unbalanced load that could tip the vehicle.

## 6.10 TIRE PRESSURE

Keep tires properly inflated to prolong tire life. Check inflation pressure while the tires are cool. Inspect tread wear.

Lower pressure will help avoid leaving tire marks in soft turf. Higher pressures may be required for heavier loads. Rear tire pressure must be set at 28 psi (193 kPa) when operating with a full 300 gallon load. *Never* exceed the maximum pressure indicated on the tire.

Check the pressure with an accurate, low pressure tire gauge. Due to the low volume of air needed, over-inflation may be reached in a matter of two to three seconds.

Keep tires inflated to:

Front - 20 psi - (138 kPa)

Rear - Varies, determined by load. (See Chart)

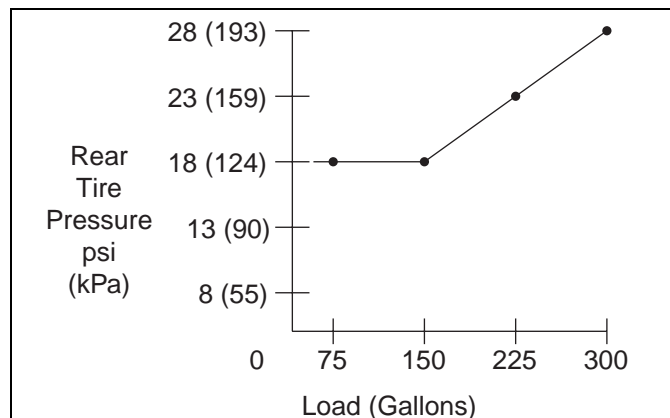

Figure 6C

## 6.11 DAILY MAINTENANCE

**Important:** For more detailed maintenance information, adjustments and maintenance/lubrication charts, see the **Parts & Maintenance** manual.

- Park the truck on a flat, level surface. Engage parking brake, stop the engine and remove key from ignition switch.
- Grease and lubricate all points if required. To prevent fires, wash truck after each use.
  - Use only fresh water for cleaning your equipment.

**Note:** *Use of salt water or affluent water has been known to encourage rust and corrosion of metal parts resulting in premature deterioration or failure. Damage of this nature is not covered by the factory warranty.*

- Do not use high pressure spray.
- Do not spray water directly at the instrument panel, or any electrical components.
- Do not spray water into the cooling air intake or the engine air intake.

**Note:** *Do not wash a hot or running engine. Use compressed air to clean the engine and radiator fins.*

- Fill tractor's fuel tank at the end of each operating day to within 1 in., (25 mm) below the filler neck.

Use clean, fresh #2 diesel fuel. Minimum Cetane Rating 45.

- Handle fuel with care - it is highly flammable. Use an approved container, the spout must fit inside the

fuel filler neck. Avoid using cans and funnels to transfer fuel.

- Never remove the fuel cap from the fuel tank, or add fuel, when the engine is running or while the engine is hot.
  - Do not smoke when handling fuel. Never fill or drain the tank indoors.
  - Never overfill or allow the tank to become empty. Do not spill fuel. Clean any spilled fuel immediately.
  - Never handle or store fuel containers near an open flame or any device that may create sparks and ignite the fuel or fuel vapors.
- Store fuel according to local, state or federal ordinances and recommendations from your fuel supplier.
  - Check the engine oil at the start of each day, before starting the engine. If the oil level is low, remove the oil filler cap and add oil as required. Do not overfill.



## 7.2 CONTROL VALVES

The control valves for determining which accessory to use are located on the left side of the vehicle directly behind the operators seat.

The agitator control handle controls an eight jet nozzle assembly in the lower tank sump area. This handle controls the amount of liquid passing through the nozzles allowing complete agitation for mixing loaded chemicals with carrier (water). It is recommended to leave this valve fully open at all times even with low tank liquid level.

The hose reel and boom valve allows isolated use of either the hose reel or the boom. The hose reel position allows hook-up to a hand-held spray gun or walking type spray boom. The boom position allows use of all spray boom accessories.

The boom control valve needs to be open if the hose reel & boom selector valve is in the boom position, if the selector valve is in the hose reel position, this control valve needs to be in the closed position.

The suction valve needs to be in the open position for normal operation. If the pump and/or the filter need servicing or repair, this valve can be turned to the closed position (with liquid in the tank) allowing these items to be worked on.

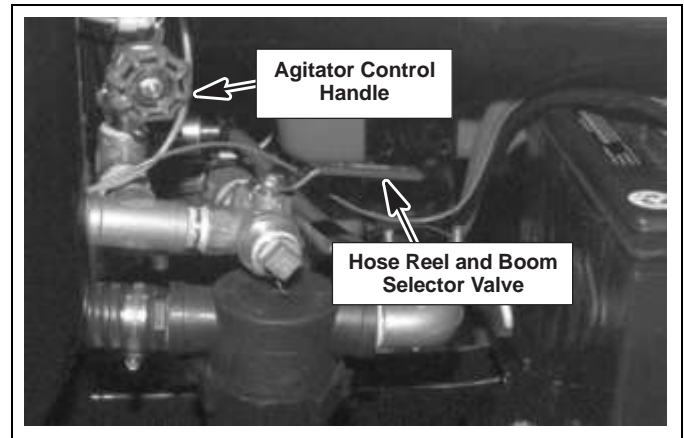

Figure 7A

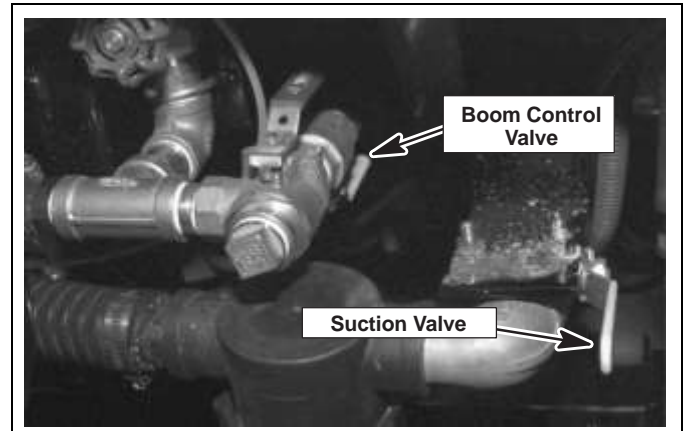

Figure 7B

## 7.3 SYSTEM DYNAMICS

The sprayer pump is belt driven off the engine. Electrical power for the sprayer is supplied by the vehicle battery.

The sprayer to truck mounting style makes the two systems act as one complete machine.

### **WARNING**

DO NOT operate sprayer pump with out liquid present in the system. Mechanical seals must be constantly lubricated with cool circulating liquid (spray mix). Running the system dry will heat up the ceramic seat and the addition of a cool liquid to a hot/dry seal will cause the ceramic to crack.

**Centrifugal Pump Lubrication** - lubrication for the impeller inside the pump housing (volute) is your spray liquid. This liquid lubricates the mechanical seal (made of ceramic and graphite rings) that are around the impeller shaft. The pump rotation creates heat, so the liquid is also needed for cooling.

The centrifugal pump is lubricated by the spray material therefore, the use of certain materials may affect maintenance or operation techniques.

**Venturi-Jet Agitator Nozzles** - installed with ceramic metered orifices (ceramic is a longer lasting material in comparison to plastic). Long lasting ceramic orifices provide stable agitation flow rates for trouble-free fluid mixing.

**Suction Strainer** - provides liquid filtering of particulate matter in spray material. Screen mesh sizes available are: 20, 50, 80 and 40 (standard) in SST material. The suction strainer (filter) should be cleaned daily or more often as the need arises. Remember to close the suction ball-valve (if liquid is in the tank) before removing the strainer.

**Non-Corrosive Plumbing** - all sprayer plumbing is SST, nylon or PVC, or polypropylene for all liquid handling parts.

# 7 SPRAYER OPERATION

---

## 7.4 SPRAYER SYSTEM CHECK

---

Before operating the Spraytek, the following components should be checked to ensure proper operation of sprayer.

### 1. Sprayer Tank and Tank Frame

- Inspect frame for broken welds and cracks. Make sure all mounting hardware is properly tightened.
- Inspect sprayer tank for cracks or leaks
- Inspect the lid and gasket for warpage or leaks. Clean any dirt or other debris from lid threads and gasket. Apply a light lubricant to gasket (such as silicon spray).
- Check lid check vent. Remove any residue from ball and seat. Check hinge pin.
- Remove lid and strainer basket. Visually inspect the interior of the tank for flaking or residue build up. Check anti-vortex plate in sump area for debris. Blocked suction can cause damage to the pump.
- Check jet agitator venturi nozzle position. Aim as necessary for proper agitation.
- Check ceramic orifices in agitator nozzles for cracks or blockage. Improperly functioning orifices can lead to reduced agitation and possible mixing problems.

### 2. Sprayer Pump

- Inspect suction and pressure hose for cracks or any damage that could cause a leak.
- Check pump for seal leakage at rear weep holes around rear shaft bearing.
- Check plastic vent tube from top of pump for kinks or dried powder products.
- Inspect and clean suction strainer screen.
- Inspect bowl and gasket. Improper gasket seating can result in poor pump performance. If necessary, replace gasket before operating unit. During bowl replacement, install bowl and tighten hand tight. **DO Not** use tools to tighten bowl.
- Between loads, wipe bowl with rag to maintain clarity.
- Check to be sure suction ball valve is open and free from damage.
- Make sure agitation valve is fully open. Due to the unique design of the tank sump and anti-vortex area, turning the agitation down or off with low fluid level in tank is not required.

### 3. Spray Boom

- Inspect support frame and mounting hardware for loose, damaged or missing components. Repair or replace if required before operating Spraytek.
- Adjust return spring tension for stiffer or looser action. With vehicle tires properly inflated for load and tank full of water, make sure boom is level and adjusted to the proper height (See Boom Accessory instructions for adjustments).
- Grease boom hinges (Breakaway booms) and remove any debris which may have accumulated on and around the pivot plate area.
- Inspect boom end caps for cracks or leaks. Repair as required.
- Between spray loads, check and clean all boom nozzle assemblies. Inspect check valve diaphragms for tears or warpage. Check and clean tips with a soft nylon brush (DO NOT use metal or hard brushes, tip damage will occur). Clean strainer screens and tip gaskets. Replace worn or damaged items as needed. Proper tip maintenance will result in optimum performance and pattern development.

### 4. Boom Control Systems

The Spraytek will have one of the following control systems. Identify which system is used on your machine.

#### Motorized Boom Controls:

- Check battery connections for proper pole hook-up (+ / -). Make sure all wires connected to the clips and their fasteners are tight.
- Check control box mount and console wing nuts for tightness. Clean dirty console with a damp cloth (mild soap), Do Not use solvents to clean the console!
- Check all toggle switches for play and replace as needed. If switches are rubber booted, check boots for cracks or tears and replace as necessary.
- Check control console pressure gauge bezel (clear plastic ring which holds gauge into console). The raised tabs should be in the 6 and 12 o'clock positions.
- Check back side of console and make sure power & control cables are locked into the pin connectors. Replace the rubber boot if it shows signs of excessive wear or cracking.
- Check fuse and rubber boot.

- Check plastic pressure gauge tube for kinks, breaks or blockage, repair as needed. To clear a blocked tube (packed with dry powder):
  - a. Put some clean water in the spray tank, 2 to 5 gallons (7.6 to 18.9 L) is sufficient. Turn sprayer on and set rpm's to 3000 on truck.
  - b. On the back-side of the console is a metal tube receiver with an 1/8" tube engaged. Push the tube and top of the metal coupler in with your thumb and index finger, while holding the metal ring in, pull the tube out with your other hand. Point end of tube away from unit and your face and allow debris to clear from tube.
  - c. If unsuccessful, remove other end of tube from Boom Valve inlet. Use a rubber tipped air nozzle to force high pressure air through the tube. If still unsuccessful, replace the tube with a new piece and start flushing the new tube after each spray application.
- Move back to the boom area at the rear of the sprayer. Inspect the connector plugs on the motorized valve harness, they should be tight against the valve body tighten if necessary (there should be no prongs showing from the valve).
- Check valve mating joints (seams) for leakage. if a leak is detected, tighten the nuts on the 4 guide rod bolts (there are o-rings in each joint area, Do Not tighten too tight. If the leak persists, separate the valve bodies and replace the o-rings with new ones.
- Make sure the U-clips on the boom feed barbs and metered by-pass valve are pushed in and secured (leakage can result if U-clips are not in place).
- Follow the boom hoses from each motorized valve to the corresponding boom section, make sure the brass compression clamp (pipe saddle feeder) with the nylon fitting is snug against the SST tube and the pipe saddle is parallel to the ground (improper saddle alignment can cause reduced flow during large tip use, adjust as necessary).

Move to the control console, Listen carefully as you perform the next series of checks.

- Push up on the pressure-adjust toggle switch, the Servo motor on the yellow striped valve should run. Reverse toggle switch position, verify motor works in both directions.
- Push the master power toggle to the "ON" position, check the switches one-at-a-time for boom 1, then boom 2, then boom 3, checking switches in both directions. Verify each blue striped valve works in both directions.

## **Raven SCS330 and SCS440 Boom Control System**

- Procedures are similar to the motorized valve control, refer to the manual supplied with the Raven Accessory for test procedures.
  - Wipe any debris from the console using a damp rag and mild soap.
  - Verify your pre-set calibration numbers, do they match your records sheet in the Raven Manual? Modify any numbers that do not match.
  - Verify tip size in the boom is correct based on your desired spray speed, tip spacing, and target output.
  - Make sure all harness connectors on the back of the box, at the flow meter and at the flow regulator servo valve are secure.
  - Inspect drive-line speed sensor assembly, Remove any debris, especially metal shavings, from the red & black magnet assemblies on the drive-line (the metal particles can affect the pick-up sensors ability to read the signal, resulting with inaccurate speed readings and/or bad calibration settings by the computer).
  - Place control box power switch to the "manual" position. Push the master power toggle to the "ON" position, check the switches one-at-a-time for boom 1, then boom 2, then boom 3, checking switches in both directions. Verify each blue striped valve works in both directions.
  - If the Raven system is equipped with the RADAR speed sensor, refer to the Raven Manual for check-list and test procedures.
5. Optional accessories that may be installed.

Proceed with the check list for each accessory that has been installed on the Spraytek. Refer to the accessory manuals for adjustment and set-up procedures.

## 7 SPRAYER OPERATION

---

### Electric Boom Lift

- Check both actuator mounting bolts for tightness and for wing down position parallel to ground position, adjust according to set-up instructions.
- Check control harness fuse (30 amp rating).
- Check control console toggle switch for play and proper operation.
- Check harness connectors at control box and at each actuator.

### Hose Reel

- Check supply hose, from pressure side of pump to the swivel inlet on reel drum, for cracks, kinks or leaks.
- Lubricate the reel swivel at the grease zerk (if equipped).
- Check reel to tank hardware for tightness and evidence of leaks. Gasket sealer and fender washers should be used if not present (refer to the mounting instructions that come with the accessory).
- If electric rewind option is used, check battery and harness connections (40 amp circuit breaker should also be installed).

### Foam Marker

- Inspect solution tank for leaks and cracks.
- Check cap assembly for cracks and leaks.
- Check fuse in control harness (10 amp rating)
- Be sure to use only SDI Foam Concentrate with the foam marker accessory. Use of other brands will cause adverse performance.
- Activate power switch to the left then to the right positions and verify corresponding solenoid operation (you will hear a click) the compressor will start and if there is fluid in the container, liquid should flow to the feed tube on corresponding solenoid and foam generator cone junction tube.
- If solenoid clicks but foam liquid doesn't move through foam generator cone feed tubes, check each feed line check valve located just before each solenoid inlet. Clean as needed.
- Check supply fasteners on boom tubes for proper tightness and position. They should be positioned so they do not interfere with the tips or nozzle check valves. The loom (black ribbed cover) should run along the top of the boom tube and fastened with nylon cable ties.
- Check foam generator cone position. It should be at the end of the boom wing and clear the spray pattern distribution area. Keep cones out of spray by tilting up (required for rainbow style tips).

## 7.5 SPRAYER TANK ADDITIVES

---

**Dye Markers** - Avoid heavy, thick dye markers and only add dyes into a full mixing tank, Do not add to an empty tank.

Due to pigment granules and/or by-products, the use of dyes can lead to mechanical seal problems. Because of the high speed of the impeller seal and the heat that is generated, the pigments can scale up the ceramic seal surface. This will cause the seals to leak (pump appears broken). Frequent rinsing between smaller tank loads (batches) can reduce the leakage at the seals. Also, using less dye than recommended, but enough to still see a color (marker) change, can result in better performance.

**Spray Liquid Viscosity** - the addition of certain WP (Wettable Powders), WDG (Water Dispersers Granular) or EC (Emulsified Concentrate) chemicals, etc. may cause the viscosity (thickness) of the water to increase. This can sometimes affect the calibration of the spray nozzle out-put at pre-calibration water numbers. Consult Chemical Supplier for recommended modifications to your system.

## 7.6 CALIBRATION

Practice with water - after you have followed all recommendations, it is advisable to familiarize yourself with the operation of the dedicated sprayer and sprayer package. Practicing with plain water before the addition of expensive and potentially destructive chemical formulas (when mis-applied), can be smart and cost effective.

To spray and spray accurately, you must have a set standards to spray by.

The easiest method of calibration is to use as many fixed constants that can be controlled, and then modify the tip size & out-put pressure to lock in your desired application rate.

When using the following formulas, the application rate can be maintained by fixing the constants for each category.

To properly calibrate the sprayer, the following information is required.

**Desired Application Rate** - GPA (Gallons Per Acre) or G/1000 ft<sup>2</sup> (Gallons per 1000 square feet)

**Nozzle Spacing** - Distance in inches between spray tips

**Desired Ground Speed** - A fixed, ground speed is recommended to maintain accurate calibration

**Tip Style** - Type of pattern for particle distribution of applicable chemical to be applied, i.e. (FL, XR, TT).

**Tip Size** - Determines volume per minute, per nozzle and desired droplet (micron) size of spray carrier particles.

The following Formulas and conversion factors will help you obtain the necessary information.

### Abbreviations:

km - kilometer

m - meter

G - Gallon

l - Liter

GPA - Gallons per Acre

GPM - Gallons per Minute

MPH - Miles per hour

PSI - Pounds per square inch

W - Nozzle spacing in inches

### Conversion Factors:

One Acre = 43,560 ft<sup>2</sup> = 43.56 1000 ft<sup>2</sup> = 0.405 hectares

One Hectare = 2.471 Acres

One GPA = 2.9 Fluid Ounces/1000 ft<sup>2</sup> = 9.35 l/hectares

One G/1000 ft<sup>2</sup> = 43.56 GPA

One Gallon = 4 Quarts = 8 Pints = 128 fluid ounces

One Gallon = 3.79 l = 0.83 Imperial Gallons

One Mile = 5,280 ft = 1.61 km = 1610 m

One PSI = 0.069 bar = 6.896 kilopascal

### Fomulas:

GPM (per nozzle) = (GPA x MPH x W) / 5,940

GPM (per nozzle) = (G/1000 ft<sup>2</sup> x MPH x W) / 136

GPA = (5,490 x GPM (per nozzle)) / (mph x W)

G/1000 ft<sup>2</sup> = (136 x GPM (per nozzle)) / (mph x W)

# 7 SPRAYER OPERATION

## 7.7 MEASURING GROUND SPEED

The Spraytek offers four forward speeds, plus a high-low differential range. This gives you the option of eight (8) possible speeds. All spraying operations should be performed with the differential set in the low speed.

The spray pump is designed to run with an engine speed of 3,000 to 3,200 rpm. The ground control decal indicates the speed the vehicle should travel at different engine rpm settings.





 KPH				 KPH				 RPM	 MPH				 MPH			
1	2	3	4	1	2	3	4		1	2	3	4	1	2	3	4
1.1	2.0	2.7	4.0	3.5	6.5	8.9	12.6	1600	0.7	1.3	1.7	2.5	2.2	4.1	5.6	7.9
1.2	2.3	3.1	4.5	3.9	7.3	10.1	14.2	1800	0.8	1.4	2.0	2.7	2.4	4.6	6.2	8.9
1.3	2.5	3.5	4.9	4.3	8.2	11.2	15.8	2000	0.9	1.6	2.2	3.1	2.7	5.0	6.9	9.8
1.5	2.7	3.8	5.5	4.8	9.0	12.3	17.4	2200	0.9	1.7	2.4	3.4	3.0	5.6	7.6	10.8
1.6	3.1	4.2	6.0	5.2	9.7	13.4	18.9	2400	1.0	1.9	2.6	3.7	3.2	6.0	8.3	11.8
1.7	3.3	4.6	6.4	5.7	10.6	14.5	20.6	2600	1.1	2.0	2.8	4.0	3.5	6.6	9.0	12.8
1.9	3.5	4.9	7.0	6.0	11.4	15.6	22.1	2800	1.2	2.2	3.1	4.3	3.8	7.1	9.7	13.7
2.0	3.8	5.2	7.5	6.5	12.2	16.7	23.7	3000	1.3	2.4	3.2	4.6	4.1	7.6	10.4	14.8
2.1	4.0	5.6	7.9	7.0	13.0	17.8	25.3	3200	1.3	2.5	3.5	4.9	4.3	8.1	11.1	15.7

Figure 7C

It is recommended you establish ground speed based on the following information:

Measure a test course in the area to be sprayed or in an area with similar surface conditions (terrain) of the area to be sprayed.

A minimum length of 100 ft. (30.5 M) to test speeds up to 5 mph (8 km/h) is recommended.

A minimum length of 200 ft (61 M) to test speeds from 5 mph (8 km/h) up to 10 mph (16 km/h) is recommended.

To help ensure accuracy, conduct the speed check with the sprayer tank half-full and select the throttle setting and forward gear that will be used when spraying.

Determine the time required to travel the test course and run the course several times using the average time of all runs.

Use the following equation or the table shown to determine ground speed.

$$\text{speed (MPH)} = (\text{Distance ft} \times 60) / (\text{Time (Seconds)} \times 88)$$

Speed in MPH (km/h)	Time in Seconds		
	100 ft (30.5 m)	200 ft (61 m)	300 ft (91.4 m)
0.5 (0.8)	136	272	409
1.0 (1.6)	68	136	205
1.5 (2.4)	46	92	136
2 (3.2)	34	68	103
2.5 (4.0)	27	54	82
3.0 (4.8)	23	46	68
3.5 (5.6)	20	40	58
4.0 (6.4)	17	34	52
4.5 (7.2)	15	30	45
5.0 (8.0)	13	28	41

## 7.8 NOZZLE TIP SIZE

Tip size selected for use in your sprayer will depend on the desired GPM rate per nozzle, ground speed, nozzle spacing and spray pressure. The following chart will help in determining tip size, etc. when using the formulas mentioned on the previous page. The chart was taken from Page 10 of TeeJet Catalog 49A. For a complete listing of tip options and charts, call SDI or your local dealer for a new TeeJet Catalog.

$$\text{GPM (per nozzle)} = (1 \times 2.9 \times 20) / 136 = 29 / 136$$

$$\text{GPM (per nozzle)} = 0.426$$

If we take the answer (0.213) and look at the chart on the next page, we see a brown XR tip at 30 psi (206 kPa) or a gray XR tip at a 20 psi (138 kPa) will apply the proper amount based on Rate/Speed & Spacing constants used in the formula.

### An example of using the chart and formula:

Fixed Constants:

$$G/1000 \text{ ft}^2 = 1$$

$$\text{MPH} = 2.9$$

$$W = 20 \text{ inch Nozzle Spacing}$$

$$\text{GPM (per nozzle)} = (G/1000 \text{ ft}^2 \times \text{MPH} \times W) / 136$$

# SPRAYER OPERATION 7

Tip Color	Tip No. (Strainer Screen)		Liquid Pressure in PSI	Capacity 1 Nozzle in GPM	Capacity 1 Nozzle in oz/min	20" Nozzle Spacing							
	80° Series	110° Series				Gallons Per Acres				Gallons Per 1000 Square Feet			
						2 mph	3 mph	4 mph	5 mph	2 mph	3 mph	4 mph	5 mph
Orange	XR8001 (100 Mesh)	XR11001 (100 Mesh)	15	0.061	7.8	8.9	5.9	4.5	3.6	0.21	0.14	0.10	0.08
			20	0.071	9.1	10.4	6.9	5.3	4.2	0.24	0.16	0.12	0.10
			30	0.087	11	13.4	8.9	6.5	5.2	0.30	0.20	0.15	0.12
			40	0.10	13	14.9	9.9	7.4	5.9	0.34	0.23	0.17	0.14
			50	0.11	14	16.4	10.8	8.2	6.5	0.37	0.25	0.19	0.15
60	0.12	15	17.8	11.9	8.9	7.1	0.41	0.27	0.20	0.16			
Green	XR80015 (100 Mesh)	XR110015 (100 Mesh)	15	0.92	12	13.4	8.9	6.8	5.5	0.31	0.21	0.16	0.13
			20	0.11	14	16.3	10.9	8.2	6.5	0.37	0.25	0.19	0.15
			30	0.13	17	19.3	12.9	9.7	7.7	0.44	0.29	0.22	0.18
			40	0.15	19	22.0	14.9	11.1	8.9	0.51	0.34	0.26	0.20
			50	0.17	22	25.2	16.8	12.6	10.1	0.58	0.39	0.29	0.23
60	0.18	23	27.0	17.8	13.4	10.7	0.61	0.41	0.31	0.24			
Yellow	XR8002 (50 Mesh)	XR11002 (50 Mesh)	15	0.12	15	17.8	11.9	8.9	7.1	0.41	0.27	0.20	0.16
			20	0.14	18	21	13.9	10.4	8.3	0.48	0.32	0.24	0.19
			30	0.17	22	25	16.8	12.6	10.1	0.58	0.39	0.29	0.23
			40	0.20	26	30	19.8	14.9	11.9	0.68	0.45	0.34	0.27
			50	0.22	28	33	22	16.3	13.1	0.75	0.50	0.37	0.30
60	0.24	31	36	24	17.8	14.3	0.82	0.54	0.41	0.33			
Purple		XR110025 (50 Mesh)	15	0.15	19	22	14.8	11.1	8.9	0.51	0.34	0.26	0.20
	20		0.18	23	27	17.9	13.4	10.7	0.61	0.41	0.31	0.24	
	30		0.22	28	33	22	16.3	13.1	0.75	0.50	0.37	0.30	
	40		0.25	32	38	25	18.6	14.9	0.85	0.57	0.43	0.34	
	50		0.28	36	42	28	21	16.6	0.95	0.63	0.48	0.38	
60	0.31	40	46	31	23	18.4	1.1	0.70	0.53	0.42			
Blue	XR8003 (50 Mesh)	XR11003 (50 Mesh)	15	0.18	23	27	17.8	13.4	10.7	0.61	0.41	0.31	0.24
			20	0.21	27	31	21	15.6	12.5	0.61	0.48	0.36	0.29
			30	0.26	33	39	26	19.3	15.4	0.88	0.59	0.44	0.35
			40	0.30	38	45	30	22	17.8	1.0	0.68	0.51	0.41
			50	0.34	44	50	34	25	20	1.2	0.77	0.58	0.46
60	0.37	47	55	37	27	22	1.3	0.84	0.63	0.50			
Red	XR8004 (50 Mesh)	XR11004 (50 Mesh)	15	0.24	31	36	24	17.8	14.3	0.82	0.54	0.41	0.33
			20	0.28	36	42	28	21	16.6	1.0	0.63	0.48	0.38
			30	0.35	45	52	35	26	21	1.2	0.79	0.60	0.48
			40	0.40	51	59	40	30	24	1.4	0.91	0.68	0.54
			50	0.45	58	66	44	33	27	1.5	1.0	0.77	0.61
60	0.49	63	73	49	36	29	1.7	1.1	0.83	0.67			
Brown	XR8005 (50 Mesh)	XR11005 (50 Mesh)	15	0.31	40	46	30	23	18.4	1.1	0.70	0.53	0.42
			20	0.35	45	52	34	26	21	1.2	0.79	0.60	0.48
			30	<b>0.43</b>	55	64	42	32	26	1.5	0.97	0.73	0.58
			40	0.50	64	74	50	37	30	1.7	1.1	0.85	0.68
			50	0.56	72	84	56	42	33	1.9	1.3	0.95	0.76
60	0.61	78	90	60	45	36	2.1	1.4	1.0	0.83			
Grey	XR8006 (50 Mesh)	XR11006 (50 Mesh)	15	0.37	47	54	36	27	22	1.3	0.84	0.63	0.50
			20	<b>0.42</b>	54	62	42	31	25	1.4	1.0	0.71	0.57
			30	0.52	67	78	52	39	31	1.8	1.2	0.88	0.71
			40	0.60	77	90	60	45	36	2.0	1.4	1.0	0.82
			50	0.67	86	100	66	50	40	2.3	1.5	1.1	0.91
60	0.73	93	108	72	54	43	2.5	1.7	1.2	0.99			
White	XR8008 (50 Mesh)	XR11008 (50 Mesh)	15	0.49	63	72	48	36	29	1.7	1.1	0.83	0.67
			20	0.57	73	84	56	42	34	1.9	1.3	0.97	0.78
			30	0.69	88	102	68	51	41	2.3	1.6	1.2	0.94
			40	0.80	102	118	80	59	48	2.7	1.8	1.4	1.1
			50	0.89	114	132	88	66	53	3.0	2.0	1.5	1.2
60	0.98	125	146	99	73	58	3.3	2.2	1.7	1.3			

## 7 SPRAYER OPERATION

### 7.9 DETERMINING AMOUNT OF CHEMICALS REQUIRED

To determine the amount of chemicals to add to the spray tank, you need to know:

- The recommended application rate of the chemical. This information is given on the chemical label. The rate will be listed as pounds per acre (or pounds of active ingredient) for wettable powders and pints, quarts, or gallons per acre for liquids.
- The capacity of the tank. The Spraytek is equipped with a 300 gallon spray tank.
- The calibrated output of the sprayer.

#### Example 1, Dry Formulation:

A carbaryl recommendation calls for 2 pounds of active ingredient (a.i.) per acre. You have purchased Sevin (80-percent wettable powder). Your sprayer has a 300 gallon tank and is calibrated to apply 20 gallons per acre. How much Sevin should be added to the spray tank?

1. Determine the number of acres you can spray with each tankful
  - Tank Capacity / Spray Rate =  $300 / 20 = 15$  Acres
2. Determine the pounds of pesticide product needed per acre. Because only 80% of the Sevin in the bag is an active ingredient, you will have to add more than two pounds of the product to each "acre's worth" of water in your tank.

Divide the percentage of active ingredient (80%) into the total (100%).

- $100 / 80 = 1.25$

Multiply the result times the application rate.

- $2 \text{ lb/acre} \times 1.25 = 2.5 \text{ lb. Sevin per acre}$

3. Determine the amount of pesticide to add to each tankful. With each tankful you will cover 15 acres (Step 1), and you want 2.5 lbs. of product per acre (Step 2).
  - $15 \text{ acres} \times 2.5 \text{ lb. sevin per acre} = 37.5 \text{ lb.}$

To apply the recommended application rate, you will need to add 37.5 lb. of Sevin for each full 300 gallon tankful.

#### Example 2, Liquid Formulation:

A trichlorfon recommendation calls for 1 pound of active ingredient (a.i.) per acre. You have purchased Dylox 4E (4 pounds per gallon formulation). Your sprayer has a 300 gallon tank and is calibrated at 15 gallons per acre. How much Dylox should you add to the spray tank?

1. Determine the number of acres you can spray with each tankful
  - Tank Capacity / Spray Rate =  $300 / 15 = 20$  Acres
2. Determine the amount of product needed per acre.

Divide the percentage of active ingredient (1 lb) into the concentration of the formula (4 lb / Gallon).

- $1 \text{ lb} / 4 \text{ lb per gallon} = 0.25 \text{ Gallon per acre}$

3. Determine the amount of pesticide to add to each tankful. With each tankful you will cover 20 acres (Step 1), and you want 0.25 Gallons of product per acre (Step 2).

- $20 \text{ acres} \times 0.25 \text{ Gallon Dylox per acre} = 5 \text{ Gallons}$

To apply the recommended application rate, you will need to add 5 Gallons of Dylox for each full 300 gallon tankful.

#### Adjuvants:

The chemical manufacturer may recommend that you add a small amount of an adjuvant (spreader-sticker, surfactant, etc.) in addition to the regular chemical. This recommendation is often given as "percent concentration."

If you use an adjuvant at a 1/2% concentration by volume, how much should you add to a 300 gallon tank.

Convert percentage into decimal form

- $1/2\% = 0.005$

Multiply tank capacity by decimal amount of adjuvant

- $300 \text{ Gallons} \times 0.005 = 1.5 \text{ Gallons adjuvant}$

## 7.10 ADDING WATER TO TANK.

1. Park Vehicle on level ground, turn off engine, place gear selector into neutral and apply the park brake.

**⚠ CAUTION**

Use care when opening sprayer tank lid. Potentially dangerous chemical fumes may have accumulated inside tank.

2. Remove the lid from the top of the spray tank by turning counter-clockwise (if unit is equipped with an anti-siphon device for back-flow protection, rotate and lock the goose neck filler into position).
3. Keep the strainer basket in place, attach the feeder hose to the goose neck filler or place hose end into tank opening to begin filling. Slowly, turn the water source on gradually bringing it up to full stream (avoid splashing). The basket strainer should always be left in place when adding any material to the tank.
4. Determine amount of spray mix to be used for your application. If the required amount is less than full tank capacity, fill to desired level. If the required amount is a full load, only fill tank to 3/4 full (this will leave room for adding the chemicals which will be mixed, the balance of the fill water will be added later).
5. If the pump suction strainer (filter) is not installed, do so at this time and open the suction gate-valve to the pump.
6. Start the engine and using the governor hand control, set the engine rpm's to 3,000 rpm's.
7. Flip the pump switch to the ON" position. Look into the open lid (remove basket temporarily to look inside the tank). You should be able to see the water moving around from the force of the agitation jets etc. (the agitation handle should be in the fully open position).
8. If there is no water movement from the jets or from the sump area, stop the engine and check the trouble-shooting guidelines for possible causes.
9. Once the system is operational, a quick test should be performed before adding any product to the tank.
  - a. Lower the boom wings to their operating position. Turn on the Master Boom Control and adjust pressure to 40 PSI (276 kPa) on the controller gauge.

- b. All nozzles should come on and develop a full pattern. Check boom, hoses and nozzles for leaks and faulty patterns. Repair and/or clean any items which may require attention.
- c. If all systems are operating properly, you may proceed to the loading and mixing area.

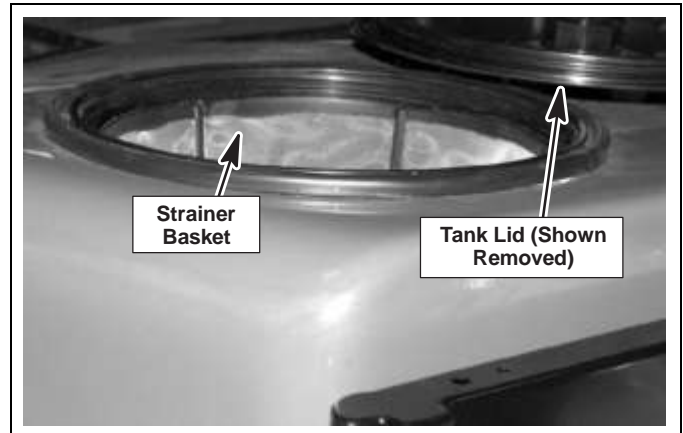

Figure 7D

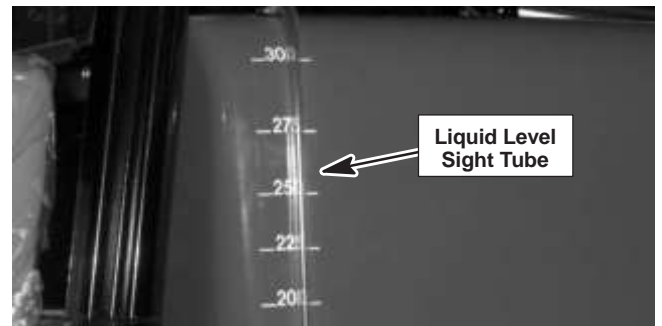

Figure 7E

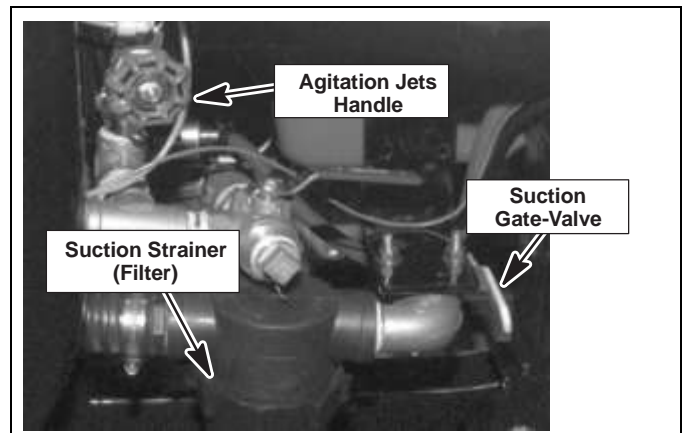

Figure 7F

## 7 SPRAYER OPERATION

### 7.11 MIXING CHEMICALS



#### WARNING

Special safety equipment may be required to prevent accidental exposure to poisoning and should be worn at all times when working with chemicals.

Contact your chemical supplier for proper material handling. Always refer to the chemical manufacturers MSDS (Material Safety Data Sheet), that is available for all chemicals. **Special attention should be given to required safety equipment, first aid treatment for accidental inhalation, swallowing, absorption or injection and compatibility with other chemicals.**

Never work with harmful chemicals alone. Always have a second person nearby in case of emergency.

Some chemicals may be flammable or produce flammable vapors.

- Do not smoke when handling or mixing chemicals.
- Never store chemicals near an open flame or spark which could ignite chemical or chemical vapors.

The mixing of non-compatible materials or formulations not previously tested by chemical professionals should be avoided. Volatile "brews" can be damaging and costly to repair and dispose of. Leave the burden of mix-up compatibility to the people who manufacture and sell the products to you.

Mis-use of chemicals is not a warrantable offense if sprayer damage occurs.

Mix times may vary by chemical, load size, water temperature and operator experience.

Normal mix time can be 20 to 30 minutes per tank. This allows enough time to provide complete particle distribution throughout the complete mixable liquid in the tank.

Just because the water is murky and clouded in the tank does not mean all the chemical is mixed.

**NOTE:** *System calibration and product active ingredient formula calibration should have already be completed. If not, refer to the appropriate sections and compute your application data before continuing.*

Slowly add (Spoon feed), the chemicals to be applied to the agitating tank water. The addition of some products, all-at-once, may cause damage to the centrifugal pumps internal mechanical seals. Wettable Powders (WP), Emulsified Concentrate (EC), Water Dispersed Granular (WDG) chemicals etc., are abrasive in nature and should include extra mix time in the tank. Pre-packaged dissolvable bag types are also difficult to mix rapidly. The slow dissolve of the wrapper may lead to clogged suction strainers under certain "hasty" conditions. Liquid products can mix easier than most dry formulations, but can be difficult to mix in cold water areas. Consult with your chemical supply representative for any precautions or mixing suggestions for any unfamiliar products.

**Give it some time!** Haste during the critical mixing phase, then spraying too soon, may cause severe damage to the turf because of rate changes from what your original rate was suppose to be.

- The first 1/3 of the tank could apply more than the desired rate when heavy products are not fully suspended in the carrier water.
- The second 1/3 of the tank could apply close to the correct rate.
- The final 1/3 of the tank would be light on active ingredients.

At the completion of the chemical mixing phase (allowing proper time for particle distribution) you are now ready to apply the chemical mix to your fine turf.

7.12 SPRAYER CLEANING

 **WARNING**

Sprayer cleaning solutions are chemicals and should be given the same attention as chemicals used during sprayer operation. Special safety equipment may be required to prevent accidental exposure to poisoning and should be worn at all times when working with chemicals.

Contact your chemical supplier for proper material handling. Always refer to the chemical manufacturers MSDS (Material Safety Data Sheet), that is available for all chemicals. **Special attention should be given to required safety equipment, first aid treatment for accidental inhalation, swallowing, absorption or injection and compatibility with other chemicals.**

Never work with harmful chemicals alone. Always have a second person nearby in case of emergency.

Some chemicals and cleaning solutions may be flammable or produce flammable vapors.

- Do not smoke when handling or mixing chemicals.
- Never store chemicals near an open flame or spark which could ignite chemical or chemical vapors.

After use, clean the sprayer thoroughly with a cleaning solution. During cleaning, always follow these guidelines.

1. Use care when opening sprayer tank cover. Potentially dangerous chemical fumes may have accumulated inside tank.
2. Type of cleaning solution required is determined by chemical used in sprayer. Refer to the chemical label for cleaning solution compatibility and specific cleaning instructions.
3. Sprayer cleaning should only be performed in an area with run-off recovery or containment. If one is not available, be certain the run-off does not contaminate water supplies, public sewers or natural wet land areas. Check your local regulations for requirements in your area.
4. Remove the nozzles from spray booms. Clean nozzle tips and screens in a strong detergent solution or kerosene using a soft bristled toothbrush.
5. Flush the sprayer system with clean water.
6. Add a mixture of 2 pounds (0.91 kg) of cleaning solution for each 30 to 40 gallons (114 to 152 l) of water. This should be sufficient for removing most pesticides.

7. Close hose reel and/or boom supply valves. Operate pump to allow cleaning solution to circulate through the system and agitate in the tank thoroughly. Open supply valves and allow detergent solution to flow through remainder of the system for several minutes.
8. Flush the system twice with clean water.
9. During the cleaning, examine the hoses, clamps, connections, no-drip valves, nozzle tips and screens. Replace any components if damaged, leaking or not functioning properly.

**Special Cleaning Requirements:**

1. Some pesticide combinations (especially if oil is used) may produce a putty like paste inside the tank.
  - a. Flushing out residue of such chemicals after each load will help prevent accumulation.
  - b. If water alone does not remove the build up, add a solution equal to 1 gallon (3.8 l) or solvent (Stoddard solvent, kerosene or diesel fuel) per 25 gallons (95 l) or water. Allow the paste to dissolve then agitate and flush the system.
2. If phenoxy herbicides, such as 2,4-D, have been used in the system:
  - a. Rinse the tank with clean water.
  - b. Mix **one** of the following chemicals with 25 gallons (95 l) of clean water.
    - 1 Quart (0.95 l) household ammonia
    - 1 Pound (0.45 kg) of washing soda (sal soda)
    - 2 Pounds (0.91 kg) of trisodium phosphate
  - c. Rinse inside of tank with solution. Allow mixture to agitate in tank and let a small amount flow through the nozzles.
  - d. Keep remainder of mixture in the system overnight and pump it out in the morning.
  - e. Rinse and flush the system with clean water.





## **World Class Quality, Performance And Support**

Equipment from Jacobsen is built to exacting standards ensured by ISO 9001 and ISO 14001 registration at all of our manufacturing locations.

A worldwide dealer network and factory trained technicians backed by Textron Parts Xpress provide reliable, high-quality product support.



**JACOBSEN**  
A Textron Company

---

**BOBCAT BUNTON CUSHMAN EZGO JACOBSEN RANSOMES RYAN STEINER**

Textron Golf, Turf & Specialty Products  
PO Box 7708, Charlotte, NC 28241-7708  
[www.ttcsp.com](http://www.ttcsp.com)