

GO GO

ES 8



OWNER'S MANUAL

Pride[®]
Mobility Products Ltd.
www.pridemobility.com

32 Wedgwood Road Bicester, Oxon OX26 4UL

SAFETY GUIDELINES



WARNING! An authorised Pride Dealer or qualified technician must perform the initial setup of this Travel Scooter and must perform all of the procedures in this manual.

The symbols below are used throughout this owner's manual and on the scooter to identify warnings and important information. It is very important for you to read them and understand them completely.



WARNING! Indicates a potentially hazardous condition/situation. Failure to follow designated procedures can cause either personal injury, component damage or malfunction. On the product, this icon is represented as a black symbol on a yellow triangle with a black border.



MANDATORY! These actions should be performed as specified. Failure to perform mandatory actions can cause personal injury and/or equipment damage. On the product, this icon is represented as a white symbol on a blue dot with a white border.



PROHIBITED! These actions are prohibited. These actions should not be performed at any time or in any circumstances. Performing a prohibited action can cause personal injury and/or equipment damage. On the product, this icon is represented as a black symbol with a red circle and red slash.

Please fill out the following information for quick reference:

Pride Dealer: _____
Address: _____
Phone Number: _____
Purchase Date: _____ Serial Number: _____

NOTE: This owner's manual is compiled from the latest specifications and product information available at the time of publication. We reserve the right to make changes as they become necessary. Any changes to our products may cause slight variations between the illustrations and explanations in this manual and the product you have purchased. The latest/current version of this manual is available on our website.



CONTENTS

I. INTRODUCTION	4
II. SAFETY	5
III. YOUR TRAVEL SCOOTER	19
IV. BATTERIES AND CHARGING	24
V. OPERATION	29
VI. COMFORT ADJUSTMENTS	31
VII. DISASSEMBLY AND ASSEMBLY	33
VIII. BASIC TROUBLESHOOTING	35
IX. CARE AND MAINTENANCE	37
X. WARRANTY	40

I. INTRODUCTION

SAFETY

WELCOME to Pride Mobility Products (Pride). The product you have purchased combines state-of-the-art components with **safety**, comfort, and styling in mind. We are confident that these design features will provide you with the conveniences you expect during your daily activities. Understanding how to **safely** operate and care for this product should bring you years of trouble free operations and service.

Read and follow all instructions, warnings, and notes in this manual before attempting to operate your Travel Scooter for the first time. You must also read all instructions, warnings, and notes contained in any supplemental instructional booklets that accompanied your Travel Scooter before initial operation. Your **safety** depends upon you, as well as your provider, carer, or healthcare professional in using good judgement.

If there is any information in this manual which you do not understand, or if you require additional assistance for setup or operation, please contact your authorised Pride Dealer. **Failure to follow the instructions, warnings, and notes in this manual and those located on your Pride product can result in personal injury or product damage and will void Pride's product warranty.**

PURCHASER'S AGREEMENT

By accepting delivery of this product, you promise that you will not change, alter, or modify this product or remove or render inoperable or unsafe any guards, shields, or other safety features of this product; fail, refuse, or neglect to install any retrofit kits from time to time provided by Pride to enhance or preserve the safe use of this product.

SHIPPING AND DELIVERY

Before using your Travel Scooter, make sure your delivery is complete as some components may be individually packaged. If you do not receive a complete delivery, please contact your authorised Pride Dealer immediately. Where damage has occurred during transport, either to the packaging or content, please contact the delivery company responsible.

INFORMATION EXCHANGE

We want to hear your questions, comments, and suggestions about this manual. We would also like to hear about the safety and reliability of your new Travel Scooter, and about the service you received from your authorised Pride Dealer. Please notify us of any change of address, so we can keep you apprised of important information about safety, new products, and new options that can increase your ability to use and enjoy your Travel Scooter. Please feel free to contact us at the address below:

Pride Mobility Products Ltd.
32 Wedgwood Road
Bicester, Oxon OX26 4UL

NOTE: If you ever lose or misplace your product registration card or your copy of this manual, contact us and we will be glad to send you a new one immediately.

II. SAFETY

PRODUCT SAFETY SYMBOLS

The symbols below are used on the Travel Scooter to identify warnings, mandatory actions, and prohibited actions. It is very important for you to read and understand them completely.



Read and follow the information in the owner's manual.



Maximum seating weight.



Pinch/Crush points created during assembly.



Corrosive chemicals contained in battery.



EMI/RFI - This product has been tested and passed at an immunity level of 20 V/m.



Indicates electrical shock hazard.



Unlocked and in freewheel mode.

Do not place the Travel Scooter in freewheel mode when on an incline.

Place unit on level ground and stand to one side when changing from drive mode to freewheel mode or freewheel mode to drive mode.

Do not place the Travel Scooter in freewheel mode when on a decline.

Locked and in drive mode.

II. SAFETY



Do not allow unsupervised children to play near the Travel Scooter while the batteries are charging.



Do not remove anti-tip wheels.



Do not use a cell phone, walkie/talkie, laptop or other radio transmitter while operating.



Avoid exposure to rain, snow, ice, salt or standing water whenever possible. Maintain and store in a clean and dry condition.



Removal of grounding prong can create electrical hazard. If necessary, properly install an approved 3-pronged adapter to an electrical outlet having 2-pronged plug access.



Do not connect an extension lead to the AC/DC converter or the battery charger.



Keep tools and other metal objects away from battery terminals. Contact with tools can cause electrical shock.



Keep your hands away from the tyres when driving. Be aware that loose fitting clothing can become caught in the drive tyres.



Do not expose to heat sources such as open flame or sparks. Do not transport batteries with flammable or combustible items.

II. SAFETY



Do not mix AGM and Gel-Cell batteries. Always use batteries of the same type and chemistry.



Do not use batteries with different amp-hour (Ah) capacities. Do not mix old and new batteries. Always replace both batteries at the same time.



Use only AGM or Gel-Cell batteries to reduce the risk of leakage or explosive conditions.



Explosive conditions exist!



Disposal and recycling - Contact your authorised Pride Dealer for information on proper disposal of your Pride product and its packaging.



Battery posts, terminals and related accessories contain lead and lead compounds. Wear goggles and gloves when handling batteries and wash hands after handling.



Battery charger for indoor use only.



Fully charge batteries before operating.

Remove key from an unattended Travel Scooter.

II. SAFETY



Travel Scooter does not conform to ISO 7176-19 for transport of an occupied Travel Scooter in a motor vehicle.



Contains sealed, non-spillable batteries that meet DOT CRF 173.159 (d), IATA packing instructions 806, IATA provision A67 for safe transportation.



Keep area clean.

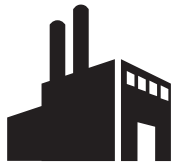

Manufactured in.



Keep area dry.



Indicates tie-down points on the scooter.

Model:	XXXXXX
Manufacturer:	Pride Mobility Products Corp. www.pridemobility.com
Maximum Speed:	XXX km/h (X.X mph)
Maximum User Weight:	XXX kg, (XXX lbs.)
Unit Weight (Unloaded):	XXX.XX kg, (XXX lbs.)
Maximum Angle Capacity:	XX.X° (XX°)
Maximum Allowable Incline:	XX.X% (X°)

ACN 088 609 661 CE CLASSE II

Travel Scooter information label.

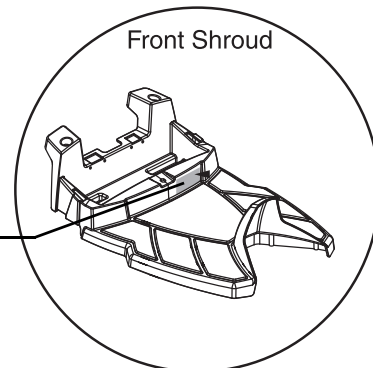

**RECOMMENDED
FOR 10-12Ah
BATTERIES** CE

Battery charger maximum amp-hour (Ah) charging information label.

II. SAFETY

GENERAL



MANDATORY! Do not operate your new Travel Scooter for the first time without completely reading and understanding this owner's manual.

Your Travel Scooter is a state-of-the-art life-enhancement device designed to increase mobility. Pride provides an extensive variety of products to best fit the individual needs of the Travel Scooter user. Please be aware that the final selection and purchasing decision regarding the type of Travel Scooter to be used is the responsibility of the Travel Scooter user who is capable of making such a decision and his/her healthcare professional (i.e., medical doctor, physical therapist, etc.).

The contents of this manual are based on the expectation that a mobility device expert has properly fitted the Travel Scooter to the user and has assisted the prescribing healthcare professional and/or the authorised Pride Dealer in the instruction process for the use of the product.

There are certain situations, including some medical conditions, where the Travel Scooter user will need to practice operating the Travel Scooter in the presence of a trained attendant. A trained attendant can be defined as a family member or care professional specially trained in assisting a Travel Scooter user in various daily living activities.

As you begin using your Travel Scooter during daily activities, you will probably encounter situations in which you will need some practice. Simply take your time and you will soon be in full and confident control as you maneuver through doorways, on and off lifts, up and down ramps and over moderate terrain.

Below are some precautions, tips and other safety considerations that will help you become accustomed to operating the Travel Scooter safely.

MODIFICATIONS

Pride has designed and engineered your Travel Scooter to provide maximum mobility and utility. A wide range of accessories is available from your authorised Pride Dealer to further customise your Travel Scooter to better suit your needs and/or preferences. However, under no circumstances should you modify, add, remove or disable any feature, part or function of your Travel Scooter.



WARNING! Do not modify your Travel Scooter in any way not authorised by Pride. Do not use accessories if they have not been tested or approved for Pride products.

REMOVABLE PARTS



WARNING! Do not attempt to lift or move your Travel Scooter by any of its removable parts, including the armrests, seat or shroud. Pride recommends use of only solid, non-removable frame components such as Travel Scooter securement points or the front and rear frame weldments to lift or move your Travel Scooter.

WARNING! Lifting the Travel Scooter should be accomplished with no fewer than three people, one at the front and two at the rear of the unit.

PRE-RIDE SAFETY CHECK

Get to know the feel of your Travel Scooter and its capabilities. Pride recommends that you perform a safety check before each use to make sure your Travel Scooter operates smoothly and safely.

II. SAFETY

Perform the following inspections prior to using your Travel Scooter:

- Check for proper tyre inflation. Maintain but do not exceed the psi/bar/kPa air pressure rating indicated on each tyre if equipped with pneumatic tyres.
- Check all electrical connections. Make sure they are tight and not corroded.
- Check all harness connections. Make sure they are secured properly.
- Check the brakes.
- Check battery charge.

If you discover a problem, contact your authorised Pride Dealer for assistance.

TYRE INFLATION

If your Travel Scooter is equipped with pneumatic tyres, you should check or have the air pressure checked at least once a week. Proper inflation pressures will prolong the life of your tyres and help ensure the smooth operation of your Travel Scooter.



WARNING! It is critically important that the psi/bar/kPa air pressure indicated on each tyre be maintained in pneumatic tyres at all times. Do not underinflate or overinflate your tyres. Low pressure may result in loss of control, and overinflated tyres may burst. Failure to maintain the psi/bar/kPa air pressure rating indicated on pneumatic tyres at all times may result in tyre and/or wheel failure.

WARNING! Inflate your Travel Scooter tyres from a regulated air source with an available pressure gauge. Inflating your tyres from an unregulated air source could overinflate them, resulting in a burst tyre.

NOTE: If tyres on your Travel Scooter list the psi rating only, use the following conversion formulas to find the bar or kPa rating: $bar = psi \times 0.06895$; $kPa = psi \times 6.89476$.

WEIGHT LIMITATIONS

Your Travel Scooter is rated for a maximum weight capacity. Refer to the specifications table for information. Keep in mind that the maximum weight capacity includes the combined weight of the user and any accessories mounted to the Travel Scooter.



MANDATORY! Stay within the specified weight capacity for your Travel Scooter. Exceeding the weight capacity voids your warranty. Pride will not be held responsible for injuries and/or property damage resulting from failure to observe weight limitations.



WARNING! Do not carry passengers on your Travel Scooter. Carrying passengers on your Travel Scooter may affect the centre of gravity, resulting in a tip or a fall.

INCLINE INFORMATION

More and more buildings have ramps with specified degrees of inclination, designed for easy and safe access. Some ramps may have turning switchbacks (180-degree turns) that require you to have good cornering skills on your Travel Scooter.

- Proceed with extreme caution as you approach the downgrade of a ramp or other incline.
- Take wide swings with your Travel Scooter around any tight corners. If you do that, the Travel Scooter's rear wheels will follow a wide arc, not cut the corner short and not bump into or get hung up on any railing corners.
- When driving down a ramp, keep the Travel Scooter's speed adjustment set to the slowest speed setting to ensure a safely controlled descent.
- Avoid sudden stops and starts.

II. SAFETY

When climbing an incline, try to keep your Travel Scooter moving. If you must stop, start up again slowly, and then accelerate cautiously. When driving down an incline, do so by setting the speed adjustment dial to the slowest setting and driving in the forward direction only. If your Travel Scooter starts to move down the incline faster than you anticipated or desired, allow it to come to a complete stop by releasing the throttle control lever. Then push the throttle control lever forward slightly to ensure a safely controlled descent.



WARNING! When on any sort of an incline or decline, never place the Travel Scooter in freewheel mode while seated on it or standing next to it.

WARNING! When climbing an incline, do not zigzag or drive at an angle up the face of the incline. Drive your Travel Scooter straight up the incline. This greatly reduces the possibility of a tip or a fall. Always exercise extreme caution when negotiating an incline.



WARNING! Do not drive your Travel Scooter across the side of an incline or diagonally up or down an incline; do not stop, if possible, while driving up or down an incline.

WARNING! You should not travel up or down a potentially hazardous incline (i.e., areas covered with snow, ice, cut grass, or wet leaves).

WARNING! Even though your Travel Scooter is capable of climbing slopes greater than those illustrated in figure 1, do not, under any circumstances, exceed the incline guidelines or any other specifications presented in this manual. Doing so could cause instability in your Travel Scooter.

Handicap public access ramps are not subject to government regulation in all countries, and therefore do not necessarily share the same standard percent of slope. Other inclines may be natural or, if man-made, not designed specifically for Travel Scooters. **Figure 1** illustrates your Travel Scooter's stability and its ability to climb grades under various weight loads and under controlled testing conditions.

These tests were conducted with the Travel Scooter's seat in the highest position and adjusted rearward on the seat base to its farthest rearward position. Use this information as a guideline. Your Travel Scooter's ability to travel up inclines is affected by your weight, your Travel Scooter's speed, your angle of approach to the incline and your Travel Scooter setup.

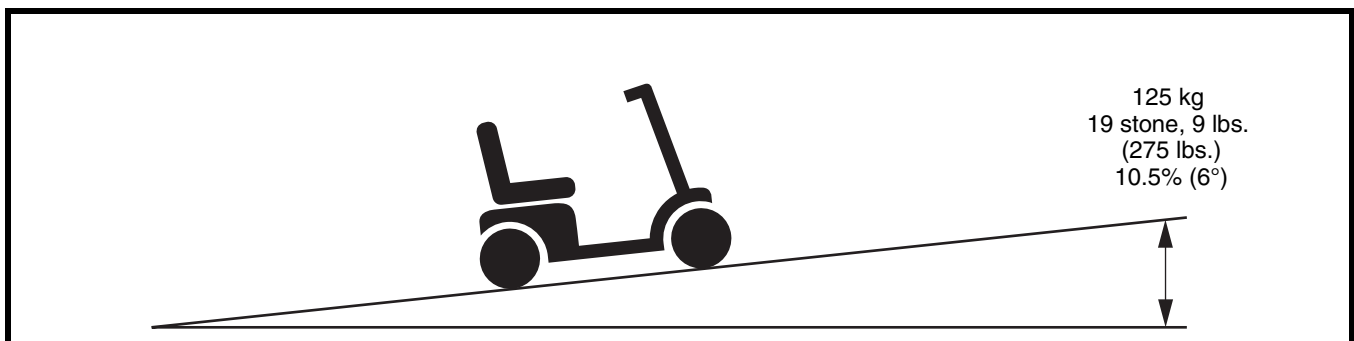

Figure 1. Maximum Recommended Incline Angle



WARNING! Any attempt to climb or descend a slope steeper than what is shown in figure 1 may put your Travel Scooter in an unstable position and cause it to tip.

WARNING! Never carry an oxygen tank weighing more than 6 kg (13 lbs.). Never fill the front or rear basket with contents exceeding 6 kg (13 lbs.).

II. SAFETY

When you approach an incline, it is best to lean forward. See **figures 2 and 2A**. This shifts the centre of gravity of you and your Travel Scooter toward the front of the Travel Scooter for improved stability.

NOTE: When negotiating ramps, if the throttle control lever is released while moving forward, the powered Travel Scooter may "roll back" approximately 30.5 cm (1 foot) before the brake engages. If the throttle control lever is released while moving in reverse, the powered Travel Scooter may "roll back" approximately 1 metre (3 feet) before the brake engages.



Figure 2. Normal Driving Position



Figure 2A. Increased Stability Driving Position

CORNERING INFORMATION

Excessively high cornering speeds can create the possibility of tipping. Factors which affect the possibility of tipping include, but are not limited to, cornering speed, steering angle (how sharply you are turning), uneven road surfaces, inclined road surfaces, riding from an area of low traction to an area of high traction (such as passing from a grassy area to a paved area – especially at high speed while turning) and abrupt directional changes. High cornering speeds are not recommended. If you feel that you may tip over in a corner, reduce your speed and steering angle (i.e., lessen the sharpness of the turn) to prevent your Travel Scooter from tipping.



WARNING! When cornering sharply, reduce your speed and maintain a stable centre of gravity. When using your Travel Scooter at higher speeds, do not corner sharply. This greatly reduces the possibility of a tip or fall.

BRAKING INFORMATION

Your Travel Scooter is equipped with these powerful brake systems:

- Regenerative: Uses electricity to rapidly slow the vehicle when the throttle control lever returns to the centre/stop position.
- Disc Park Brake: Activates mechanically after regenerative braking slows the vehicle to near stop, or when power is removed from the system for any reason.

II. SAFETY

OUTDOOR DRIVING SURFACES

Your Travel Scooter is designed to provide optimum stability under normal driving conditions—dry, level surfaces composed of concrete, blacktop or tarmac. However, Pride recognises that there will be times when you will encounter other surface types. For this reason, your Travel Scooter is designed to perform admirably on packed soil, grass, and gravel. Feel free to use your Travel Scooter safely on lawns and in park areas.

- Avoid driving on uneven terrain and/or soft surfaces.
- Avoid tall grass that can become tangled in the running gear.
- Avoid loosely packed gravel and sand.
- Do not use your Travel Scooter in fresh or salt water.
- Do not use your Travel Scooter at the edge of a stream, lake or ocean.
- If you feel unsure about a driving surface, avoid that surface.

PUBLIC STREETS AND ROADWAYS



WARNING! Exercise extreme caution when operating the scooter on footpaths, pavements, bridleways, pedestrian areas and roads. Obey all local pedestrian traffic rules.

STATIONARY OBSTACLES (STEPS, KERBS, ETC.)

WARNING! Do not drive near raised surfaces, unprotected ledges and/or drop-offs (kerbs, porches, stairs, etc.).

WARNING! Do not attempt to have your Travel Scooter climb or descend an obstacle that is inordinately high.



WARNING! Do not attempt to have your Travel Scooter proceed rearward down any step, kerb or other obstacle. This may cause the Travel Scooter to tip.

WARNING! Be sure your Travel Scooter is traveling perpendicular to any kerb you may be required to ascend or descend. See figures 3 and 3A.

WARNING! Even though your Travel Scooter may be capable of handling greater obstacles, Pride recommends that you do not attempt to negotiate a kerb that has a height greater than 5 cm (2 in.). Doing so could cause instability in your Travel Scooter.

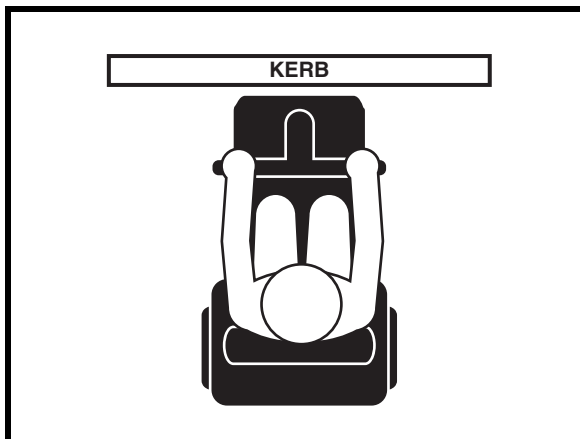

Figure 3. Correct Kerb Approach



Figure 3A. Incorrect Kerb Approach

II. SAFETY

INCLEMENT WEATHER PRECAUTIONS

Exposure of your Travel Scooter to inclement weather conditions should be avoided whenever possible. If suddenly caught up in rain, snow, severe cold or heat while operating your Travel Scooter, proceed to shelter at the earliest opportunity. Thoroughly dry your Travel Scooter before storing, charging or operating your Travel Scooter.



PROHIBITED! Operating in rain, snow, salt, mist/spray conditions and on icy/slippery surfaces can cause damage to the scooter and electrical system. Maintain and store your Travel Scooter in a dry and clean condition.



WARNING! Prolonged exposure to hot or cold conditions may affect the temperature of upholstered and non-upholstered items on the Travel Scooter, possibly resulting in skin irritation. Exercise caution when using your Travel Scooter in extremely hot or cold conditions or when exposing your Travel Scooter to direct sunlight for prolonged periods of time.

FREEWHEEL MODE

Your Travel Scooter is equipped with a manual freewheel lever that, when pushed forward, allows the Travel Scooter to be pushed. For more information about how to place your Travel Scooter into and out of freewheel mode, see III. “Your Travel Scooter.”



WARNING! When your Travel Scooter is in freewheel mode, the braking system is disengaged.

- Disengage the drive motors only on a level surface.
- Ensure the key is removed from the key switch.
- Stand to the side the Travel Scooter to engage or disengage freewheel mode. Never sit on a Travel Scooter to do this.
- After you have finished pushing your Travel Scooter, always return it to the drive mode to lock the brakes.

An added feature built into the Travel Scooter is “push-too-fast” protection which safeguards the Travel Scooter against gaining excessive speed while in freewheel mode.

“Push-too-fast” operates differently depending on which of two conditions exists:

- If the key is switched “off” while in freewheel mode, the Travel Scooter’s controller activates regenerative braking when the Travel Scooter is pushed faster than a maximum threshold which has been preprogrammed. In this case, the controller is acting as a speed governor.
- If the key is switched “on” while in freewheel mode, you will encounter considerable resistance at any speed. This prevents the Travel Scooter from gaining unwanted momentum should the manual freewheel lever inadvertently be released while driving the Travel Scooter.



WARNING! Pride recommends that you do not disconnect the batteries when the Travel Scooter is in freewheel mode as this may interfere with the function of the controller.

STAIRS AND ESCALATORS

Travel Scooters are not designed to travel up or down stairs or escalators. Always use an lift.



WARNING! Do not use your Travel Scooter to negotiate steps or escalators.

DOORS

- Determine if the door opens toward or away from you.
- Use your hand to turn the knob or push the handle or push-bar.
- Drive your Travel Scooter gently and slowly forward to push the door open. Or drive your Travel Scooter gently and slowly rearwards to pull the door open.

II. SAFETY

LIFTS

Modern lifts have a door edge safety mechanism that, when pushed, reopens the door(s).

- If you are in the doorway of a lift when the door(s) begin to close, push on the rubber door edge or allow the rubber door edge to contact the Travel Scooter and the door will reopen.
- Use care that handbags, packages or Travel Scooter accessories do not become caught in lift doors.

NOTE: *If your Travel Scooter's turning radius is greater than 152.4 cm (60 in.), it may be difficult to maneuver in lifts and building entrances. Use caution when attempting to turn or maneuver your Travel Scooter in small spaces and avoid areas that might pose a problem.*

LIFT SYSTEMS/ELEVATION PRODUCTS

If you will be transporting your Travel Scooter during travel, you may find it necessary to use a vehicle-mounted lift system or elevation product to aid in transportation. Pride recommends that you closely review the warnings, instructions, specifications and safety information set forth by the manufacturer of the lift/elevation product before using that product.



WARNING! Not all lift systems/elevation products are rated for use with an occupied mobility device. Pride recommends that you do not remain seated in your Travel Scooter when it is being used in connection with any type of lift system/elevation product unless:

- That product is rated for occupied use by the manufacturer.
- You are able to occupy your mobility device in strict conformity with the warnings, instructions, specifications and safety guidelines set forth by the manufacturer.

WARNING! Always turn off the power to the Travel Scooter when you are being transferred via an elevation product. Failure to do so may result in accidental throttle control lever contact, resulting in unintended movement and personal injury or product damage.

BATTERIES

In addition to following the warnings below, be sure to comply with all other battery handling information.



MANDATORY! Battery posts, terminals, and related accessories contain lead and lead compounds. Wear goggles and gloves when handling batteries and wash hands after handling.

WARNING! Travel Scooter batteries are heavy. See specifications table. If you are unable to lift that much weight, be sure to get help. Use proper lifting techniques and avoid lifting beyond your capacity.



WARNING! Always protect the batteries from freezing and never charge a frozen battery. Charging a frozen battery may result in damage to the battery.

WARNING! Connect the battery harnesses in the proper manner. RED (+) cables must be connected to positive (+) battery terminals/posts. BLACK (-) cables must be connected to negative (-) battery terminals/posts. Protective caps should be installed over all battery terminals. REPLACE cables immediately if damaged.

BATTERIES AND RECYCLING

If you encounter a damaged or cracked battery, immediately enclose it in a plastic bag. Contact your local waste disposal agency or authorised Pride Dealer for instructions on disposal and battery recycling, which is our recommended course of action.

II. SAFETY

PREVENTING UNINTENDED MOVEMENT



WARNING! If you anticipate being seated in a stationary position for an extended period of time, turn off the power. This will prevent unexpected motion from inadvertent throttle control lever contact.

MOTOR VEHICLE TRANSPORT

Pride recommends that you do not remain seated in your Travel Scooter while traveling in a motor vehicle. The Travel Scooter should be stowed in the boot of a car or in the back of a truck or van with the batteries removed and/or properly secured. In addition, all removable Travel Scooter parts, including the armrests, seat and shroud should be removed and/or properly secured during motor vehicle transport.

WARNING! Although your Travel Scooter may be equipped with a positioning belt, this belt is not designed to provide restraint during motor vehicle transport. Anyone travelling in a motor vehicle should be properly secured in the motor vehicle seat with safety belts fastened securely.



WARNING! Do not sit on your Travel Scooter while it is in a moving vehicle.

WARNING! Always be sure your Travel Scooter and its batteries are properly secured when it is being transported. Batteries should be secured in an upright position and protective caps should be installed on the battery terminals. Batteries should not be transported with any flammable or combustible items.

GETTING ONTO AND OFF OF YOUR TRAVEL SCOOTER

Getting onto and off of your Travel Scooter requires a good sense of balance. Please observe the following safety tips when getting onto and off of your Travel Scooter:

- Remove the key from the key switch.
- Ensure that your Travel Scooter is not in freewheel mode. See III. “Your Travel Scooter.”
- Make certain that the seat is secured into place.
- Pivot the armrests up to make getting onto and off of the Travel Scooter easier.

WARNING! Position yourself as far back as possible in the Travel Scooter seat to prevent the Travel Scooter from tipping and causing injury.



WARNING! Avoid putting all of your weight on the Travel Scooter armrests and do not use the armrests for weight bearing purposes, such as transfers. Such use may cause the Travel Scooter to tip, resulting in a fall from the Travel Scooter and personal injury.

WARNING! Avoid putting all of your weight on the floorboard. Such use may cause the Travel Scooter to tip.

REACHING AND BENDING

Avoid reaching or bending while driving your Travel Scooter. Bending forward creates the risk of accidental throttle control lever contact. Bending to the side while seated creates the risk of tipping. It is important to maintain a stable centre of gravity and keep the Travel Scooter from tipping. Pride recommends that the Travel Scooter user determine his/her personal limitations and practice bending and reaching in the presence of a qualified attendant.



WARNING! Do not bend, lean or reach for objects if you have to pick them up from the Travel Scooter deck or from either side of the Travel Scooter. Movements such as these may change your centre of gravity and the weight distribution of the Travel Scooter and cause your Travel Scooter to tip.



PROHIBITED! Keep your hands away from the tyres when driving. Be aware that loose fitting clothing can become caught in drive tyres.

II. SAFETY

POSITIONING BELTS

Your authorised Pride Dealer, therapist(s) and other healthcare professionals are responsible for determining your requirement for a positioning belt in order to operate your Travel Scooter safely.



WARNING! If you require a positioning belt to safely operate your Travel Scooter, make sure it is fastened securely.

PRESCRIPTION DRUGS/PHYSICAL LIMITATIONS

The Travel Scooter user must exercise care and common sense when operating his/her Travel Scooter. This includes awareness of safety issues when taking prescribed or over-the-counter drugs or when the user has specific physical limitations.



WARNING! Consult your physician if you are taking prescribed or over-the-counter medication or if you have certain physical limitations. Some medications and limitations may impair your ability to operate your Travel Scooter in a safe manner.

ALCOHOL/SMOKING

The Travel Scooter user must exercise care and common sense when operating his/her Travel Scooter. This includes awareness of safety issues while under the influence of alcohol or while smoking.

WARNING! Do not operate your Travel Scooter while you are under the influence of alcohol, as this may impair your ability to drive safely.



WARNING! Pride strongly recommends that you do not smoke cigarettes while seated on your Travel Scooter, although the Travel Scooter seat has passed the necessary testing requirements for cigarette smoking. You must adhere to the following safety guidelines if you decide to smoke cigarettes while seated on your Travel Scooter.

- Do not leave lit cigarettes unattended.
- Keep ashtrays a safe distance from the seat cushions.
- Always make sure cigarettes are completely extinguished before disposal.

FLAMMABILITY PRECAUTIONS

WARNING! Even though the plastics used on your Travel Scooter have been tested and have passed the applicable flammability standards, Pride recommends that you do not expose your Travel Scooter to open flames.



WARNING! Replace worn or damaged upholstery immediately to reduce the risk of fire hazard.

WARNING! Be aware that washing of upholstered items may reduce the resistance to flammability of the fabric.

II. SAFETY

ELECTROMAGNETIC AND RADIO FREQUENCY INTERFERENCE (EMI/RFI)



WARNING! Laboratory tests have shown that electromagnetic and radio frequency waves can have an adverse effect on the performance of electrically-powered mobility vehicles.

Electromagnetic and Radio Frequency Interference can come from sources such as cellular phones, mobile two-way radios (such as walkie-talkies), radio stations, TV stations, amateur radio (HAM) transmitters, wireless computer links, microwave signals, paging transmitters and medium-range mobile transceivers used by emergency vehicles. In some cases, these waves can cause unintended movement or damage to the control system. Every electrically-powered mobility vehicle has an immunity (or resistance) to EMI. The higher the immunity level, the greater the protection against EMI. This product has been tested and has passed at an immunity level of 20 V/M.



WARNING! Be aware that cell phones, two-way radios, laptops and other types of radio transmitters may cause unintended movement of your electrically-powered mobility vehicle due to EMI. Exercise caution when using any of these items while operating your mobility vehicle and avoid coming into close proximity of radio and TV stations.



WARNING! The addition of accessories or components to the electrically-powered mobility vehicle can increase the susceptibility of the vehicle to EMI. Do not modify your Travel Scooter in any way not authorised by Pride.

WARNING! The electrically-powered mobility vehicle itself can disturb the performance of other electrical devices located nearby, such as alarm systems.

NOTE: For further information on EMI/RFI, go to the Resource Centre on www.pridemobility.com. If unintended motion or brake release occurs, turn the Travel Scooter off as soon as it is safe to do so. Contact your authorised Pride Dealer to report the incident.

III. YOUR TRAVEL SCOOTER

TILLER CONSOLE

The tiller console houses all controls needed to drive your Travel Scooter, including the key switch, throttle control lever, horn button, speed adjustment dial and the battery condition meter. See figure 4.



PROHIBITED! Do not expose the tiller console to moisture. In the event that the tiller console does become exposed to moisture, do not attempt to operate your Travel Scooter until the tiller console has dried thoroughly.

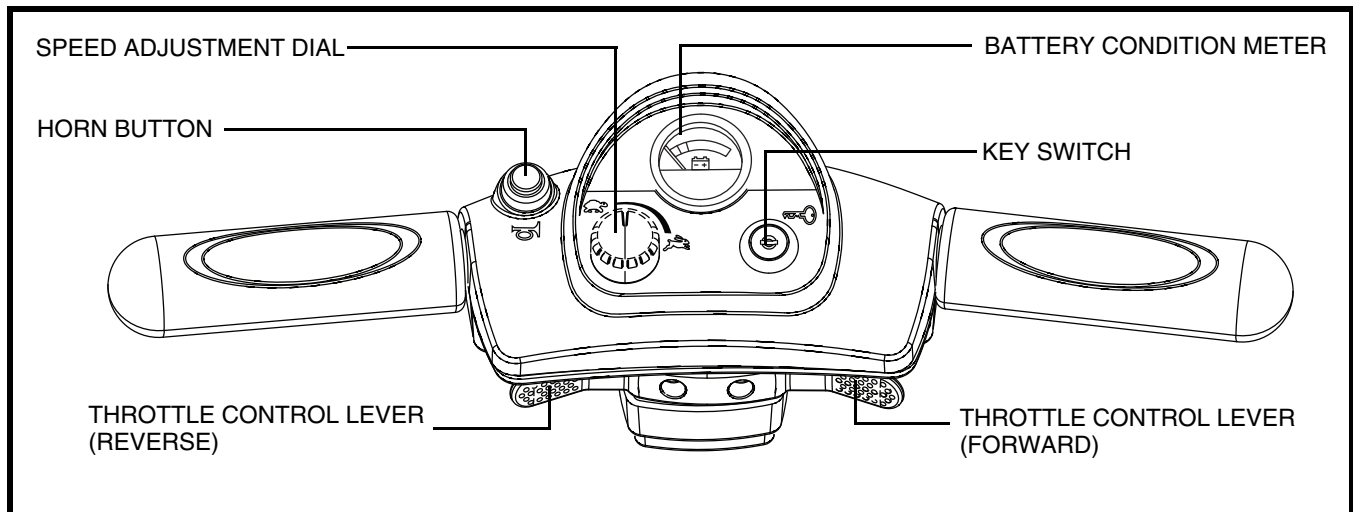

Figure 4. Tiller Console Components

Key Switch

- Insert the key into the key switch and turn it clockwise to power up (turn on) your Travel Scooter.
- Turn the key anticlockwise to power down (turn off) your Travel Scooter.

Although the key can be left in the key switch when the Travel Scooter is powered down, it is recommended that it be removed to prevent unauthorised use of your Travel Scooter.



WARNING! If the key is turned to the “off” position while your Travel Scooter is in motion, the electronic brakes will engage and your Travel Scooter will come to an abrupt stop!

Throttle Control Lever

This lever allows you to control the forward speed and the reverse speed of your Travel Scooter up to the maximum speed you preset with the speed adjustment dial.

- Place your right hand on the right handgrip and your left hand on the left handgrip.
- Use your right thumb to push the right side of the lever to disengage your Travel Scooter’s brakes and move forward.
- Release the lever and allow your Travel Scooter to come to a complete stop before pushing the other side of the lever to move in reverse.
- When the throttle is completely released, it automatically returns to the centre “stop” position and engages your Travel Scooter’s brakes.

Horn Button

This button activates a warning horn. Your Travel Scooter must be powered up for the horn to be operational. Do not hesitate to use the warning horn when doing so may prevent accident or injury.

III. YOUR TRAVEL SCOOTER

Speed Adjustment Dial

This dial allows you to preselect and limit your Travel Scooter's top speed.

- The image of the tortoise represents the slowest speed setting.
- The image of the hare represents the fastest speed setting.

Battery Condition Meter

When the key is fully inserted into the key switch and turned clockwise to power up your scooter, this meter indicates approximate battery strength. For further information on the battery condition meter, see IV. "Batteries and Charging."

Charger Power Lead Receptacle

The 3-pin end of the charger power lead plugs into this receptacle. See figure 5.

Off-Board Charger Fuse

The fuse located on the underside of the tiller console protects the batteries during charging. See figure 6. In the event the batteries will not charge, check this fuse. See VIII. "Basic Troubleshooting" for fuse replacement instructions.

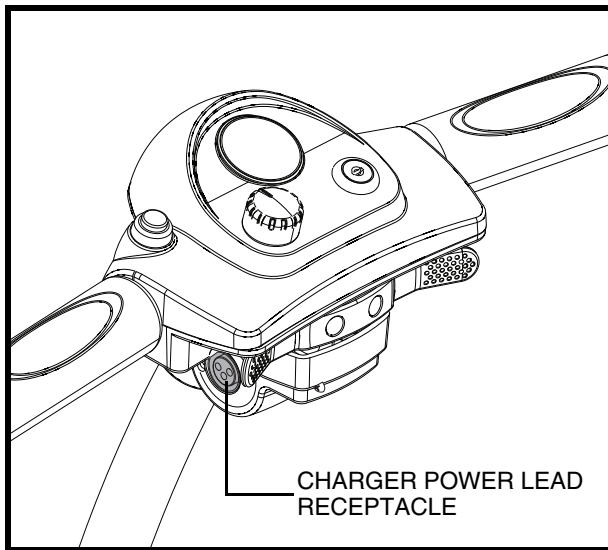

Figure 5. Charger Power Lead Receptacle

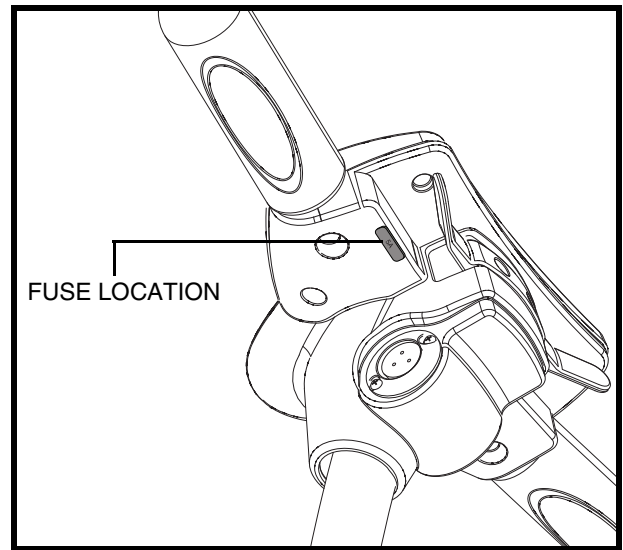

Figure 6. Off-board Charger Fuse

III. YOUR TRAVEL SCOOTER

REAR SECTION

The manual freewheel lever, anti-tip wheels and motor/transaxle assembly are located on the rear section of your Travel Scooter. See figure 7.



WARNING! Before placing your Travel Scooter into or taking it out of freewheel mode, remove the key from the key switch. Never sit on a Travel Scooter when it is in freewheel mode. Never put a Travel Scooter in freewheel mode on any incline.

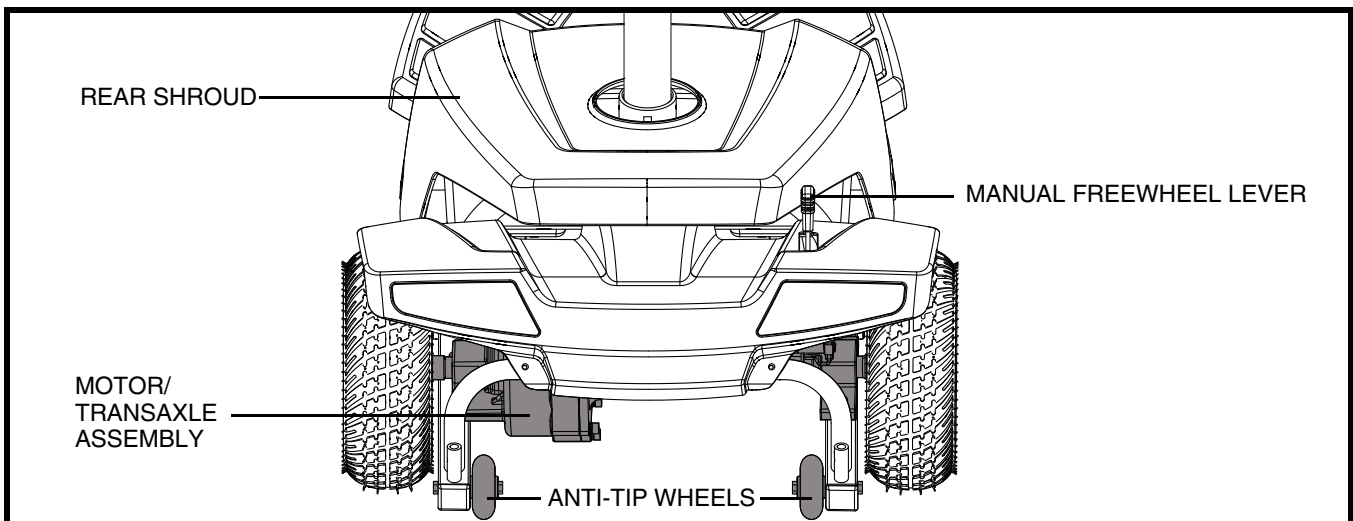

Figure 7. Rear Section

Manual Freewheel Lever

Whenever you need or want to push your Travel Scooter for short distances, you can put it in freewheel mode.

1. Remove the key from the key switch.
2. Locate the manual freewheel lever at the top right of the rear section.
3. Push forward on the manual freewheel lever to disable the drive system and the brake system. This will enable you to push your Travel Scooter.
4. Pull back on the manual freewheel lever to reengage the drive and the brake systems and take your Travel Scooter out of freewheel mode.

WARNING! When your Travel Scooter is in freewheel mode, the braking system is disengaged.



- Disengage the drive motors only on a level surface.
- Ensure the key is removed from the key switch.
- Stand to the side of the Travel Scooter to engage or disengage freewheel mode. Never sit on a Travel Scooter to do this.
- After you have finished pushing your Travel Scooter, always return it to the drive mode to lock the brakes.

NOTE: If the Travel Scooter is placed in freewheel mode (manual freewheel lever forward) while the key is in the “on” position, the Travel Scooter will not run until the manual freewheel lever is pushed rearward and the key is turned to the “off” position, then back to the “on” position.

III. YOUR TRAVEL SCOOTER

Anti-Tip Wheels

The anti-tip wheels are an integral and important safety feature of your Travel Scooter. They are bolted to the frame at the rear of the Travel Scooter.



PROHIBITED! Do not remove the anti-tip wheels or modify your Travel Scooter in any way that is not authorised by Pride.



WARNING! The anti-tip wheels may cause interference with the smooth transition of your Travel Scooter when ascending or descending a kerb. Contact your authorised Pride Dealer for more information.

Motor/Transaxle Assembly

The motor/transaxle assembly is an electromechanical unit that converts electrical energy from your Travel Scooter's batteries into the controlled mechanical energy that drives the Travel Scooter's wheels.

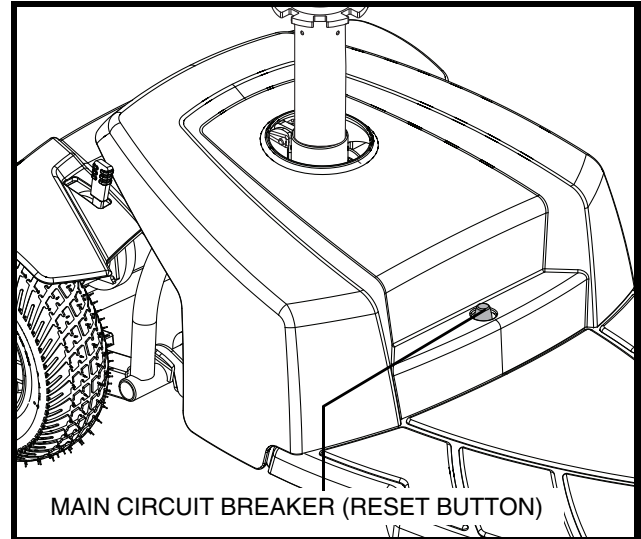

Figure 8. Main Circuit Breaker (Reset Button)

Main Circuit Breaker (Reset Button)

When the voltage in your Travel Scooter's batteries becomes low or the Travel Scooter is heavily strained because of excessive loads or steep inclines, the main circuit breaker may trip to protect the motor and electronics from damage. See figure 8.

- The main circuit breaker reset button pops out when the breaker trips.
- When the breaker trips, the entire electrical system of your Travel Scooter shuts down.
- Allow a minute or two for your Travel Scooter's electronics to "rest."
- Push in the reset button to reset the main circuit breaker.
- If the main circuit breaker trips frequently, you may need to charge your batteries more often or have your authorised Pride Dealer perform a load test on your Travel Scooter's batteries.
- If the main circuit breaker trips repeatedly, see your authorised Pride Dealer for service.

BATTERY PACK

Your Travel Scooter is equipped with an innovative, easy to remove battery pack that is located under the rear shroud. A handle on the top of the battery pack makes it easy to lift the pack off of the Travel Scooter with one hand. The battery pack contains two rechargeable batteries that store electrical energy that powers your Travel Scooter. See figure 9.

OFF-BOARD BATTERY CHARGER

The off-board battery charger, when plugged into the charger power lead receptacle and a standard electrical outlet, charges the Travel Scooter's batteries. See figure 10 and 10A.

III. YOUR TRAVEL SCOOTER

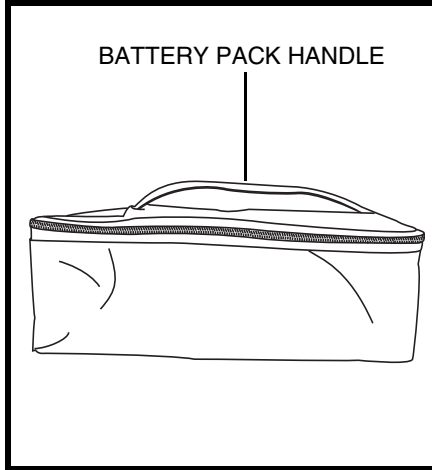

Figure 9. Battery Pack

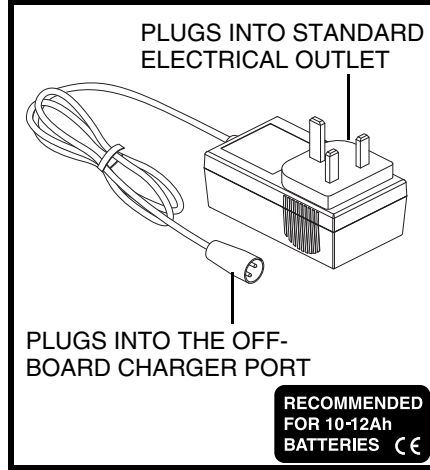

Figure 10. Battery Charger (10 Ah battery pack)

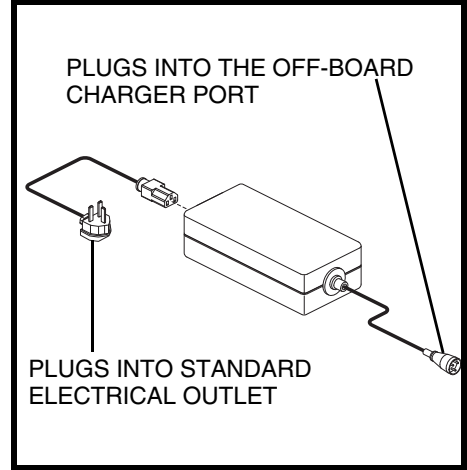

Figure 10A. Battery Charger (15 Ah battery pack)

SECURING THE SCOOTER

Always secure the Travel Scooter in a forward-facing position in the vehicle. Attach the four tie-down straps to the designated securement points. See figures 11 and 12. Tighten the straps to sufficiently remove all slack. Never attach tie-downs to adjustable, moving, or removable parts of the Travel Scooter such as armrests, shrouds, and wheels. These items should be removed. Position the anchor points for the rear tie-down straps directly behind the rear securement points on the Travel Scooter. The front tie-down straps should anchor to floor points that are spaced wider than the Travel Scooter to provide increased lateral stability.



WARNING! Ensure Travel Scooters are properly secured to the motor vehicle during transport. Scooters that are not properly secured can become a hazard to the user and to other vehicle passengers in the event of a crash, sudden stopping or swerving, as the Travel Scooter could tip or slide out of place.

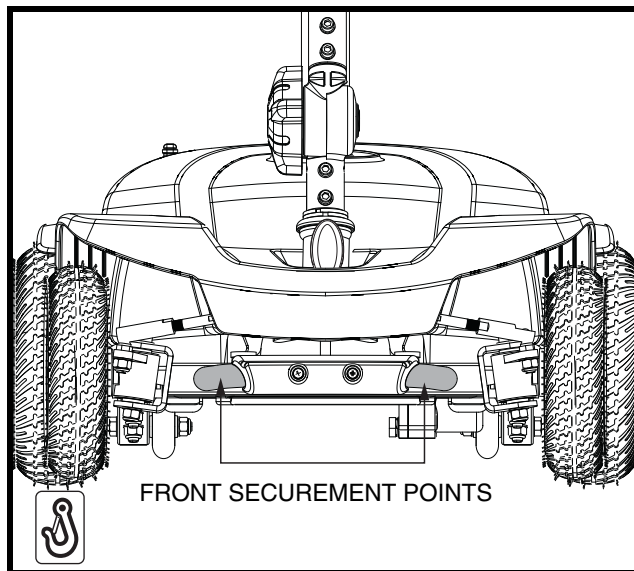

Figure 11. Front Securement Points

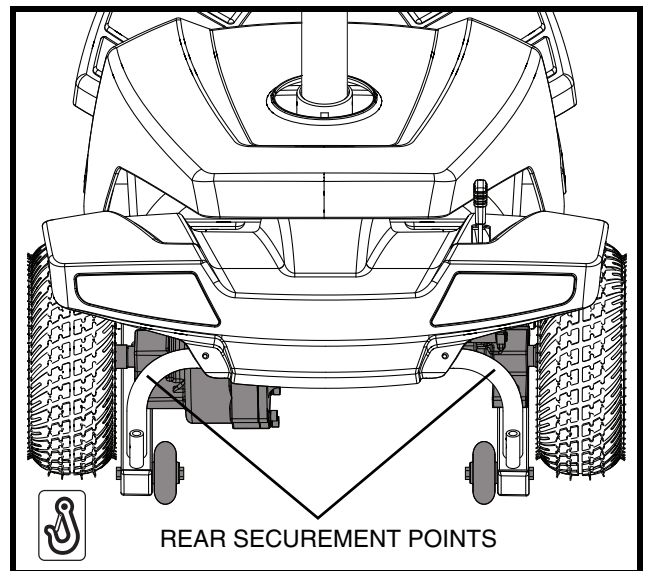

Figure 12. Rear Securement Points

IV. BATTERIES AND CHARGING

BATTERIES AND CHARGING

Your Travel Scooter requires two long-lasting, 12-volt, deep-cycle batteries that are sealed and maintenance free. They are recharged by the supplied off-board charging system.

- Charge your Travel Scooter's batteries for 8 to 14 hours prior to using it for the first time.
- Keep the batteries fully charged to keep your Travel Scooter running smoothly.

READING YOUR BATTERY VOLTAGE

The battery condition meter on the tiller console indicates the approximate strength of your batteries using a colour code. From right to left on the meter, green indicates fully charged batteries, yellow a draining charge, and red indicates that an immediate recharge is necessary. See figure 13. To ensure the highest accuracy, the battery condition meter should be checked while operating your Travel Scooter at full speed on a dry, level surface.

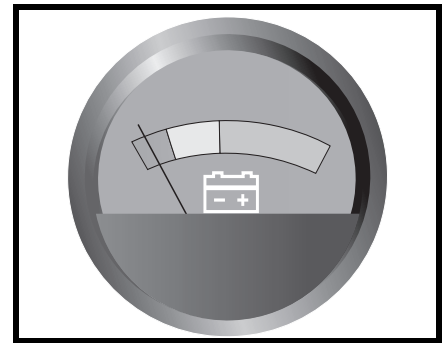

Figure 13. Battery Condition Meter

CHARGING YOUR BATTERIES



PROHIBITED! Removal of grounding prong can create electrical hazard. If necessary, properly install an approved 3-pronged adapter to an electrical outlet having 2-pronged plug access.



PROHIBITED! Never use an extension lead to plug in your battery charger. Plug the charger directly into a properly wired standard electrical outlet.



PROHIBITED! Do not allow unsupervised children to play near the Travel Scooter while the batteries are charging. Pride recommends that you do not charge the batteries while the Travel Scooter is occupied.



MANDATORY! Read the battery charging instructions in this manual and in the manual supplied with the battery charger before charging the batteries.



WARNING! Explosive gases may be generated while charging the batteries. Keep the Travel Scooter and battery charger away from sources of ignition such as flames or sparks and provide adequate ventilation when charging the batteries.

WARNING! You must recharge your Travel Scooter's batteries with the supplied off-board charger. Do not use an automotive-type battery charger.

WARNING! Inspect the battery charger, wiring and connectors for damage before each use. Contact your authorised Pride Dealer if damage is found.



WARNING! Do not attempt to open the battery charger case. If the battery charger does not appear to be working correctly, contact your authorised Pride Dealer.

WARNING! If the battery charger is equipped with cooling slots, then do not attempt to insert objects through these slots.

WARNING! Be aware that the battery charger case may become hot during charging. Avoid skin contact and do not place on surfaces that may be affected by heat.



WARNING! If your battery charger has not been tested and approved for outdoor use, then do not expose it to adverse or extreme weather conditions. If the battery charger is exposed to adverse or extreme weather conditions, then it must be allowed to adjust to the difference in environmental conditions before use indoors. Refer to the manual supplied with the battery charger for more information.

IV. BATTERIES AND CHARGING

Follow these easy steps to charge your batteries safely:

1. Position your Travel Scooter close to a standard electrical outlet. See figure 14 and 14A.
2. Remove the key from the key switch.
3. Make certain that the manual freewheel lever is in the drive (rearward) position.
4. Plug the charger power lead into the charger power lead receptacle on your Travel Scooter, then into the electrical outlet. We recommend that you charge the batteries for 8 to 14 hours.

NOTE: The LED lights on the charger indicate different charger conditions at various times: charger power on, charging in progress and charging complete. Refer to the operating instructions supplied with the charger for a complete explanation of these indicators.

5. When the batteries are fully charged, unplug the charger power lead from the electrical outlet and then from the charger power lead receptacle.

NOTE: There is a charger inhibit function on your Travel Scooter. The Travel Scooter will not run and the battery condition meter will not operate while the batteries are charging.

FREQUENTLY ASKED QUESTIONS

How does the charger work?

When your Travel Scooter's battery voltage is low, the charger works harder, sending more electrical current to the batteries to bring up their charge. As the batteries approach a full charge, the charger sends less and less electrical current. When the batteries are fully charged, the current sent from the charger is at nearly zero amperage. Therefore, when the charger is plugged in, it maintains the charge on your Travel Scooter's batteries, but does not overcharge them. We do not recommend that you charge your Travel Scooter's batteries for more than 24 consecutive hours.

What if my Travel Scooter's batteries will not charge?

- Ensure that the fuse on the tiller console is in working condition. See figure 6.
- Ensure both ends of the charger power lead are inserted fully.

Can I use a different charger?

Chargers are selected precisely for particular applications and are especially matched to the type, size and chemical formulation of specific batteries. For the safest and most efficient charging of your Travel Scooter's batteries, we recommend use of the charger supplied as original equipment with your Pride product only. Any charging method resulting in batteries being charged individually is especially prohibited.

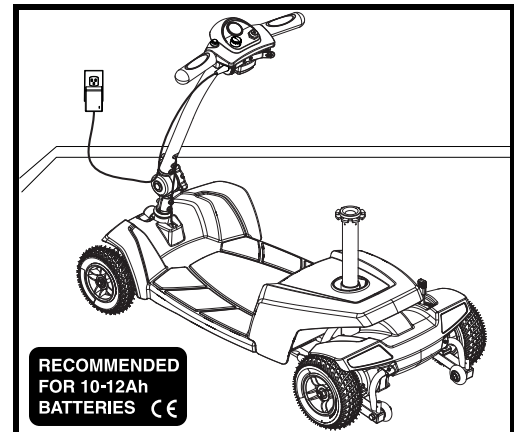

Figure 14. Charging The Batteries (10 Ah)

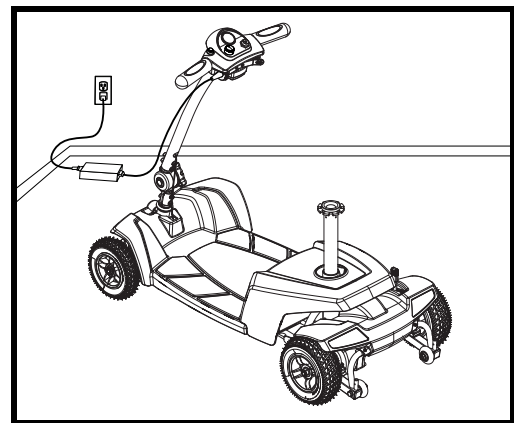

Figure 14A. Charging The Batteries (15 Ah)

IV. BATTERIES AND CHARGING

How often must I charge the batteries?

Two major factors must be considered when deciding how often to charge your Travel Scooter's batteries:

- All day use on a daily basis.
- Infrequent or sporadic use.

With these considerations in mind, you can determine how often and for how long you should charge your Travel Scooter's batteries. The battery charger was designed so that it will not overcharge your Travel Scooter's batteries. However, you may encounter some problems if you do not charge your batteries often enough and if you do not charge them on a regular basis. Following the guidelines below will provide safe and reliable battery operation and charging.

- If you use your Travel Scooter daily, charge its batteries as soon as you finish using it for the day. Your Travel Scooter will be ready each morning. We recommend that you charge your Travel Scooter's batteries for 8 to 14 hours after daily use.
- If you use your Travel Scooter once a week or less, charge its batteries at least once a week for 12 to 14 hours at a time.
- Keep your Travel Scooter's batteries fully charged.
- Avoid deeply discharging your Travel Scooter's batteries.

How can I ensure maximum battery life?

Fully charged deep-cycle batteries provide reliable performance and extended battery life. Keep your Travel Scooter's batteries fully charged whenever possible. Protect your Travel Scooter and batteries from extreme heat or cold. Batteries that are regularly and deeply discharged, infrequently charged, stored in extreme temperatures or stored without a full charge may be permanently damaged, causing unreliable performance and limited service life.

How can I get maximum range or distance per charge?

Rarely will you have ideal driving conditions—smooth, flat, hard driving surfaces with no wind or curves. Often, you will face hills, pavement cracks, uneven and loosely packed surfaces, curves and wind, all of which affect the distance or running time per battery charge. Below are a few suggestions for obtaining the maximum range per battery charge.

- Always fully charge your Travel Scooter's batteries prior to daily use.
- Maintain but do not exceed the psi/bar/kPa air pressure rating indicated on each tyre.
- Plan your route ahead to avoid as many hills, cracked, broken or soft surfaces as possible.
- Limit your baggage weight to essential items.
- Try to maintain an even speed while your Travel Scooter is in motion.
- Avoid stop-and-go driving.

What type and size of battery should I use?

Your Travel Scooter requires two deep cycle batteries. We recommend only sealed, maintenance-free types such as AGM or Gel-Cell. Do not use wet-cell batteries, which have removable caps. Refer to the specifications table for size as batteries differ depending on manufacturer.



WARNING! Corrosive chemicals are contained in batteries. Use only AGM or Gel-Cell batteries to reduce the risk of leakage or explosive conditions.

NOTE: *Sealed batteries are not serviceable. Do not remove the caps.*

IV. BATTERIES AND CHARGING

How do I change a battery in my Travel Scooter?



MANDATORY! Battery posts, terminals and related accessories contain lead and lead compounds. Wear goggles and gloves when handling batteries and wash hands after handling.



WARNING! Always use two batteries of the exact same type, chemistry and amp-hour (Ah) capacity. Refer to the specifications table provided with this manual and in the manual supplied with the battery charger for recommended type and capacities.

WARNING! Do not mix old and new batteries. Always replace both batteries at the same time.



WARNING! Contact your authorised Pride Dealer if you have any questions regarding the batteries in your Travel Scooter.

WARNING! Do not replace the batteries while the Travel Scooter is occupied.

WARNING! The batteries on your Travel Scooter should only be serviced or replaced by an authorised Pride Dealer or a qualified technician.



PROHIBITED! Keep tools and other metal objects away from battery terminals. Contact with tools can cause electrical shock.

You may need the following to change your batteries:

- Metric/standard socket set and ratchet
- Adjustable spanner



WARNING! Do not lift beyond your physical capability. Ask for assistance when necessary while disassembling or assembling your scooter.

1. Remove the seat and rear shroud.
2. Disconnect the battery harnesses and tie-down strap then remove the battery pack from the Travel Scooter. See figure 15.
3. Unzip the battery pack to expose the batteries. See figure 16.
4. Disconnect the black (-) and red (+) battery cables from the battery terminals of each battery. See figure 16.



WARNING! Do not pull on electrical harness wires directly to detach them from the Travel Scooter. Always grasp the connector itself when disconnecting the harness to prevent wire damage.

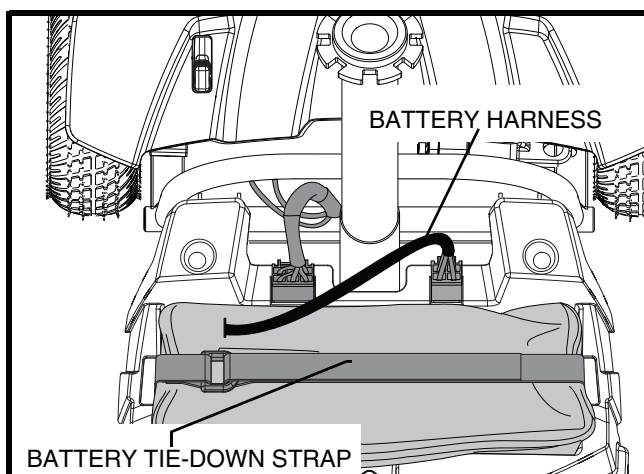

Figure 15. Battery Tie-down Strap

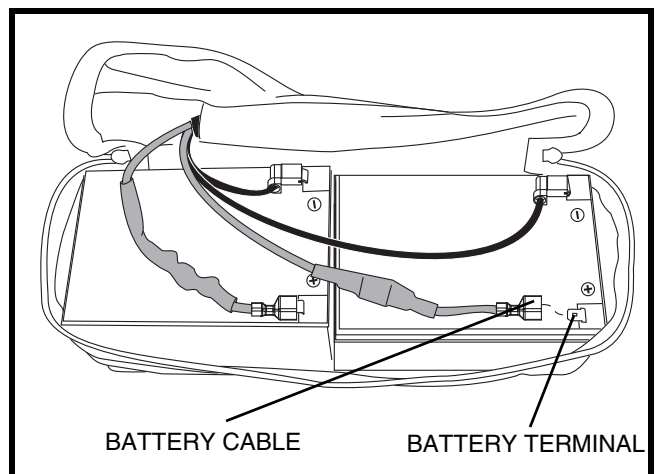

Figure 16. Battery Replacement

IV. BATTERIES AND CHARGING

5. Remove the old batteries.
6. Place the new batteries into the battery pack.
7. Connect the red battery cable to the positive (+) battery terminal of each battery.
8. Connect the black battery cable to the negative (-) battery terminal of each battery.
9. Completely zip the battery pack closed.
10. Reinstall the battery pack then connect the battery harnesses and battery tie-down strap.
11. Reinstall the rear shroud and seat.

NOTE: If you encounter a damaged or cracked battery, immediately enclose it in a plastic bag and contact your local waste disposal agency or authorised Pride Dealer for instructions on disposal and battery recycling which is our recommended course of action.

Why do my new batteries seem weak?

Deep-cycle batteries employ a different chemical technology than that used in car batteries, nickel-cadmium batteries (nicads), and other common battery types. Deep-cycle batteries are specifically designed to provide power, drain down their charge, and then accept a relatively quick recharge (8 to 14 hours).

We work closely with our battery manufacturer to provide batteries that best suit your Travel Scooter's specific electrical demands. Fresh batteries are shipped fully charged to our customers. During shipping, the batteries may encounter temperature extremes that can influence their initial performance. Heat diminishes the charge on the battery; cold slows the available power and extends the time needed to recharge the battery.

It may take a few days for the temperature of your Travel Scooter's batteries to stabilise and adjust to their new room or ambient temperature. More importantly, it takes a few charging cycles (partial draining followed by full recharging) to establish the critical chemical balance that is essential to a deep-cycle battery's peak performance and long life.

Follow these steps to properly break in your Travel Scooter's new batteries for maximum efficiency and service life:

1. Fully recharge any new battery prior to its initial use. This charging cycle brings the battery up to about 88% of its peak performance level.
2. Operate your new Travel Scooter in familiar and safe areas. Drive slowly at first and do not travel too far from your home or familiar surroundings until you have become accustomed to your Travel Scooter's controls and have properly broken in your Travel Scooter's batteries.
3. Fully recharge the batteries. They should be at over 90% of their peak performance level.
4. Operate your Travel Scooter again, then fully charge the batteries.
5. After four or five charging cycles, the batteries are able to receive a charge of 100% of their peak performance level and are able to last for an extended period of time.

What about public transport?

If you intend to use public transportation with your Travel Scooter, you must contact the transportation provider in advance to determine their specific requirements.

V. OPERATION

BEFORE GETTING ONTO YOUR TRAVEL SCOOTER

- Have you fully charged the batteries? See IV. “Batteries and Charging.”
- Is the manual freewheel lever in the drive (rearward) position? Never leave the manual freewheel lever in the forward position unless you are manually pushing your Travel Scooter.
- Ensure the tiller lock knob is in the unlocked position. See VII. “Disassembly and Assembly.”

GETTING ONTO YOUR TRAVEL SCOOTER

1. Make certain that the key is removed from the key switch.



WARNING! Never attempt to get onto or off of your Travel Scooter without first removing the key from the key switch. This will prevent the Travel Scooter from moving if accidental throttle control lever contact is made.

2. Stand at the side of your Travel Scooter.
3. Disengage the seat rotation lever and rotate the seat until it is facing you.
4. Make certain that the seat is secured into position.
5. Position yourself comfortably and securely in the seat.
6. Disengage the seat rotation lever and rotate the seat until you are facing forward.
7. Make certain that the seat is secured into position.
8. Make certain that your feet are safely on the floorboard.

PRE-RIDE ADJUSTMENTS AND CHECKS

- Is the seat at the proper height? See VI. “Comfort Adjustments.”
- Is the seat fixed securely in position?
- Is the tiller at a comfortable setting and locked secured into place? See VI. “Comfort Adjustments.”
- Is the key fully inserted into the key switch and turned clockwise to the “on” position?
- Does the Travel Scooter’s horn work properly?
- Is your proposed path clear of people, pets and obstacles?
- Have you planned your route to avoid adverse terrain and as many inclines as possible?

OPERATING YOUR TRAVEL SCOOTER

WARNING! The following can adversely affect steering and stability while operating your Travel Scooter, resulting in loss of control, tipping and/or personal injury:



- Holding onto or attaching a leash to walk your pet
- Carrying passengers (including pets)
- Hanging any article from the tiller
- Towing or being pushed by another motorised vehicle

WARNING! Keep both hands on the tiller and your feet on the floorboard at all times while operating your Travel Scooter. This driving position gives you the most control over your vehicle.

- Set the speed adjustment dial to your desired speed.
- Press your thumb against the appropriate side of the throttle control lever.
- The electromechanical disc park brake automatically disengages and the Travel Scooter accelerates smoothly to the speed you preselected with the speed adjustment dial.
- Pull on the left handgrip to steer your Travel Scooter to the left.
- Pull on the right handgrip to steer your Travel Scooter to the right.
- Move the tiller to the centre position to drive straight ahead.
- To stop, slowly release the throttle control lever. The electronic brakes will automatically engage when your Travel Scooter comes to a stop.

V. OPERATION

NOTE: Your Travel Scooter's reverse speed is slower than that of the forward speed you preset with the speed adjustment dial.

GETTING OFF OF YOUR TRAVEL SCOOTER

1. Bring your Travel Scooter to a complete stop.
2. Power down your Travel Scooter and remove the key from the key switch.
3. Disengage the seat rotation lever and rotate the seat until you are facing toward the side of your Travel Scooter.
4. Make certain that the seat is fixed securely in position.
5. Carefully and safely get out of the seat and stand to the side of your Travel Scooter.
6. You can leave the seat facing to the side to facilitate boarding your Travel Scooter next time.

POWER DOWN TIMER FEATURE

Your Travel Scooter is equipped with an energy saving automatic power down timer feature designed to preserve your Travel Scooter's battery life. If you mistakenly leave the key in the key switch and in the "on" position but do not use your Travel Scooter for approximately 20 minutes, the Travel Scooter's controller shuts down automatically.

If the power down timer feature takes effect, perform the following steps to resume normal operation:

1. Remove the key from the key switch.
2. Reinsert the key and power up your Travel Scooter.

VI. COMFORT ADJUSTMENTS

TILLER ANGLE ADJUSTMENT



WARNING! Remove the key from the key switch before adjusting the tiller or the seat. Never attempt to adjust the tiller or the seat while the Travel Scooter is in motion.

Your Travel Scooter is equipped with an adjustable pivoting tiller.

1. While supporting the tiller, turn the tiller adjustment knob anticlockwise to loosen the tiller. **See figure 17.**
2. Move the tiller to a comfortable position.
3. Turn the tiller adjustment knob clockwise to secure the tiller in position.

NOTE: In order to fully lower the tiller, you must first remove the seat. Remove the seat by pulling it straight up and off of the Travel Scooter.

SEAT ROTATION ADJUSTMENT

The seat rotation lever, located on the right side of the seat base, secures the seat into several positions. **See figure 18.**

1. Pull up on the seat rotation lever to disengage the seat.
2. Rotate the seat to the desired position.
3. Release the lever to secure the seat into place.

ARMREST WIDTH ADJUSTMENT

The armrest width can be adjusted inward or outward.

1. Loosen the armrest adjustment knobs. **See figure 18.**
2. Use the attached ring to pull and remove the detent pins.
3. Slide the armrests in or out to the desired width.
4. Align the adjustment holes on the seat frame and armrest, then reinsert the detent pins.
5. Tighten the armrest adjustment knobs.

NOTE: Pivot the armrests upward to aid in getting onto and off of your Travel Scooter.

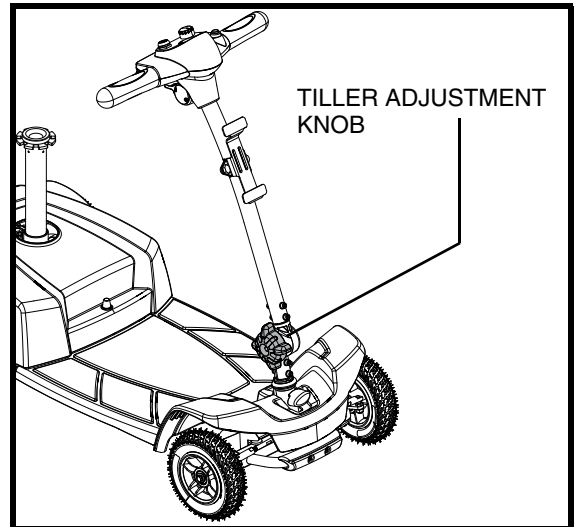

Figure 17. Tiller Adjustment Knob

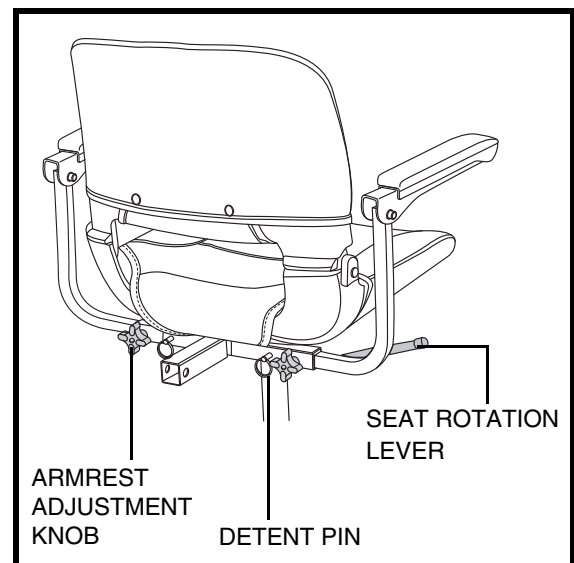

Figure 18. Seat Adjustments

VI. COMFORT ADJUSTMENTS

SEAT HEIGHT ADJUSTMENT

The seat can be repositioned to different heights. See **figure 19**.

1. Remove the seat from your Travel Scooter.
2. Remove the rear shroud from your Travel Scooter.
3. Disconnect the battery harnesses.
4. Disconnect the battery tie-down strap and remove the battery pack.
5. Use the attached ring to pull and remove the detent pin from the lower seat post.
6. Raise or lower the upper seat post to the desired seat height.
7. While holding the upper seat post at that height, align the adjustment holes of the upper and lower seat posts.
8. Fully insert the detent pin.
9. Replace the battery pack and connect the battery harnesses.
10. Fasten the battery tie-down strap.
11. Reinstall the rear shroud.
12. Reinstall the seat.

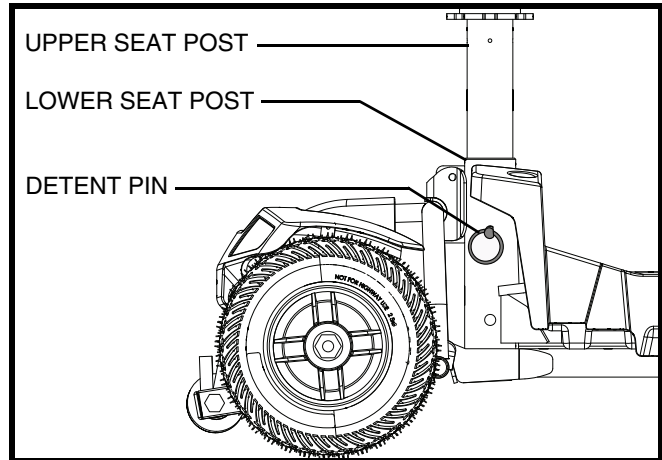

Figure 19. Seat Height Adjustment

VII. DISASSEMBLY AND ASSEMBLY

DISASSEMBLY

You can disassemble the Travel Scooter into six pieces: the seat, the front section, the rear section, the rear shroud, the basket, and the battery pack. See figure 20. No tools are required to disassemble or assemble your Travel Scooter, but keep in mind that the disassembled sections of the scooter take up more floor space than the assembled unit. Always disassemble or assemble your Travel Scooter on a level, dry surface with sufficient room for you to work and move around—about 1.5 metres (5 feet) in all directions. Remember that some Travel Scooter components are heavy and you may need assistance when lifting them.

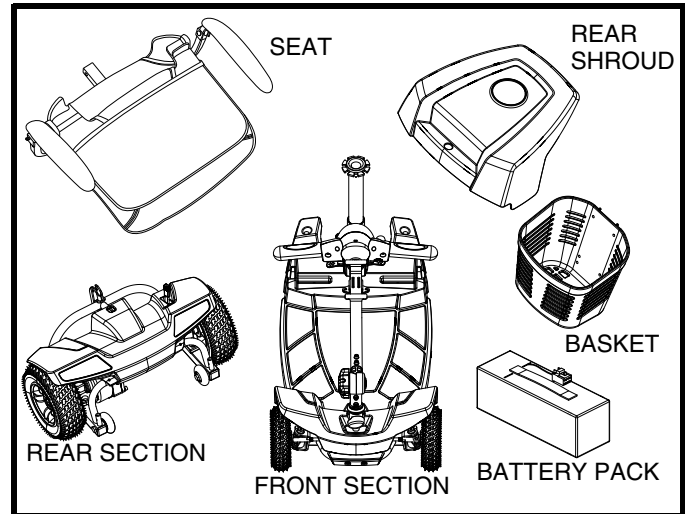

Figure 20. Disassembled Travel Scooter



WARNING! Do not lift weight beyond your physical capability. Ask for assistance when necessary while disassembling or assembling your Travel Scooter.

1. Remove the key from the key switch.
2. Lock the tiller in the straight ahead position by pushing the tiller lock knob in and turning it clockwise 90°. See figure 21. The front wheel must face forward in order to lock the tiller.
3. Remove the seat by lifting it straight up and off of the Travel Scooter. If you encounter resistance when removing the seat, disengage the seat rotation lever and swivel the seat back and forth while lifting up on the seat.
4. Remove the rear shroud by lifting it straight up and off of the Travel Scooter.
5. Disconnect the battery harness. See figure 23.
6. Disconnect the front-to-rear harness. See figure 23.
7. Disconnect the battery tie-down strap.
8. Remove the battery pack from the Travel Scooter by lifting it straight up and off of the Travel Scooter.



WARNING! Failure to unplug both battery harnesses prior to separating the front and rear sections could result in permanent damage to the scooter.

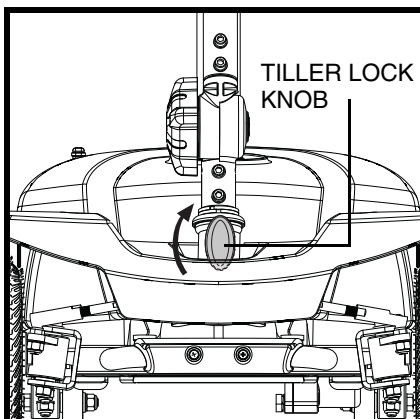

Figure 21. Tiller Lock knob (Locked)

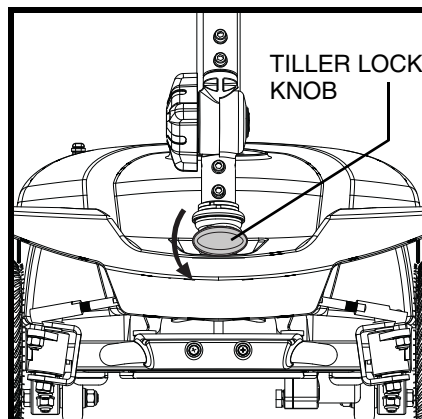

Figure 22. Tiller Lock knob (Unlocked)

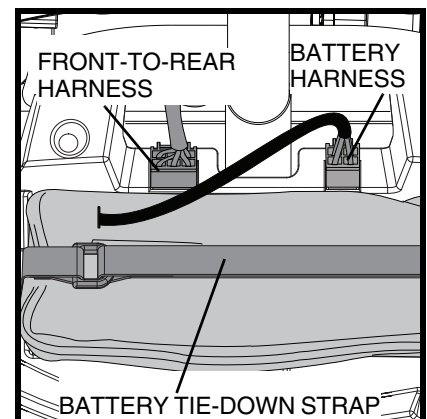

Figure 23. Harness Connections

VII. DISASSEMBLY AND ASSEMBLY

Frame Separation

1. Lower the tiller and tighten the tiller adjustment knob.
2. Remove the frame lock-up pin. **See figure 24.**
3. Lift up on the seat post and pivot the rear section rearward until the frame hooks are no longer resting on the lower frame tube.
4. Slowly separate the two sections of the Travel Scooter. **See figure 25.**

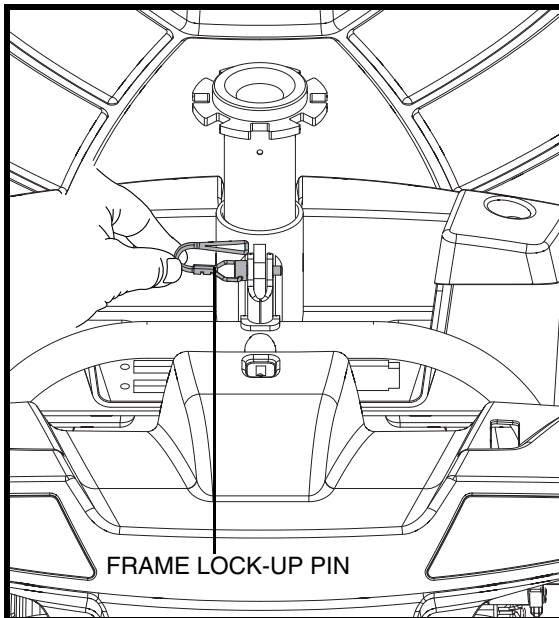

Figure 24. Frame Lock-Up Pin

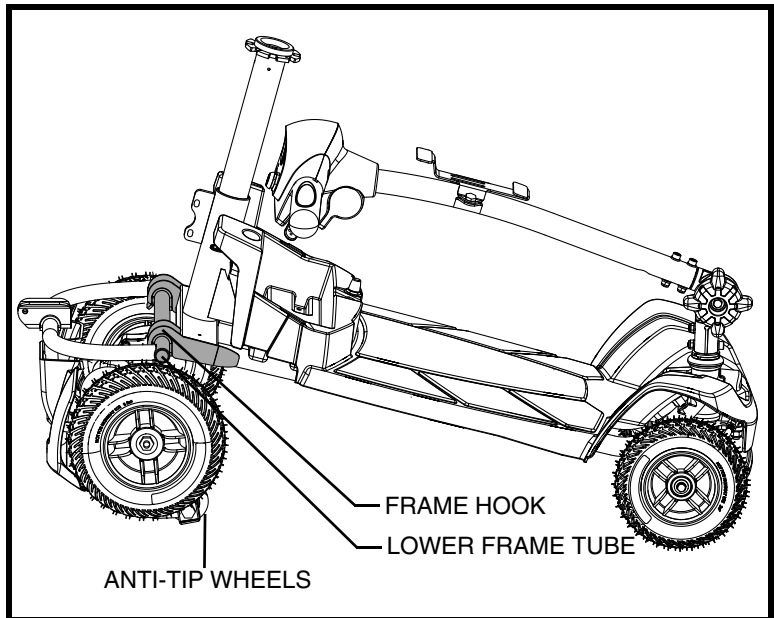

Figure 25. Frame Separation

ASSEMBLY

NOTE: Before attempting assembly, tilt the rear half of the Travel Scooter slightly back on the anti-tip wheels as show in figure 25.

1. Use the seat post to lift the front section as you align the frame hooks of the front section with the lower frame tube of the rear section. **See figure 25.**
2. Once the frame hooks are over the lower frame tube, lower the front section completely.
3. Pivot the rear section forward; this will engage the frame lock up.
4. Reinstall the frame lock-up pin.
5. Raise the tiller and fully tighten the tiller adjustment knob.
6. Reinstall the battery pack.
7. Reconnect the battery and front-to-rear harnesses.
8. Reinstall the seat and rotate it until it is secured into place.
9. Unlock the front wheel by turning the tiller lock knob 90° anticlockwise. **See figure 22.**



WARNING! After assembly, make absolutely certain the tiller lock knob is in the unlocked position before driving the Travel Scooter.

VIII. BASIC TROUBLESHOOTING

Any electromechanical device occasionally requires some troubleshooting. However, most of the problems that may arise can usually be solved with a bit of thought and common sense. Many of these problems occur because the batteries are not fully charged or because the batteries are worn down and can no longer hold a charge.

DIAGNOSTIC BEEP CODES

The diagnostic beep codes for your Travel Scooter are designed to help you perform basic troubleshooting quickly and easily. A diagnostic beep code will sound in the event one of the conditions listed below develops. A beep code will begin with a series of fast beeps directly followed by slower beeps which indicates the actual code. The beep code is only beeped once. To repeat the beep code, remove the key, then reinsert it and turn it to the “on” position.

NOTE: Your Travel Scooter will not run unless the beep code condition is resolved and the Travel Scooter has been turned off, then turned back on.

BEEP CODE	CONDITION	SOLUTION
■ (1)	Battery charge is low.	Charge batteries as soon as possible.
■ ■ (2)	Battery charge is too low.	Charge batteries.
■ ■ ■ (3)	The Travel Scooter's battery voltage is too high to operate the Travel Scooter or the charger is still connected to the off-board charger port.	Unplug charger and/or turn key off, then back on again.
■ ■ ■ ■ (4)	Current limit time out.	Turn the Travel Scooter off for a few minutes, then turn your Travel Scooter back on.
■ ■ ■ ■ ■ (5)	The manual freewheel lever is in the (forward) freewheel position.	Remove the key from the key switch, then push the manual freewheel lever to the drive (rearward) position and restart your Travel Scooter.
■ ■ ■ ■ ■ ■ (6)	Throttle control lever not at centre position at start up.	Return the throttle control lever to centre position, turn Travel Scooter off then back on.
■ ■ ■ ■ ■ ■ ■ (7)	Speed pot error.	Call your authorised Pride Dealer for assistance.
■ ■ ■ ■ ■ ■ ■ ■ (8)	Motor volts error.	Call your authorised Pride Dealer for assistance.
■ ■ ■ ■ ■ ■ ■ ■ ■ (9)	Other internal errors.	Call your authorised Pride Dealer for assistance.

What if all the systems on my Travel Scooter seem to be “dead”?

- Make certain that the key is in the “on” position.
- Check that the batteries are fully charged.
- Push in the main circuit breaker reset button. See III. “Your Travel Scooter.”
- Make certain that the front-to-rear and battery harnesses are secured properly. See VIII. “Disassembly and Assembly.”
- Be sure the power down timer feature has not been activated. See V. “Operation.”
- Check the fuse located on the underside of the tiller.

VIII. BASIC TROUBLESHOOTING

To check a fuse:

1. Remove the fuse by pulling it out of its slot.
2. Examine the fuse to be sure it is blown. See figures 26 and 27.
3. Insert a new fuse of the proper rating.



WARNING! The replacement fuse must exactly match the rating of the fuse being replaced. Failure to use properly rated fuses may cause damage to the electrical system.

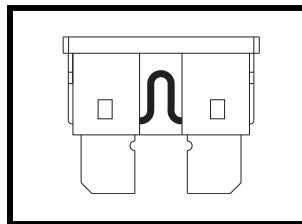

Figure 26. Working Fuse

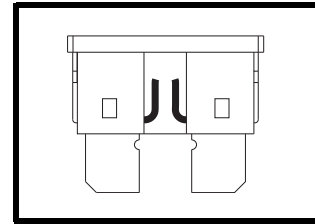

Figure 27. Blown Fuse (Replace)

What if the Travel Scooter's batteries won't charge?

- Check the fuse located on the underside of the tiller console. Replace if necessary.
- During the charging process, if the charger LED's never indicate a full charge, check the fuse located on the underside of the tiller console. Replace if necessary.
- Ensure both ends of the charger power lead are inserted fully.
- Ensure both battery harness and the front-to rear cable are inserted fully into their mating plugs.
- If the tiller console fuse continually blows, contact your authorised Pride Dealer for service.

What if my Travel Scooter does not move when I press the throttle control lever?

- When the manual freewheel lever is pushed forward, the brakes are disengaged and all power to the motor/transaxle assembly is cut.
- Pull back on the manual freewheel lever, turn the Travel Scooter off, and then back on to return to normal operation.

What if the main circuit breaker repeatedly trips?

- If the main circuit breaker trips repeatedly, see your authorised Pride Dealer for service.
- Charge the Travel Scooter's batteries more frequently. See IV. "Batteries and Charging."
- If the problem continues, have both of your Travel Scooter's batteries load tested by your authorised Pride Dealer.
- You may also perform the load test yourself. Battery load testers are available at most automotive parts stores. Follow the directions supplied with the load tester.
- See IV. "Batteries and Charging" or the "Product Specifications" insert for information about your Travel Scooter's battery type.

What if the battery condition meter dips way down and the motor surges or hesitates when I press the throttle control lever?

- Fully charge your Travel Scooter's batteries. See IV. "Batteries and Charging."
- Have your authorised Pride Dealer load test each battery.
- See the previous troubleshooting question for load testing the batteries yourself.

If you experience any problems with your Travel Scooter that you are not able to solve, immediately contact your authorised Pride Dealer for information, maintenance and service.

IX. CARE AND MAINTENANCE

Your Travel Scooter requires a minimal amount of care and maintenance. If you do not feel confident in your ability to perform the maintenance listed below, you may schedule inspection and maintenance at your authorised Pride Dealer. The following areas require periodic inspection and/or care and maintenance.

TYRE PRESSURE

- If equipped with pneumatic tyres, always maintain the psi/bar/kPa air pressure indicated on each tyre.



WARNING! It is important that the psi/bar/kPa air pressure indicated on each tyre be maintained in pneumatic tyres at all times. Do not underinflate or overinflate your tyres. Low pressure may result in loss of control, and overinflated tyres may burst. Failure to maintain the psi/bar/kPa air pressure indicated on pneumatic tyres at all times may result in tyre and/or wheel failure.

- Regularly inspect your Travel Scooter's tyres for signs of wear.

WHEEL REPLACEMENT

If your Travel Scooter is equipped with pneumatic tyres and you have a flat tyre, you can have the tube replaced. If your Travel Scooter is equipped with a solid tyre insert, either the solid insert or the entire wheel must be replaced depending on the model. Contact your authorised Pride Dealer for information regarding replacement wheels for your Travel Scooter.

WARNING! Wheels on your Travel Scooter should only be serviced/replaced by a qualified technician.



WARNING! Be sure that the key is removed from the key switch and the Travel Scooter is not in freewheel mode before performing this procedure.

WARNING! When changing a tyre, remove only the centre lug nut, then remove the wheel. If any further disassembly is required, deflate the tyre completely or it may explode.

Follow these easy steps for a quick and safe repair for solid tyres:

1. Remove the key from the key switch and ensure your Travel Scooter is not in freewheel mode.
2. Elevate the side of the Travel Scooter of which you are removing the tyre. Place wooden blocks under the frame to elevate the Travel Scooter.
3. Remove the drive wheel nut and washer from the axle. See figure 28.
4. Pull the wheel off the axle.
5. Slide the new wheel onto the axle. Make sure the the axle key is in the axle slot.

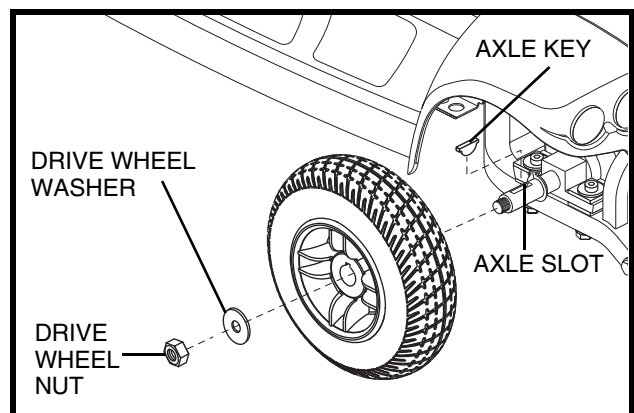

Figure 28. Wheel Replacement



WARNING! Failure to ensure that the axle key is properly installed into the axle slot when mounting the wheel can result in electronic brake failure, personal injury, and/or product damage.

6. Reinstall the drive wheel nut and washer onto the axle and tighten.



WARNING! Make sure that both the nut and washer are reinstalled and tightened properly.

7. Remove the blocks from beneath the Travel Scooter.

IX. CARE AND MAINTENANCE

EXTERIOR SURFACES

Bumpers, tyres and trim can benefit from an occasional application of a rubber or vinyl conditioner.



WARNING! Do not use a rubber or vinyl conditioner on the Travel Scooter's vinyl seat or tyre tread. They will become dangerously slippery.

CLEANING AND DISINFECTION

- Use a damp cloth and mild, non-abrasive cleanser to clean the plastic and metal parts of your Travel Scooter. Avoid using products that may scratch the surface of your Travel Scooter.
- If necessary, clean your product with an approved disinfectant. Make sure the disinfectant is safe for use on your product before application.



WARNING! Follow all safety instructions for the proper use of the disinfectant and/or cleaning agent before applying it to your product. Failure to comply may result in skin irritation or premature deterioration of upholstery and/or Travel Scooter finishes.

BATTERY TERMINAL CONNECTIONS

Make certain that the terminal connections remain tight and are not corroded.

WIRING HARNESSSES

- Regularly check all wiring connections.
- Regularly check all wiring insulation, including the charger power lead, for wear or damage.
- Have your authorised Pride Dealer repair or replace any damaged connector, connection or insulation that you find before using your Travel Scooter again.



PROHIBITED! Even though the Travel Scooter has passed the necessary testing requirements for ingress of liquids, you should keep electrical connections away from sources of dampness, including direct exposure to water or bodily fluids and incontinence. Check electrical components frequently for signs of corrosion and replace as necessary.

ABS PLASTIC SHROUDS

The shroud pieces are formed from durable ABS plastic and are coated with an advanced formula urethane paint. A light application of car wax will help the shrouds retain their high gloss.

AXLE BEARINGS AND THE MOTOR/TRANSAXLE ASSEMBLY

These items are all prelubricated, sealed, and require no subsequent lubrication.

MOTOR BRUSHES

The motor brushes are housed inside of the motor/transaxle assembly. They should be inspected periodically for wear by your authorised Pride Dealer.

CONSOLE, CHARGER AND REAR ELECTRONICS

- Keep these areas free of moisture.
- Allow these areas to dry thoroughly if they have been exposed to moisture before operating your Travel Scooter again.

NYLON LOCK NUT REPLACEMENT

Any nylon insert lock nut removed during the periodic maintenance, assembly or disassembly of the Travel Scooter must be replaced with a new nut. Nylon insert lock nuts should not be reused as it may cause damage to the nylon insert, resulting in a less secure fit. Replacement nylon insert lock nuts are available at local hardware stores or through your authorised Pride Dealer.

IX. CARE AND MAINTENANCE

STORING YOUR TRAVEL SCOOTER

If you plan on not using your Travel Scooter for an extended period of time, it is best to:

1. Fully charge its batteries prior to storage.
2. Remove the battery pack from the Travel Scooter.
3. Store your Travel Scooter in a warm, dry environment.
4. Avoid storing your Travel Scooter where it will be exposed to temperature extremes.

Batteries that are regularly and deeply discharged, infrequently charged, stored in extreme temperatures or stored without a full charge may be permanently damaged, causing unreliable performance and limited service life. It is recommended that you charge the Travel Scooter batteries periodically throughout periods of prolonged storage to ensure proper performance.



WARNING! Always protect batteries from freezing temperatures and never charge a frozen battery. Charging a frozen battery can result in damage to the battery.

For prolonged storage, you may wish to place several boards under the frame of your Travel Scooter to raise it off of the ground. This takes the weight off the tyres and reduces the possibility of flat spots developing on the areas of the tyres contacting the ground.

DISPOSAL OF YOUR SCOOTER

Your Travel Scooter must be disposed of according to applicable local and national statutory regulations. Contact your local waste disposal agency or authorised Pride Dealer for information on proper disposal of packaging, metal frame components, plastic components, electronics, batteries, neoprene, silicone and polyurethane materials.

X. WARRANTY

LIFETIME WARRANTY

Structural frame components, including: platform, fork, seat post and frame welds.

TWO-YEAR LIMITED WARRANTY

Drivetrain, including: transaxle, motor and brake.

ONE-YEAR LIMITED WARRANTY

All electrical parts, including controllers and battery chargers, are covered for one year under warranty. Any attempt to open or dismantle these parts will lead to this warranty being void.

BATTERIES

Batteries are covered by a twelve-month warranty from the original manufacturer.

NOT COVERED UNDER WARRANTY

The following are classed as wear items, which may, under normal wear and tear, require replacing. These items are not therefore covered under warranty: tyres, lap belts, bulbs, upholstery, plastic shrouds, motor brushes and fuses. Warranty will also be refused if damage is deemed to have been caused through misuse or accident for which Pride Mobility Products cannot be deemed responsible.

NOTE: Pride Mobility Products provides parts only under warranty. Your authorised Pride Dealer is responsible for labour and service. Please contact your authorised Pride Dealer for information about these services and for any applicable charges.

NOTES

NOTES



Pride[®]
Mobility Products Ltd.

*32 Wedgwood Road
Bicester, Oxon OX26 4UL*

www.pridemobility.com

* I NFMANU4194 *