

USER MANUAL

# TROPHY 20

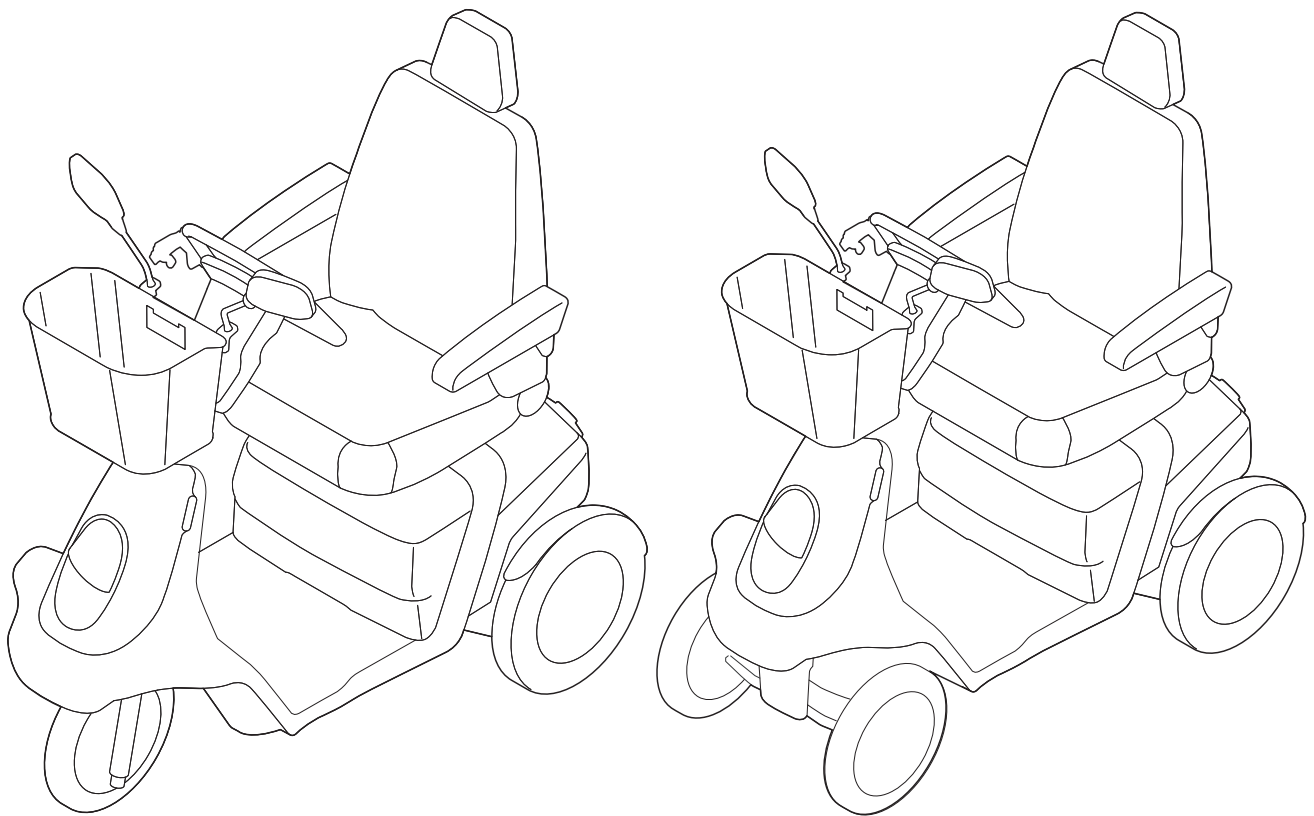

CE

 **handicare**

9006140B

---

---

# English

© 2011 Handicare

All rights reserved.

The information provided herein may not be reproduced and/or published in any form, by print, photoprint, microfilm or any other means whatsoever (electronically or mechanically) without the prior written authorization of Handicare.

The information provided is based on general data concerning the construction known at the time of the publication of this manual. Handicare executes a policy of continuous improvement and reserves the right to changes and modifications.

The information provided is valid for the product in its standard version. Handicare can therefore not be held liable for any damage resulting from specifications of the product deviating from the standard configuration. Illustrations contained in the manual may deviate from the configuration of your product.

The information made available has been prepared with all possible diligence, but Handicare cannot be held liable for any errors contained in the information or the consequences thereof.

Handicare accepts no liability for loss resulting from work executed by third parties.

Names, trade names, trademarks etc. used by Handicare may not, as per the legislation concerning the protection of trade names, be considered as being available.

2011-01

1	Introduction	6
1.1	This user manual	6
1.2	Symbols used in this manual	6
2	Safety	7
2.1	Temperature	7
2.2	Electromagnetic radiation and interference	7
2.3	Markings on the scooter	8
2.4	Technical specifications	9
2.5	Adaptations	9
2.6	General usage safety regulations	9
3	General description	11
3.1	Main components	12
3.2	The user	12
3.3	Intended use (1)	13
3.4	Adjustment options	13
4	Scooter settings	14
4.1	Adjusting the seat	14
4.2	Adjusting lumbar-support (if applicable)	15
4.3	Adjusting the steering column	15
4.4	Adjusting the rear suspension	16
4.5	Adjusting basket combination lock (if applicable)	16
5	Use of the scooter	17
5.1	Charging the batteries	17
5.2	Checks before use	17
5.3	Getting in and out (transfer)	18
5.4	Controls	18
5.5	Driving the scooter	23
5.6	Pushing the scooter	28
5.7	Dismantling the scooter for storage and/or transportation	30
5.8	Transporting the scooter	31
5.9	Storage after use	32
6	Maintenance	33
6.1	Maintenance table	33
6.2	Batteries	33
6.3	Tyres	34
6.4	Cleaning the scooter	34
6.5	Used scooters and the environment	35
7	Troubleshooting	36
7.1	Troubleshooting table	36
8	Technical specifications	37
8.1	CE declaration	37
8.2	Trophy 20 product specifications	37

---

9	Warranty	39
9.1	Provisions of warranty	39
9.2	Liability provisions	40
10	Maintenance and inspection record	41
11	Authorised service and technical support	43

# 1 Introduction

Congratulations on choosing a Handicare scooter. Handicare's high-quality mobility products are designed to enhance independence and make your everyday life easier.

## 1.1 This user manual

This user manual will help you to use and maintain your scooter safely. This entire user manual for this scooter consists of two booklets:

- The general wheelchair user manual (this booklet)
- The user manual for the battery charger

When necessary this general user manual refers to the manual of the battery charger as shown below:

 Battery charger

**Read this entire user manual (both booklets) carefully before using the product.** If one of the user manuals was not included with your scooter, please contact your dealer immediately.

In addition to this user manual, there is also a service manual for qualified specialists.

CONTACT HANDICARE IF YOU HAVE A VISUAL IMPAIRMENT.

## 1.2 Symbols used in this manual

---

### **Note!**

*Pointing out possible problems to the user.*

---

### **Caution!**

*Advice for the user to prevent damage to the product.*

---

### **Warning!**

*Warnings for the user to prevent personal injury.*

---

Not following these instructions may result in physical injury, damage to the product or damage to the environment!

## 2 Safety

Handicare accepts no liability for loss or injury caused by not following the safety rules and regulations fully, or otherwise for loss or injury as a result of negligence during use or when cleaning the scooter and any accessories. Supplementary safety regulations may apply depending on the specific circumstances for operation or on the accessories used. Please contact your dealer immediately if you should ascertain any potential hazards when using the product.

### 2.1 Temperature

#### **Warning!**

*Avoid physical contact with the scooter's motor. The motor is continuously in motion during use and can reach high temperatures. After use, the motor will cool down slowly. Physical contact may cause burns.*

*Ensure that the scooter is not exposed to direct sunlight for extended periods of time. Certain parts of the scooter, such as the seat, the backrest, the armrests and the steering device become hot if exposed to the sun for too long. This may cause burns or skin irritation.*

### 2.2 Electromagnetic radiation and interference

The scooter has been tested for compliance with the applicable requirements regarding electromagnetic radiation (EMC requirements). The Trophy 20's immunity level is 20 volt/metre.

#### **Note!**

*It cannot be excluded that electromagnetic radiation emanating from mobile telephones, medical apparatus and other sources, may have an influence on the scooter.*

*It cannot be excluded that the scooter will interfere with the electromagnetic fields of, for example, shop doors, burglar alarm systems and/or garage door openers.*

In the unlikely event that such problems do occur, you are requested to notify your dealer immediately.

Powered wheelchairs and scooters can be affected by sources of radio waves, such as radio and TV transmitters, amateur radio stations, lifts, transmitting equipment, stereo radios and mobile telephones. If the scooter's electronics are not well shielded, sensitive electrical devices, such as shop alarm systems and garage door openers, can be affected. The scooter has been tested for such interference. Please report any problems of this nature to your dealer immediately.

The following advices are intended to prevent the electric scooter from being driven unintentionally, which could lead to serious injury.

1. Do not turn on any manually controlled equipment for personal communication, such as a radio transmitter or mobile telephone, while the electric scooter is switched on.
2. Keep at a distance from transmitter equipment, such as radio and TV stations.
3. If the scooter starts making unintended movements, or if the brake goes into freewheel / neutral mode, turn off the powered wheelchair or scooter by removing the ignition key from the lock.
4. Be aware of the fact that any accessories, components or adaptations installed on the scooter may increase the effect of radio waves.

#### **Note:**

*There is no easy way of testing the effects of radio waves on the general immunity of powered wheelchairs or scooters.*

5. All cases of unintended movements of the scooter spontaneously going into freewheel / neutral mode should be reported to your dealer or to the scooter manufacturer. When reporting, please indicate whether a source of radio waves was nearby at the time.

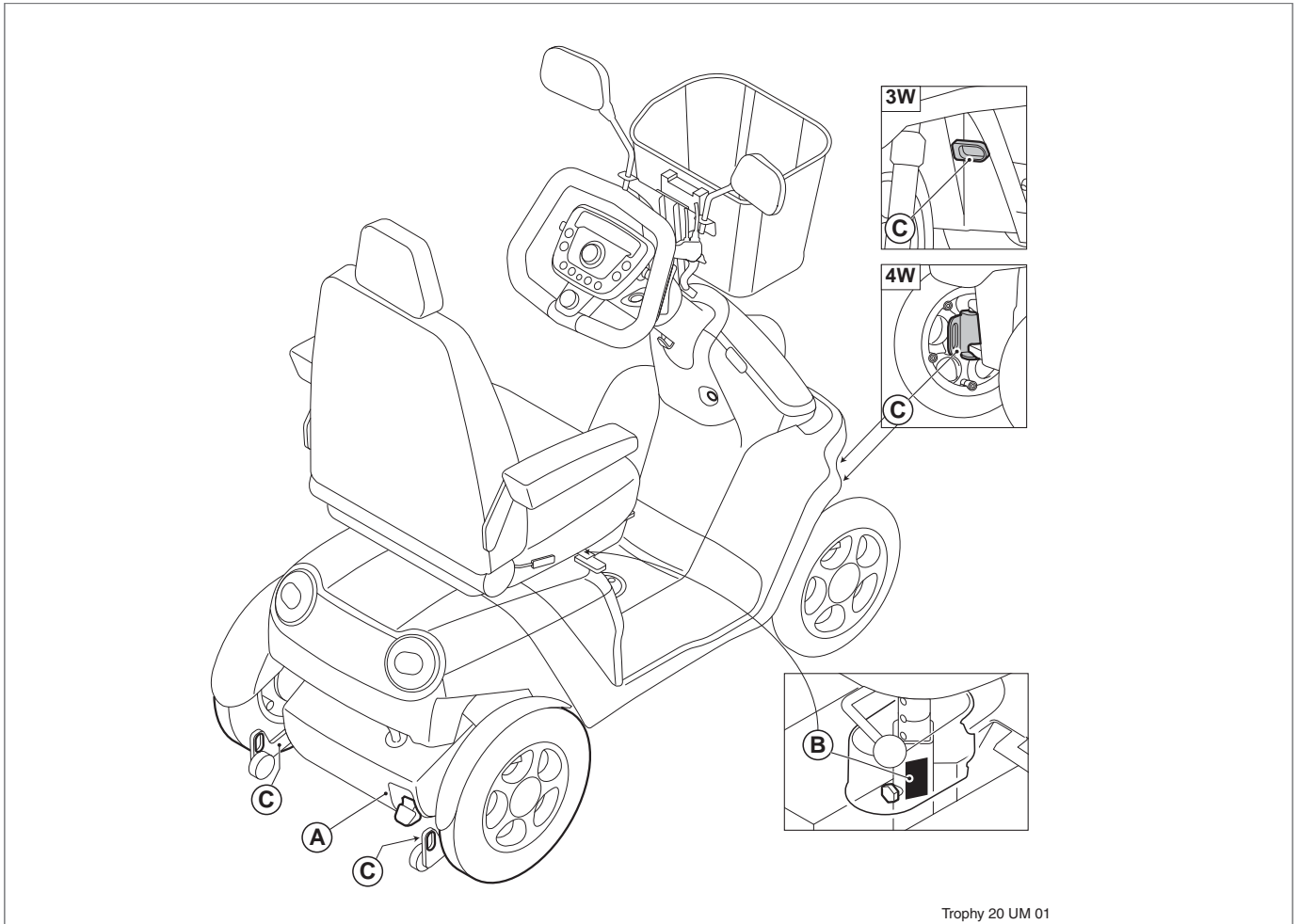

Trophy 20 UM 01

## 2.3 Markings on the scooter

Never remove or cover up the markings, symbols and instructions affixed to the scooter. These safety measures must remain present and clearly legible throughout the entire lifespan of the scooter.

Replace or repair any markings, symbols or instructions that have become illegible or damaged immediately. Please contact your dealer for assistance.

### Product labels

The following sticker/label can be found on the product:

- A. Freewheel handle position
- B. Product ID
- C. Instruction for transportation

- A. Freewheel handle position
  1. DRIVE mode: Lever fully upper position: Motor brake applied, scooter can not be pushed
  2. FREEWHEEL / NEUTRAL mode: Lever lowest position: Motor brake not applied. Scooter can be pushed manually when electronics are off.
- B. Identification plate
  - A. Model
  - B. Date of manufacture
  - C. Serial number
  - D. Usage: indoor, outdoor or both
  - E. Maximum load in kg
  - F. Manufactures address
- C. Instruction for transportation (see 5.8)

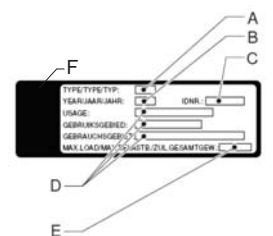

### **Warning!**

*Scooter is not intended to be used as seat in motor vehicle*



## 2.4 Technical specifications

No changes may be made to the technical specifications.

## 2.5 Adaptations

Adaptations to components of this product are not permitted

## 2.6 General usage safety regulations

It is of great importance that attention be paid to the following safety regulations for the prevention of accidents and undesirable situations.

### **Warning!**

*Take extra care when driving on slopes:*

*Never remove safety devices, such as the anti-tip wheels.*

*Never drive the Trophy 20 up slopes with a gradient greater than that specified in section 5.6 of this manual.*

*Always drive up slopes slowly and take extra care.*

*Never descend a slope at full speed.*

*Do not drive down slopes covered with loose gravel or with a sandy surface, as one of the back wheels may slip.*

*Do not turn on slopes.*

*When driving up a slope, adopt a position which promotes stability, as described in section 5.6 of this manual.*

*Never take corners at full speed. Reduce speed before taking a corner.*

*Ensure that clothing does not trail as this can become entangled in the wheels.*

*Ensure that your fingers do not become trapped in the mechanism for adjusting the position of the steering column.*

*You must adjust your driving to the prevailing conditions:*

*Drive carefully on roads which have become slippery due to rain, black ice or snow!*

*Reduce speed in busy surroundings.*

*Do not use the scooter on unsurfaced roads.*

*Ensure that the Trophy 20 does not come into contact with salt water. Salt water is corrosive and can damage the scooter.*

*Ensure that the Trophy 20 does not come into contact with sand. Sand can find its way into the moving parts of the scooter, resulting in these parts wearing out unnecessarily quickly.*

*Never drive the scooter while under the influence of drugs, alcohol or prescription medications which could affect your driving ability.*

*Your eyesight must be adequate for you to drive the scooter safely.*

*If visibility is not ideal, then it is obligatory for the lights to be turned on. The scooter is equipped with brake lights which illuminate on braking.*

*Use the indicator lights only to indicate a change in driving direction.*

*Only use the horn for warning pedestrians or other road users of possibly hazardous situations.*

*Never place metal components on top of the batteries. Doing so could cause a short circuit, leading to damage.*

*Do not transport any passengers on the scooter. The scooter has been specifically designed to transport you alone.*

*Do not drive the scooter with the seat backrest angled too far to the rear. This can affect weight distribution and the stability to the rear of the scooter, in particular when driving up slopes or over obstacles.*

*Ensure that your scooter does not transport a greater load than fits in the basket or heavier than 5 kg.*

*Never use the scooter for pulling a trailer. The scooter has not been designed for such use and doing so can cause serious damage to your scooter.*

*Do not stand on the platform in order to reach up to objects.*

*Do not position your feet too close to the front wheel and fork when driving.*

*The scooter is electronically driven. Specific parameters have been factory-set. These settings have been made in order to ensure that use of the Trophy 20 is comfortable and efficient and they cannot be changed.*

*Never sit on a scooter when it is in the freewheel / neutral mode.*

*Never sit on a scooter when you are transferred by a taxi, car or by public transportation.*

*Beware of ultraviolet light. Ultraviolet light can cause premature wear of materials such as rubber, plastic and enamel.*

*Pay attention to objects sticking out from the scooter. These can cause damage to your surroundings or to the scooter itself.*

*Keep the scooter away from open flames.*

*Avoid extreme weather conditions or extremely wet conditions. Maintain and store the scooter in a clean and dry state.*

*If you use a mobile telephone near to a specially adapted scooter, it is advisable to switch the scooter off first.*

---

### 3 General description

The Trophy 20 scooter is intended to operate in an indoor/outdoor environment. The scooter is sufficiently compact and manoeuvrable for some indoor environments and capable of negotiating some outdoor obstacles. The Trophy 20 is therefore classified according to European requirements EN12184 as a class B scooter.

The Trophy 20 scooter is available in a 3 wheel and 4 wheel version.

The seat height can be adjusted to the length of the user's legs. The scooter's seat can be swivelled and the armrests can be folded away to facilitate sitting down on the scooter or getting up from the scooter.

The steering column is adjustable for a comfortable driving position.

Extra caution must be paid when driving at higher speeds. Pay attention to your speed and slow down, particularly on pavements and in pedestrian areas.

The following points should always be remembered when using the scooter:

- Pay careful attention when driving on public roads. Always follow the local terms of traffic regulations.
- You are always responsible for your scooter being in perfect working order so that the scooter can be driven safely.
- The scooter is a technical product. For this reason it is important that repairs and all maintenance are carried out by qualified personnel. If your scooter needs attention, then you must contact your dealer.

The freewheel handle at the back of the Trophy 20 is intended to be used by attendants only. The freewheel / neutral mode shall only be used when the scooter is unoccupied.

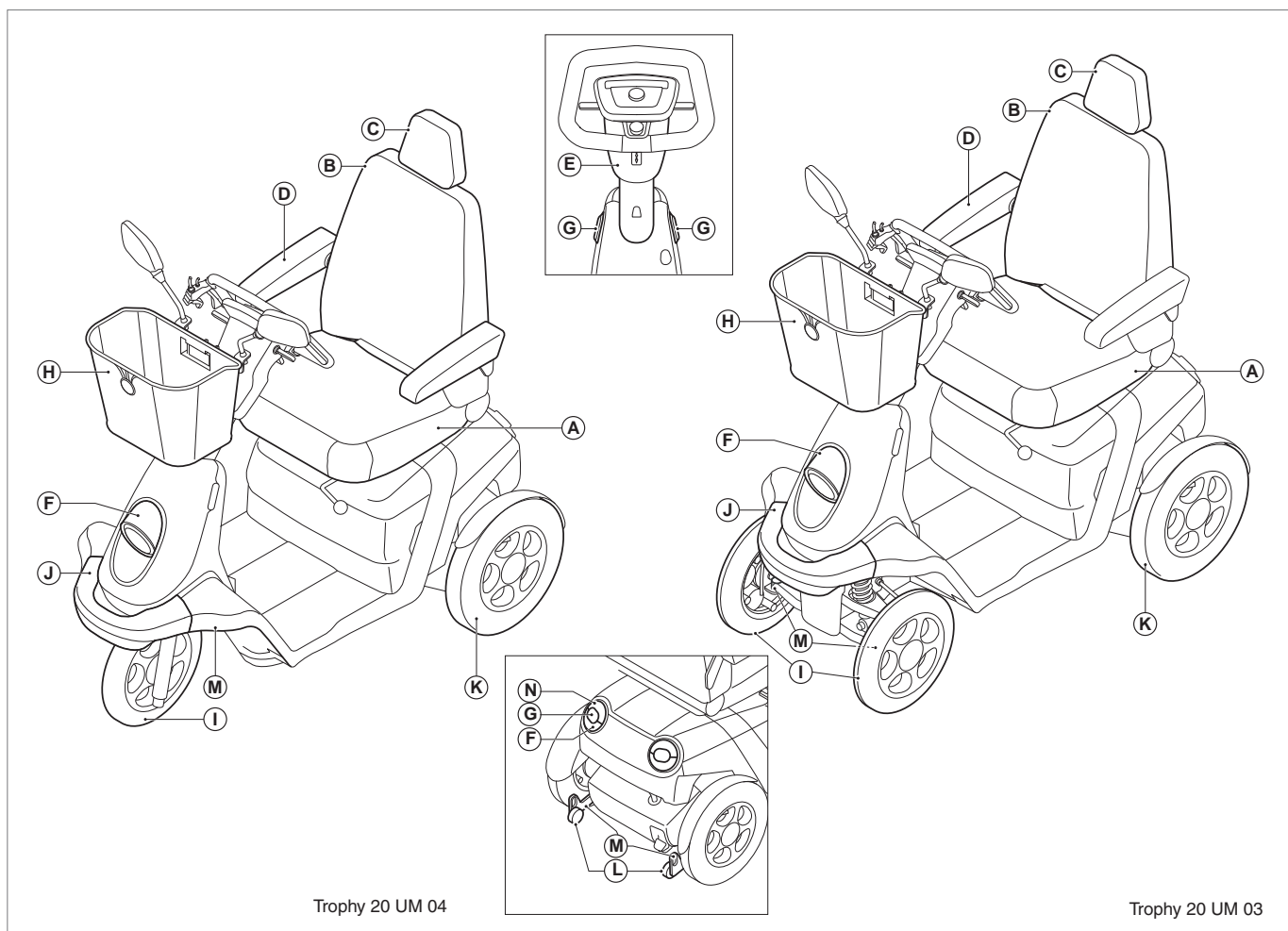

Trophy 20 UM 04

Trophy 20 UM 03

### 3.1 Main components

The scooter is equipped with, or can be equipped with, the following main components:

- A. Seat: this is where the user sits
- B. Backrest: supports the user's back
- C. Headrest: supports the head
- D. Armrest: supports the arms
- E. Steering column: the control panel and all of the control keys and levers are located on the steering column
- F. Lights: the lights should be switched on when driving in the dark
- G. Indicator lights: indicate changes in direction while driving
- H. Detachable basket: for the transportation of personal belongings
- I. Front wheel: front wheel with suspension
- J. Front bumper: protects the front wheel on collision
- K. Rear wheels: rear wheels with suspension
- L. Anti-tip wheels: wheels to prevent the scooter from tipping over backwards on slopes

M. Attachment points: points of attachment for securing the scooter

N. Brake lights: automatic activated when braking

Various elements and components on the scooter can be adjusted for optimal seating comfort.

### 3.2 The user

The dealer must give you clear instructions before you start operating the product independently.

Your first test drives of the Trophy 20 are best carried out under the supervision of an experienced dealer.

The Trophy 20 has a maximum speed of 12 km/h (country specific).



#### **Warning:**

*Ensure that you are fully acquainted with the contents of this manual before starting to drive the Trophy 20*

If you use the scooter in a dangerous fashion, or use the scooter for purposes other than those intended, Handicare will accept no liability for any personal injury or damage to property caused by such misuse.

### **Warning!**

*The user of the scooter (see 'Intended use') is at all times responsible for following local safety rules and guidelines.*

*Driving the scooter under the influence of medicines that can affect your ability to drive is not permitted.*

*Driving the scooter without sufficient eyesight is not permitted.*

*No more than one person is to be seated in the scooter at a time.*

*Do not allow children to ride in the scooter unsupervised.*

### **3.3 Intended use <sup>(1)</sup>**

The Trophy 20 scooter was developed for:

- The transportation of one people weighing up to 130 kg (and optional up to 160 kg)
- Use on pavements, footpaths, cycle paths and roads (if allowed by country traffic rules)
- Use in and around the house
- The Trophy 20 is capable driving outdoors at night.
- The scooter is not intended for sports of very heavy outdoor activities.
- The scooter is not intended for use as seat for transport in a motor vehicle.
- The scooter is not designed for children.
- The scooter is not intended to pull loads
- The scooter is not intended to carry more than one person.
- The scooter is not intended to for user weights above 160 kg.

Usage temperature	-25 °	+85 °
Relative humidity	0 %	98 %
Storage environment temperature	-40 °	+85 °
Relative humidity	0 %	98 %

(1) Intended use, as specified by EN 292-1, means the use for which the technical product is suitable according to the manufacturer's declaration, including the manufacturer's instructions in the sales brochure. In the event of doubt, use is taken to mean the use as construed from the design, construction and function of a product. The instructions contained in the user manual must also be followed within the scope of intended use.

### **3.4 Adjustment options**

There are a number of adjustments which can be made to the Trophy 20 in order to improve its seating and driving comfort levels.

Some adjustments are permanent adjustments made by the dealer using tools.

Other adjustments can be made by the user without the use of tools.

Adjustments that can be made by your dealer:

- Seat height
- Steering column length
- Rear suspension

Adjustments that can be made by the user:

- Seating position
- Armrest position
- Steering column height

## 4 Scooter settings

### 4.1 Adjusting the seat

#### Adjusting the seat height (figure 1)

The entire seat can be adjusted in height in order to obtain the optimal seating position. This adjustment is carried out by the dealer.

#### Adjusting the seat depth (sliding system) (figure 2) (seat may vary from the illustration)

The seat depth can be adjusted as follows:

- Lift and hold handle (A).
- Slide the seat forwards or backwards.
- Release the handle once the seat is in the required position. Now slide the seat slightly forwards or backwards so that it locks into place.
- The seat depth has now been adjusted..

#### Adjusting the backrest (figure 3)

The backrest angle can be adjusted as follows:

- Lift handle (A) whilst sitting on the seat. The backrest now automatically moves forwards.
- Push the backrest to the rear by leaning against it until it is in the position you find the most comfortable.
- Once adjusted, release the handle. The backrest remains in the position you selected.

#### **Warning!**

*Exercise caution when using the handle when no one is sitting on the seat. The backrest is equipped with a spring mechanism which causes it to be driven quickly forwards with some force.*

*The backrest can be adjusted to provide good back support while driving. If the backrest is adjusted to an angle too far to the rear, the driver's seating position is then less stable, particularly on slopes. It is therefore important never to drive your scooter if the backrest is inclined too far back.*

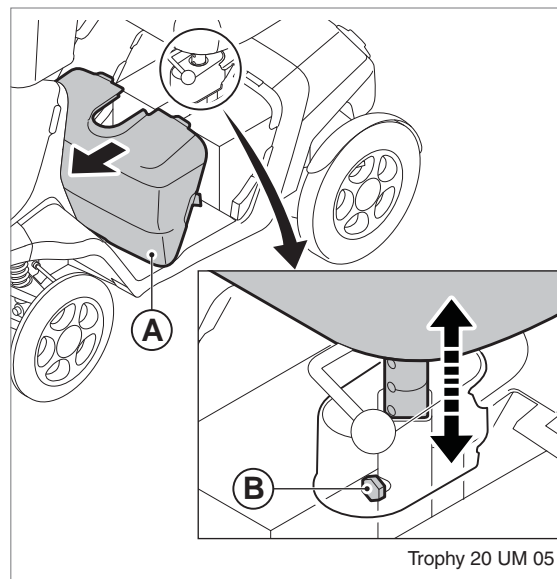

Figure 1

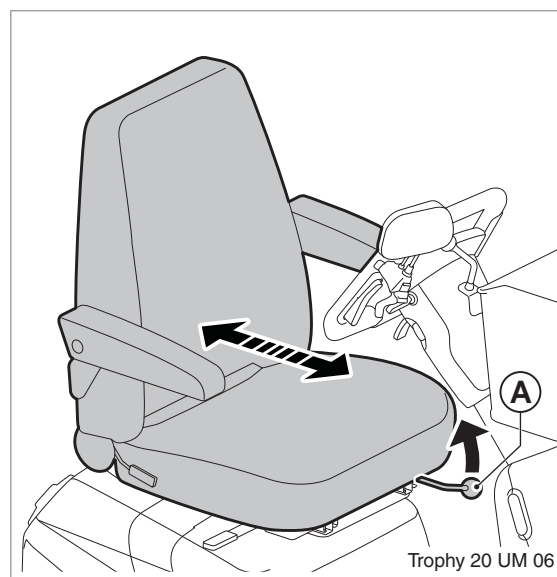

Figure 2



Figure 3

### Adjusting the armrest (figure 4)

The armrests can be adjusted as follows:

- The rotary knobs (A) for adjusting the height of the armrests are located on the bottom side the armrests.

### Adjusting the headrest (if applicable)

The headrest can be adjusted to various heights.

The headrest height is adjusted as follows:

- Press the plastic button at the point where the headrest is attached to the seat, at the same time moving the headrest to the required height. The headrest can also be removed if required.
- Release the button and move the headrest slightly so that it locks into one of the positions.

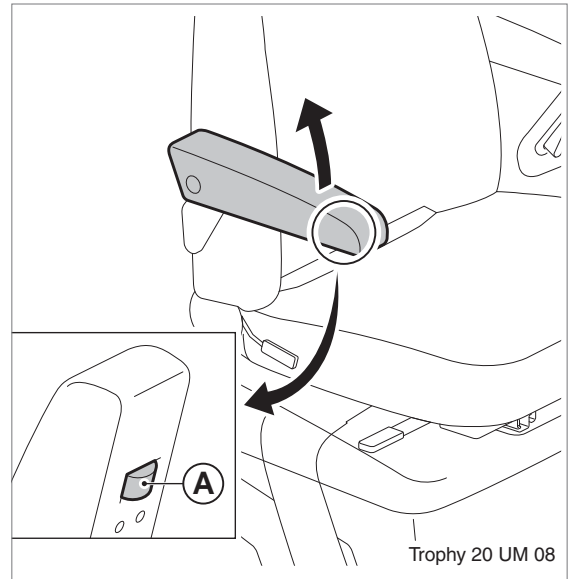

Figure 4

## 4.2 Adjusting lumbar-support (if applicable)

The lumbar-support can be adjusted by turning knob A to achieve the most comfortable position (figure 5).

## 4.3 Adjusting the steering column

The steering column can be adjusted to make driving more comfortable and to make it easier for you to mount and dismount from the scooter (figure 6).

Steering column length can be adjusted by dealer as follows:

- Untighten the screw (A) with allen-key (5 mm)
- Adjust the length (a-direction)
- Tighten screw A

The steering column is adjusted by user as follows:

- Using one hand, pull handle (B) upwards while pulling the steering column towards you with the other hand until it is in the most comfortable position.
- Release the handle. Then release the steering column.

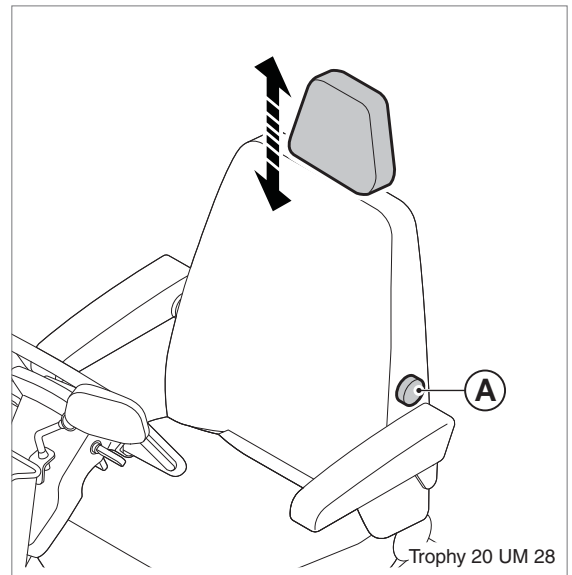

Figure 5

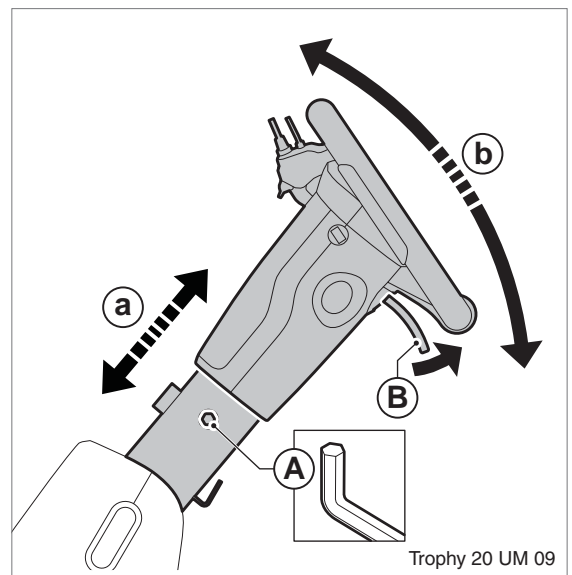

Figure 6

### **Warning!**

Exercise caution while adjusting the steering column and ensure that your fingers do not become trapped.

## 4.4 Adjusting the rear suspension

The rear suspension of the scooter can be adjusted to provide optimal comfort. This adjustment is carried out by the dealer.

## 4.5 Adjusting basket combination lock (if applicable)

The code is set to 0-0-0 ex-works.

### Adjusting the code (figure 7)

1. Remove the button (1) using a small, sharp object.
2. Move the released button (2) in the direction of the wheels.
3. Keep the button in this position and set your personal code by turning the wheels.
4. Remember this code.
5. Release the button: your code has been set.
6. Firmly push the button (1) back in its position.
7. To unlock and release the basket, move the button to 'open'.

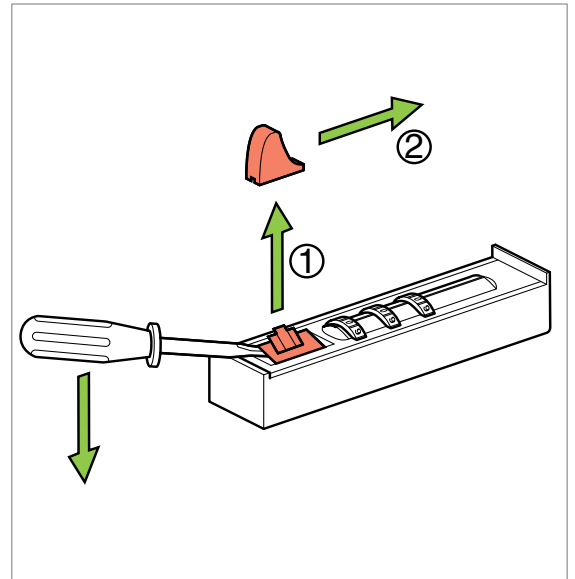



Figure 7

## 5 Use of the scooter

The following matters are covered in this manual in order to enable you to drive your scooter:

- Charging the batteries
- Checks before use
- Getting in and out (transfer)
- Controls
- Driving the scooter
- Pushing the scooter
- Dismantling for storage and/or transportation
- Transporting the scooter
- Storage after use

### 5.1 Charging the batteries

Consult the following documentation on charging the batteries: Regulations relating to batteries. The battery charger manual, or the instructions on the battery charger. ( Battery charger)

The scooter uses gel batteries which are fully encased and sealed and require no maintenance.

Under normal use the batteries need to be charged every night. Charge the batteries as follows:

- Switch off the scooter.
- Plug the charging cable into the charging point. See 'Charging point'.
- Plug the battery charger into the wall socket.
- Turn on the battery charger (if the battery charger has an on/off switch).

---

#### **Note!**

Use only maximum 8 A battery chargers.

---

Once the batteries are charged you must:

- Turn off the battery charger, if applicable.
- Unplug the battery charger from the wallsocket.
- Disconnect the charger from the charging point on the scooter.

The scooter is now ready for use.

---

#### **Note!**

Always remove the charging cable once the batteries have been charged. This prevents the batteries from slowly running down.

---

### Run-in batteries

For optimum battery performance, it is recommended that new batteries undergo 15 to 20 charge and discharge cycles, with a maximum of three days between each cycle. This can be done by recharging batteries only once they have been discharged to under 50%.

### 5.2 Checks before use

The following checks should be carried out each time before the scooter is used:

- Check whether the seat adjustments are locked in place.
- Check whether all lights and indicators, both front and rear, are in good working order.
- Check whether tyre pressures are correct. See 'Product specifications' (2.5 bar front, 3.5 bar rear).
- Tyres which are poorly inflated make driving more difficult and less pleasant.
- The scooter uses more power and the batteries run down more quickly if tyres are poorly inflated.
- Poorly inflated tyres cause the tyres to wear unnecessarily.
- Check whether the batteries are sufficiently charged: this is indicated by the green section of the battery indicator. See 'Control panel'

---

#### **Warning!**

*The capacity of the batteries is reduced in winter. When there is a light frost, battery capacity is reduced to approximately 75%, and when temperatures are under -5°C, capacity drops to around 50% of the normal capacity. This reduces the scooter's range.*

---

- Check whether the freewheel handle is in the drive mode. See chapter 5.7.
- Check whether the brakes are in good working order. See 'Driving the scooter'.

If the scooter does not react in a predictable fashion, immediately release the throttles and allow the scooter to come to a complete standstill. Remove the ignition key from the control panel and then re-insert it to restart the scooter. If there are no problems, then the scooter can be driven.

### 5.3 Getting in and out (transfer)

(seat may vary from the illustration)

#### **Warning!**

Before mounting or dismounting, ensure that the scooter is turned off by removing the ignition key. The automatic parking brake must also be applied..

The armrest can be lifted and the seat can be swivelled to the side before mounting or dismounting.

Mounting (figure 8):

- Push the seat lock handle (A) forwards and swivel the seat by a quarter of a turn to the left or to the right. When you release the seat lock handle the seat locks into place automatically. The handle clicks back into place by itself.
- You can now be seated.
- Swivel the seat back into place in the same way as described above.

When the seat is in the normal position again, it clicks into place automatically. This means that the seat can not start to swivel while driving.

The seat has folding armrests, allowing you to mount or dismount from the side. After mounting or dismounting, always check whether the armrests have been folded back down.

Before dismounting, follow the same steps but in reverse order.

### 5.4 Controls

The scooter has the following controls (figure 9)

- A. Control panel with all of the control keys
- B. Handle for adjusting the angle of the steering column
- C. Charging point. See 'Charging the batteries'.
- D. Forward or reverse levers
- E. Handles for indicator lights
- F. Ignition key
- G. Brake



Figure 8

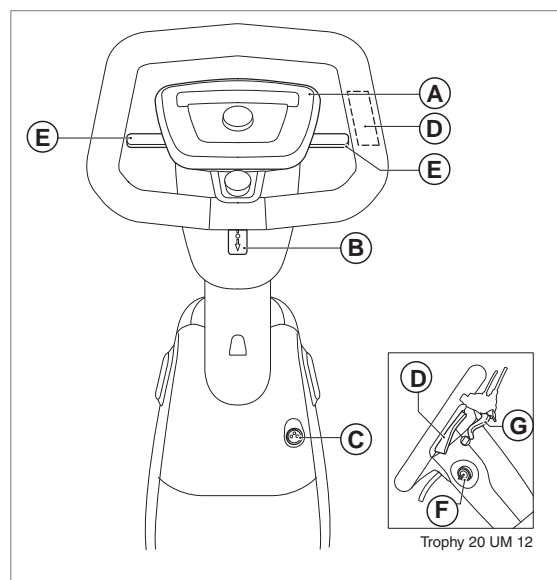
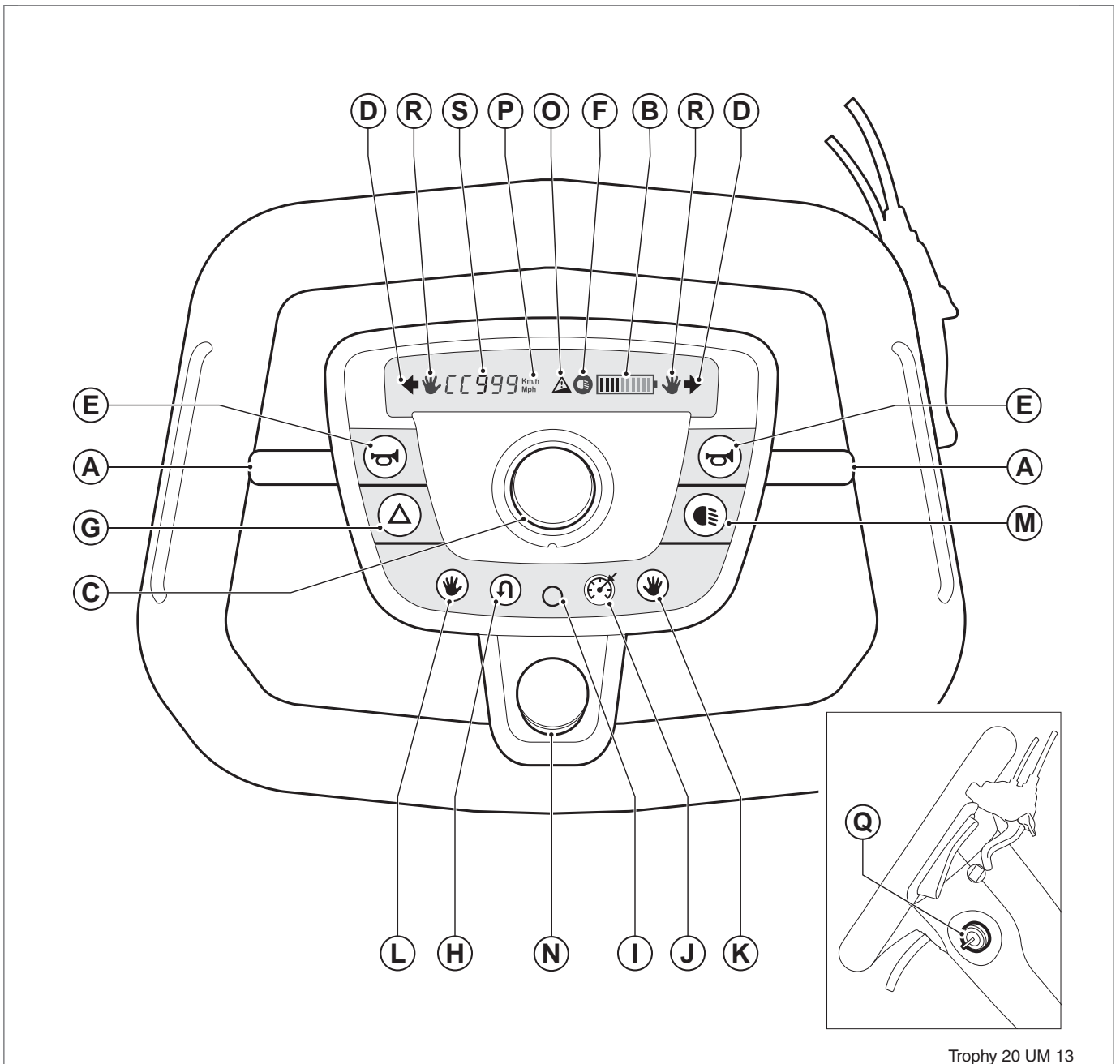

Figure 9









Trophy 20 UM 13





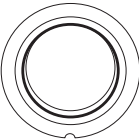



The control panel is equipped with the most advanced technology, offering functions for operating your scooter which are both useful and reliable.



- A. Indicator handles, left and right \*
- B. Battery indicator
- C. Speed regulator
- D. Indicator for hazard lights / indicator lights
- E. Horn switch\*
- F. Indicator for lights
- G. Hazard lights switch
- H. Reverse switch for foot throttle (if applicable)
- I. Display menu selection switch
- J. Cruise control switch (if applicable)
- K. Right throttle selection switch (if applicable)
- L. Left throttle selection switch (if applicable)

- M. Light switch
- N. Emergency stop button (if applicable)
- O. Safe slope alarm indicator
- P. Light sensor
- Q. Ignition key
- R. Active throttle indicator (if applicable)
- S. Display

\*These keys can be found on both the left-hand and right-hand side of the control panel.

	<p>A. Indicator handles, left / right</p> <p>On moving the handle (on the left or right-hand side) the indicator light starts flashing in order to indicate that you are going to change direction:</p> <ul style="list-style-type: none"> <li>• Move left handle downwards or right handle upwards for turning left</li> <li>• Move left handle upwards or right handle downwards for turning right.</li> </ul> <p>A bleeping sound can be heard when the indicator is switched on (if programmed). To turn off the indicators, press the same handle in the same direction again or wait 12 seconds.</p>
  	<p>B. Battery indicator</p> <p>The battery indicator provides a general indication of the state of the batteries. The batteries are fully charged when all the lights are illuminated. As the battery runs down, the lights go out one by one and changes into red, when it becomes critical. The indicator lights indicate the battery voltage available for the control unit. It is normal for the lower indicator to go out when the scooter accelerates. This is because extra power is needed momentarily, leading to a decrease in available voltage. This momentary dip is not a true indication of the battery capacity. When the scooter is used for the first time, the battery indicator may show that the batteries are fully charged, even if this is not the case. This is a feature of the batteries. Therefore, the most accurate indication of the battery level is to be obtained when driving on a flat surface.</p> <p>If the RE D lights are illuminated on the battery indicator, then it is important that the batteries be recharged as soon as possible. Ensure that the batteries never run down completely; this reduces the lifespan of the batteries and can damage them.</p> <p>When lights are continuously moving, it indicates that the batteries are charging. The battery indicator gives also error messages from the controller. Dealer can analyse with the help of this fault-code message, the problem.</p>
	<p>C. Speed regulator</p> <p>This knob allows you to set in 10 steps the desired maximum speed for your scooter. The maximum speed is increased by turning the knob in a clockwise direction. Turning the knob in an anti-clockwise direction decreases the maximum speed. Adjust the speed regulator before driving. Adjust the maximum speed to the surroundings and to traffic conditions (to a limited amount of space or to a room full of people, for example).</p>
	<p>D. Indicator for hazard lights / indicator lights</p>
	<p>E. Horn switch</p> <p>By pressing one of the horn keys, a warning sound is emitted to warn others of hazardous situations.</p> <p>The horn continues to sound as long as the key is pressed.</p>
	<p>F. Indicator for lights</p> <p>This indicator is activated when lights are switched on.</p>
	<p>G. Hazard lights switch</p> <p>Pressing this key turns on the hazard lights.</p> <p>The hazard lights should be used if you suspect that you will not be seen by other road users, or if the scooter is at a standstill due to a defect.</p> <p>Pressing this key once more turns off the hazard lights. A bleeping sound is emitted when the hazard lights are turned on (if programmed).</p>

	<p>H. Reverse switch for foot throttle (if applicable) Key to change direction when foot throttle is installed. After switching off the scooter by key, emergency stop, the standard direction is always forward.</p>
	<p>I. Display menu selection switch Key to switch between display menu showing speed, trip distance and overall distance. When holding this key for more than 2 seconds in trip/mode, this value will be reset.</p>
	<p>J. Cruise control switch (if applicable) Key to activate cruise control and set speed on current forward driving speed. Display will indicate CC when cruise control is set. It deactivates automatically when brake, emergency stop button, throttle, throttle selection switch, switch or CC-switch is used.</p>
	<p>K. Right throttle selection switch (if applicable) Key to select / activate manually the right throttle, when also other throttles are installed. This will also be indicated on display. This is always active after switching on the scooter.</p>
	<p>L. Left throttle selection switch (if applicable) Key to select / activate manually the left throttle, when also other throttles are installed. This will also be indicated on display.</p>
	<p>ITS Intelligent Throttle Switch (if applicable) After switching on the scooter, the first throttle that is used, becomes active. To switch to the other throttle, simply the other throttle should be operated and the currently active throttle should be released within 2 seconds. ITS is only possible in forward direction</p>
	<p>M. Light switch By pressing this key once, the front and rear lights are turned on. On pressing once more, the lights are turned off again.</p>
	<p>N. Emergency stop button (if applicable) Push to enable the emergency stop button. The scooter stops driving immediately and the hazard lights will turn on. To disable this function, the button needs to be turned counter clockwise and switch the scooter off and on again.</p>
	<p>O. Safe slope alarm indicator This indicator lights up when a slope is too steep and exceeds the safe slope specification. Advice is stop driving further on this slope due to safety and drive back very carefully as mentioned in section 5.6.</p>
	<p>P. Light sensor This sensor controls the brightness of the display automatically. Daylight → bright. Darkness → dimmed.</p>
	<p>Q. Ignition key The ignition key needs to be inserted in the ignition lock and turned in order to switch on the scooter. All of the Trophy 20 functions can be operated only when the ignition key has been inserted in the ignition lock, with the exception of the lights and the hazard lights. The hazard lights and lights can always be operated, even when the ignition key has not been inserted in the lock. If the ignition key is inserted in the lock and the scooter is not used for a period of time, a beeping sound is emitted after 20 minutes.</p>

	<p>R. Active throttle indicator (if applicable) Indicates, when more than one throttle is installed, which throttle is active. In case just one throttle system is installed or foot throttle is active, indicators will be activated.</p>
	<p>S. Display Display shows user info like speed, trip distance in a resolution of 0.1 km or M and overall distance in a resolution of 1 km or M. It also indicates the units (km/h or Mph) and if the cruise control is activated by showing CC. Flashing values means that the reverse direction is active for foot throttle. The brightness of the display will automatically change to its environment</p>

### Switching on

The scooter is switched ON as follows (figure 10):

- Insert the ignition key as far as possible in the lock (A) and turn it clock-wise towards the 1 indicating the switched ON position.

The scooter is switched OFF as follows (figure 10):

- Turn the ignition key as far as possible counter clock-wise towards the 0 indicating the switched OFF position. Remove the key from the lock (A).

### Charging point

- The charging point (A) is located on the steering column, under the control panel (figure 11). This is the point to which the battery charger cable can be connected.

All electronics must be switched off while the batteries are charging. Remove the ignition key before charging the batteries.

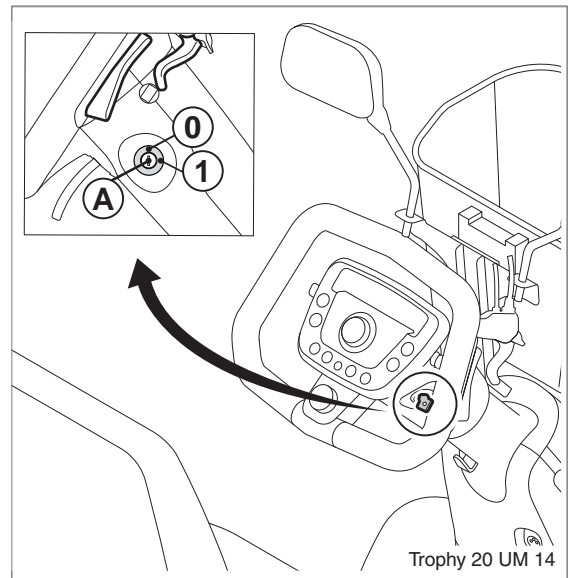

Figure 10

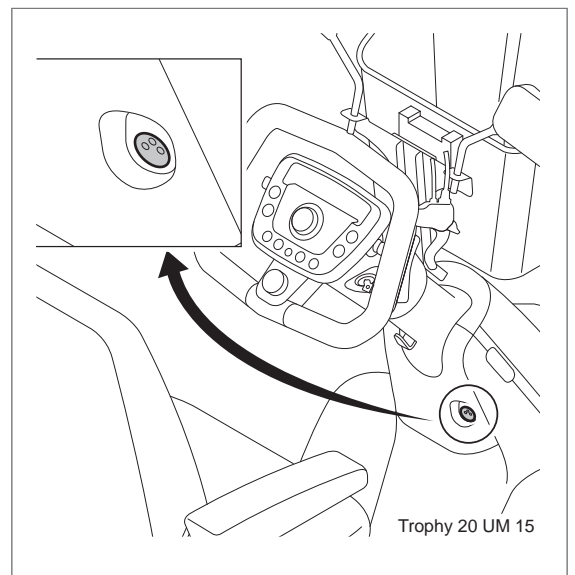

Figure 11

## 5.5 Driving the scooter

The scooter needs to be adjusted to your personal needs before you begin driving it. After carrying out all of the checks, take your seat on the scooter. See 'Mounting and dismounting'. You can now begin driving. As the driver of the scooter, it is important to remember that other people may not always notice you. Always pay sufficient attention to the people and traffic around you.

### Forward drive and reverse drive (figure 12)

Forward drive with finger control:

- Switch the scooter on. See 'Switching on'
- Pull the lower part of the throttle slowly with your fingers. The further you pull, the faster you will drive.

Reverse drive with finger control:

- Switch the scooter on. See 'Switching on'
- Pull the upper part of the throttle slowly with your fingers. The further you pull, the faster you will drive.

Driving with foot throttle (figure 13):

- Switch the scooter on (see switching on).
- The scooter always starts up in forward direction.
- Push the foot throttle slowly. The further you push, the faster you drive.
- For reverse direction simply push the reverse direction key. Now the values in the display will be flashing.
- Press this key again to select forward direction.

### Automatically forward driving (If applicable)

Through cruise control the scooter can drive automatically. When the cruise control button is pressed, the scooter will continue driving the current speed. The cruise control will automatically switch off when the reverse switch, cruise control switch, right or left throttle switch, emergency stop, brake or throttle button is pressed.

### **Warning!**

*Check to see that the space behind you is free before driving in reverse.*

*The maximum speed for driving in reverse is half the maximum speed for forward drive.*

The speed regulator allows you to limit the maximum speed in 10 steps for both forward and reverse drive.

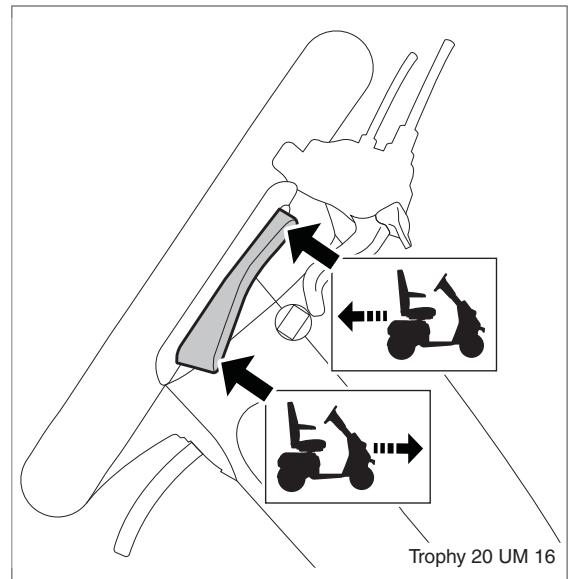

Figure 12

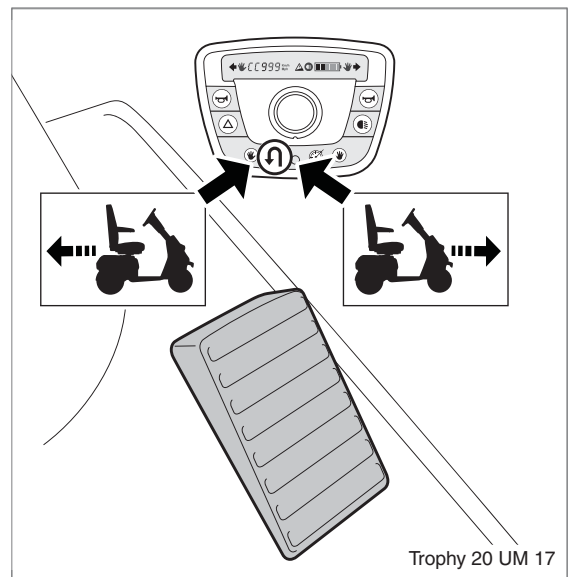

Figure 13

### Braking and stopping when in forward or reverse drive (figure 14)

- On slowly releasing the throttle, the Trophy 20 brakes and comes to a standstill.
- On braking, the lights and brake lights illuminate automatically.
- If you need to stop suddenly while driving, the throttle should be immediately released and/or the manual brake can be used.
- Once the scooter has come to a standstill, the parking brake is automatically applied.
- As extra security, the manual brake is equipped with an additional parking brake feature. This should also be used when the scooter is in freewheel / neutral mode. See section 5.7.
- In case of emergency the optional emergency stop button can be pushed. The scooter will make an emergency stop (figure 15). After using the emergency stop button, it needs to be pulled back by turning it clockwise (as indicated on the emergency stop button) and the ignition key needs to be turned off and on again to proceed driving.

#### Note!

The brakes can be checked by releasing the drive lever suddenly.

When driving at high speeds caution must be exercised, particularly on pavements and in pedestrian areas. In such cases it is advisable to set a lower maximum speed using the speed regulator.

Do not cross over any roads until you can handle the scooter and the controls.

#### Corners

Going around corners; Turning left or right

- If you turn the tiller to the left or to the right, the scooter changes direction and will drive to the left or to the right.

#### ⚠ Warning!

When turning, always remember to make a visual check first and to use the indicators.

Always take corners at a safe speed, i.e. at a reduced speed.

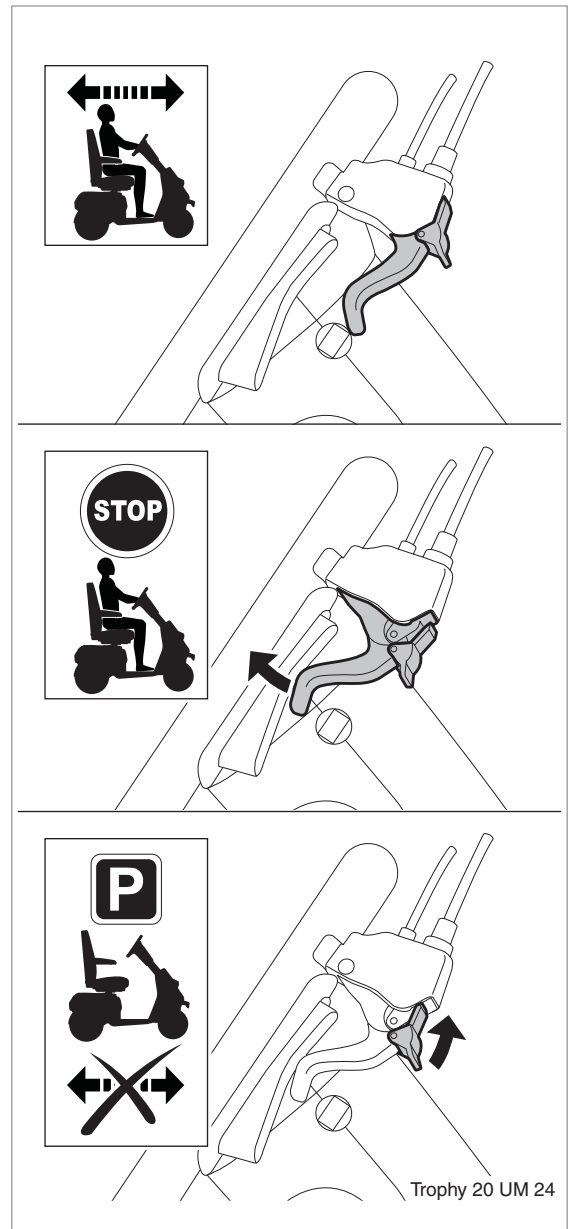

Figure 14

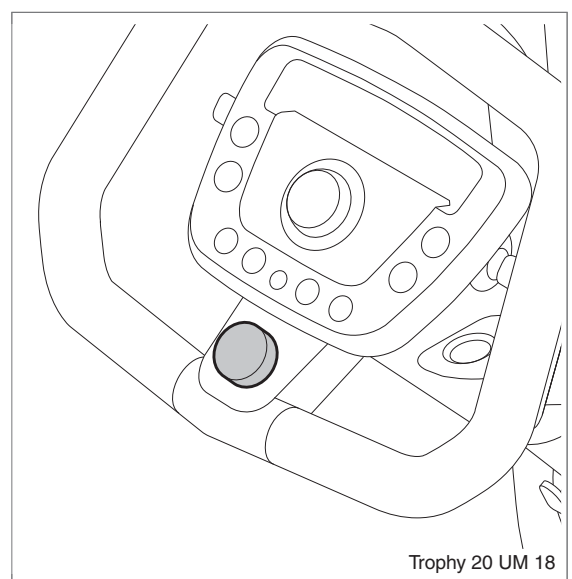

Figure 15

Limitations counts only when suspension is correctly adjusted according to weight specifications. Contact your dealer for adjustments.

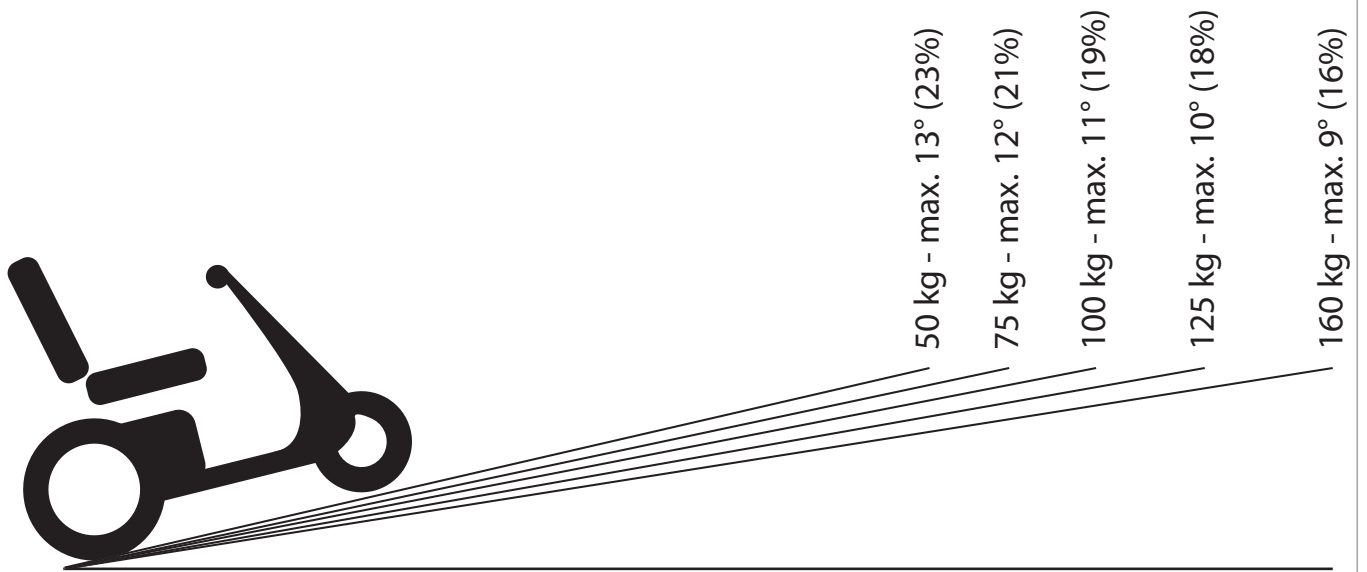

Figure 16 Standard version and Alpine version

## Slopes

- Although the Trophy 20 can bear a maximum weight of 160 kg, it is important that the following safety regulations be observed when driving up slopes.
- When driving up slopes you must adopt a specific body position which increases stability. This is achieved by leaning your upper body forwards. This renders the scooter more stable. The position for improved stability is illustrated opposite. In addition, the scooter's backrest should never be inclined too far back and the seat must be pushed forward.
- Driving up slopes with gradients greater than those given in the following table is not permitted.

---

### **Warning!**

*Observe these regulations. Not doing so may lead to scooter instability and to the scooter tipping over, which may result in personal injury and/or damage to your scooter.*

---

## Instructions for driving up slopes

- Adopt the position for improved stability by leaning your upper body forwards. This renders your scooter more stable. Your position can be further improved by sliding the seat further forward.
- Drive up slopes at half your normal speed.
- Maintain a constant speed while driving up slopes.
- Avoid sudden movements and jolts, such as sudden braking or accelerating.
- Do not change direction and do not attempt to turn when driving up a slope.
- Slopes should be driven up at a perpendicular angle. Do not attempt to turn and/or to drive up the slope diagonally.
- Never attempt to drive up a slope when there are possible hazards, such as slopes covered in snow, black ice, mown grass or wet leaves.
- If you notice that the scooter's speed decreases significantly when mounting a slope, you are advised to select a route which is less steep. This is to avoid the danger of the motor overheating.
- Driving up a slope for too long can cause the

motor to overheat.

- In such cases the electronics are switched off in order to prevent motor failure.
- Remove the ignition key from the lock and allow the motor to cool down for a while.
- It is always advisable to select a less steep route wherever possible.

---

### **Warning!**

*Non-observance of these regulations may lead to scooter instability and to the scooter tipping over. This may result in personal injury and/or damage to your scooter.*

---

**Driving down slopes (figure 17)**

When driving down slopes, drive as slowly as possible and with the utmost control.

**Warning!**

Turn the speed regulator fully to the left (to the lowest speed) before driving down a slope.

Lean your upper body to the rear and, when braking, brake gently. Braking too hard can cause the scooter to tip forwards.

**Obstacles (figure 18)**

Driving over obstacles

- Drive straight towards the kerb or other obstacle and stop when the front wheel is almost touching the obstacle.
- Then press the drive lever and drive onto the pavement without changing direction.
- Once the front wheel is on the pavement, the same speed must be maintained so that the rear wheels can also mount the pavement.
- If it is not possible to drive onto the pavement, look for a location where the kerb is lower.
- Obstacles must always be approached at right angles (figure 19).
- It is always advisable to make use of kerbs lowered for vehicles rather than driving over high kerbs.
- Do not drive over obstacles which are higher than 5 cm.

**Warning!**

Practise by driving over low obstacles, slowly increasing heights until you are able to drive over obstacles of the maximum height. Allow yourself plenty of time for this..

**Descending from obstacles**

- Exercise extreme caution when descending from obstacles.
- Drive straight towards the kerb and stop at the kerb's edge.
- Carefully press the drive lever and allow the scooter to drive off of the pavement without changing direction.

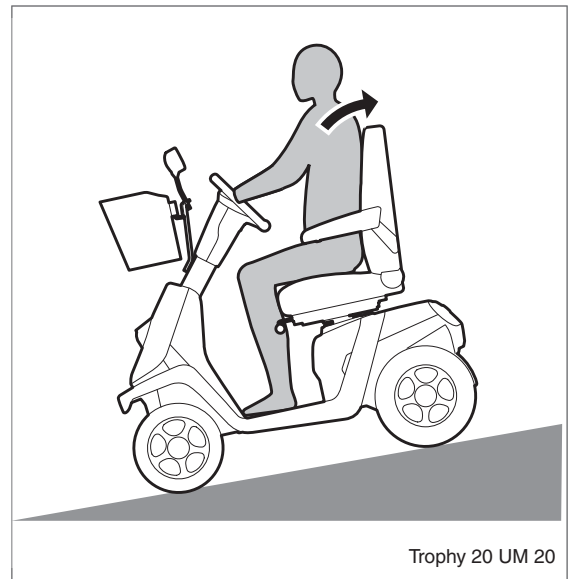

Trophy 20 UM 20

Figure 17

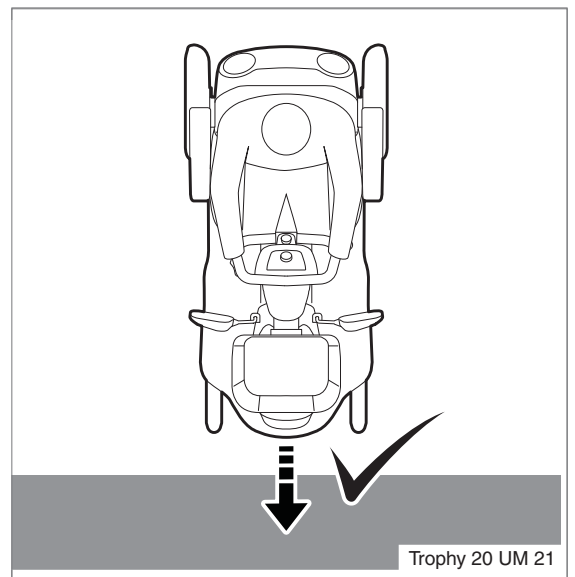

Trophy 20 UM 21

Figure 18

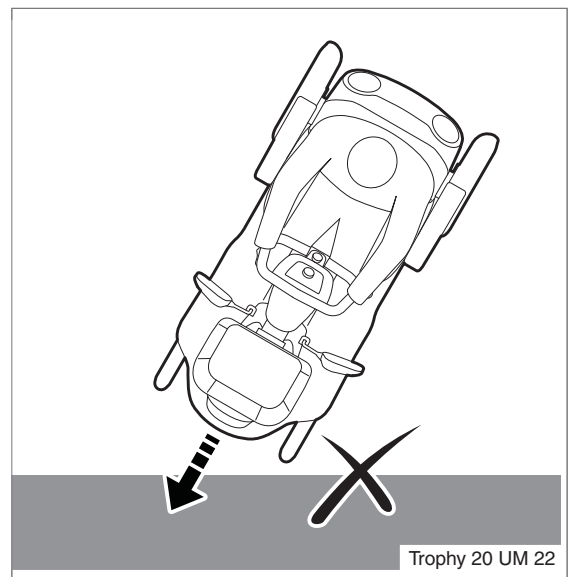

Trophy 20 UM 22

Figure 19

**⚠ Warning!**

*Driving down stairs or steps is not permitted. Doing so is extremely dangerous. The scooter is equipped with anti-tip wheels offering extra stability and safety. These small wheels may hit an obstacle as you are descending from it.*

*Ensure that the rear wheels of the scooter are at equal height at all times. The scooter may become unstable if they are not.*

---

**Automatic cut-out on overload**

- Remove the ignition key from the lock and allow the motor to cool down.
- Incorrect use may also cause unnecessary defects and damage to the scooter.

**Switching off**

The scooter should be switched off completely after every drive. This prevents the batteries from running down unnecessarily and having to be recharged.

---

**⚠ Warning!**

*Always remove the ignition key from the lock when not driving the scooter, even if you are planning to stay seated on the scooter while it is parked. This prevents you from accidentally setting the scooter in motion by inadvertently touching the drive lever.*

---

**Parking**

Having parked, remove the ignition key from the lock so that it is not possible for anyone else to use your Trophy 20 without your permission. Once the scooter has been turned off (the ignition key has been removed from the lock), the scooter's parking brake remains applied, even if the batteries are removed. If the scooter is put into freewheel / neutral mode, the scooter's automatic parking brake is NOT applied!

**⚠ Warning!**

*If the scooter is brought to a standstill on a slope, then the automatic parking brake must be applied. For this reason never put the freewheel handle in freewheel / neutral mode when on a slope.*

---

## 5.6 Pushing the scooter

In the event of a defect, or if the battery capacity is too low for driving the scooter, the scooter can also be pushed by hand. Pushing the scooter can be useful when parking or when manoeuvring the scooter into a small space for storage.

- Turn the scooter off by removing the ignition key from the lock.
  - Put the freewheel handle in the freewheel / neutral mode.
- 

**⚠ Warning!**

*Make sure before doing this, that nobody is seated on the scooter*

---

If the scooter is pushed too quickly, a built-in safety mechanism applies the brakes, causing the scooter to slow down.

### The scooter in freewheel / neutral mode (figure 20)

In order to enable the Trophy 20 to be pushed, the automatic parking brake must be disengaged as follows:

- Push the freewheel handle, which is located on the right-hand side of the motor cover at the rear, into the freewheel / neutral mode (B). This disengages the automatic parking brake. The Trophy 20's automatic parking brake can be re-applied by placing the freewheel handle back into the drive mode (A).

### Precautionary measures in freewheel / neutral mode

The scooter is equipped with a unique safety feature which prevents the scooter from rolling too quickly when in freewheel / neutral mode. If the scooter starts rolling when in freewheel / neutral mode, the motor brake automatically brakes the scooter until it comes to a standstill.

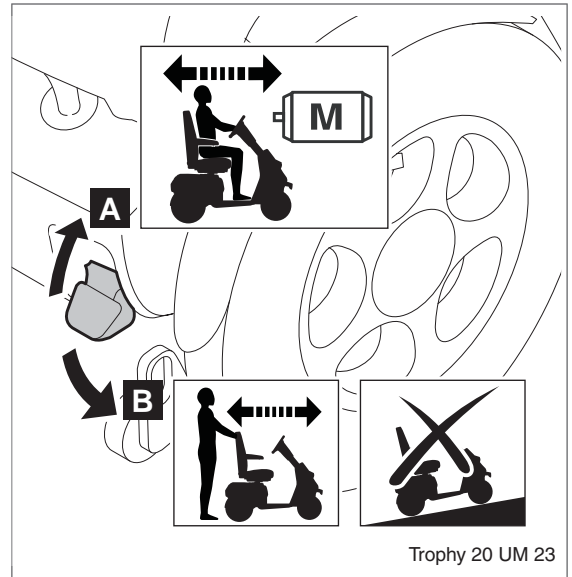

Figure 20

### ⚠ Warning!

Ensure that the freewheel handle is in the drive mode before being seated on the scooter.

Never sit on the scooter when the scooter is in freewheel / neutral mode.

NEVER touch the freewheel handle while driving.

Do not touch the drive lever / throttle while operating the freewheel handle.

The freewheel handle is only to be used when the scooter needs to be pushed. By putting the scooter in freewheel / neutral mode, the motor is mechanically disengaged, as a result of which the automatic parking brake no longer works. For this reason it is important for the handle to be put back into the drive mode immediately after pushing the scooter, so that the automatic parking brake is re-engaged.

NEVER put the scooter in freewheel / neutral mode when parked on a slope. The scooter will then roll down the slope due to gravity.

Always use the additional manual parking brake when the scooter is in freewheel / neutral mode.

When the Trophy 20 is in freewheel / neutral mode:

- It is not possible to drive the scooter.
- The electronics can be turned on, but the motor cannot drive the scooter.

For this reason the electronics should be switched off in such situations.

The following steps need to be taken in order to be able to drive the Trophy 20 again:

- Put the freewheel handle in the drive mode.
- Turn the scooter on by inserting the ignition key in the lock.

## 5.7 Dismantling the scooter for storage and/or transportation

The Trophy 20 can be dismantled so that it can be stored in a small space or transported in a small car. The scooter takes up less room in its dismantled state. Take the following steps in order to dismantle your Trophy 20.

### Removing the seat (figure 21)

(seat may vary slightly from the illustration)

The seat is removed as follows:

- Push the release lever forward to release the seat's swivel mechanism.
- Lift the seat off of the seat post.
- The seat can be easily lifted by swivelling it slightly while lifting.
- The size of the seat is reduced by folding the backrest fully forwards, making it easier to lift the seat off of the seat post.

### Collapsing the steering column (figure 22 and 23)

The steering column can be collapsed as follows:

- Pull handle (A) downwards, at the same time pulling the steering column downwards.

### **Warning!**

*Exercise caution when collapsing the steering column; ensure that your fingers do not become trapped.*

### Lifting and loading

- We recommend that you always get someone to help you to load the dismantled scooter into a vehicle.
- When loading the dismantled scooter into a car, ensure that the freewheel handle to the rear of the scooter has been set to the drive mode.



Figure 21

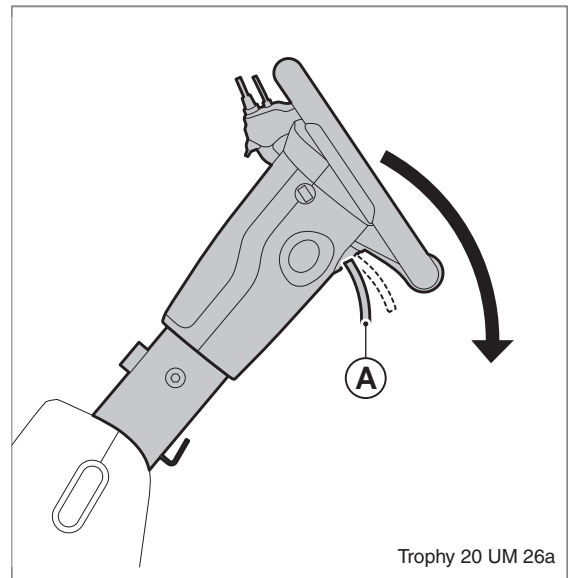

Figure 22

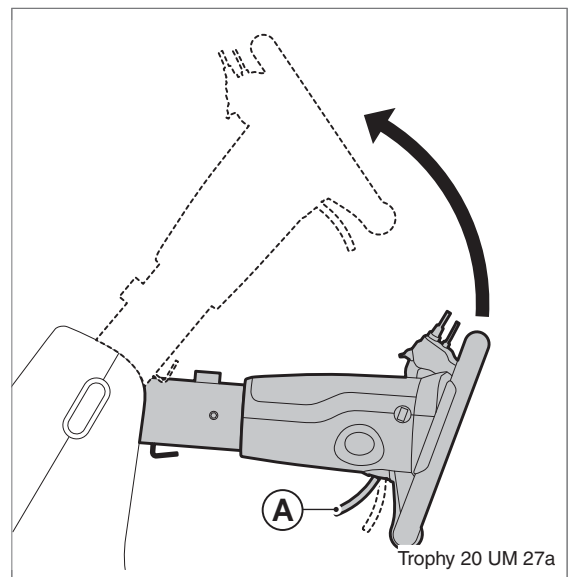

Figure 23

- Once the scooter has been loaded, check if the batteries are fixed with their belts.
- You are responsible for ensuring that all of the components of the dismantled scooter are secured in the car and that they will pose no hazard in the event of a collision.

## 5.8 Transporting the scooter

The following guidelines should be observed when transporting the Trophy 20 in its fully assembled state by car suitable for this purpose:

### **Warning!**

*If the scooter is to be lifted into the car, never lift the scooter by its plastic covers and do not attempt to lift the scooter on your own. If your scooter fits into a car in a fully assembled state, do NOT use the scooter as a passenger seat in the car. You must be seated in a normal car seat, even if the car in question has been adapted for the transportation of scooters. The reason for this is that the Trophy 20 can not offer the same level of safety as a normal car seat, irrespective of how well the scooter is secured in the car.*

*Having positioned the scooter in the car, you must check that the scooter is not in freewheel / neutral mode.*

The scooter features securement points on the rear and underneath (at the front of the platform, see figure 24). The securement points are exclusively designed for facilitating securement. We would like to point out that any dismantled scooter components which are not secured in a vehicle may cause damage if the vehicle should make any abrupt movements.

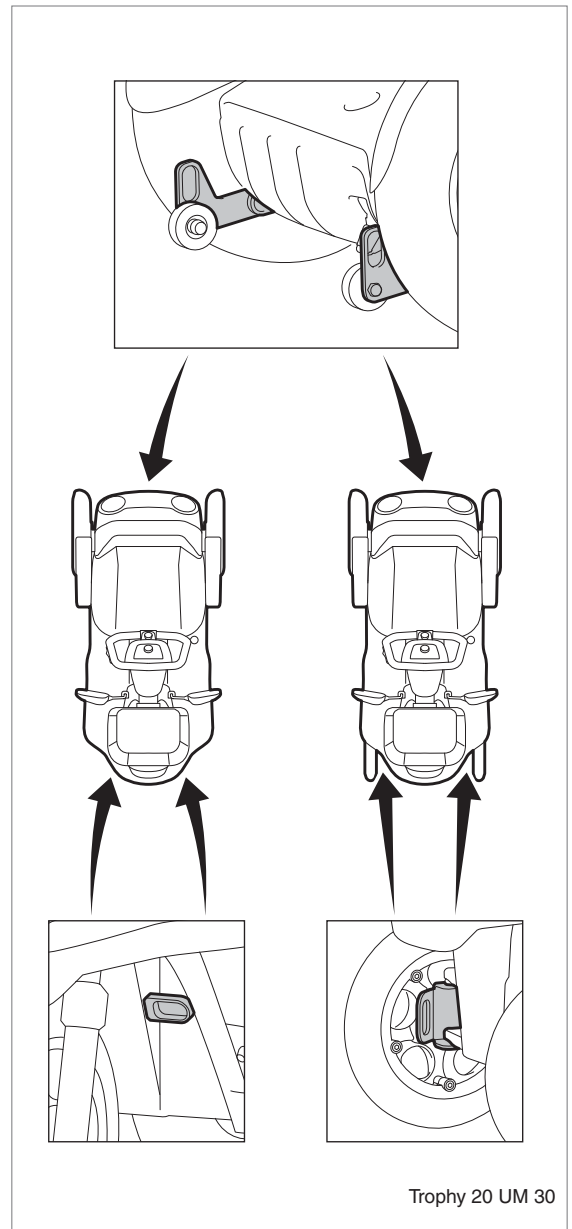

Figure 24

## 5.9 Storage after use

When the scooter is not in use, it must be stored in a dry place where it will not be exposed to weather conditions.

- Fully charge the batteries
- Detach battery cables (figure 25), or regularly charge the batteries
- Clean and dry the scooter (see 6.3)
- Ensure tyres are at the correct pressure (see 6.2)

---

### **Note!**

*Do not place the scooter in direct sunlight. Under such circumstances, parts of the scooter can become so hot that they cause burns. During storage, the ambient temperature should not be lower than  $-20^{\circ}\text{C}$  or higher than  $+65^{\circ}\text{C}$ .*

---

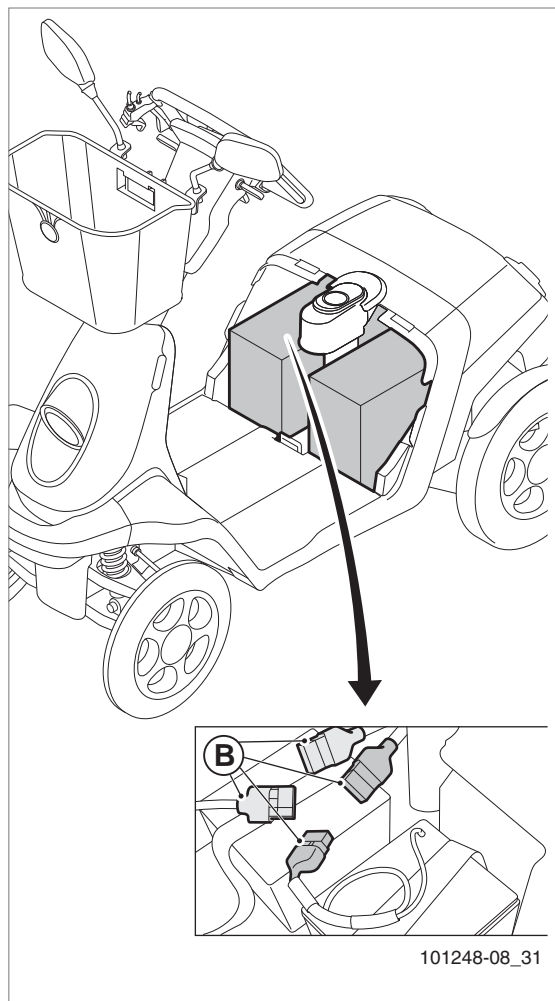

Figure 25

## 6 Maintenance

### 6.1 Maintenance table

In order to ensure its best performance, durability and lifespan, your scooter should undergo regular maintenance to be carried out by your dealer.

The following table indicates what checks should be made, how often these checks should be made and who should make them.

Frequency	Description	User
Daily	Recharge batteries after each full day of use	X
Weekly	Check tyre pressure	X
	Check for oil leaks under scooter	X
Monthly	Clean scooter (see cleaning procedures)	X
	Clean upholstery (if required)	X
Every three months	Grease the seat's swivel mechanism: the seat needs to be removed for this. See 'Removing the seat'. Lithium grease is recommended	X

The maintenance that you will be able to carry out yourself is indicated in the above table. It is recommended that your dealer carries out a service inspection on your scooter at least once a year. See inspection record chapter 10. If the scooter is used intensively, the service should be carried out every six months. In principle, we recommend that you allow your dealer to carry out all required maintenance on your scooter.

#### **Warning**

*If you should find traces of oil underneath your scooter, you should immediately notify your dealer of this. In such cases do not drive your scooter.*

### 6.2 Batteries

Consult the following documentation on battery maintenance:

- Current regulations relating to batteries
- The user manual for the battery charger or the instructions on the battery charger ( Battery charger)

The scooter is equipped with gel batteries. These batteries are fully encased and sealed and require no maintenance. A sticker indicates how the batteries are to be connected. This sticker is located on the inside of the battery compartment cover.

#### **Warning!**

*Ensure that the batteries are always well charged.*

*Do not use the scooter if the batteries are almost flat. Doing so may damage the batteries and means you run the risk of coming to an unexpected standstill.*

*Ensure that the batteries are never completely flat. This can seriously damage the batteries and shorten their lifespan.*

*The use of 'wet' batteries is not permitted. If the batteries need to be replaced, then gel batteries must be used.*

---

### Replacing the batteries

If battery capacity is so low that the scooter can only make short trips, or can not be driven at all, then the batteries have reached the end of their lifespan. Replace the batteries as soon as possible.

---

#### **Warning!**

*Contact your dealer: your dealer will know exactly which batteries are most suitable for your scooter and how to replace the batteries.*

---

Once the new batteries have been put in place they will need to be charged and 'run in' See 5.1 'Charging the batteries'.

See 6.5 'Used scooters and the environment' for the correct way to dispose of batteries.

### Cleaning the batteries

Gel batteries are maintenance-free. However, attention may be paid to the following matters:

- Ensure that the batteries remain clean and dry: dirt and water can cause leaks, as a result of which battery capacity can be reduced.
- Clean the battery terminals and then grease them using acid-free Vaseline.

## 6.3 Tyres

To ensure that your scooter performs well, it is of great importance for the tyres to be kept at the right pressure.

### Inflating the tyres

The tyres are equipped with a car tyre valve. You can have the tyres inflated by your dealer, or at your local petrol station. You can also inflate the tyres yourself using a hand or foot pump. Remove the caps from the valves before inflating the tyres. If the tyres are not adequately inflated, the range of the scooter may be reduced and the tread may wear more quickly. See the 'product specifications' for the correct tyre pressure.

#### **Warning!**

*When inflating tyres, never exceed the maximum recommended tyre pressure which is stated on the tyres (2.5 bar front and 3.5 bar rear).*

*Never forget to replace the valve cap after inflating the tyres. The valve cap prevents dirt and sand from getting into the valve.*

---

See the 'Maintenance table' regarding tyre checks.

Contact your dealer to repair tyre punctures.

## 6.4 Cleaning the scooter

### Removing dry dirt

The upholstery, metal parts and frame components can usually be cleaned with ease using a soft, dry cloth.

### Removing mud and/or other wet dirt

Components which have become dirty due to wet dirt are best removed by first cleaning with a damp cloth and then with a soft, dry cloth.

### Upholstery

Cleaning with a damp cloth. Once the dirt has been removed, the parts which have been cleaned need to be dried using a soft, dry cloth.

#### **Warning!**

*Never use caustic cleaning products. These can be damaging to the scooter. Do not use organic solvents, such as thinners, chemical-cleaning naphtha or methylated spirits.*

*Do not spray or pour water onto your scooter.*

*Exercise caution when using water near to the electronic system.*

*Upholstery: do not chemically clean, iron or spin-dry.*

---

## 6.5 Used scooters and the environment

Under normal use and with prescribed maintenance, the scooter's expected lifespan is approximately seven years.



If your scooter is no longer required or needs to be replaced, it will usually be possible to arrange for your dealer to take it back. If this should not be possible, consult with your local authority to find out if the scooter can be recycled or if the materials used in it can be processed in an environmentally friendly way.

Various plastics and metals were used in the manufacture of the scooter. The scooter also contains electronic components which should be disposed of accordingly. The batteries constitute chemical waste

## 7 Troubleshooting

If your Trophy 20 is not working even though the batteries are fully charged, the following checks can be carried out before contacting your dealer.

1. Check whether all of the battery clips are firmly in place.
2. Check whether the freewheel handle is in the drive mode (and not in the freewheel / neutral mode).

### 7.1 Troubleshooting table

If your scooter is not working, or is not working as it should, go through the following list of possible problems before contacting your dealer. You may be able to solve the problem yourself.

Problem	Possible cause	Action	Action to be taken by:
Scooter cannot be switched 'on'	The battery clips are not properly attached.	Check the battery clips.	User
Scooter 'on' cannot drive	The connector cables in the motor compartment are not properly connected to the control mechanism, or are loose.	Check the connector cables and ensure that they are properly connected to the control mechanism.	Dealer
	The scooter is in freewheel / neutral mode.	Move the freewheel handle to the drive mode and remove the ignition key from the lock. Reinsert the ignition key to restart the scooter.	User
	The manual brake is active	Release the manual brake	User
	The emergency stop button is activated	De-activate the emergency stop button	User
Scooter drives very slowly	The battery voltage is too low.	<ul style="list-style-type: none"> <li>• Check the battery voltage. See 'Battery indicator'</li> <li>• Recharge the batteries for eight hours.</li> <li>• Check whether the battery charger is working properly</li> </ul>	
	Speed selector switch is in slow (most left) position	Turn the speed regulator knob to the right.	User
	The motor has overheated.	Remove the ignition key from the lock and allow the scooter to cool down.	User

Problems can sometimes be solved by turning the scooter off and then turning it back on again.

If you are not able to solve a problem by consulting the above list, then you should contact your dealer.

## 8 Technical specifications

### 8.1 CE declaration



The product complies with the regulations of the Medical Devices Directive and therefore bears the CE mark.

#### Approvals

The product meets the following requirements:

- EN12184; 2009 Electrically powered wheelchairs and scooters, class B.
- ISO7176-8 Requirements for static, impact and fatigue strengths.
- ISO7176-9 Climatic tests for electric wheelchairs and scooters.
- ISO7176-14 Requirements and test methods for power and control systems for electric wheelchairs.
- ISO7176-16 Requirements for resistance to ignition of upholstered parts.

The product has been EMC-approved (for electromagnetic compatibility) in accordance with EN12184. (2009)

### 8.2 Trophy 20 product specifications

<b>Model</b>	Trophy 20 3 wheels (3W) Trophy 20 4 wheels (4W)		
<b>Maximum user weight</b>	160 kg (25.2 stone)		
<b>Description</b>		<b>3W</b>	<b>4W</b>
Total length	mm (inches)	1265 (49.8)	1265 (49.8)
Total width	mm (inches)	660 (26)	660 (26)
Minimum height*	mm (inches)	740 (29.1)*	740 (29.1)*
Total weight excluding batteries	kg (stone)	92 (14.5)	102 (16.1)
Total weight including batteries (74 Ah C20)	kg (stone)	140 (22)	150 (23.6)
Weight of heaviest component	kg (stone)	70 (11)	80 (12.6)
Static stability in the downward direction	°	> 13	> 13
Static stability in the upward direction	°	> 13	> 13
Lateral static stability	°	> 13	> 13
Distance range (ISO 7176-4)**	km (miles)	45 (28)	45 (28)
Dynamic stability (max. safe slope)	°	9	9
Maximum speed forwards	km/h (mph)	6 / 12 (3.7 / 7.5)	6 / 12 (3.7 / 7.5)
Back angle, Captain Seat	°	0 / 103 / 126	0 / 103 / 126
Seat depth, Captain Seat	mm (inches)	445 (17.5)	445 (17.5)
Seat width, Captain Seat	mm (inches)	457 (18)	457 (18)
Back height (excl. headrest), Captain Seat	mm (inches)	406 (16)	406 (16)
Seat height (to platform), Captain Seat***	mm (inches)	350 / 450 / 535 (13.8/17.7/21.1)	350 / 450 / 535 (13.8/17.7/21.1)
Armrest height, Captain Seat	mm (inches)	229 / 273 (9 / 10.7)	229 / 273 (9 / 10.7)

Description		3W	4W
Distance between armrests, Captain Seat	mm (inches)	457 - 610 (18 - 24)	457 - 610 (18 - 24)
Back angle, Master Seat	°	45 / 85 / 180	45 / 85 / 180
Seat depth, Master Seat	mm (inches)	430 (17)	430 (17)
Seat width, Master Seat	mm (inches)	500 (19.7)	500 (19.7)
Back height (excl. headrest), Master Seat	mm (inches)	550 (21.7)	550 (21.7)
Seat height (to platform), Master Seat***	mm (inches)	350 / 425 / 535 (13.8/16.7/21.1)	350 / 425 / 535 (13.8/16.7/21.1)
Armrest height, Master Seat	mm (inches)	150 / 340 (5.9 / 13.4)	150 / 340 (5.9 / 13.4)
Distance between armrests, Master Seat	mm (inches)	500 (19.7)	500 (19.7)
Turning radius (ISO 7176-5)	mm (inches)	1030 (40.6)	1600 (63)
Reversing width	mm (inches)	1460 (57.5)	1810 (71.3)
Obstacle height (max. user weight)	mm (inches)	80 (3.1)	80 (3.1)
Ground clearance (max. user weight / loaded)	mm (inches)	70 (2.8)	70 (2.8)

#### Test data

Test weight	160 kg
-------------	--------

#### Operating force

Drive lever operation	< 20 [N]
Resetting the automatic fuse (circuit breaker)	< 60 [N]
Electronic switches	< 13.5 [N]
Connecting the charger plug	< 60 [N]

#### Technical specifications for wheels

Front wheel diameter (3W)	mm (inches)	320 x 60 (12.6 x 2.4)
Front wheel diameter (4W)	mm (inches)	320 x 60 (12.6 x 2.4)
Rear wheel diameter	mm (inches)	360 x 80 (14.2 x 3.1)
Tyre pressure 4W, front wheel	bar (psi)	2,5 (36.3)
Tyre pressure 4W, rear wheel	bar (psi)	3,5 (50.8)
Tyre pressure 3W, front wheel	bar (psi)	2,5 (36.3)
Tyre pressure 3W, rear wheel	bar (psi)	3,5 (50.8)

#### Batteries

Maximum dimensions of batteries (lxbxh)	mm (inches)	262 x 173 x 211 (10.3 x 6.8 x 8.3)
Max. battery capacity C20	Ah	74
Max. battery capacity C5	Ah	63
Maximum permitted charging current	Ampère	8 RMS

\* height of steering column, collapsed, excluding seat

\*\* range dependent on user weight, condition of tyres, type of terrain, condition of battery and weather conditions with 74 Ah (C20)

\*\*\* Seat height < 450 mm (Captain Seat) and < 425 mm (Master Seat) requires an elevated footplate.

## 9 Warranty

### 9.1 Provisions of warranty

In the warranty and liability provisions the following terms are defined as follows:

- **Product:** The manual or electric wheelchair or scooter manufactured and supplied by Handicare.
- **Customer:** The person who directly obtains a product from Handicare.
- **Dealer:** The person who supplies a product obtained from Handicare to third parties.
- **User:** The person who uses a product manufactured by Handicare.

Irrespective of what has been determined concerning warranty conditions in the general terms and conditions applicable to the product, the following shall in any case apply with regard to the warranty:

1. Except insofar as described otherwise in the provisions below, Handicare guarantees the product for its suitability for the purpose for which the product is intended - all of these points as described in this manual - and for the quality of the material of which the product is made and the manner in which the product is manufactured.
2. Repairs or replacement of parts of the product that may be necessary as a result of faults that are based on qualitatively faulty material or manufacturing errors shall be carried out free of charge, as long as such faults occurred within one (1) year of the date of delivery of the product to the Customer. The parts to be replaced must be shipped post-paid to Handicare. Disassembly or assembly of these parts shall be at the expense of the Customer. Therefore the following cases shall not be eligible for free repair or replacement as referred to in the previous sentence:
  - A. Repair or replacement that is necessary in connection with faults that arise after one (1) year from the date of delivery of the product to the Customer;
  - B. Repair or replacement that is required in connection with faults due to improper or careless use of the product or that are based on the product being used for another purpose than the one for which it is intended, in which regard it shall apply that if the Customer is a Dealer, this Dealer shall indemnify Handicare against possible claims from Users or other third parties for faults based on an incorrect or careless use of the product;
  - C. Parts that are subject to wear, and the need for repair or replacement of the parts is the actual consequence of normal wear.
3. Irrespective of that stipulated under 2, as far as an electric product is concerned it shall apply that, with regard to the battery that forms part of the product, warranty is only given in case of faults or non-functioning of the battery that are demonstrably the direct consequence of material or manufacturing errors. A fault or non-functioning of the battery as a result of normal wear is not covered by the warranty as referred to in these warranty provisions. Similarly not covered by the warranty are faults or non-functioning that are the consequence of improper or unprofessional use of the product or the battery that is part of the product, including the incorrect charging of the battery and the failure to carry out timely and proper maintenance, in which context it shall also apply that if the Customer is a Dealer, this Dealer shall indemnify Handicare against possible claims from Users or other third parties that are based on the above-mentioned improper or unprofessional use of the product or the battery that is part of the product.
4. The warranty conditions as stated in the above provisions shall in any case become null and void if:
  - A. Handicare's guidelines for the maintenance of the product have not, or have insufficiently, been followed;
  - B. A necessary repair or replacement of parts is based on neglect, damage or abuse of the product or a use of the product for another purpose than the one for which it was intended;
  - C. Parts of the product have been replaced by parts of another origin than those which Handicare uses and/or parts of the product have been replaced without the permission of Handicare.

5. The warranties as stated in provisions 1 to 3 also become null and void in the case of re-use by a new user within the warranty period and when such re-use necessitates adaptations to the product and those adaptations were not carried out on the instructions of and/or at the order of Handicare.
6. To retain rights under the above delineated warranties, the Customer must, in the case of damage or other calamities, contact Handicare as quickly as possible and provide Handicare with as much information as possible. The possibility of taking recourse to the above-mentioned warranty conditions shall in any case become null and void for the Customer after 20 workdays following the date of the claim incident or the calamity forming the basis for recourse to the guarantee.
7. The replacement of a part or the repair or the reconditioning of the product within the period a warranty period shall not extend the warranty period.
8. Handicare gives no warranty on repair to or reconditioning of the product carried out other than under order of and/or on the instructions of Handicare. If repairs and/or reconditioning are carried out by or on behalf of a Customer, the Customer shall indemnify Handicare with respect to claims made by third parties which, in the broadest sense of the word, result from such repairs or reconditioning.

## 9.2 Liability provisions

Irrespective of what is determined regarding liability in the general terms and conditions applicable to the product, the following shall in any case apply with regard to liability:

1. Taking into consideration the following provisions, Handicare shall only accept liability for loss due to death or physical injury that is the result of a defect in the product for which Handicare is responsible and for damage to another object that is the private property of the user of the product, as long as said loss is the direct result of a fault in the product.
2. Handicare accepts no other or further liability than delineated under 1. In particular Handicare accepts no liability for consequential damage, in any form whatsoever.

## 10 Maintenance and inspection record

For the guarantee on your scooter to apply in full, it must be maintained on a regular basis. Ensure that each inspection is recorded in the tables below.

	Annual inspection						
	1	2	3	4	5	6	7
<b>Electronics</b>							
On / off switch							
Output connector							
Operation							
Brake							
Programmable settings							
<b>Batteries</b>							
Level							
Connections							
Capacity test							
<b>Wheels and tyres</b>							
Tread depth							
Pressure							
Bearings							
Wheel fixing nuts							
<b>Motors</b>							
Cables							
Noise							
Connections							
Brake							
Brushes							
<b>Chassis</b>							
Condition							
Steering							
<b>Seating</b>							
Seat							
Backrest							
Armrests							
<b>Electrical</b>							
Harnesses							
Connections							
Lighting system							
<b>Test</b>							
Forwards							
Backwards							

	Annual inspection						
	1	2	3	4	5	6	7
Emergency stop							
Left turn							
Right turn							
Uphill / downhill							
Obstacle							
Brake							
<b>List of necessary repairs:</b>							

<b>Handover inspection</b>	<b>1st Annual inspection 2000 km</b>
Dealer stamp / date / signature	Dealer stamp / date / signature
<b>2nd Annual inspection 4000 km</b>	<b>3rd Annual inspection 6000 km</b>
Dealer stamp / date / signature	Dealer stamp / date / signature
<b>4th Annual inspection 8000 km</b>	<b>5th Annual inspection 10000 km</b>
Dealer stamp / date / signature	Dealer stamp / date / signature
<b>6th Annual inspection 12000 km</b>	
Dealer stamp / date / signature	Dealer stamp / date / signature

## 11 Authorised service and technical support

In the event of problems or questions relating to this product, please contact your dealer. Handicare can be contacted for information regarding dealers in your area:

Handicare	Handicare B.V. Vossenbeemd 104 5705 CL, Helmond Netherlands
-----------	--

<p>Dealer stamp</p>
---------------------

Dealer:

Serial number:



**handicare**

Handicare B.V.  
Vossenbeemd 104  
5705 CL Helmond  
The Netherlands

T +31 (0)492 593 888  
F +31 (0)492 537 931  
[www.handicare.com](http://www.handicare.com)